

The Journal of Engineering Drawing

CONTENTS

	Page
OPPORTUNITIES AND RESPONSIBILITIES OF GRAPHICS IN AN ENGINEERING EDUCATIONAL PROGRAM, by John T. Rule, Massachusetts Institute of Technology.	7
PROBLEM BOOKS - YES OR NO, by Irwin Wladaver and Lewis O. Johnson, New York University.	11
DRAWING COMPETITION.	12
PERSONALITY SKETCH OF PROFESSOR RALPH S. PAFFENBARGER, by Paul E. Machovina, Ohio State University.	13
AN INDEX TO THE PAST AND TO THE FUTURE, by Irwin Wladaver, New York University.	14
ACCURATE REPRESENTATION OF CIRCLES IN PICTORIAL DRAWINGS, by Professor S. B. Elrod, Purdue University	15
THE UNIVERSITY OF FLORIDA WELCOMES YOU	19
SIMPLIFIED CALCULATIONS FOR SPACE PROBLEMS, by Robert M. Johnston, California State Polytechnic College	20
PROGRAM - ANNUAL MEETING OF THE A.S.E.E.	24
REPORT OF THE BIBLIOGRAPHY COMMITTEE, by Professor H.H. Fenwick, University of Louisville	24
GEOMETRIC CONSTRUCTIONS, by F.E. Giesecke, Texas A and M College.	28
A WORD ABOUT UNIT TESTS IN ENGINEERING DRAWING.	29
FORMING TOOL CALCULATIONS - GRAPHICAL AND ALGEBRAIC, by Professor J. H. Porsch, Purdue University.	30
KNOW YOUR COMMITTEES, by Chairman J. Gerardi	35

CONTENTS

The Slide Rule
Reading the Scales
Construction of the Scales
Multiplication
Methods of Determining Decimal Point Location
Division
Combined Multiplication and Division
Squares and Square Roots
Cubes and Cube Roots
Trigonometric Functions
Mannheim Rule
Trigonometric Functions
Log-Log Rule
The Log-Log Scales
Right Triangle Solution
Log-Log Rule
Folded Scales
Reciprocal Scales

THE SLIDE RULE

by H. W. Leach and George C. Beakley

- *three dimensional diagrams*
- *examples and solved problems*
- *clear, simple presentation*

Coming in the Spring

This text, devoted exclusively to the study of the slide rule, includes progressively arranged instruction on the use of the slide rule, as well as a discussion of its practical value. The book features three dimensional diagrams, examples, and solved problems, to illustrate further the material.

The Macmillan Company

60 FIFTH AVENUE, NEW YORK 11



CUSTOM- MASTER

*Providing the Ultimate
in Selection and Variation*

BIG BOW - RULING PEN - DIVIDER

These key instruments provide 60 superb sets—many with provisions for additional instruments . . .

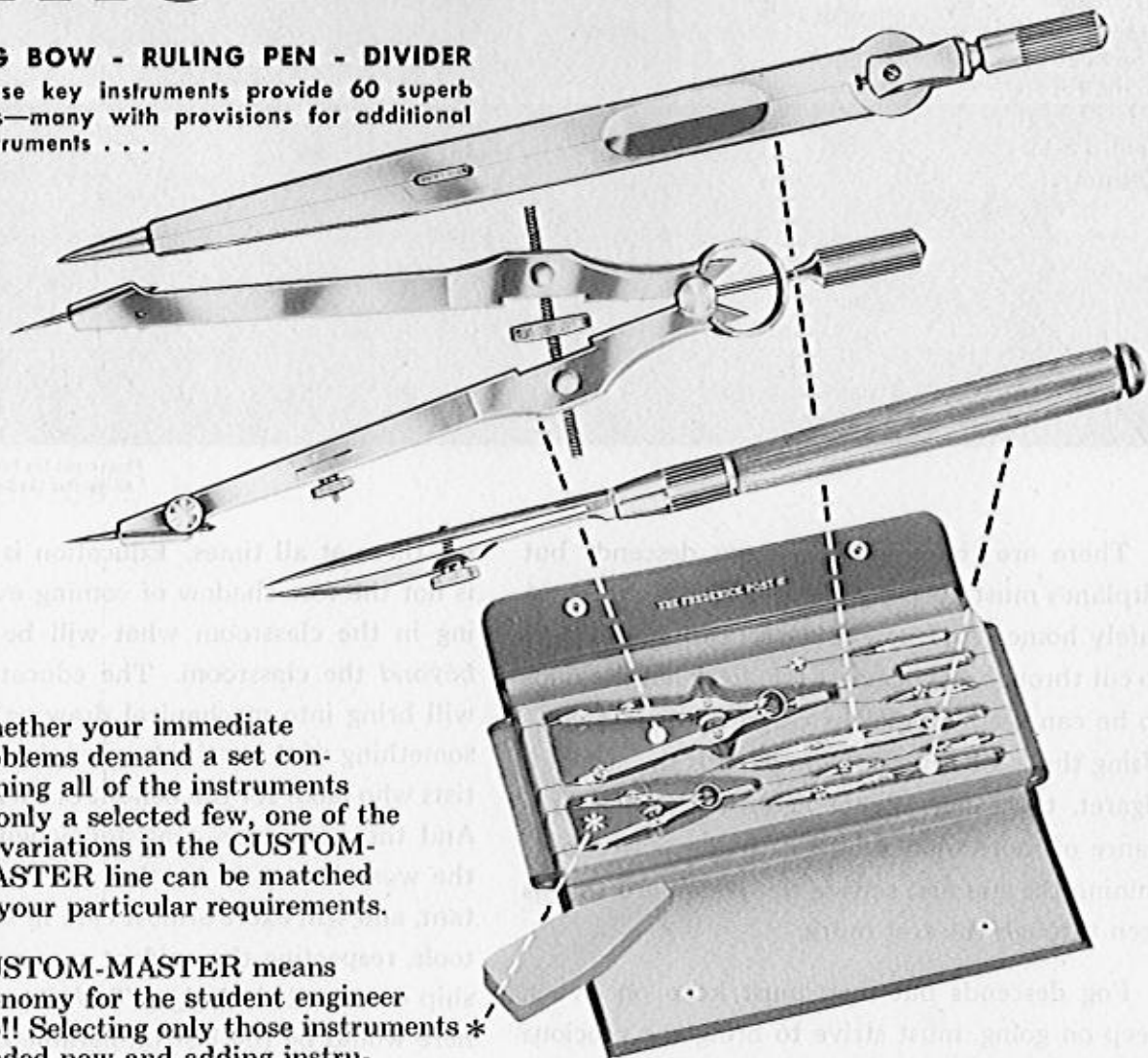

Whether your immediate problems demand a set containing all of the instruments or only a selected few, one of the 60 variations in the CUSTOM-MASTER line can be matched to your particular requirements.

CUSTOM-MASTER means economy for the student engineer too!! Selecting only those instruments * needed now and adding instruments as your requirements become more specialized, means a maximum of usefulness at a minimum of cost.

The precision and skilled craftsmanship that have characterized POST drawing instruments for nearly 60 years, guarantees the CUSTOM-MASTER user a lifetime of durable, accurate service.



Symbol of Quality

FREDERICK POST COMPANY

3650 N. Avondale Chicago 18, Illinois
DETROIT • ENGLEWOOD, N. J., • HOUSTON
LOS ANGELES • MILWAUKEE

Safely through the fog



Photo credit The Port of New York Authority
All Weather Landing Lights, N. Y. Airport

There are times when the fog descends but airplanes must keep on flying and strive to come safely home. And now science has found a way to cut through the heaviest fog, to signal the pilot so he can set his precious cargo down in safety. Using the gas Krypton in glass bulbs the size of a cigaret, these new signal lights develop a brilliance of more than 3 billion candle power, outshining the sun and setting up a standard that is seen through thickest murk.

Fog descends but men must keep on living, keep on going, must strive to bring the precious cargo of their lives safely home through the curving span of their years. Has the Krypton light that pierces the fog been developed in their case? Some say it is integrity of purpose, magnificence of effort, staunch opposition to the downward flow of things, which opposition may be life, may be spirit, may be the supreme creator. And the educator on whom the responsibility falls, must make sure these standards are clearly seen by the lads in his classroom, by possessing such standards himself, by unobtrusively living them and show-

ing them at all times. Education is nothing if it is not the fore-shadow of coming events, reflecting in the classroom what will be encountered *beyond* the classroom. The educator's integrity will bring into mechanical drawing for example, something of the attitude of engineers and scientists who labor for the benefit of their fellow men. And the educator's consistency will say that if the work is important, then its tools are important, and will exert utmost care in selecting these tools, respecting the evident care and craftsmanship used in their design. To *fail* to be consistent *here* would be the last intolerable cynicism.



EUGENE DIETZGEN CO.

CHICAGO
NEW YORK
SAN FRANCISCO
NEW ORLEANS
LOS ANGELES
PITTSBURGH
WASHINGTON
PHILADELPHIA
MILWAUKEE
Dealers in All Principal Cities

DIETZGEN

EVERYTHING FOR DRAFTING
SURVEYING & PRINT-MAKING

PROBLEMS
IN
ENGINEERING GRAPHICS
AND
DESCRIPTIVE GEOMETRY

J. H. PORSCH S. B. ELROD

Professors of Engineering Drawing
Purdue University

R. H. HAMMOND

Instructor of Graphics
United States Military Academy

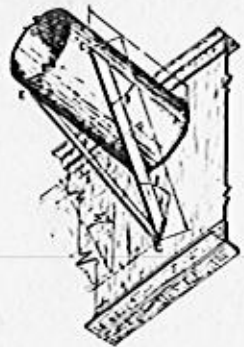
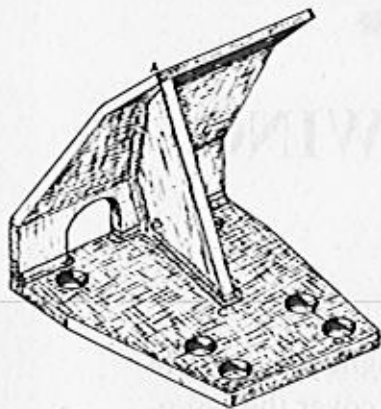

PROBLEM CLASSIFICATIONS

The figures listed below correspond to the figures preceding the dashes on the problem sheet numbers. They identify the phases of instruction related to the problems.

- 2 - Geometrical Elements
- 4 - Principal Views
- 5 - Auxiliary Views
- 6 - Intersections
- 7 - Traces of Lines
- 8 - Places in Trace Form
- 9 - Space Problems
- 10 - Curved Surfaces
- 12 - Conic Surface Loci
- 13 - Miscellaneous Applications

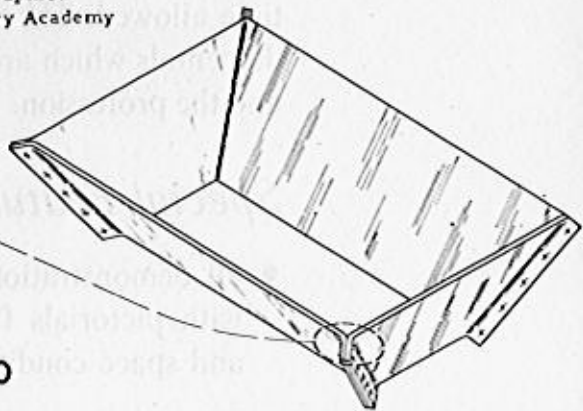

PRICE \$ 3.00

PROBLEMS IN ENGINEERING DRAWING-ABRIDGED
THIRD EDITION

By WARREN J. LUZADDER, J. N. ARNOLD and F. H. THOMPSON

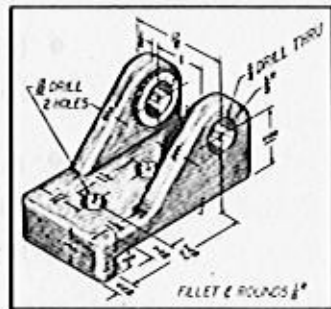
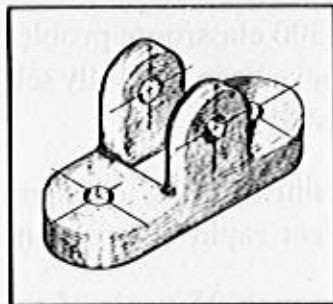
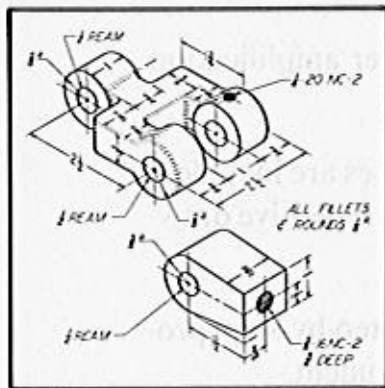

PRICE \$1.50

BALT PUBLISHERS

SOUTHWORTH'S EXTENSION SERVICE, SHIPPING AGENT
308 1/2 STATE STREET

WEST LAFAYETTE, INDIANA

TO BE READY IN SPRING 1953

ENGINEERING DRAWING

By FRANK ZOZZORA
University of Delaware

A concise, direct and teachable presentation designed to provide the teacher with a book which will enable him to cover the essential fundamentals of the subject in the customarily short space of time allowed. The student will acquire a firm grasp on the fundamentals which are basic to any drawing he may do in industry and the profession.

Special Features:

- all demonstration drawings and problems are supplemented with pictorials facilitating quick visualization of the object and space conditions involved.
- all complicated constructions and procedures are illustrated in a step-by-step manner.
- basic fundamentals are stressed, leaving further amplification for subsequent courses.
- more than 300 classroom problems and exercises are included. Problems have been carefully selected to avoid repetitive drawing by the student.
- the many illustrations, orthographics, and step-by-step procedures effect rapid comprehension by the student.

Developed through 25 years of teaching experience, this text is an exceptionally clear and graphic presentation of the fundamental techniques involved in engineering drawing.

SEND FOR A COPY ON APPROVAL

McGRAW-HILL BOOK COMPANY, Inc.

330 West 42nd Street New York 36, New York

OPPORTUNITIES AND RESPONSIBILITIES OF GRAPHICS IN AN ENGINEERING EDUCATIONAL PROGRAM

by

Professor John T. Rule

Massachusetts Institute of Technology

The philosophy of any form of education changes continually to meet new conditions and grows broader as our knowledge of its implications becomes clearer through the discipline of practice. The philosophy of each branch must change and grow with the trends of the whole or become isolated and atrophied.

The philosophy of engineering education has undergone striking changes as it has grown over the past century. Each part of it must be aware of the direction and meaning of this growth or that part will be sloughed off as a useless appendage. As it fails in such awareness it will decrease in importance, as it succeeds it will increase.

At the present moment many would like to have us believe that engineering drawing has failed to grow and is consequently undergoing the process of atrophy. The time allotted to drawing in our engineering schools is decreasing. Its contribution to engineering education seems to be lessening in importance. The problem we must solve is consequently very clear. Where do we seem to have remained static instead of having grown? What broader and more inclusive philosophy should we adopt to keep pace with that of engineering education?

In order to arrive at any legitimate conclusions we must first examine the history of such education and trace the growth of its dominant concepts in order that we may pattern ourselves thereto.

Perhaps it is safe to say that the first aim of engineering education was learning to do - the attaining of specific "know how" directly utilitarian in purpose and confined to a limited area. The emphasis was on the acquisition of the practical knowledge and skills useful in the particular area. A reasonable base of theory necessarily underlay the whole but the focus of attention was experience with the practical through the direct handling of materials. Put in a different way, the emphasis was on the end product.

Over the years there has been a gradual shift from learning how to do specific things to learning how to learn how. Acquiring the ability to solve new problems has become more important than acquiring valuable solutions to important problems. This has necessarily been so, for the quantity of desirable knowledge in any particular field has grown far beyond the capacity of any individual to acquire it in four years, - or, for that matter, in five. Hence we have gradually come to see that the processes of acquiring it, the methods of attack, are the really important factors. If we can impart, first, the ability to think creatively; second, the ability to continue to learn - that is, the ability to suspend judgment and continue to inquire, the ability to remain mentally dynamic; and third, the ability to make good judgments - then we have accomplished the most important things we can do.

Let's look at these in order.

First, we are coming to see that creative thinking hinges on the ability to make a wide range of free associations within the mind while analyzing any problem. Such associations spring up from the subconscious to the conscious during the problem examining process. The unsuccessful engineer - the nine-run pedestrian thinker - has certain standard, well-worn associative patterns which have proved successful with respect to limited, often-encountered problems. His mental associations never break through the boundaries of these standardized channels. This is the "crank-grinding" sort of mind which invariably tackles any problem in, let us say, physics or mathematics, by applying some known formula and plugging in the data. It is the over-simplified, black-and-white, opinionated mind that breaks down in the face of anything unusual and, which is much worse, in many instances reaches a usual solution which is secondary where an unusual, imaginative, first-rate solution exists.

Second, we are realizing that the direct acquisition of knowledge always faces the danger of stultifying the ability to continue to learn. Knowing the answers, or routine methods of obtaining answers, casts out doubt, and doubt is the motivating force of inquiry. Thus the inadequate answer or the wrong answer is never questioned, nor the possibilities for a better answer ever discovered.

The difficulty we encounter here is that thought processes cannot occur in a vacuum - that is, free associations cannot be made if you have no pieces of material to associate. Thus in all scientific areas we must provide the minimum of basic material on which the mind can operate. This means in physics, for instance, that we must supply the student with some of the basic concepts of physics and with enough "though practice" with them to get his mind to begin to operate in the frame of reference that is associated with successful thinking about physics. In doing this we quickly lose sight of our main objective and bring too much emphasis to bear on teaching the student too much about too many topics that seem on the surface to be of the utmost importance. Thus our courses are loaded with so-called "essential" material which has crowded out time for fruitful, imaginative thinking about any of it. The trend away from such teaching is evident in much of our educational literature in the repeated observation that we teach too many topics without enough depth, that we cover too much ground and thus lose the value that comes from contemplation of the process of attack after we have knowledge of any particular topic. Former President Doherty of the Carnegie Institute of Technology said that the undergraduate course in engineering should not train engineers but should train students to become engineers.

Third, there is a growing emphasis on good judgment as the one characteristic necessary to all engineers.

This naturally, demands that we attempt the development of the ability to make good judgments. Now judgment is a faculty which comes into play most strongly when only relative answers are possible, when information is incomplete, or over-abundant, when the number of variables is enormous and the question is not "What is the answer?" but "Which is the best answer?"

The attempt to teach the quality of judgment has led to the use of so-called "whole problems" through the devices of the project method and the case method. Design courses are another instrument in this area.

These methods help to cure our habit of invariably presenting theory first, giving beautiful demonstrations of how the physical world operates, developing mathematically the necessary equations and seeing to it that the student understands all this. We then have him do a number of problems which he solves by applying the theory and the formulae which we have fed him. This is not the best sort of thought producing process for it develops the "crank-grinding" tendency in the student. It is contrary to any form of real experience for it gives the student the results first and thus prevents him from coming in contact with the processes of reaching the results.

We are learning that a much more fruitful procedure is to immerse the student in bits of an unknown world and allow his mind to struggle to make the proper mental associations and the proper judgments, pulling him out of the morass when he goes too far wrong, and stimulating the proper associations by indirect suggestion in the middle of his struggle rather than always presenting them to him in a lecture prior to the problem.

Another variant with which we shall be more concerned later is the importance of the capacity to observe. No two individuals see or understand the same thing in the same way. They see different things both in quantity and in quality. The result is a function of their selective attention and their awareness. This is extremely important in dealing with people and in the area of design. The perception of form, color, balance, good design, and suggestive detail are all factors of awareness. Furthermore both the quantity and quality of what is observed can be improved by training. All Chinese look alike until you become acquainted with a number of them and then they all look as different as Americans. In all fields the trained eye or ear will detect subtle and important differences where the untrained sees only sameness. Nor is it out of place here to state that drawing in all its forms is a foremost instrument in sharpening and deepening the powers of perception.

I haven't mentioned the trend toward a broader education, the recognition of the importance of the humanities and the responsibilities of citizenship. These have quite rightly severely limited the time available for professional work.

Possibly we may sum up all I have said by saying that the growth of the philosophy of engineering education has lain along the road away from the directly utilitarian and practical, limited in purpose and scope, toward the higher concept that such education should be a form of general education producing a new form of truly educated men peculiarly fitted in breadth of understanding

and in capacity for competent action to guide the destinies of our complex modern world.

Perhaps we are now in a position to examine the effects of all this on our curricula in engineering and on our modes of teaching and thus narrow down to its effect on graphics.

The first surface thing we note is the decline in the teaching of skills. Foundry and shop are largely gone. Even the time devoted to laboratory has decreased somewhat. That devoted to drawing has decreased because drawing has been classed in the minds of many administrators as a skill. Certainly it is based on a skill. They also suspect that although it contains a high degree of immediately practical knowledge, it develops very little creative ability, or ability to continue to learn, or ability to make good judgments - in a word it does not develop intellectual power. They tend to forget its function of increasing the capacity to observe.

To all this we are in the habit of stating that "drawing is the language of the engineer" and therefore indispensable. This argument, though I believe it to be true, has gotten us substantially nowhere. I think the engineering philosopher answers it, at least in his own mind, by stating that the engineer needs to read and to speak the language but does not need to write it. To put this another way, he needs only to communicate with the man who has the skill in the written word - the draftsman - by means of the spoken word - the rough sketch. The draftsman can then employ the written word - the finished drawing - which the engineer need only then be able to read.

This is a very complex and difficult problem. We are more or less caught in a trap. All of us know that we cannot completely conform to the higher reaches of engineering philosophy. We all know that large numbers of our students are not going to be top flight engineers. We also know that they are going to be in need of a useful, money-earning skill to get them started toward the point where they will be in a position to use their more powerful weapons. We cannot and should not shirk the duty of producing reasonably competent draftsmen. Yet the very fact of the high practical content of our work somehow seems to obscure its deeper educational values. We must find means of fulfilling our practical mission and at the same time refute the contention that this is all we are doing. In other words, we must retain our utilitarian value, while more strongly highlighting its educational qualities, and at the same time move forward with the modern concepts of the meaning of engineering education.

But how? As yet we are only groping for the answers. We have started exploring in one direction with some of our graphics material. I hope to show that there are other avenues. The entire purpose of this paper is to examine, in the light of what I have said so far, the possibilities open to us.

I won't dwell long on the possibilities of graphics as a problem-solving tool. I've played that tune at great length over a number of years. It is true, however, that the theories of graphics have not been developed into a continuous logical structure. We have not

made it the geometric analog in all its processes of equational mathematics. I believe this can be done and that it will be a valuable branch of knowledge. Thus we have a relatively virgin scientific world - a highly exciting, stimulating, unexplored region capable of considerably more development than we have yet achieved. It offers us a major area for research that can stand on its own feet for its own sake. I certainly think that we should encourage our young men to work and publish in this area.

I do wish for a moment to relate this side of graphics to some of the tendencies in engineering education. First, I feel very strongly that it is one of the most fruitful areas for developing creative thought. I find no subject whatever in which original thinking is more a basic necessity than that of geometry. Graphical attacks on problems including those of descriptive geometry are very little susceptible to "crank-grinding" operations whereas equational mathematics, at the level that most of our students attain, very frequently is. The student in graphics has nothing in the way of formulae or standard procedures on which he can draw. He must be imaginative.

Second, the graphics "state of mind" is a powerful one and a much neglected one. For many physical problems the graphic or geometric mode of thought is much more illuminating and stimulating toward fruitful associations than is the equational. The aim of this phase of our work should be to develop in our students the instinctive tendency to look at all problems both ways so that they will think in terms of form and shape and space relations - that is, geometrically as well as in terms of algebraic symbols. Thus we have one area which we have already begun to develop.

Graphics also has its representational side. As a matter of fact, engineering drawing as we have always known it is pure representation aimed at describing the exact size and shape of objects. All drawing departments have been substantially limited to representing space objects within a rigidly standardized, industrially useful pattern. We all of course know that there is much to be gained from this. I think perhaps we would do well to emphasize somewhat more than we do its disciplinary qualities and its development of the ability to observe. Engineering drawing is the student's first professional course. It trains him in the capacity to take pains. It introduces him to the annoying minutia of details and of conforming to standards that are so basically necessary to all engineering practice.

At the moment, however, I am not interested in further discussing the virtues of our present work but in expanding our concept of the representational side of graphics. Dean Hollister tried to show us at Dartmouth that this representational aspect has the possibilities of much more than merely communicating the exact size and shape of useful objects, that it has within itself the capacity to develop visual awareness, to enable us to see the differences between Chinese, to develop an understanding of form and shape, of the feel for various materials and their possibilities, and of their aesthetic qualities. All of these are very subjective and involve subtlety of perception and imaginative visualization.

Of the factors in engineering education that I have

mentioned we are dealing here with those of creative imagination, good judgment, and above all, the capacity to observe coupled with the sense of good design. The latter is becoming ever more important to the engineer. Industrialists and those who have or assume responsibility for engineering education are becoming very conscious of its lack in our engineers and are turning their attention to means of developing it. Dean Hollister is but one of many. The importance he attaches to it is exemplified by the fact that he chose to point it out to us at a very busy time for him when he was also not in the best of health.

At the Massachusetts Institute of Technology at the moment, upon the request of the Departments of Architecture and of Mechanical Engineering, the Section of Graphics has been asked to prepare an exploratory nine-hour per week course for a full year to be required in certain areas in place of our current six hour courses in engineering drawing and descriptive geometry. As you will see, the latter are not to be left out but are to be used as tools in the development of the ability to observe and of the sense of form and design. I can do no better at this time than to quote portions of the statement of the purpose of the course so far as we have as yet developed the idea. The course is to be called "Fundamentals of Vision."

"Proposed herewith is a new presentation of first-year subjects in Graphics, oriented toward communication of form through graphic means, and intended for all students who wish to learn the fundamentals of the language of representational drawing.

"This proposal is made in the belief that drawing is as important to its sphere of ideas as words, mathematical symbols, and musical notation are to theirs. The visualization and communication of form are basic in the design of civic patterns, building, engineering structures, and integrated engineering assemblies such as transportation units and other industrial products. . . .

"The term drawing is here intended in its broadest sense, and includes mechanical as well as freehand, factual as well as interpretive, reports of form observed and also records of imagined forms. . . .

"Instruction technique would make use of subject materials such as natural forms, geometrical objects, models of line systems in space. . . . Principles of descriptive geometry will be used for the analytical dissection of space structures. A thorough grounding in projection systems is needed, beginning with orthographic and proceeding to isometric, cut-away, and perspective methods.

"Concurrently with analytical and geometrical work the student would be given practice in the freehand drawing directly from observation so that he may develop confidence in his ability to make notes on what he sees about him, relating this technique to the projection principles of the abstract studies.

"Practice in outline drawing would lead to exercises in the evocation of surfaces and textures of materials, and later to the uses of light and shade in the depiction of form in space. Parallel exercises using the same subject-matter for drawings having different purposes will

help give the student a concept of means at his disposal for differential delineation such as the following; drawing for accuracy of dimension and completeness of detail; for tactile qualities of the materials; for photographic realism; for emphasis on structural qualities; and simplification or distortion for interpretive purposes.

"Teaching would be conducted in such a way as to convey the idea that mechanical drawing and the freer kinds of representation differ only in purpose and method and can be mixed when needed. An important objective of the course would be to develop experience with different media and judgment in adapting the medium used to the purposes of the work. . . . Lettering should be studied as a means of developing sensitivity to line and proportion. . . .

"The purpose of this version of Graphics is to give (students) a rudimentary understanding of the importance of communication through vision and an elementary vocabulary for the development of later skill in expressing their ideas about form."

It should be obvious that this bears out much that I have said about the trends of engineering education.

Note that engineering drawing and descriptive geometry and a thorough understanding of projection systems are included as analytical tools in the world of visual understanding. They in a sense are the disciplinary elements in developing the ability to observe and in communicating such observation for a variety of purposes of which accurate description for manufacture is but one.

Consider here the application of the project method to some machine. The student would be required to draw it "for accuracy of dimension and completeness of detail". He would also be required to analyze some features of it by means of descriptive geometry. He would then have to draw it "for photographic realism", in other words make a good pictorial. Furthermore he would then branch into the freer area of drawing it "for tactile qualities of the material", "for emphasis of structural qualities" and for "simplification or distortion for interpretive purposes." Here choice of media and judgment about emphasis would come into play. Ability to observe accurately and completely would be at a high premium. The student would undergo a successive shifting of his focus of attention and become conscious of the surprising multitude of ways in which the same thing can be observed. This is the basic way to increase awareness.

If we give this course it is going to be a very difficult job at the outset but it seems to me to be one of the most stimulating challenges that we could possibly face. At any rate we have here a second new area to explore, another wide open world into which we can expand.

This highlights one other possibility that needs further emphasis. It has primarily to do with the development of the capacity to make good judgments. I spoke earlier of immersing the student in an unknown world and letting him work his way out. I also mentioned that judgment is a faculty which comes into play most

strongly when only relative answers are possible, when information is incomplete or over-abundant. I also said that attempts to teach judgment have developed the devices of the project method and the case method.

Now engineering drawing is ideally suited to the project method. It can require judgment concerning what to draw and how to draw it. To take the drawing of the simple machine mentioned above, we might say that the student is required to make all the judgments concerning its drawing for manufacture, its drawing for explaining how it works, and its drawing for purposes of sale. A drawing project course in which the student did one such complete job could very well follow whatever elementary work we might give.

To recapitulate we might say that we have three broad areas of operation.

(1) Our present major work of teaching engineering drawing and descriptive geometry for the direct purpose of developing competent draftsmen, and giving the engineer a basic tool of his profession.

(2) The teaching of analytical graphics as a power tool of intellectual attack on physical problems. Furthermore this offers us a major field of research for extending the horizons of our knowledge.

(3) The teaching of the ability to observe and a sense of form and design, - the development of creative ability in the whole field of visual representation.

Coupled with these is the possibility of new developments in the methodology of developing good judgment through the project method and the case method.

All that I have said has been cast in terms of engineering educational philosophy. Much of it is impossible for most of us to put into practice under existing conditions. Nor do I believe that any of us are now equipped with the staffs to do more than make a start, for no matter how competent men may be, much supplementary training and experience is always necessary for even the best of them to proceed competently into new areas.

It should be noted, however, that one of our problems has always been the development of a wide enough scope to attract first-rate young men into our field and to hold them there once we have done so. It certainly seems to me that the broadened outlook I have attempted to outline should offer a challenge worthy of such young men. It has room for those of us who enjoy the disciplined perfection of engineering drawing, for those who enjoy the analytical challenge of exploration in new geometric, graphics theory, and for those who are visually minded and enjoy the subtleties of perception involved in form and design.

I urge on you only the stubborn insistence that all geometric processes, that all things visual, that all things involving form and structure belong to graphics and that the teaching of them in their elementary and abstract phases must be our over-all goal if we are to continue to grow with engineering education.

PROBLEM BOOKS — YES OR NO

by

Professor Irwin Wladaver

and

Professor Lewis O. Johnson

College of Engineering
New York University

At least twenty-five thousand engineering college students of drawing use problem layout sheets, according to well known publishers. If to this number you add the students who use sheets that are not published, forty thousand would not be a wild guess. And if to these you add students using problem books in junior colleges, technical institutes, and teachers' colleges, a good estimate may be about sixty-five or seventy thousand.

Such near-unanimity in the use of problem books is startling. The advantages to engineering drawing teachers are quite clear and need no defense. But how about the students? It has hardly been definitely and publicly established that students learn more engineering drawing when they work with problem books and partial layouts than when they start from scratch and solve problems that they have to lay out themselves.

It seems right to say that it is our professional obligation as teachers to publish all facts that should influence our teaching procedures. If we say that students learn less when they use problem books, we should have some evidence to substantiate the claim. Assertions are not enough. If you say that students learn more when they use problem books, you should be able to support your position with facts. It is true, of course, that not all assertions are susceptible of proof. But it is also true that we ought to find every scrap of pertinent evidence and submit it to public scrutiny, letting the chips fall where they may.

Here are some scraps of evidence. You be the judge of their pertinence and value. At the New York University College of Engineering, beginning freshman take a 105-hour course in engineering drawing. Before September, 1950, we had never used problem layout sheets in this course. In the year ending in May, 1950, we had records of 360 students who had completed the course in the Day Division. They had taken four "objective" quizzes during the term. Of these students, 56 (15.6%) had done so well on their quizzes and laboratory work that we excused them from the final comprehensive "objective" examination. The remaining 304 students had to take the final examination. Let's call these the A-group, the group that did not use problem books.

We decided in September of the same year, 1950, that we'd give problem books a try. We selected a set that seemed pretty close to the kind of work we had given in the past year. We used the same textbook as in the year before; we used the same teaching staff; we gave the same lectures, showed the same slides and movies; and we gave the same four objective quizzes during the term. Of the 211 students that finished the course in the Day Division, 16 (7.6%) were excused from the final exam. The remaining 195 students took the same final comprehensive objective examination that we had used the year before. Let's call these the B-group, the group that did use problem books.

Which group, A or B, made higher scores on the examination? Before we tell you and before we try to analyze the results, there are certain assumptions we must make if our conclusions are to have the slightest validity.

The assumptions are these, that:

1. The two groups were about equal in whatever it takes to learn engineering drawing.
2. They had about the same background in the subject when they came to college.
3. The quality of instruction to both groups was the same - equally good or bad - and that the instruction was not biased in favor of or against problem books.
4. The four in-term quizzes had the same effect on the two groups in preparation for the final examination.
5. The problem book we used was a representative sample of available material of that nature.
6. Exemption of the "better" students did not materially affect the relative achievement of the two groups.
7. The final examination was not prejudiced in favor of either group.
8. The final examination was a reliable and valid measuring instrument for our purpose.
9. Higher scores on the final examination represented more learning of the subject of engineering drawing.

Now if you grant these assumptions - and there's no reason why you must - you may draw any conclusions that seem logical. If you have any reservations about any of the assumptions, your interest in comparing scores of the two groups can be only academic.

It may come as no surprise to you, although it did surprise us, to find that the A-group, the group that did not use problem books achieved the higher scores. First we'll tabulate the results and then analyze them:

	Day Students	
	A-Group: Without problem books	B-Group: With problem books
Number taking exam.	304	195
Number exempt	56	16
Mean Score.	83.2 points	77.4 points
Standard Deviation.	± 23.7 points	± 24.4 points
Standard Error of the Mean.	± 1.8 points	± 1.4 points

Difference between means = 5.8 points

Critical ratio = 2.54

At first glance, the difference of 5.8 points between the means of the two groups seems small. But a statistical analysis of the scoring is revealing. The standard deviations, or what you may call the general dispersion of the scores, are always important. They disclose how closely scores tend to cluster about the mean. When one group has a higher mean than another group, you might perhaps expect to find the scores of the high-scoring group more widely dispersed. But in this case, it didn't happen. The interpretation would be that the students who worked without problem books tended to cluster their scores just as tightly about the higher mean as the students who worked with problem books clustered about the lower mean score.

A statistical element that carries great weight in an analysis of the achievement of two groups is known as the "critical ratio." It is a ratio that suggests the degree of statistical significance attributable to a difference between two means. As we said earlier, the difference between the means of the A- and the B-groups was 5.8 points. The critical ratio of this difference turns out to be 2.5, a ratio of fairly substantial magnitude. With such a large number of students as we had, and assuming normal distribution of the factor under investigation, we have the right to say that the chances are 99 to 1 that the difference was not due to chance alone. We can't say for sure that the A-group scored higher just because the students did their own layouts. But we can say that whatever the cause was it was not sheer chance.

Yet if all this is so, how do you account for the exactly opposite result that came out of a study of scores made by two groups of Evening Division students? Again, we had two groups of students. The group we'll call the AA-group, 116 students, worked without problem books. The BB-group, 115 students, worked with problem books, the same set we had used in the Day Division B-group.

Evening Students

	AA-Group: Without problem books	BB-Group: With problem books
Number taking exam . . .	116	115
Number exempt.	45	25
Mean Score	70.4 points	79.8 points
Standard Deviation . . .	± 24.4 points	± 32.8 points
Standard Error of the Mean.	± 2.3 points	± 3.1 points
Difference between means = 9.4 points		
Critical ratio = 2.51		

This time the BB-group, using problem layouts, out-scored the group that did not use ready-made layouts. Furthermore, the critical ratio suggests that the difference was probably not due to chance.

The temptation to draw inferences and conclusions is very great but it would certainly be hard to support them with the relatively meager information we now have. Nevertheless, we shall make a few statements that may possibly be true if the original assumptions we have made or implied are acceptable. These statements may very well be considered hypotheses for further and more scientific study of the value of problem books in the study of engineering drawing.

1. When you have a comparatively homogeneous group of students just out of high school, your students will learn more about engineering drawing if they do not use problem books but do their own layouts.
2. The scores of such a group as a whole will be more compactly clustered about the mean of the group if problem books are not used.
3. But when you have a more heterogeneous group of students such as you are likely to get in evening schools of engineering, your students will learn more when they work with problem books than when they do their own layout work.
4. Even though the mean score of evening students will be higher with problem books than without, the dispersion of the scores will be wider when problem books are used.

One of our assumptions was that the exemption of the better students would not materially affect the relative achievement of the students. We feel impelled, however, to point out that the greater percentage of exempted students occurred in both the day and evening groups that did not use prepared layouts. It seems almost inevitable that had their scores been available, the groups not using problem books would have shown to even better advantage.

We are not deluding ourselves for a minute with the thought that we have settled anything. We expect to be challenged, and rightly so, for the problem is important. If other teachers are interested in planning a more thorough study of the effectiveness of problem books, we'd like to know. Perhaps we can help prevent some of the errors that are evident in what we have done so far.

One thing we are sure of. It is this: In our efforts to prepare young men and women for careers in professional engineering, we must do everything we can to lay the best possible foundation for future action - the foundation of greater knowledge.

DRAWING COMPETITION

CHICAGO -- Cash awards, slide rules, drafting equipment, and two one-year scholarships to Illinois Institute of Technology will be awarded as prizes in the fourth annual Chicago Public High School drafting competition.

The contest, sponsored by Illinois Tech's department of technical drawing, will be divided into five different competitions. The first is for 1B and 1A students in Drafting 1; the second for 1A and 2B students in Drafting 2; third for 2B and 2A students in Drafting 3; the fourth for 2A and 3B students in Drafting 4; and the fifth, in advanced machine drafting is open to students enrolled in drafting courses up to and including the 4A semester.

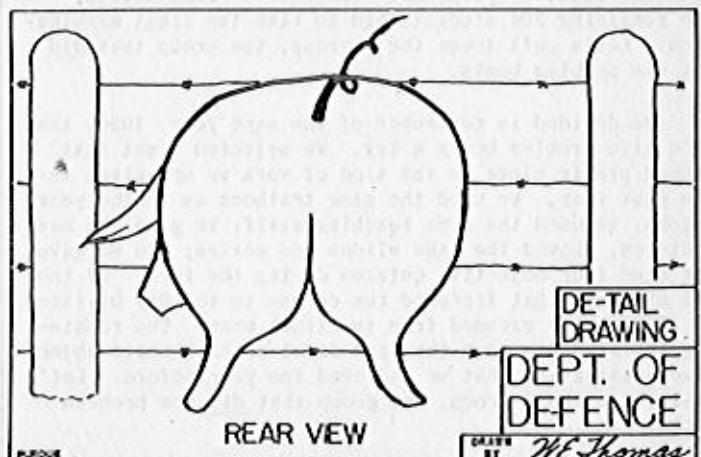

PERSONALITY SKETCH OF PROFESSOR RALPH S. PAFFENBARGER

by

Professor Paul E. Machovina

The Ohio State University

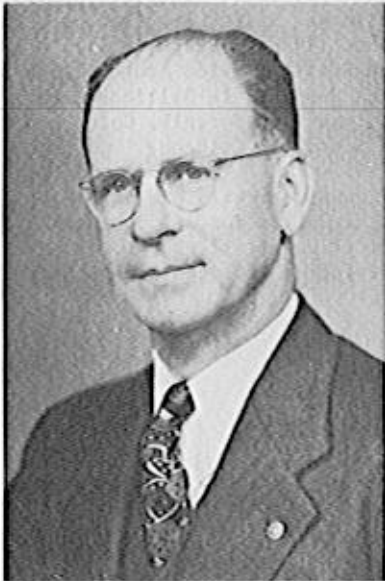

Many who attended the gathering of the Drawing Division at East Lansing, Michigan in 1951, were impressed by the fine program presented and by the ease with which it was conducted. As Director of the meeting and Chairman of the Division at the time, Professor Paffenbarger deserves much of the credit for the excellence of this meeting. It is characteristic of him, when confronted with such a project, to devote his time, energy, and abilities without reserve toward the success of the venture. Plans prepared in detail are carried out with a vigor startling to colleagues and disturbing to subordinates who must hasten to keep up. To persons working with him, Professor Paffenbarger seems twenty years younger than his calendar years because of his energy and because he looks like a young man. His whole life has been built on young ideas, friendliness, and a willingness to help others; consequently, his contributions to the life and welfare of his university, and to technical and civic organizations reach a considerable magnitude.

Coupled with the abilities and energy of Professor Paffenbarger is a personal friendliness and lack of false dignity which induces friends and subordinates alike to affectionately call him "Paffy." His sincerity and interest in students is characterized by his being the recipient of a fine brief case--a gift of appreciation by one of his classes. The narrator knows of no similar instance occurring in our Department. Similarly, he knows of no closer knit family than that of Professor Paffenbarger, and must remark upon the close relationship existing between Paffy and his sons--one which is enviable.

The character, personality and abilities of Professor Paffenbarger are those of a fine administrator; that he has developed and built on these fundamentals successfully is shown by the positions of responsibility he has been given in the many committees and organizations with which he is associated. No better example of his administrative ability can be cited than his leadership as Chairman of the Department of Engineering Drawing at The

Ohio State University, a position he assumed in 1944. Figuratively speaking, stepping into the shoes of the former chairman must have required courage, inasmuch as the former executive had been Dr. Thomas E. French, a nationally known figure, who had guided his department to a respected position in the field of engineering drawing education. Under Professor Paffenbarger, the department has continued to advance and to maintain an eminent position. Individual instructors are given important responsibilities and encouragement toward self-improvement, and in fulfilling these have surety in the knowledge that Paffy will press higher authorities for merited recognition. He early instituted important improvements and expansion of the physical plant. It is noteworthy that without these expansions, the handling of the "GI influx" would have been considerably more difficult. At its peak, the staff of the Engineering Drawing Department reached fifty members where the experienced teachers trained the new instructors and what might have been a chaotic situation became a well-organized project under Professor Paffenbarger's guidance.

The son of a dentist, Ralph Seal Paffenbarger spent his boyhood in the town of McArthur, Ohio, where he had been born April 25, 1894. Following graduation from high school, he entered The Ohio State University from which he later received the degrees of Bachelor of Electrical Engineering, Bachelor of Industrial Engineering and Master of science. His first experience in teaching was with the Chillicothe (Ohio) High School where he taught mathematics and drawing from 1915 to 1917; simultaneously, he was employed as an engineer at the Mead Pulp and Paper Company. Following this, Paffy accepted an engineering position with the Ohio Fuel Gas Company of Columbus, Ohio, where he was employed until 1919, except for military service during World War I. During the war he served as Lieutenant of Infantry, and at the close was Instructor in Small Arms at Camp Lee, Virginia. Accepting an instructorship in Engineering Drawing at The Ohio State University in 1919, he embarked upon the principal work of his lifetime. Promotions in rank were received regularly with that of full professor in 1936. As has been mentioned he was made Chairman of the Department in 1944, and continues to serve in that capacity. This year will see the completion of thirty-four years of continuous service to Ohio State.

University and engineering faculty committees on which Paffy is serving or has served include: Chairman of the Commencement Committee--seven years, Athletic Board--Secretary for three years, University Scholarship Committee, Audio-visual Materials Committee, Chairman of the Diploma Committee, Chairman of the Lamme Medal Committee, Chairman of the Ohio Section ASEE Committee, College Agenda Committee, and College Schedule Committee.

Professor Paffenbarger has also given considerable service in office and on committees of the ASEE and the American Standards Association. For the ASEE, these include: Executive Committee of the Drawing Division, Chairman of the Advanced Credits Committee, Chairman of the Engineering Drawing Division, Member of the General Council, National Membership Committee, and Director of the Engineering Drawing Summer School in 1951. Committees for the American Standards Association include:

Standard for Drawing and Drafting Practice (Y-14), and Standard for Graphic Presentation (Y-15); in addition, he is Secretary of the Y-14 Committee, Secretary of the Y-14 Executive Committee, and Chairman of the Y-14 Editing Committee.

His memberships and activities in honorary, professional, social, and fraternal organizations and listings include: Who's Who in Engineering, Tau Beta Pi, Alpha Pi Mu, Phi Kappa Tau, AAAS, ASEE, ASME, Registered Engineer (State of Ohio), American Legion (Commander 1945-46), Ohio State University Faculty Club (President 1949-50), Rotary Club of Columbus, University Lodge 631 F&AM (Past Master 1931), York Chapter 200 RAM (Past High Priest 1932), York Council 115 R&SM (Past Master 1938), Columbus Commandery No. 69 K.T., and Scioto Consistory AASR.

In the field of authorship, Professor Paffenbarger has prepared a number of articles and papers on the subject of Engineering Drawing and on the administration of a drawing department. He has contributed to textbooks

dealing with his field such as "Mechanical Drawing" by French and Svensen and "Engineering Drawing" by French, and assisted extensively in the last two revisions of the latter text. He served as a technical advisor in the production of a series of motion pictures and film strips used in the teaching of engineering drawing.

Professor Paffenbarger married Viola Link of Sandusky, Ohio, November 4, 1918. They are justly proud of their three children, Ralph, Jr., Tom, and Carolyn, and their four grandchildren. Ralph Jr., is a surgeon with the U.S. Public Health Service and on the Research Staff of Johns Hopkins Hospital in Baltimore, Maryland; Tom is a practicing attorney in Norwalk, Ohio; and Carolyn is a senior in High School in Columbus.

Ralph Paffenbarger, with his many fine qualities, is a model one might follow for a successful life. He can well be the selection of all who know him as their example of clean living--a real gentleman, Ralph Seal Paffenbarger.

AN INDEX TO THE PAST AND TO THE FUTURE

by
Irwin Wladaver

If an index has no purpose except to refer to past publications, then there's nothing left to say. All we can hope is that it's reasonably complete and accurate, that the headings are wisely selected, that there are enough but not too many cross-references, and that the compiler knew the alphabet.

But in my opinion the recently distributed index to seventeen years of the Journal of Engineering Drawing can be a mine of ideas for future publications. All you have to do to exploit it is to dig a little. I'll explain what I mean in a minute.

First I want to say that the past 48 issues of the Journal are a veritable treasury of valuable information and ideas. I know, because I had to read many articles I had never seen and many that I had brushed off. In order to index them, I simply had to know what was in them.

How, for example, would you classify an article with the apparently silly title, "Quinine"? Well, get your hands on a December, 1936, Journal if you want to know how industrial firms appraised our students seventeen years ago. Do you think their attitude has changed much since then? Ask Professor Levens; he wrote the article (but I have no way of knowing whether he gave it the not so silly title).

Would you like to get stirred up about some of your pet ideas about the education of engineers? Read what Professor William Griswold Smith had to say. Chances are you'll want to pound on your typewriter in agreement or in rebuttal. Professor Slantz and others usually did.

I said a minute ago that you could dig out some ideas to write about. I'll be specific and, I hope, challenging. For example, an early contributor to the Journal, Professor Eks, was practically vitriolic in his condemnation of problem layout sheets in descriptive geometry. (You can find the reference in the Index.) Was he right to condemn them? Did he try them out? Did he refuse on principle? Were his assumptions acceptable? Do you use layouts? Why? Is it just a lazy teacher's way of getting through a semester with a minimum of exertion?

Most of all, do you have any facts. Facts, not guesses. Or how should we get the facts? Or isn't any of this worth investigating and reporting? Is the line of least resistance a straight line?

Are you interested in visualization - that almost mystical ability that some people claim is delivered along with the final grade in descriptive geometry? Has any experimenting been done? Do you have some facts, some ideas, some objections?

Do we really know what we're doing when we give examinations? What are we examining? Should we give exams at all? Why? And what is a reliable exam? A valid one?

The point I'm trying to make is that of course you can use the Index to see what's been said and what's been done. But if you look carefully, you can see at the same time what has not been said and what has not been done.

Maybe you're the one to say it. Maybe you're the one to do it. How about it?

ACCURATE REPRESENTATION OF CIRCLES ON PICTORIAL DRAWINGS

by
 Professor S. B. Elrod
 Purdue University

One of the oldest problems confronting those of us engaged in making pictorial drawings is the pleasing, accurate, economical representation of curves - particularly of circles. The novice in this field usually learns some of the conventional methods and is pleased with the result. The practitioner probably uses templates in nearly all cases. However, some of us do not have templates and often the templates do not fit, then it becomes necessary to use some form of accurate construction.

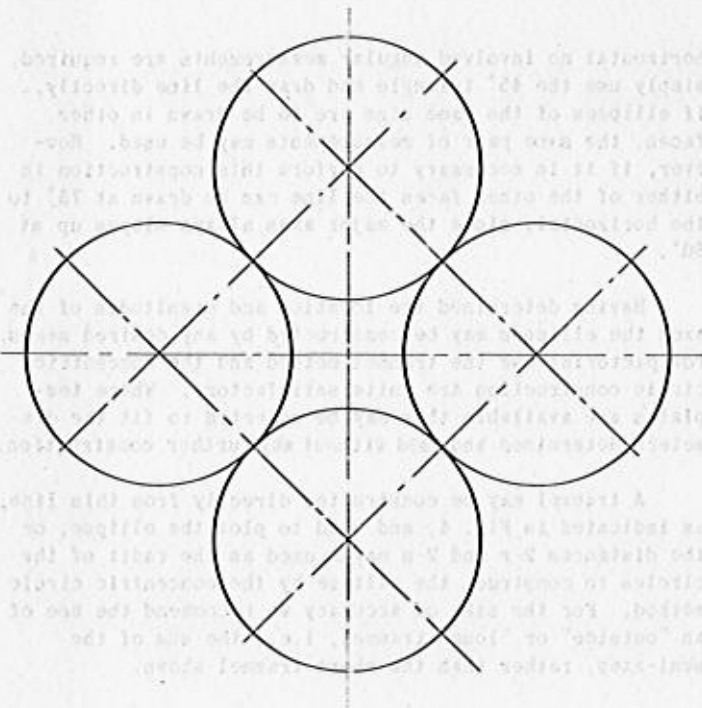

Fig. 1a

The saddest case is that where accurately constructed ellipses, produced either graphically or by templates, and conventionally produced curves appear on the same drawing; the result being, to say the least, unpleasant to the practiced eye.

Fig. 1a represents the normal view of four tangent circles of equal diameter. Fig. 1b shows these four same circles in isometric, drawn accurately by the conventional four-center or "W" method. It may be noted that besides producing an unpleasant shape these circles are no longer tangent, but due to the inherent distortion of the method they either intersect or miss completely. This same difficulty occurs often, particularly in schematic piping

diagrams, gear layouts, etc. Fig. 1c shows this same set of circles constructed from their major and minor diameters. Not only are the individual circles more pleasing to the eye, but this drawing shows them in their proper relation to each other.

Many methods have been proposed to improve the appearance of so called ellipses which are drawn with compasses using several different radii. Most of these

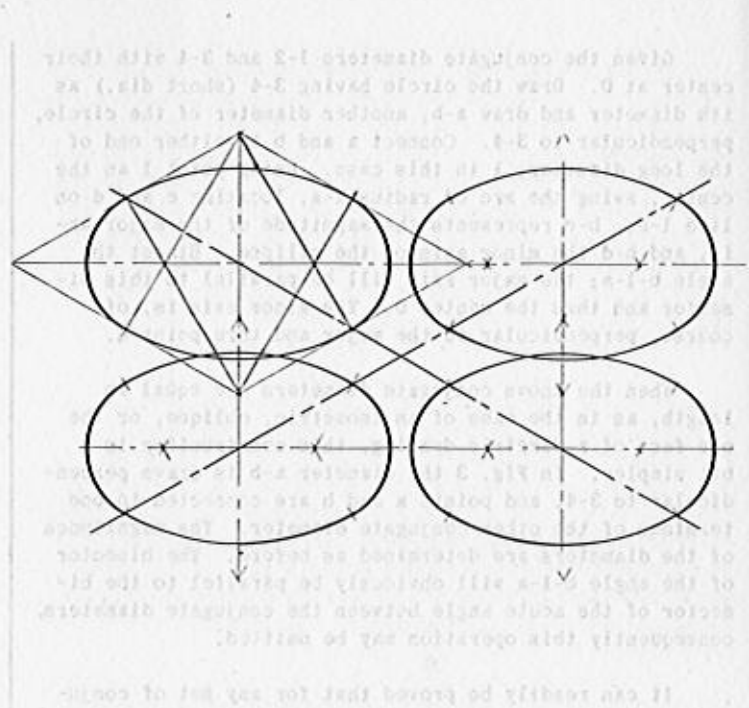

Fig. 1b

methods appear cumbersome, hard to remember and teach, and require extreme accuracy. As a result of our effort to find a simple, easily remembered, and easily taught construction we feel that the following presentation will fill a great gap in the field of pictorial drawing.

DETERMINATION OF AXES AND CONSTRUCTION OF ELLIPSES FROM CONJUGATE DIAMETERS.

The magnitude and position of the major and minor diameters of an ellipse may readily be determined from any known pair of conjugate diameters as shown in Fig. 2. This method is given in popular texts, therefore details and proof are omitted here.

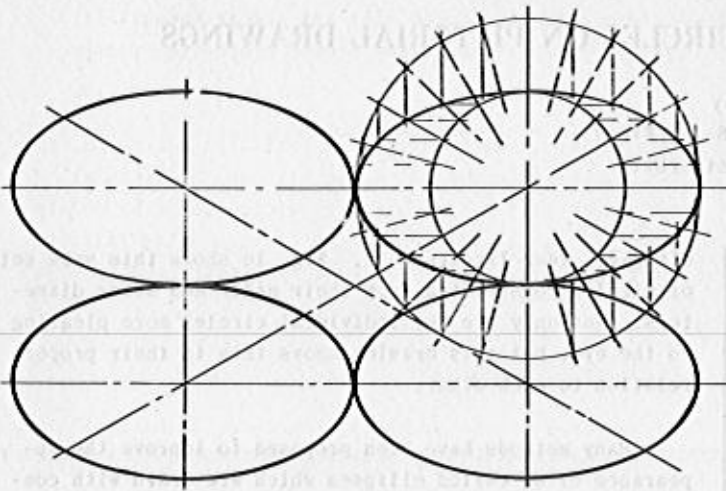

Fig. 1c

Given the conjugate diameters 1-2 and 3-4 with their center at 0. Draw the circle having 3-4 (short dia.) as its diameter and draw a-b, another diameter of the circle, perpendicular to 3-4. Connect a and b to either end of the long diameter, 1 in this case. Using point 1 as the center, swing the arc of radius 1-a, locating c and d on line 1-b. b-c represents the magnitude of the major axis, and b-d the minor axis of the ellipse. Bisect the angle b-1-a; the major axis will be parallel to this bisector and thru the center 0. The minor axis is, of course, perpendicular to the major and thru point 0.

When the known conjugate diameters are equal in length, as in the case of an isometric, oblique, or the one face of a dimetric drawing, this construction is a bit simpler. In Fig. 3 the diameter a-b is drawn perpendicular to 3-4, and points a and b are connected to one terminus of the other conjugate diameter. The magnitudes of the diameters are determined as before. The bisector of the angle b-1-a will obviously be parallel to the bisector of the acute angle between the conjugate diameters, consequently this operation may be omitted.

It can readily be proved that for any set of conjugate diameters the line d-1 will always intersect the major and minor axes at 45° . Furthermore the mid-points of segments b-c and b-d will always lie on the major and minor axes respectively. If a line were to be drawn thru point 2 at 45° to the axes the distances from point 2 to the major and minor axes will be exactly the same as those found by bisecting b-c and b-d. Thus the entire process may be discarded, and the same results obtained by simply drawing the 45° line 2-r-s as shown in Fig. 4.

The construction may be even more simple when drawing isometric ellipses. In Fig. 5 the directions of the major and the minor axes are easily determined for the ellipses in all three faces.

The line 2-r-s is drawn at 45° to the axes. The distance 2-r is the magnitude of the semi-minor, and 2-s the semi-major axis.

Since the major axis on the top face is always

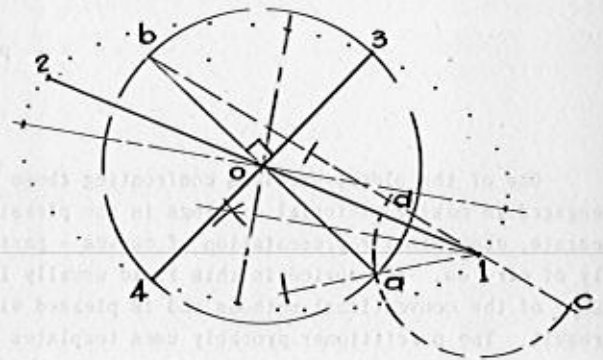

Fig. 2

horizontal no involved angular measurements are required, simply use the 45° triangle and draw the line directly. If ellipses of the same size are to be drawn in other faces, the same pair of measurements may be used. However, if it is necessary to perform this construction in either of the other faces the line can be drawn at 75° to the horizontal, since the major axes always slopes up at 60° .

Having determined the location and magnitudes of the axes the ellipses may be constructed by any desired means. For pictorial use the trammel method and the concentric circle construction are quite satisfactory. Where templates are available they may be selected to fit the diameters determined and used without any further construction.

A trammel may be constructed directly from this line, as indicated in Fig. 4, and used to plot the ellipse, or the distances 2-r and 2-s may be used as the radii of the circles to construct the ellipse by the concentric circle method. For the sake of accuracy we recommend the use of an "outside" or "long" trammel, i.e., the sum of the semi-axes, rather than the short trammel shown.

PARALLELOGRAM METHOD

The more universal parallelogram method is one which lends itself well to all forms of pictorial drawing. For any set of conjugate diameters, or the enclosing rhomboid, the construction is as shown in Fig. 6. This is a common method found in many texts, therefore the following explanation is quite brief.

Each half of the longer conjugate diameter is divided uniformly and the halves of the short sides of the enclosing rhomboid is divided uniformly into the same number of parts. Lines drawn from one end of the shorter conjugate diameter thru the points on the longer diameter will intersect lines drawn from the other end of the same diameter to corresponding points on the end of the rhomboid (on the same side of the long diameter). The intersections will lie on the desired ellipse: for example, line a-2 intersects b-2', likewise a line b-2 would intersect a-2', and both points would lie on the curve.

The upper right quarter of this figure illustrates a graphical method of dividing the sides and diameters in the proper proportions by means of diagonals and parallels. We recommend that this scheme be used in preference dividers, etc.

In the case of a perspective projection this graphical method is almost mandatory. The parallels will of course be drawn thru the proper vanishing point. The

divisions thus produced will all appear unequal in length, but will be in the proper proportion perspective-ly.

In the example shown each 'half' is quartered, thus locating sixteen points on the ellipse. Additional points may be found on any part of the curve by merely bisecting the distances between corresponding pairs of points and drawing another pair of lines.

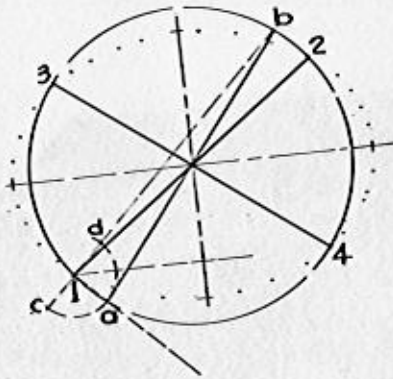

Fig. 3

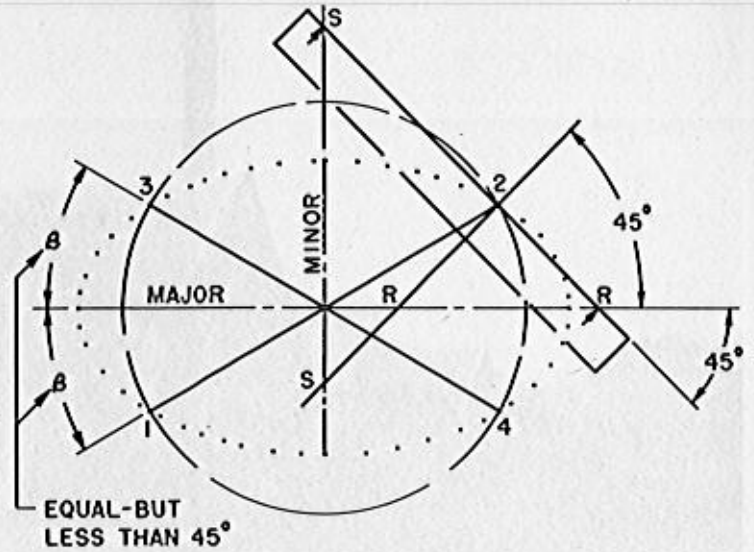

Fig. 4

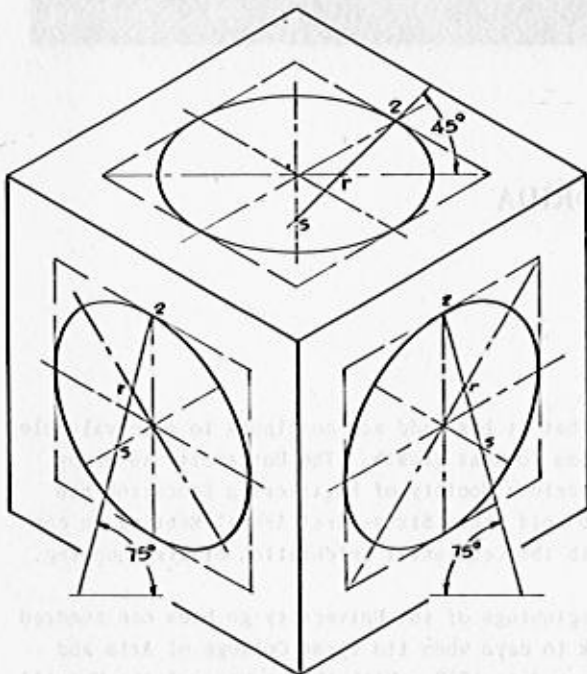

Fig. 5

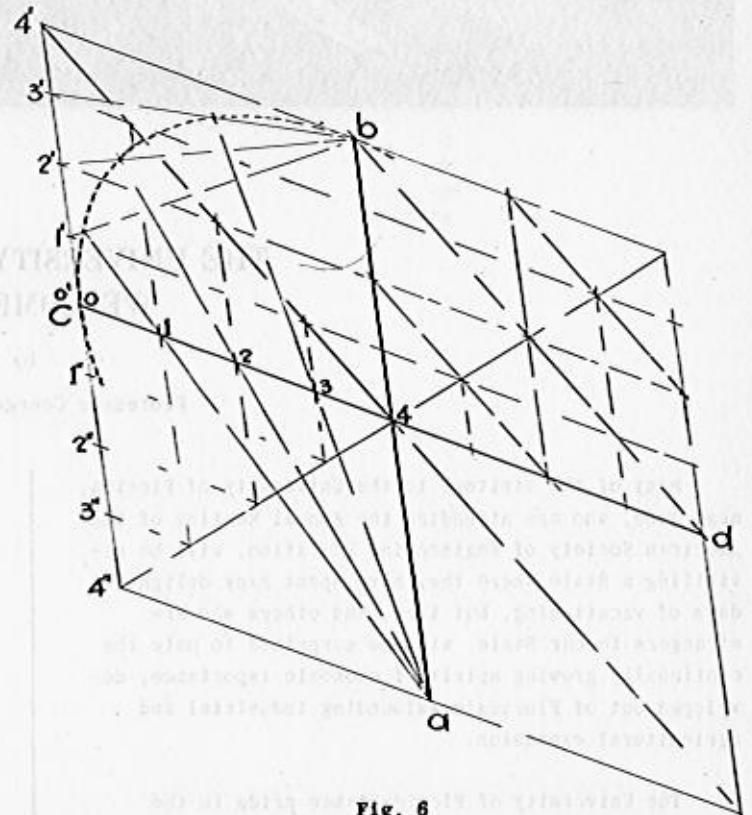
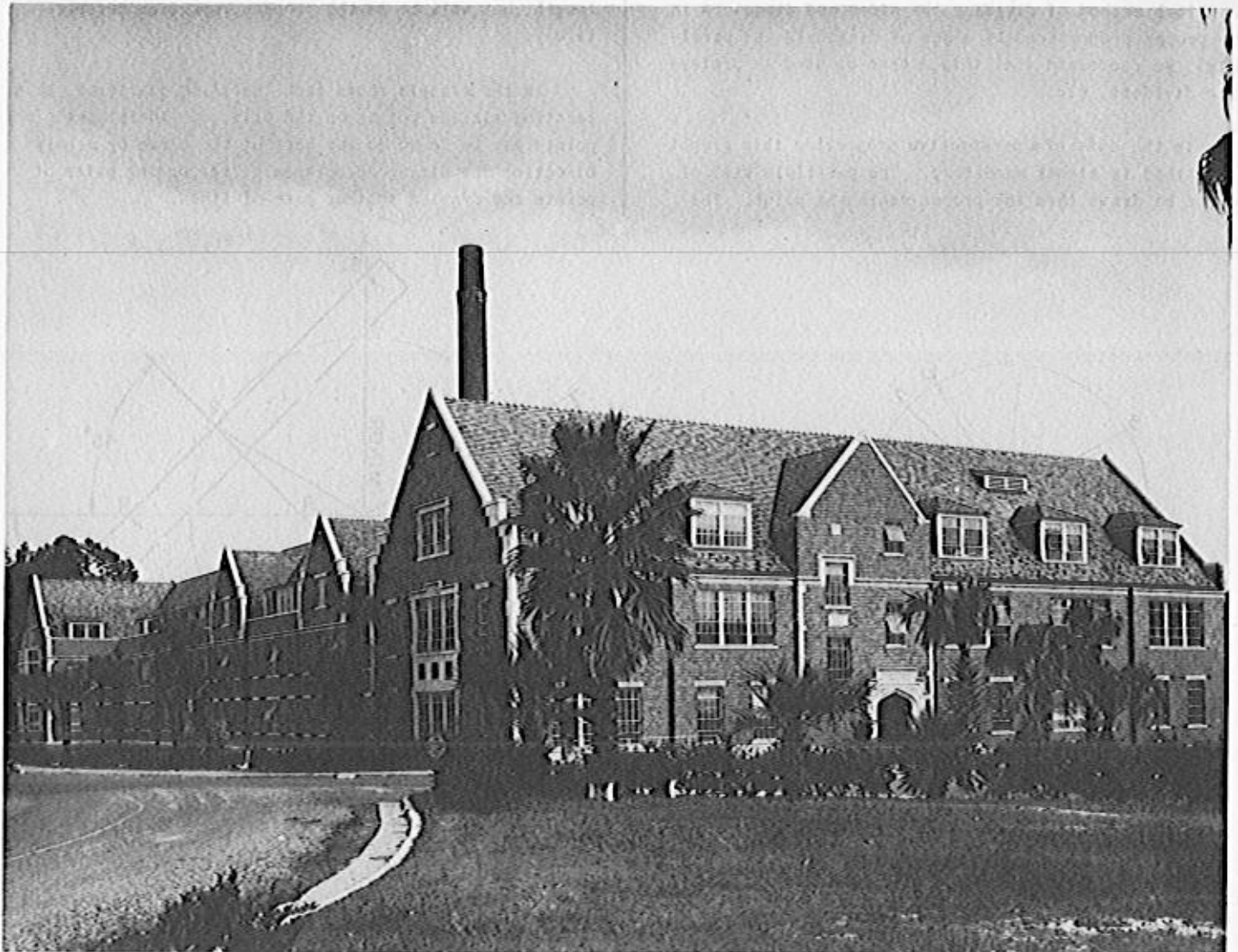

Fig. 6



THE UNIVERSITY OF FLORIDA WELCOMES YOU

by

Professor George O. Phelps

Many of the visitors to the University of Florida next June, who are attending the Annual Meeting of the American Society of Engineering Education, will be re-visiting a State where they have spent many delightful days of vacationing, but they, and others who are strangers to our State, will be surprised to note the continually growing spirit of economic importance, developed out of Florida's astounding industrial and agricultural expansion.

The University of Florida takes pride in the

knowledge that it has made and continues to make valuable contributions to that growth. The University is happy that the American Society of Engineering Education has seen fit to hold their Sixty-First Annual Meeting in connection with the Centennial Celebration of its founding.

The beginnings of the University go back one hundred years, back to days when its first College of Arts and Sciences opened in 1853. With the passage of the Morrill Act, the College of Agriculture, College of Engineering, and the Agricultural Experiment Station came into being.

It is a matter of special interest to educators that as far back as 1905, the State Legislature wisely abolished the then existing six State Colleges and provided in their place two new institutions of which the University of Florida is one. This Act of the Legislature provided for a Board of Control for the two newly created institutions composed of seven members representing the seven geographical sections of the State, all to serve without compensation except for travel and incidental expenses.

Under the present program the University operates a lower division and an upper division. During the first two years the student is given basic comprehensive courses and essential background courses in preparation for the specialized fields. The junior and senior years are devoted to studies in the several specialized courses. From a pre-war registration of 3,000 the university has grown until the student body now numbers nearly 10,000. The Engineering staff has increased to approximately 240, inclusive of the Experiment Station personnel. It is interesting to note that there were twice as many freshmen engineers enrolled at the University of Florida in 1951 as compared to 1941.

The University of Florida is located in Gainesville, a city of about 30,000 people situated in the north central part of the State. Due to its location, you will find it convenient to visit many of Florida's unique attractions. Fernandina, site of some of Florida's most colorful history; Jacksonville, northern metropolis; St. Augustine, America's oldest city, with its ancient Spanish fort and historical buildings, its alligator and ostrich farms, and museums; Marineland, with its trained porpoises and vast display of live marine life; Daytona Beach, where auto and motorcycle races are run on the broad smooth sands; the Ringling Art Museum at Sarasota; the sponge fleet at Tarpon Springs; mermaids at Weeki-wachee Springs; water skiing at Cypress Gardens; the Bok Tower; Silver Springs; the Palm Beaches; the Gold Coast's famed Miami, and Key West. White Springs on the Suwannee River is the site of the Stephen Foster Memorial. One of the most unusual motor trips is that from Miami to Key West over 122 miles of the famed Overseas Highway. The Everglades National Park offers well-marked trails through a vast wild-life sanctuary. Tours of some of these points are being arranged for the conference and College of Engineering staff members will be on hand to help you plan your trip through the State.

The Campus of the University of Florida is noted for its palms and pines. Although the new buildings (Administration, Student Service Center, Engineering, Gymnasium, Dormitories) are modern, they are designed to blend with the original Gothic type of architecture. The Auditorium and many of the older buildings are traditionally

vine-covered. The General Library contains over 500,000 books. The Florida Museum, containing historic and natural exhibits of Florida life, is located in the downtown Seagle Building. An interesting area in the new Administration Building is the Florida Center of Clinical Services. The Cancer Research Laboratory is engaged in important sponsored research. On and off campus, the Agricultural Experiment Station covers about 7,500 acres. Florida Field Stadium seats approximately 40,000 people. The Gymnasium has a capacity of about 7,000 people. The Florida Union is the official center of student activities. The new air-conditioned Student Service Center is a gift of the alumni and houses "The Hub" soda fountain, the Post Office, and the Campus Bookstore. Here you may leave your laundry and cleaning for 24-hour service.

The facilities of the Engineering Experiment Station include all of the equipment of the College of Engineering now valued at about \$3,000,000. When completed, the new Engineering Building will cover 250,000 square feet. This will provide Electrical, Mechanical, Industrial, Chemical and Civil Engineering laboratories, classrooms, administrative offices, and the air-conditioned Engineering Sciences Library. Aeronautical Engineering and the wind tunnels are located in the Hangar. Nearby is the Radar Tower used for hurricane detection. Incidentally, this service to the State has saved lives and dollars and seems to have driven the storms away from Florida.

Although Florida does enjoy mild winters and made its reputation as a winter resort, the State is fast becoming one of the nation's most popular of summer vacation lands. Summer nights are cool following the warmest days. Occasionally summer heat waves from the North and West penetrate into the Florida peninsula as do nation-deep cold fronts of winter; but when it is uncomfortably warm here, it is invariably warmer there; and when it is chilly here, it is much colder there. This statement can be verified in the weather report in your daily newspaper. Last year nearly 1,500,000 tourists came to Florida in midsummer for rest, recreation and physical refreshment. Nearly 2,000 miles of salt water shoreline are crowded with carefree vacationers. Fishing is at its peak in some 30,000 fresh water lakes and rivers as well as deep-sea angling and the popular surf-casting. The Annual Tarpon Roundup at St. Petersburg runs from May through July.

The plans for the June Convention include a varied program for the ladies. Supervised nursery and playground facilities will be available, as well as a list of "sitters." We hope you plan to bring the family and enjoy a real Florida vacation. Once you get Florida sand in your shoes, we know "you-all" will come again.

SIMPLIFIED CALCULATIONS FOR SPACE PROBLEMS

by

Robert M. Johnston, Instructor of Drafting
California State Polytechnic College

There seems little doubt that space problems confronting the practicing engineer are most satisfactorily solved graphically by applying the principles of descriptive geometry. These graphical solutions usually require much less time than calculated results and yet, with reasonable care, slide rule accuracy can be expected.

On occasion, however, there will certainly occur problems that require precise mathematical treatment. In these cases, recourse is usually made to solid analytic geometry, requiring considerable ingenuity and mental gymnastics to cope with the varied situations that arise.¹

Possibly, we are overlooking an equally effective mathematical approach to these problems which requires no more than a knowledge of descriptive geometry plus elementary trigonometry. It should be satisfying to the student to know that he can obtain precise mathematical results for his space problems without becoming involved in higher mathematics.

Since orthographic drawing pertains to right angles, i.e., mutually perpendicular image planes and lines of sight, one might suspect that space problems solved by multi-view projection can be broken down into right triangles. This appears to be true, and will be the basis for solving two typical descriptive geometry problems.

First of all, a graphical solution of the problem is made. This serves as a picture on which to record calculated angles and distances. As each calculation is completed, it is convenient to scale the drawing for these angles and distances as a rough check on calculations. Although only right triangles are encountered in these

examples, ability to handle simple proportion involving similar triangles and a knowledge of the sine and cosine laws is also useful. It is important to realize that all calculated angles and distances are projected angles and distances, having no spatial significance except on the image plane where they appear.

The pictures included show for each problem² the graphical solution before and after the mathematical treatment. The progressive steps are numbered and shown near each calculated result; the order of the steps might vary slightly with the individual, but must proceed from the original given views to the auxiliary views, and sometimes back again, much in the same order in which the graphical steps were performed.

PROBLEM ONE

Connect skewed pipe lines AB and CD using two 45° elbows. Using centerlines only, find the two points of connection, and the true length of this connecting pipe.

CONDENSED SUMMARY OF CALCULATIONS

Assume the cone diameters to be 4.0000'. Then the altitude and base radii of the cones as seen in the plan view will be 2.0000'.

Step (1) By inspection, this angle is exactly 30°, since the cones are the same size and c_1k_1 must bisect the angle formed by the slant heights of the cones. More calculations would be necessary if the cones were not the same size, i.e., elbows with different bend angles.

Step (2) Distance = $2.0000 \times \tan 30^\circ$
= 1.1547'

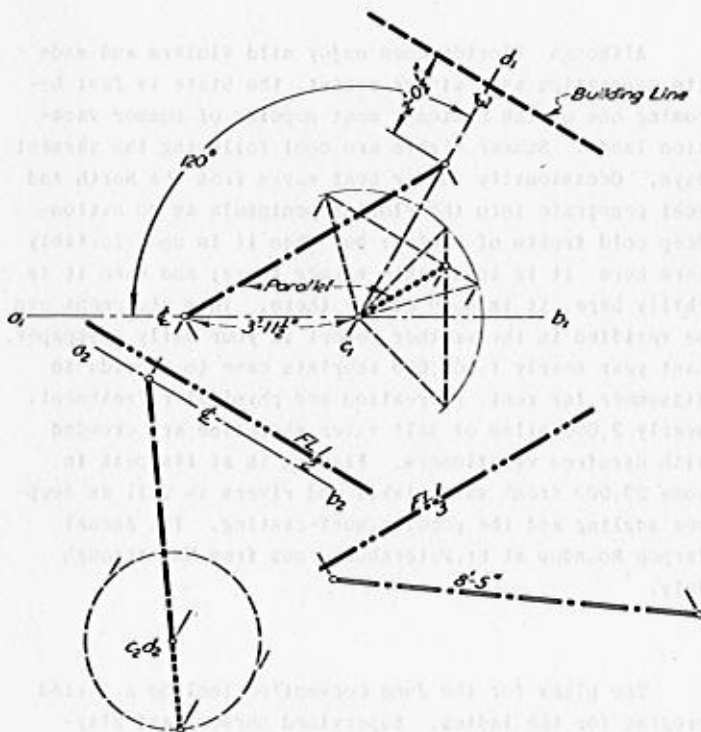

Fig. 1
(Graphical Solution)

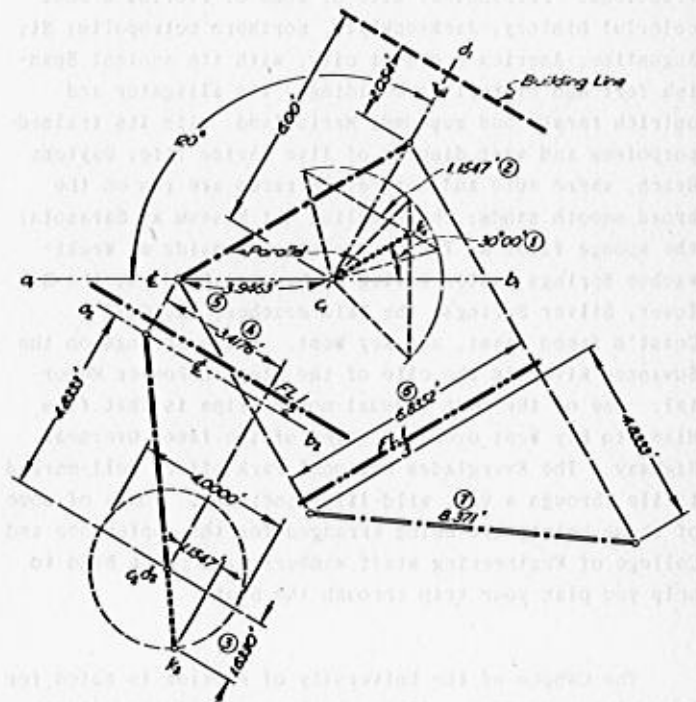

Fig. 2
(Mathematical Solution)

¹ Professors Hood, Wellman, and others in their texts suggest a formula from solid geometry for calculating the distance between two points in space. This is most useful for finding the true lengths of lines and the angle between intersecting lines.

² Problems 9-16-23 and 9-7-1, Applied Descriptive Geometry, 3rd. Edition, F.M. Warner.

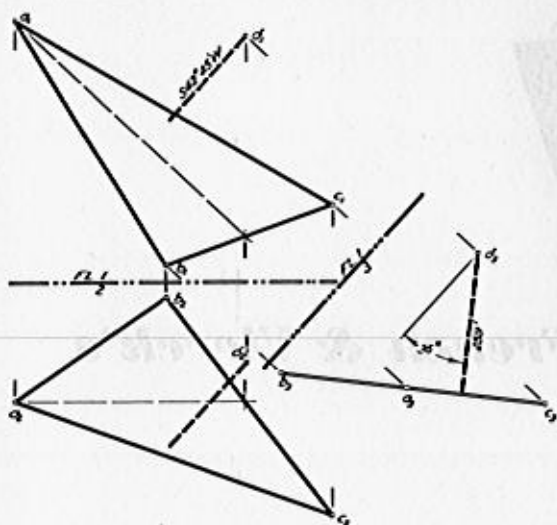

Fig. 3
(Graphical Solution)

Step (3) $Distance = \sqrt{(2)^2 - (1.1547)^2}$
 $= 1.6330'$

Step (4) $\frac{1.6330}{1.1547} = \frac{4.8333}{distance}$ (Similar triangles)
 $Distance = 3.4176'$

Step (5) $Distance = \frac{3.4176}{\cos 30^\circ} = 3.9463'$

Step (6) $Distance = 3.4176 \times 2 = 6.8352'$

Step (7) $Distance = \sqrt{(4.8333)^2 + (6.8352)^2}$
 $= 8.3714'$

PROBLEM TWO

Find the slope and bearing of the shortest distance from point D to plane ABC.

The two examples shown in Figures 3 and 4 illustrate the general method of attack that can be used on descriptive geometry problems whenever calculated results are necessary. Obviously, this is not a short-cut method; there is nothing particularly neat or refined about the solution. In its favor, however, I mention a few points for consideration.

1. When studying descriptive geometry, the conscientious student is more likely to be satisfied with his own progress if he knows at all times he could apply simple trigonometry directly on his drawing and get an exact answer.
2. The graphical solution can be scaled for a step-by-step check against obvious errors in calculations.
3. It seems doubtful that the average engineering student has the necessary background in solid analytic geometry and calculus, and possesses the ingenuity to quickly set up equations for the varied situations as they occur.
4. For the practicing engineer whose routine work seldom calls for the exact answer to a descriptive geometry problem, here is a method that is readily understandable, and is applicable to practically any situation that might arise.

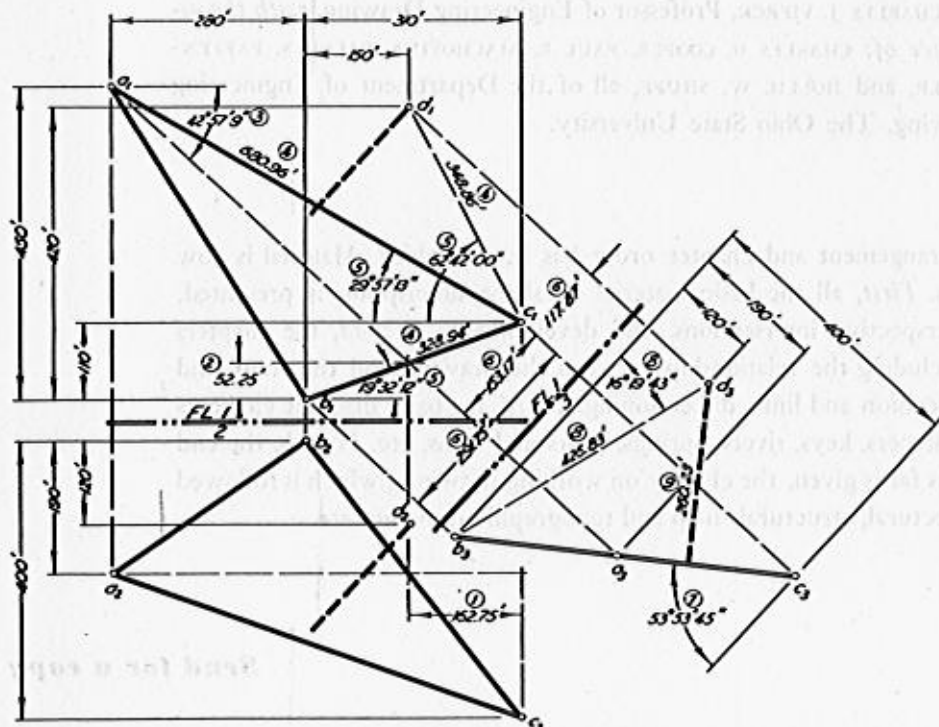

Fig. 4
(Mathematical Solution)

Step (1) $\frac{400}{310} = \frac{210}{dist.}$ (Similar triangles)
 $Distance = 162.75'$

Step (2) $\frac{100}{310} = \frac{dist.}{147.25}$ (Similar triangles)
 $Distance = 52.25'$

Step (3) $\tan \text{ of angle} = \frac{397.75}{427.25} = 0.93095$
 $Angle = 42^\circ 57' 09''$
 Note: This angle fixes fold-line 1/3 as well as the bearing of the required perpendicular.

Step (4) Projected lengths seen in plan view:
 $b_1c_1 = \sqrt{(110)^2 + (310)^2} = 328.94'$
 $a_1c_1 = \sqrt{(590)^2 + (340)^2} = 680.96'$
 $c_1d_1 = \sqrt{(310)^2 + (160)^2} = 348.86'$

Step (5) Angles with respect to fold-line 1/2
 $\tan \angle b_1c_1 = \frac{110}{310}; \angle = 19^\circ 32' 12''$
 $\tan \angle a_1c_1 = \frac{340}{590}; \angle = 29^\circ 57' 13''$
 $\tan \angle c_1d_1 = \frac{310}{160}; \angle = 62^\circ 42' 00''$

(Continued on page 24)

Acknowledgement is due Professor Frank M. Warner of the University of Washington for his original thinking and encouragement that prompted me to prepare this paper.

a new 8th edition

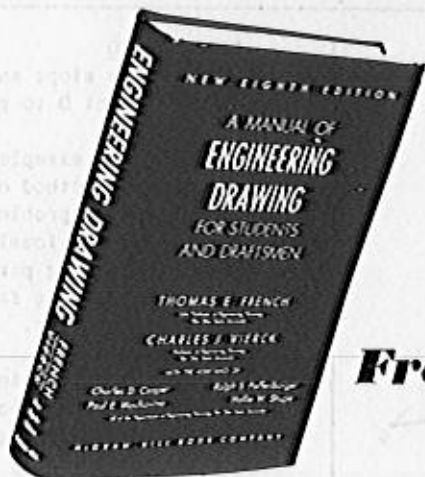

French & Vierck's

ENGINEERING DRAWING

**715 PAGES
\$6.00**

**a leader
since 1911**

Of all the books published in this field, *Engineering Drawing* has been, since its publication in 1911, the standard work on the subject. The new revision is designed to maintain that position of leadership.

The authors: THOMAS E. FRENCH, Late Professor of Engineering Drawing, and CHARLES J. VIERCK, Professor of Engineering Drawing, *with the assistance of:* CHARLES D. COOPER, PAUL E. MACHOVINA, RALPH S. PAFFENBARGER, and HOLLIE W. SHUPE, all of the Department of Engineering Drawing, The Ohio State University.

In this new edition a revised arrangement and chapter order has been evolved. Material is now arranged in four basic divisions. *First*, all the basic material on shape description is presented, including pictorial sketching, perspective, intersections, and developments. *Second*, the chapters on size description are given, including the relationship between the drawing and the shop, and also the advanced material on precision and limit dimensioning. *Third*, the basic machine elements are discussed — screw threads, fasteners, keys, rivets, springs, gears and cams, etc. *Fourth*, the end point of all material included thus far is given, the chapter on working drawings, which is followed by the related specialties, architectural, structural, map and topographic drawing, etc.

Send for a copy on

McGRAW-HILL BOOK

330 West 42nd Street

(Continued from page 30)

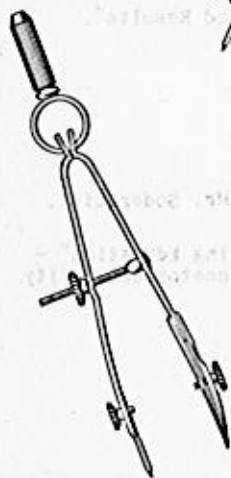

FEATURES

The material on screw threads and fasteners has been entirely rewritten to conform to the new unified thread standards.

The first chapter now outlines the whole subject and gives an excellent account of what engineering drawing is.

Architectural material is virtually all new, and the new modular and grid systems are explained and illustrated.

Several new geometrical methods have been added to the chapter on Applied Geometry, which has been completely rearranged.

Working sketches have been included in the section on working drawings.

The chapter on orthographic reading is almost wholly new, and is now the most complete treatise on the subject available.

The treatment of keys, rivets, and springs has been contemporized and follows new standards and practices.

The material on welding is new and conforms to new ASA Standard.

Two problem books will be available for use with the new edition. One will be a combination of 8½ x 11 and 11 x 17 size sheets. The other will include only 8½ x 11 size sheets.

Textfilms are also available to accompany ENGINEERING DRAWING. Information regarding textfilms may be secured from the Textfilm Department of the McGraw-Hill Book Company.

approval now

McGraw-Hill Book Company, Inc.

New York 30, New York

(Continued from page 21)

Step (6) Distance between projectors relating views (1)

and (3).

$$b \text{ to } c = 328.94 \times \sin 62^\circ 29' 21''$$

$$= 291.75'$$

$$c \text{ to } a = 680.96 \times \sin 12^\circ 59' 46''$$

$$= 153.17'$$

$$c \text{ to } d = 348.86 \times \sin 19^\circ 44' 51''$$

$$= 117.87'$$

Step (7) \tan of slope of plane ABC = $\frac{400}{291.75}$

$$\text{Slope} = 53^\circ 53' 45''$$

$$\text{Slope of required perpendicular} =$$

$$(90^\circ) - 53^\circ 53' 45'' = 36^\circ 06' 15''$$

Step (8) Projected length of $b_3d_3 =$

$$\sqrt{(120)^2 + (409.62)^2} = 426.83'$$

$$\tan \text{ Angle } b_3d_3 \text{ makes with foldline } 1/3 =$$

$$\frac{120}{409.62}; \angle = 16^\circ 19' 43''$$

Step (9) Shortest distance from D to ABC =

$$426.83 \times \sin 37^\circ 34' 02'' = 260.23'$$

**PROGRAM
ANNUAL MEETING
of the
ENGINEERING DRAWING DIVISION OF THE A.S.E.E.**

Monday, June 222:00 P.M.

(1) "British and American Methods of Expressing Tolerances on Drawing" - Professor S.B. Elrod - Purdue University.

(2) "Validity of Examinations" - Professor I. Wladaver, New York Univ.

(3) "Transfer of Ideas to Develop Creative Thinking" - Professor Matthew McNear, Univ. of Maine.

6:00 P.M.

Engineering Drawing Executive Committee Dinner Meeting.

Tuesday, June 239:30 A.M.

(1) "Trimetric Projection" - Professor John E. Senne, Washington Univ.

(2) "Engineering Drawing in the Atomic Engineering Field" - Professor Eugene H. Brock, A & M College of Texas.

12:00 P.M.

Engineering Drawing Division Luncheon (joint with Architectural Engineering Division).

Speaker: Dean N. W. Dougherty, University of Tennessee

Topic: "ECPD Inspection Procedures and Results".

Business Meeting.

Wednesday, June 242:00 P.M.

(1) "Where Shall We Draw The Line" - Mr. Soderquist, Boeing Airplane Co.

(2) "The Role of Graphics in Engineering Education" - Professor Frank A. Heacock, Princeton University.

6:00 P.M.

Engineering Drawing Division Dinner.

REPORT OF THE BIBLIOGRAPHY COMMITTEE

by

Professor H. E. Fenwick, Chairman
University of Louisville

NEW AND REVISED BOOKS

<u>Author</u>	<u>Title</u>	<u>Ed.</u>	<u>Publisher</u>	<u>Year</u>	<u>Pages</u>	<u>Price</u>
Bishop, C.C.	Electrical Drafting and Design	3	McGraw-Hill	1952	--	\$4.50
French, T.E. & Vierck, C.J.	Manual of Engineering Drawing for Students and Draftsmen	8	McGraw-Hill	1953	715	6.00
Giesecke, Mitchell & Spencer	Technical Drawing	3	MacMillan Co.	1952	851	5.00
Giesecke, Mitchell & Spencer	Lettering Exercises	Rev.	MacMillan Co.		16 sheets	1.00
Grant, H.E.	Practical Descriptive Geometry	1	McGraw-Hill	1952	253	4.00
Heine, G.M.	How to Read Electrical Blueprints	1	Am. Technical Co.		318	3.00
Hoelscher, R.P., Arnold, J.N. & Pierce, S.H.	Graphic Aids in Engineering Computation	1	McGraw-Hill	1952	197	4.50
Hoelscher, R.P. & Springer, C.H.	Industrial Production Illustration	11	Pitman Pub. Co.	1952	243	5.75

<u>Author</u>	<u>Title</u>	<u>Ed.</u>	<u>Publisher</u>	<u>Year</u>	<u>Pages</u>	<u>Price</u>
Hove, H.B.	Descriptive Geometry	1	Ronald Press	1952	332	\$4.25
Luzadder, V.J.	Fundamentals of Engineering Drawing	3	Prentice Hall	1952	729	5.75
Johnson, L.H.	Nomography and Empirical Equations	1	John Wiley and Son	1952	150	3.75
Martin, C.L.	Architectural Graphics	1	MacMillan Co.	1952	224	4.00
Pare', Eugene, Loving, Robert Hill, Ivan	Descriptive Geometry	1	MacMillan Co.	1952	310	4.00
Porsch, J.H., Elrod, S.B., Hammond, R.H.	Problems in Engineering Graphics and Descriptive Geometry	1	Balt Publishers Southworth's Ext. Ser., W.Lafayette, Indiana	1952	90 prob. sheets	3.00
Rule, J.T. & Watts, E.F.	Engineering Graphics	1	Pitean Pub. Co.	1952	298	3.75
Rule, J.T. & Watts, E.F.	Engineering Graphics Workbook	1	Pitean Pub. Co.			4.00
Taylor, H.H.	Dictionary of Architecture	1	John Wiley & Sons	1952	221	4.50
Turner, W.V.	Shades and Shadows	1	Ronald Press	1952	122	

MAGAZINE ARTICLES

<u>Author</u>	<u>Title</u>	<u>Magazine</u>	<u>Vol.</u>	<u>Page</u>	<u>Date</u>
Adams, G.C.	Basic Engineering Standards and Their Place in Design	Engineering	173	380-1	Mar. 1952
Aitchison, A.	Eight Steps to Take Before you Make a Move	Ind. Marketing	37	201	June 1952
Barrow, G.	How to Specify Precision Knurls	Pro. Eng.	23	142-3	May 1952
	Better Film Views with Plastics	Mod. Plastics	29	81-3	June 1952
Bradley, A.L.	Product Drawings as Training Aids	S.A.E.J.	60	21-3	July 1952
Freedson, J.	Constructing Arcs Tangent to Circles	Mach.	58	204-5	June 1952
Fuller, R.B.	Slides and Filus; Multi-purpose Tools for Meetings (Part 2)	Sales Management	68	12-14	April 1952
Gillingham, T.E.	Better Ways to Prepare File and Index Mine Maps and Drawings	Eng. and Mining J.	153	89-93	May 1952
Harper, J. & Casady, M.E.	Templates of Detail Profiles Promote Drafting Efficiency	Product Eng.	23	178-80	Nov. 1952
Helmke, E.C.	Practical Dimensioning	Mach. Design	24	172-4	Feb. 1952
Lane, J.F.	Engineering Perspective Drawings	Mach. Design	25	106-11	Jan. 1953
Lee, C.A.	Avoid Blue Print Trouble When Adding New Equipment	Chem. Eng.	53	176-7	April 1952
	Lighting A Drafting Room	Eng.	47	647-8	Dec. 1952
	New Standard Consolidates Bolt and Nut Dimensions	Mach. Design	24	129-30	July 1952
	Objectives in Industrial Design	Product Eng.	23	171-8	April 1952
Patton, W.G.	Plastic Prototypes, Perspective Drawings, Special New Product Production	Iron Age	170	155-8	Sept. 1952
Rhoden, M.	Simple Way to Draw Nomographs	Chem. Eng.	59	146-7	Nov. 1952
Sanderson, A.E.	Infinite Sphere	J. Eng. Educ.	42	402-5	April 1952
	Stereo Photography Is Back in Style	BSNS W.		72	July 1952
Swain, P.	Easy Sketching System	Power	96	156-140	Sept. Oct. 1952
	Template Drafting; Reliance Elec. and Manufacturing Co.	Mach. Design	24	109	July 1952
Teuscher, F.L.	Templates Photography Low Cost Drawings	Product Eng.	23	186-90	May 1952
Thuring, G.L.	How to Get Faster, Better, Less Expensive Plant Layout Drawings Without Drafting	Factory Management	110	88-9	Oct. 1952
Varnum, E.C.	Circular Nomograms, Theory and Construction Technique	Product Eng. Edbk. p-		F28-30	1953
Wrather, V.E.	National Topographic Mapping	AM Soc. C.E.Proc.	77	1-6	April 1951

Prentice-Hall
COLLEGE TEXTS

Completely Revised and Up-to-Date!

FUNDAMENTALS OF ENGINEERING DRAWING

Third Edition

by Warren J. Luzadder, Purdue University

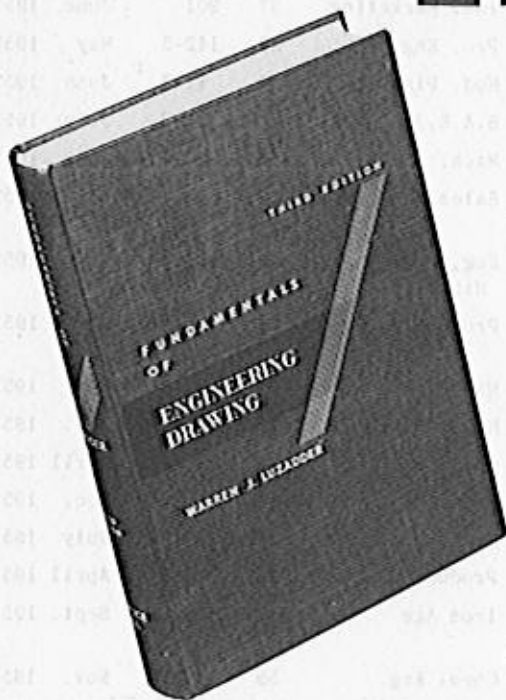

HERE is a truly up-to-date text with tables, problems and illustrations based on the new British-American Unified Screw Thread.

You will find this book is written so that you can spend your time teaching fundamental principles instead of answering scores of questions on details. Professor Luzadder constantly keeps in mind the students and the questions they usually ask. Consequently, students are always able to find an understandable illustration with a simple explanation for any difficult detail they may encounter.

HIGHLIGHTS OF THE NEW EDITION

- Many more new assembly drawings from which students may make drawings of individual parts.
- Shaded pictorial drawings present the rotated parts of the mechanism. Students working problems designed about these drawings must do some reasoning to produce a correctly finished work.
- All new "part" problems show adjacent parts so students can understand the function of the assigned part in a mechanism. For students the problem has much more significance and the part is not an unrecognizable piece.
- Brand new chapters on Architectural Drawing (chapter 23) and Graphical Calculus (chapter 29).
- Expanded coverage of Engineering Geometry, Dimensioning, Auxiliary Views, and Structural Drawing.
- Many new and practical problems — particularly in the chapter on Working Drawings (chapter 19).
- Students use the new drafting standards of the American Standards Association, plus the existing standards of the Association and The Society of Automotive Engineers.

721 pages 6" x 9"

PROBLEMS IN ENGINEERING DRAWING

3rd Edition

These 71 up-to-date worksheets were designed as a companion to the text. They are, however, adaptable to any standard text on engineering drawing and offer valuable follow-through to regular text work. The problems are in the form of partial layouts on manila-type drafting, graph, and regular bond paper. The sheets are loose, inserted in a heavy envelope with a booklet of instructions, and punched for keeping in a binder.

Announcing - **ELEMENTS OF DESCRIPTIVE GEOMETRY**

Part I — Text;
Part II — Problems

by Lewis O. Johnson and
Irwin Wladaver, New York University

Here is a brand new, up-to-date combination of text and workbook for a basic course in descriptive geometry. It is a combination that covers the fundamentals which should be part of the stock in trade of every beginning engineer.

The new Johnson and Wladaver stresses underlying principles . . . familiarizes the student with the equipment he will need to understand and interpret what he sees on a blueprint. It offers the future engineer the basic material to help him direct the work of others and help himself put his own ideas into tangible form.

ELEMENTS OF DESCRIPTIVE GEOMETRY has been especially prepared for use in departments where the amount of time allotted to descriptive geometry has been reduced.

Text—74 pages 8½ x 11 Illustrated
Problems—71 pages 8½ x 11

For approval copies write



PRENTICE-HALL, Inc. 70 FIFTH AVENUE, NEW YORK 11, N.Y.

GEOMETRIC CONSTRUCTIONS

by

Frederick E. Glesecke, Ph. D.
Formerly, Professor of Drawing
Texas A & M College

To draw a cylindrical helix with the aid of tangents.

A helix can be defined as the line traced on the surface of a circular cylinder by a point moving at a uniform rate along and around the cylinder; or as the line traced on the surface of a circular cylinder by a point moving so that the line intersects every element of the cylinder at the same angle; or as the shortest line which can be drawn on the surface of a circular cylinder connecting two points on the surface of the cylinder but not on the same element.

Basing the drawing on the first definition, the surface of the cylinder can be divided longitudinally and circumferentially into any number of equal parts, 12 for example, and the desired helix drawn by connecting the resulting 13 points of intersection of the dividing lines by a curved line, as shown in Fig. 2(a) and (b).

However, greater accuracy can be secured if the draftsman is guided by straight-line tangents at the several points of the helix and, in addition, by circular-arc tangents at the vertexes of the helix.

To find the projection of any one of the 13 straight-line tangents, draw the double circular cone, Fig. 2(c), whose axis coincides with the axis of the cylinder and whose elements make the same angle with a plane perpendicular to the axis as do the helix and its straight-line tangents, namely, the angle whose tangent is the lead of the helix divided by the circumference of the cylinder, or $L/2\pi R$. Since the diameter of the base of the double cone is $2R$, its altitude is $2R L/2\pi R$ or L/π . The reason for drawing the double cone instead of only the lower single cone is that the directions of the tangents can be determined more accurately because the elements of the double cone are twice as long as those of the lower single cone. Every element of this cone is parallel to two tangents at the helix in each turn or convolution of the helix.

To simplify the construction, the top view of the cylinder, Fig. 2(a), is used also as the top view of the cone; in this double use, the top view represents twelve elements of the cylinder, namely 1, 2, 3, 4, 5, 6, 7, 8, 9, 10, 11, and 12; and also seven elements of the double cone, namely 1-7, 2-8, 3-9, 4-10, 5-11, 6-12, and 7-13.

Having drawn the cone, to find, for example, the tangent at the point 6, conceive two planes to be drawn, one tangent to the cylinder at the point 6 whose top view would be the line HT, and a second plane through the axis of the cone and parallel to the first plane. The second plane would intersect the surface of the cone in two elements shown in the top view by the line 3-9 and in the front view by the lines 3-9 and 5-11. The line 3-9 is parallel to the tangent lines at the points 6 and 2 and

the line 5-11 is parallel to the tangents at the points 8 and 12.

These four tangents can then be drawn parallel to the respective elements of the cone.

The tangents at the points 3, 5, 9, and 11 can be found in a similar way by conceiving a plane to be drawn through the axis of the cone and parallel to the plane which is tangent to the cylinder either at the points 3 and 9 or 5 and 11.

The tangents at the points 4 and 10 are parallel, respectively, to the extreme left and the extreme right element of the lower cone.

The tangents at the points 1 and 13 are parallel to the central rear element of the lower cone; the tangent at the point 7 is parallel to the central front element of the lower cone.

To find the circular-arc tangent at a vertex of the helix, for example at vertex 7, Fig. 2(b), conceive a plane to be passed through the diameter of the cylinder at vertex 7 and oblique to the axis of the cylinder; the plane would intersect the cylinder in an ellipse the front view of which would be an ellipse except when the secant plane makes an angle of 45 deg. with the axis of the cylinder, in which case the front view of the ellipse would be a circle, a special case of the ellipse.

An infinite number of ellipses can be secure in this way; three of them are shown. Every one of the infinite number of possible ellipses would be tangent to the helix at the point 7 but the degree or the order of their tangency would vary with the angle which the plane of the ellipse makes with the axis of the cylinder. The ellipse which has the highest order of tangency with the helix is the one whose plane contains the straight-line tangent at the point 7; it is the middle one of the three ellipses shown; its minor axis is L/π as shown indirectly in Fig. 2(d).

The osculating circle of this ellipse at the point 7 is also the osculating circle of the helix at the point 7. The center of the osculating circle can be found graphically as explained on page 29 of the November 1952 issue of The Journal of Engineering Drawing.

To use the graphical method of finding the center of the osculating circle, it is necessary to know the length of the minor axis of the ellipse; this length is equal to the diameter of the cylinder times the tangent of the angle made by the straight-line tangent at the point 7 with a plane perpendicular to the axis of the cylinder;

i. e., it is $2R \times \frac{L}{2\pi R}$ or $\frac{L}{\pi}$ as shown in Fig. 2(d).

Instead of using the graphical method, the radius of

the osculating circle can be calculated as indicated for vertex 4 in Fig. 2(d).

The radius of the osculating circle can be calculated since it is equal to $\frac{b^2}{a}$ where b and a are, respectively, the semi-minor and the semi-major axis of the ellipse; hence the radius is $\frac{L^2}{4r^2R} = \frac{L^2}{39.48R}$ or approximately, but with sufficient accuracy, $\frac{L^2}{40R}$.

The circular-arc tangents can then be drawn at the vertexes 1, 7, and 13.

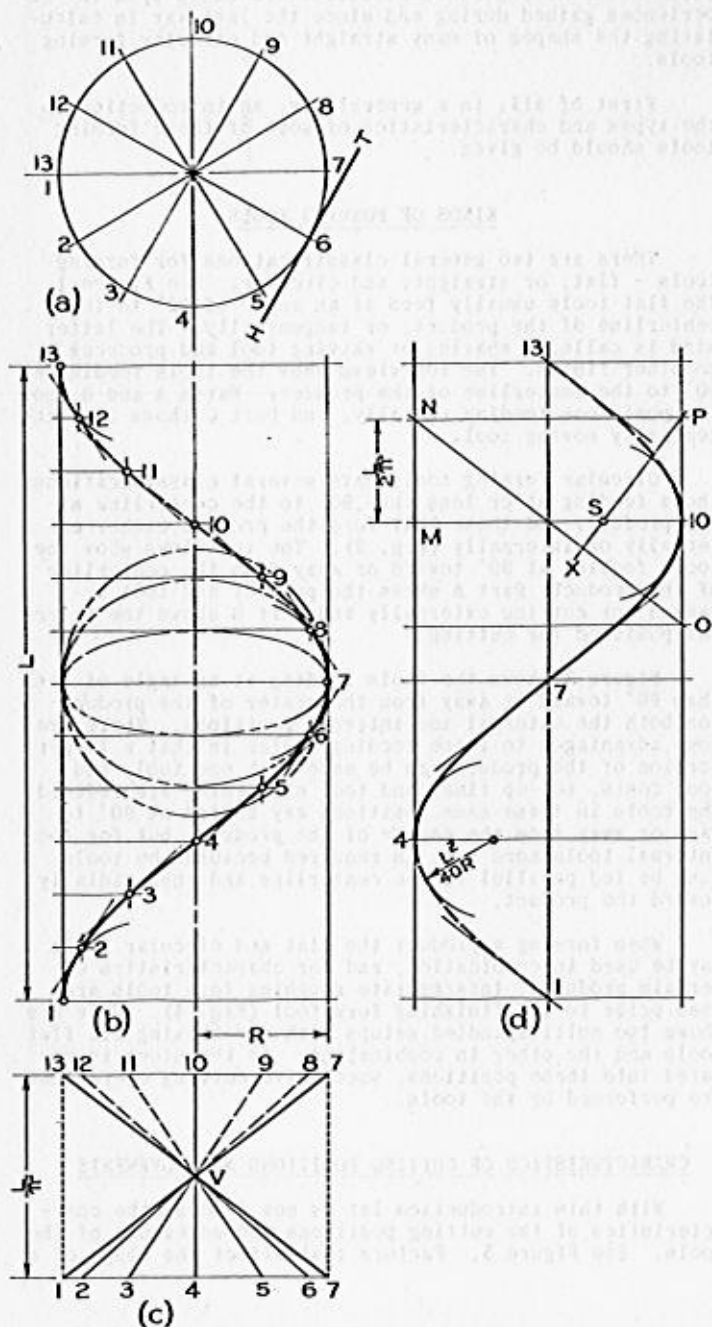

Fig. 2

In practice it is generally sufficiently accurate to draw the osculating circles at the vertexes and only the two straight-line tangents which are parallel to the plane of projection, as shown in the side view, Fig. 2(d), and to connect these tangents by the aid of irregular curves of suitable form. In the side view the center of the osculating circle was found by drawing the axis of the osculating ellipse M - 10 and setting off the semi-minor axis from M to N and then by drawing first; the diagonal of the rectangle circumscribed about the osculating ellipse, N - O; second, the upper side of the rectangle N - P; and third, the line P - X from P perpendicular to the diagonal N - O to intersect the diameter of the ellipse in the point S, the required center of the osculating circle of the ellipse and of the helix.

A WORD ABOUT UNIT TESTS IN ENGINEERING DRAWING

The direct sale of the UTEG materials has been discontinued for some time. However, because a number of individuals have indicated an interest in these tests, Educational Testing Service is attempting to keep them available by adopting the following plan.

1. "Kits" of the UTEG materials will be prepared and sold to colleges and industrial concerns that are interested in using the tests. These kits will authorize and make possible the reproduction of any one or all of the 16 tests, answer sheets and accessory materials for use solely by the purchaser within his organization.
2. Each "kit" will contain the following:
 - (a) 2 copies of each of the 16 unit test booklets.
 - (b) 2 copies of each of the 16 answer sheets.
 - (c) 2 directions for administering the tests.
 - (d) 2 instruction sheets for reproducing any or all of the materials.
 - (e) 2 copies each of the 16 scoring stencils.
 - (f) Copies of UTEG Report of Score Distributions.
3. Purchasers will agree not to reprint any of the above for resale, and will be asked to return to ETS two copies of the UTEG Report of Score Distributions (f) after each administration. Depending upon the apparent usefulness of the returned score distributions for the purpose of preparing suitable norms, later arrangements would be made for meeting the cost of developing those norms.
4. Each "kit" will cost \$20, and will be available to users about March 1, 1953.
5. Sample sets of the "kits" are not available.

While Educational Testing Service was reluctant to discontinue the direct sale of UTEG answer sheets, question sheets, etc., the small demand and rising handling costs necessitated this action. The above plan, however, is a sincere effort to keep these excellent tests available to interested individuals.

Warren Allen Rhule
Administrative Assistant
to Dr. A. F. Johnson

FORMING TOOL CALCULATIONS — GRAPHIC AND ALGEBRAIC

by

Professor J. H. Porsch

Department of General Engineering
Purdue UniversityINTRODUCTION

The term "forming tools" is applied to a wide variety of tools or machines that shape a product to some predetermined form. Illustrative of these and the fields in which they are used are the skin and hull forming machines for aircraft and ships, shaper knives in woodworking, stamping and die-casting machines, and forming rolls and extrusion dies in metal and plastics. Others in the metal-cutting industry include hobs, milling cutters, and screw-machine tools. The scope of this paper is limited to those cutting tools used in screw-machines, yet application to other similar tools and uses may be apparent.

Some tools are shaped precisely to form a product, and their contours are usually calculated. Others are less precise, and cut-and-try or just pure guessing methods are used in shaping the tool. A search through the many published articles on this subject reveals two observations of significant interest. First, the determination of the shapes of tools to form a product to a given profile is both difficult and tedious. This is indicated by the numerous articles on the cut-and-try methods, conversion tables, nomograms, and by the comments of the authors writing on these as well as other methods. The following quotations from several articles are typical. From Mr. Fritz L. Keller in his article in *Machinery*, November 1947 - "Many toolmakers and designers consider it difficult to calculate the developing angles to which a circular forming tool should be ground to produce given cutting angles." From Mr. Theodore Yeber, Jr., then Chief Design Engineer with the Palisade Engineering Company in his article in *The Tool Engineer*, May 1946 - "Calculating the diameters of circular form cutters, to correct for both top rake and offset, is ordinarily a time-consuming operation involving the solution of two oblique triangles. Not only are the calculations quite involved, but the degree of accuracy is such that the slide rule is out of the question, and the operator must resort to a calculating machine or six place logarithmic tables." And from Mr. O. A. Johnson, then Chief Tool Designer for Tyson Roller Bearing Corporation in his exhaustive articles in the *American Machinist*, 1932 - "One of the most perplexing, tedious problems that confronts a tool designer is the design of forming tools."

The second significant observation is that few articles attack the problem graphically; more are devoted to the toolmakers methods, while the greatest number is devoted to various mathematical approaches, including conversion tables and nomograms. The dearth of articles on the graphical approach may be due to the feeling that the method is inadequate or impractical, as expressed by Mr. Johnson in his further opinion as follows: "Some have tried to solve the problem by the projection method, laying out the tool in actual cutting position. This method requires a skilled engineer, and the layout would have to be several times actual size in order to give sufficient accuracy for tools for tapered roller bearing parts or similar precision jobs. In some cases, it would be impossible to do this."

The revealing and perhaps disappointing observation is that designers and engineers have forsaken their tools-in-trade, namely, the straightedge, triangle, scale, etc., for the just-as-important, but sometimes more unwieldy, tool, mathematics. The failure to use graphics obviously could not be criticized if it were unsuitable for the

problem. The facts are, however, that since screw-machine forming tools and products are usually small and permit reasonable tolerances, they are adaptable to a graphical solution in that the drawing can be enlarged to obtain an acceptable degree of accuracy.

It is intended at this time to show you some mathematical and graphical solutions to problems of this nature and to point out the desirability of the graphical method through the simple use of the common drafting tools. These observations and conclusions are based upon the experiences gained during and since the last war in calculating the shapes of many straight and circular forming tools.

First of all, in a general way, an introduction to the types and characteristics of some of these forming tools should be given.

KINDS OF FORMING TOOLS

There are two general classifications for forming tools - flat, or straight, and circular. See Figure 1. The flat tools usually feed at an angle of 90° to the centerline of the product, or tangentially. The latter kind is called a shaving or skiving tool and produces a smoother finish. The top views show the tools feeding at 90° to the centerline of the product. Parts A and B show two positions feeding radially, and Part C shows the tangentially moving tool.

Circular forming tools have several classifications: those feeding at or less than 90° to the centerline of the product; and those that form the product either externally or internally (Fig. 2). The top views show the tools feeding at 90° toward or away from the centerline of the product; Part A shows the product and tool arranged for cutting externally and Part B shows the internal position for cutting.

Figure 3 shows the tools feeding at an angle of less than 90° toward or away from the center of the product for both the external and internal positions. There are some advantages to these feeding angles in that a larger portion of the product can be made with one tool, and tool costs, set-up time, and tool sharpening are reduced. The tools in these same positions may be fed at 90° toward or away from the center of the product, but for the internal tools more time is required because the tools must be fed parallel to the centerline and then radially toward the product.

When forming a product the flat and circular tools may be used in combination, and for characteristics of certain products, intermediate roughing form tools are used prior to the finishing form tool (Fig. 4). Here are shown two multi-spindled setups with one showing all flat tools and the other in combination. As the stock is rotated into these positions, successive cutting operations are performed by the tools.

CHARACTERISTICS OF CUTTING POSITIONS AND MOVEMENTS

With this introduction let us now discuss the characteristics of the cutting positions and movements of the tools. See Figure 5. Factors that affect the shape of a

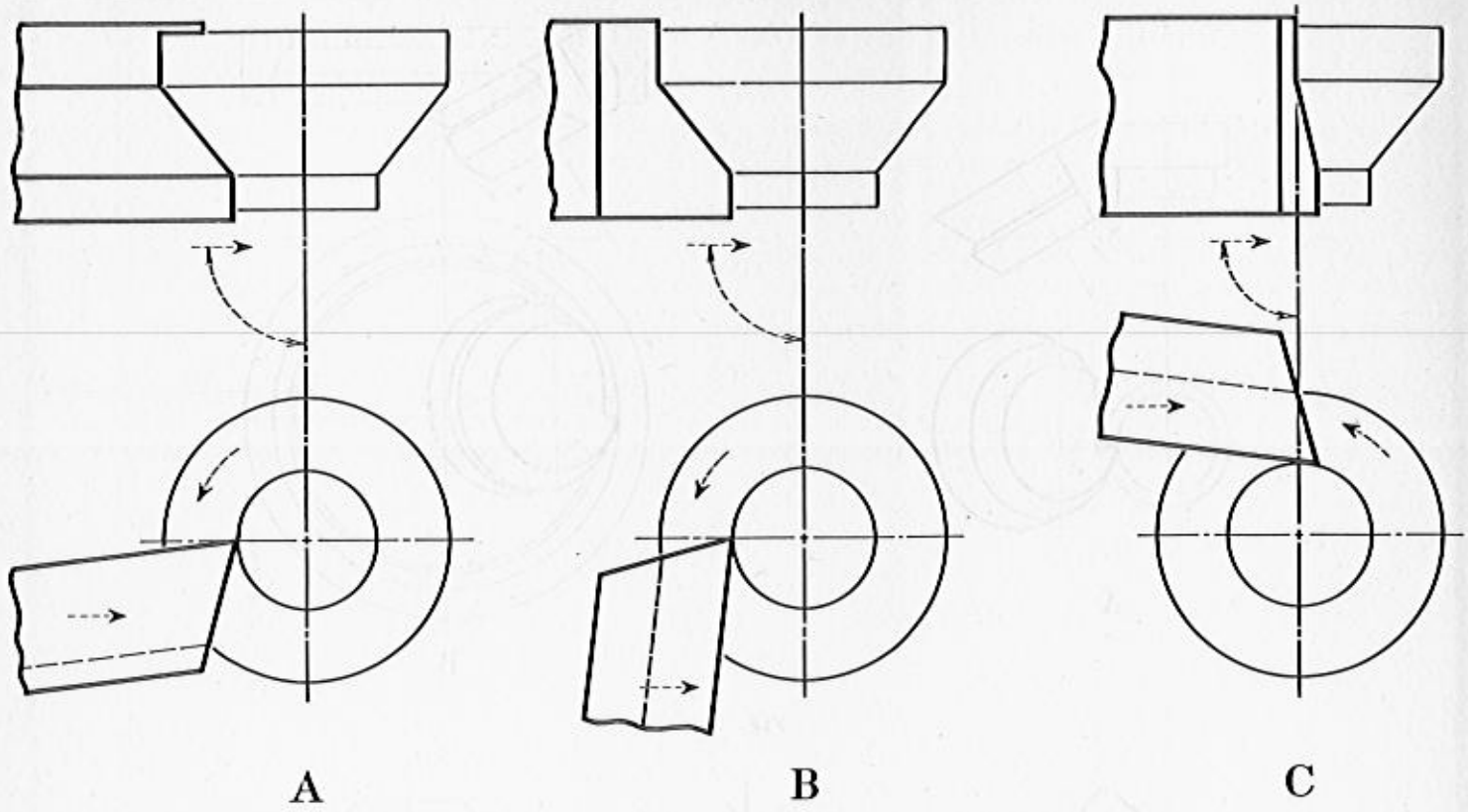

Fig. 1

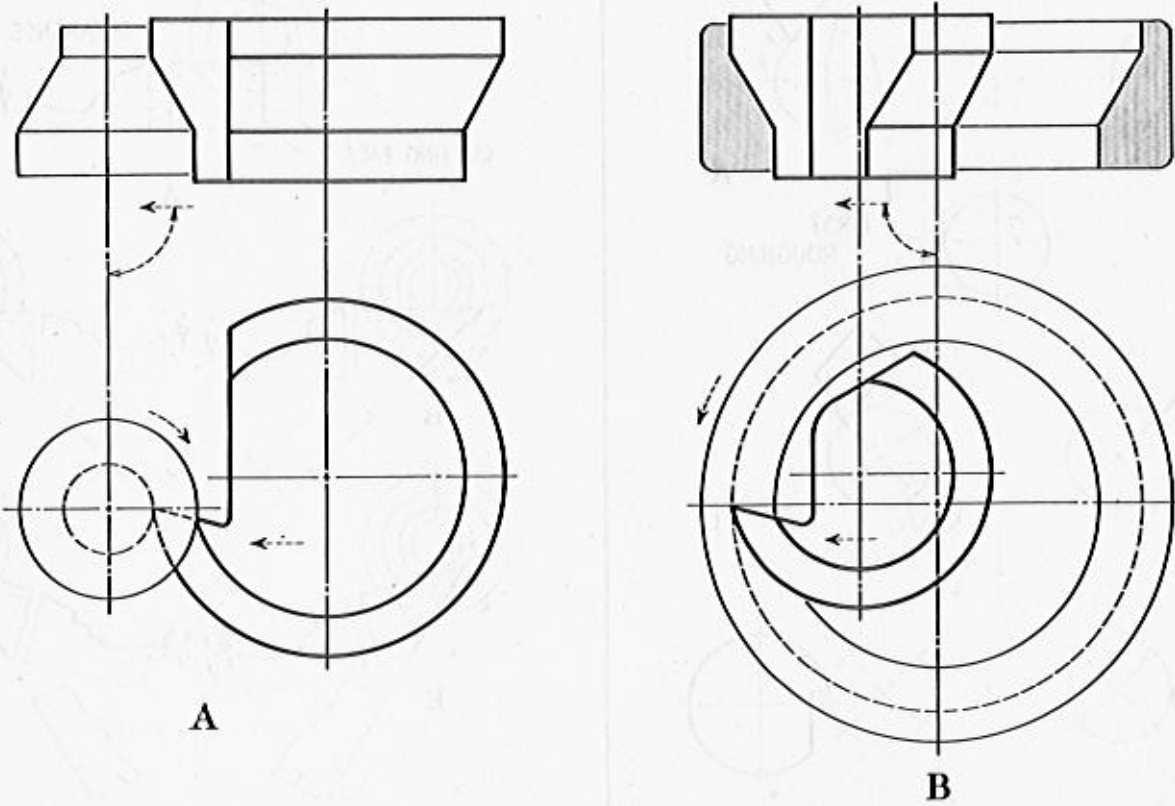

Fig. 2

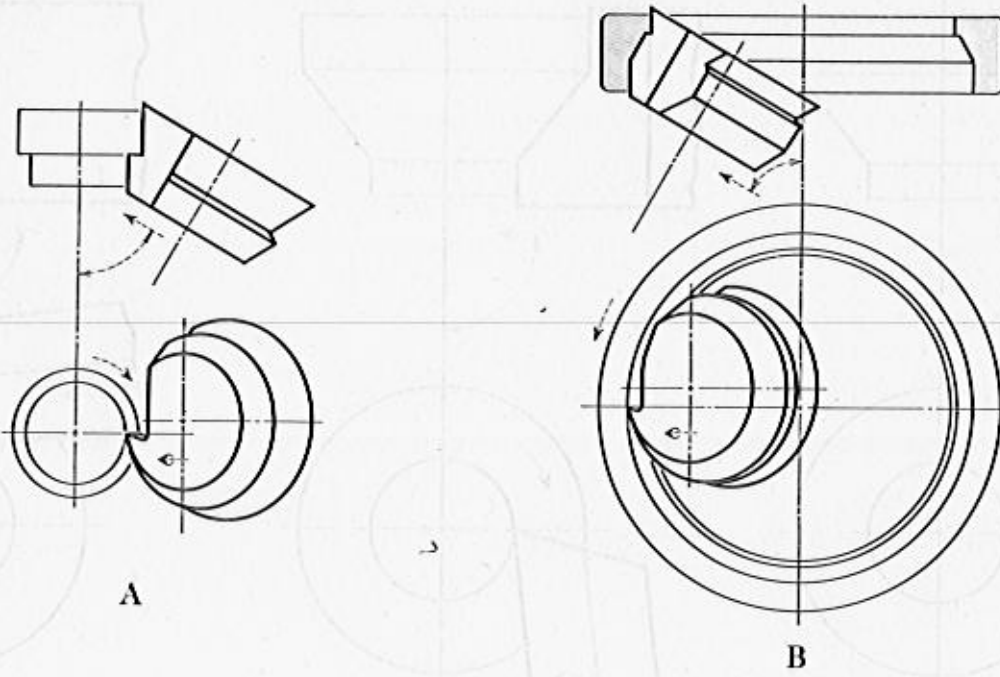

Fig. 3

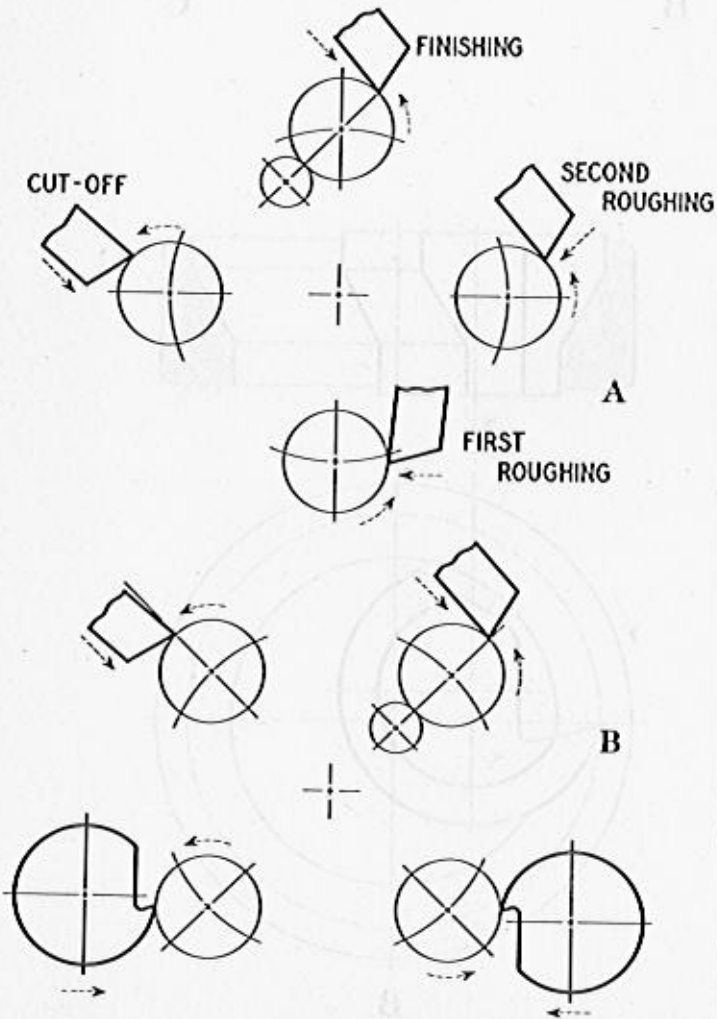

Fig. 4

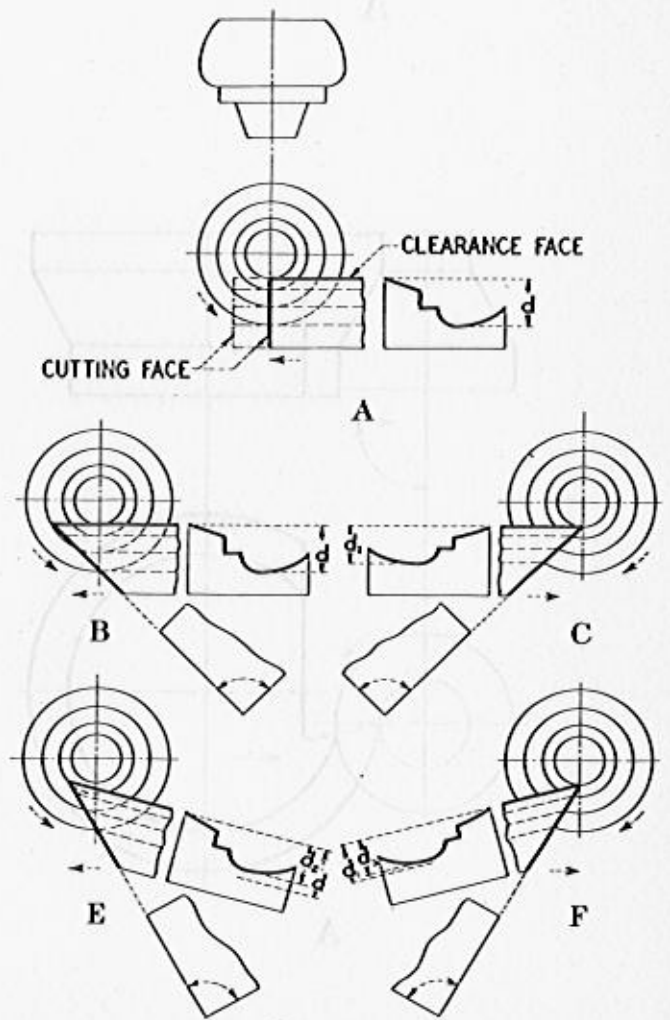

Fig. 5

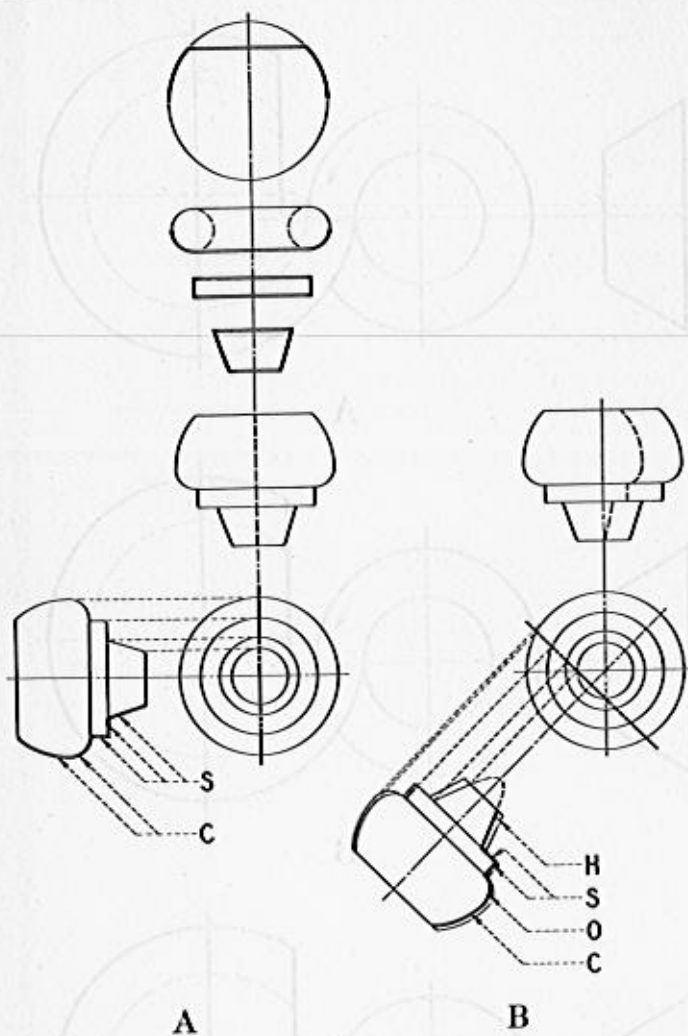

Fig. 6

forming tool are the positions, with respect to the product, of the two surfaces forming the cutting edge, and the stopping point of the tool either "at" or "past" the center of the product. The name associated with the angle of the cutting face is the "rake" angle, and that with the clearance face the "clearance" angle. If the cutting face is at an angle other than 90° to the sides of the tool, a "vise angle" is said to be introduced, and the tool has a "compound rake" angle. Here we see the effect of the positions of these surfaces on the shape of a tool. For ease in describing the following discussion has been confined to the flat tools, for, with few exceptions, it is applicable also to the circular tools. In Part A the tool has neither rake nor clearance angle and the cross-sectional shape of the tool is the same as the section of the product formed by a vertical plane passed to contain the axis of revolution. The depth (d) of the cutting portion of the tool is the same as the difference between the largest and smallest diameters of the product, and remains unchanged for the tool stopping at or passing the center of the product. In Part B a positive rake angle is introduced, but by reason of the tool progressing beyond the center of the product the depth and shape of the tool remain the same as in Part A. In Part C, with positive rake angle and zero clearance angle, the tool stops with its foremost cutting tip, which forms the smallest diameter on the product, at the center of the product. In this case the plane of the cutting face does not contain the axis of revolution of the product and the effect is to decrease the depth of the tool. Compare (d) and (d_1) in Parts B and C. In parts E and F clearance

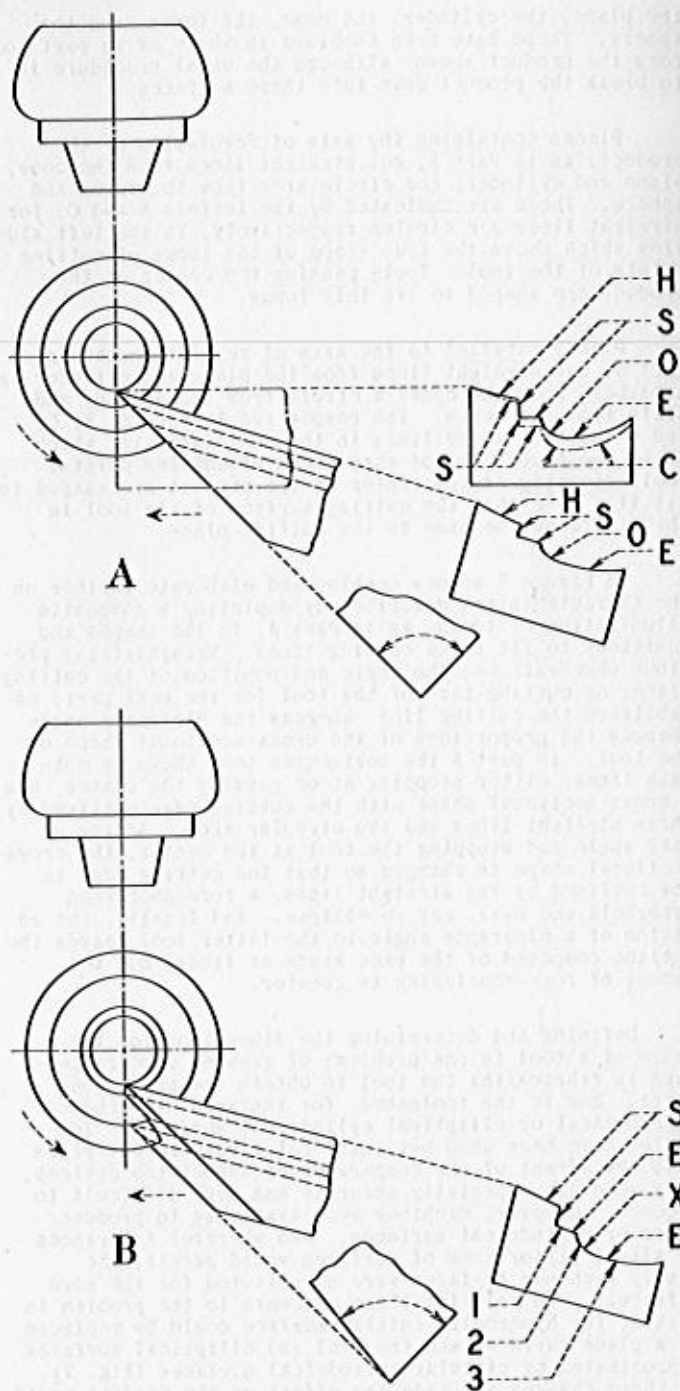

Fig. 7

angles other than zero are introduced and the effect is to decrease further the depth of the tool. Compare (d) with (d_2) in Part E, and (d_1) with (d_3) in Part F. We might summarize these observations by stating that the depth (d) of the total needed to form the difference between the largest and smallest diameters of the product is always decreased by the addition of a clearance angle, and usually decreased by the addition of a rake angle.

Our attention is now directed to the shape of the cutting edge, that is, to the kinds of lines that compose it. In so doing we should analyze the surfaces of revolution usually formed on a product (Fig. 6). They are

the plane, the cylinder, the cone, the torus, and the sphere. These have been combined in whole or in part to form the product shown, although the usual procedure is to break the product down into these surfaces.

Planes containing the axis of revolution of the product, as in Part A, cut straight lines from the cone, plane and cylinder, and circle arcs from the torus and sphere. These are indicated by the letters S and C, for straight lines and circles respectively, in the left side view which shows the true shape of the locus of cutting points of the tool. Tools passing the center of the product are shaped to fit this locus.

Planes parallel to the axis of revolution, as in Part B, cut straight lines from the plane and cylinder, a hyperbola from the cone, a circle from the sphere, and ovals from the torus. The respective letters S, R, C, and O indicate these lines in the auxiliary view which shows the true shape of this locus of cutting points. Tools stopping at the center of the product are shaped to fit it. Note that the cutting surface of the tool in this instance the same as the cutting plane.

In Figure 7 we now combine and elaborate further on the characteristics described by depicting a composite illustration of tools, as in Part A, in the shapes and positions to fit these cutting lines. Reemphasizing previous observations, the angle and position of the cutting plane, or cutting face of the tool for the most part, establishes the cutting line, whereas the clearance angle changes the proportions of the cross-sectional shape of the tool. In part A the horizontal tool shown by dot-dash lines, either stopping at or passing the center, has a cross-sectional shape with the cutting edge outlined by three straight lines and two circular arcs. Adding a rake angle and stopping the tool at the center, the cross-sectional shape is changed so that the cutting edge is now outlined by two straight lines, a fore-shortened hyperbola and oval, and an ellipse. And finally, the addition of a clearance angle to the latter tool leaves the outline composed of the same kinds of lines, but the amount of fore-shortening is greater.

Defining and determining the dimensions for the shape of a tool is one problem; of greater concern perhaps is fabricating the tool to obtain the prescribed shape. How is the toolmaker, for instance, to produce hyperbolic or elliptical cylindrical surfaces? Templates have been used but until relatively recent years with the advent of the comparator or associated devices, they were not especially accurate and were difficult to produce. However, machines were available to produce plane or cylindrical surfaces. And wherever tolerances or slight distortions of surfaces would permit, the easily machined surfaces were substituted for the more difficult. In relating these comments to the problem in Part A, the hyperbolic cutting surface could be replaced by a plane surface, and the oval and elliptical surfaces approximated by circular cylindrical surfaces (Fig. 7). If these changes are made the effect on the product would be to make the conical surface "dished," or in more academic terms, a hyperboloid of revolution. If a true cone is necessary and the other surfaces approximate, a means for eliminating the "dish" is to introduce a compound angle as shown in Part B. The angle is selected so that the cutting edge to form the cone is a straight line element of the cone. In this event the cutting plane, now no longer parallel but oblique to the centerline of the product, cuts lines which project as ellipses for the cylinder and sphere, and "what-have-you" for the torus. And again, if these last surfaces need be only approximate, they may be replaced by plane and circular cylindrical surfaces. Illustrating, line 1 can be made straight, and lines 2 and 3 circular.

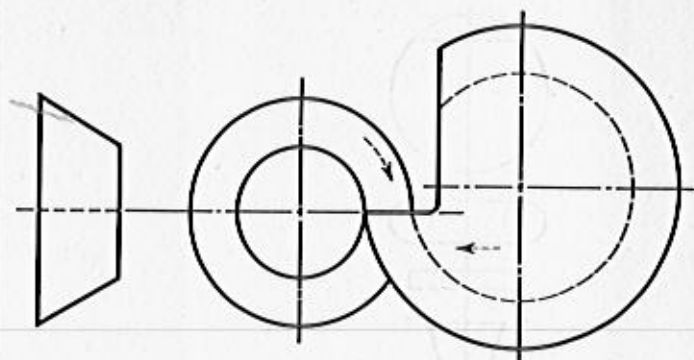

A

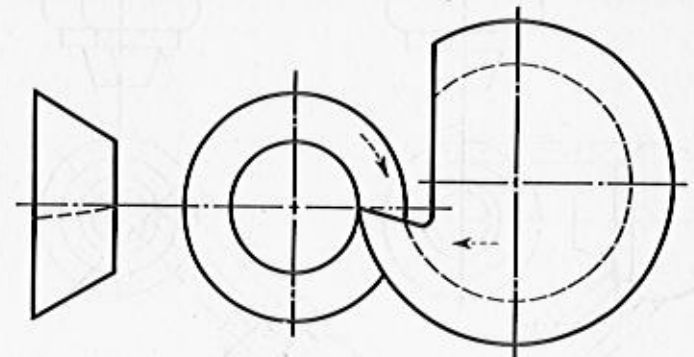

B

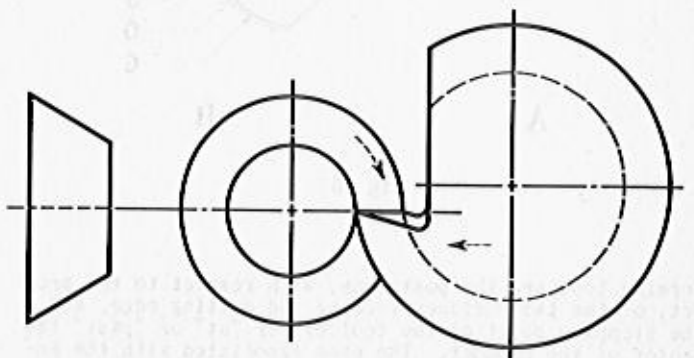

C

Fig. 8

Time does not permit a similar elaboration for the circular tools, but a few points should be mentioned and illustrated quickly (Fig. 8). Here are shown three tools with zero, positive, and compound rake angles, and their corresponding cutting edges on conically shaped products. Note that 1) the center of the tool is placed above the center of the product to provide clearance; 2) the cutting edge is on or below the center of the product; 3) the tool moves radially only; and 4) the plane of the cutting face of the tool again determines the cutting edge or cut section from the product. The faces of the tool therefore must be shaped to fit these cutting edges which are the same as for the flat tools under similar conditions.

KNOW YOUR COMMITTEES

by

J. Gerardi

Chairman, Division of Engineering Drawing
University of DetroitOFFICERS

Chairman: J. Gerardi, Univ. of Detroit, Detroit, Michigan

Vice-Chairman: R. T. Northrup, Wayne Univ., Detroit, Michigan

Secretary-Treasurer: J. G. McGuire, A & M College of Texas, College Station, Texas

Executive Committee: W. E. Street, A & M College of Texas (1 year)
C. E. Rowe, Univ. of Texas, Austin, Texas (2 years)
H. E. Grant, Washington Univ., St. Louis, Mo. (3 years)
J. S. Rising, Iowa State College, Ames, Iowa (4 years)
R. P. Hoelscher, Univ. of Illinois, Urbana, Ill. (5 years)

Publication Committee - Journal of Engineering Drawing:

W. J. Luzadder, Editor, Purdue Univ., Lafayette, Ind.
C. J. Vierck, Advertising Mgr., Ohio State Univ., Columbus, Ohio
E. Griswold, Circulation Mgr., The Cooper Union, New York, New York

Editor T-Square Page: John Russ, University of Iowa, Iowa City, Iowa

A.S.E.E. General Council Member:

R. S. Paffenbarger, Ohio State Univ., Columbus, Ohio

Special Awards Committee:

O. W. Potter, Chairman, Univ. of Minnesota, Minneapolis
C. H. Springer, Univ. of Illinois, Urbana, Illinois
R. S. Paffenbarger, Ohio State Univ., Columbus, Ohio

Advanced Graphics Committee:

F. A. Heacock, Chairman, Princeton Univ., Princeton, N. J.
J. T. Rule, Massachusetts Inst. of Tech., Cambridge, Mass.
J. N. Arnold, Purdue Univ., Lafayette, Ind.
J. G. McGuire, A & M College of Texas, College Station, Texas
A. S. Levens, Univ. of California, Berkeley, Calif.
C. H. Kearns, Jr., Ohio State Univ., Columbus, Ohio

Bibliography Committee:

H. H. Fenwick, Chairman, Univ. of Louisville, Louisville, Ky.
H. E. Grant, Washington Univ., St. Louis, Missouri
E. F. Tozer, Northeastern Univ., Boston, Mass.
J. N. Arnold, Purdue Univ., Lafayette, Indiana
C. H. Kearns, Jr., Ohio State Univ., Columbus, Ohio

Committee on Drawing Instruments and Materials:

J. H. Porsch, Chairman, Purdue Univ., Lafayette, Indiana
J. Gerardi, Univ. of Detroit, Detroit, Michigan
L. R. Schruben, Univ. of Southern Calif., Los Angeles, Calif.
R. O. Loving, Illinois Inst. of Tech., Chicago, Ill.
J. M. Russ, State Univ. of Iowa, Iowa City, Iowa
E. M. Griswold, The Cooper Union, New York, N. Y.
N. C. McGuire, Univ. of Texas, Austin, Texas
H. G. Kinner, Rennselaer Polytechnic Inst., Troy, N. Y.

Teaching Aids Committee:

H. B. Howe, Chairman, Rennselaer Poly. Inst., Troy, N. Y.
Justus Rising, Purdue Univ., Lafayette, Ind.
F. M. Warner, Univ. of Washington, Seattle, Wash.
J. G. McGuire, A & M College of Texas, College Station, Texas
L. G. Palmer, Univ. of Minnesota, Minneapolis, Minnesota
J. S. Rising, Iowa State College, Ames, Iowa

Policy Committee:

W. E. Street, Chairman, A & M College of Tex., College Station, Texas
R. P. Hoelscher, Univ. of Illinois, Urbana, Ill.
Justus Rising, Purdue Univ., Lafayette, Ind.

Election
Committee:

R. T. Northrup, Chairman, Wayne Univ., Detroit, Michigan
 H. K. Skanser, Michigan State Univ., Lansing, Michigan
 J. B. Rackway, Lawrence Inst. of Tech., Detroit, Michigan

Local Committee for June 1953 Annual Meeting:

G. O. Phelps, Univ. of Florida, Gainesville, Florida
 E. S. Frash, Univ. of Florida, Gainesville, Florida

Committee on Display of Student Work:

M. McNeary, Chairman, Univ. of Maine, Orono, Maine
 J. S. Dobrovlny, Univ. of Illinois, Urbana, Ill.
 L. E. Stark, A & M College of Texas, College Station, Texas
 S. E. Shapiro, Univ. of Illinois, Navy Pier, Chicago, Ill.
 G. O. Phelps, Univ. of Florida, Gainesville, Florida

Committee on Display of Instruments and Drawing Materials:

A. Jorgensen, Chairman, Univ. of Penna., Philadelphia, Pa.
 J. E. Pearson, Univ. of Illinois, Urbana, Ill.
 V. H. Taylor, Univ. of Alabama, Tuscaloosa, Ala.
 G. O. Phelps, Univ. of Florida, Gainesville, Fla.
 N. D. Thomas, Ohio University, Athens, Ohio
 E. S. Frash, Univ. of Florida, Gainesville, Fla.
 C. A. Newton, Univ. of Tennessee, Knoxville, Tenn.

JOURNAL OF ENGINEERING DRAWING

PUBLISHED IN THE INTEREST OF TEACHERS AND OTHERS
 INTERESTED IN ENGINEERING GRAPHICS

Annual Subscription Price, \$1.25

PUBLISHED IN FEBRUARY, MAY, AND NOVEMBER BY
 THE DIVISION OF ENGINEERING DRAWING AND DESCRIPTIVE GEOMETRY OF THE
 AMERICAN SOCIETY FOR ENGINEERING EDUCATION

PUBLICATION COMMITTEE

Warren J. Luzadder, Editor
 Purdue University
 WEST LAFAYETTE, INDIANA

Charles J. Vierck, Advertising
 The Ohio State University
 COLUMBUS, OHIO

Edward M. Griswold, Cir. & Treas.
 The Cooper Union
 NEW YORK, N. Y.



THERE ARE YEARS OF
UNHURRIED CRAFTSMANSHIP

behind every



quick

action bow

The latest in a long line of Riefler
firsts . . . the famous original Quick-Action
bow . . . was literally over a hundred years
in the making. Now completely proven on
multitudes of American drawing boards,
this convenient, accurate, precision bow is the result
of a progression of fine Riefler drawing instruments
begun in 1842, which has now reached a peak of perfection.

Again, American ingenuity combines with old-world
gemütlichkeit to bring you Riefler drawing instruments
. . . unsurpassed in quality, accuracy and precision.

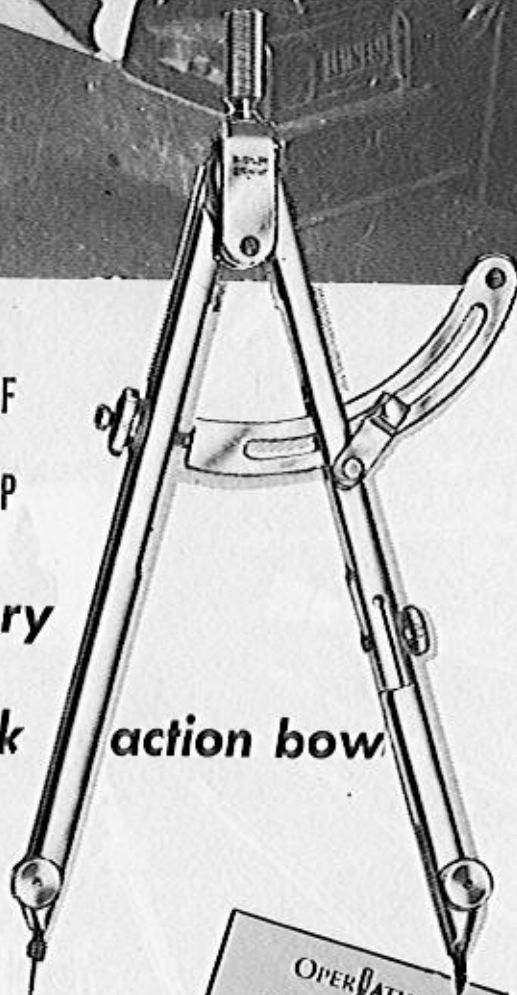

Want to know more
about Riefler precision
instruments? Then
send for your copy
of OPERATION
CRAFTSMANSHIP
today; the profusely
illustrated story of
German drawing
instruments

GRAMERCY IMPORT COMPANY, INC.

16 BEAVER STREET • NEW YORK 4, N. Y.

you can use **HIGGINS** INK
with more than **30** instruments

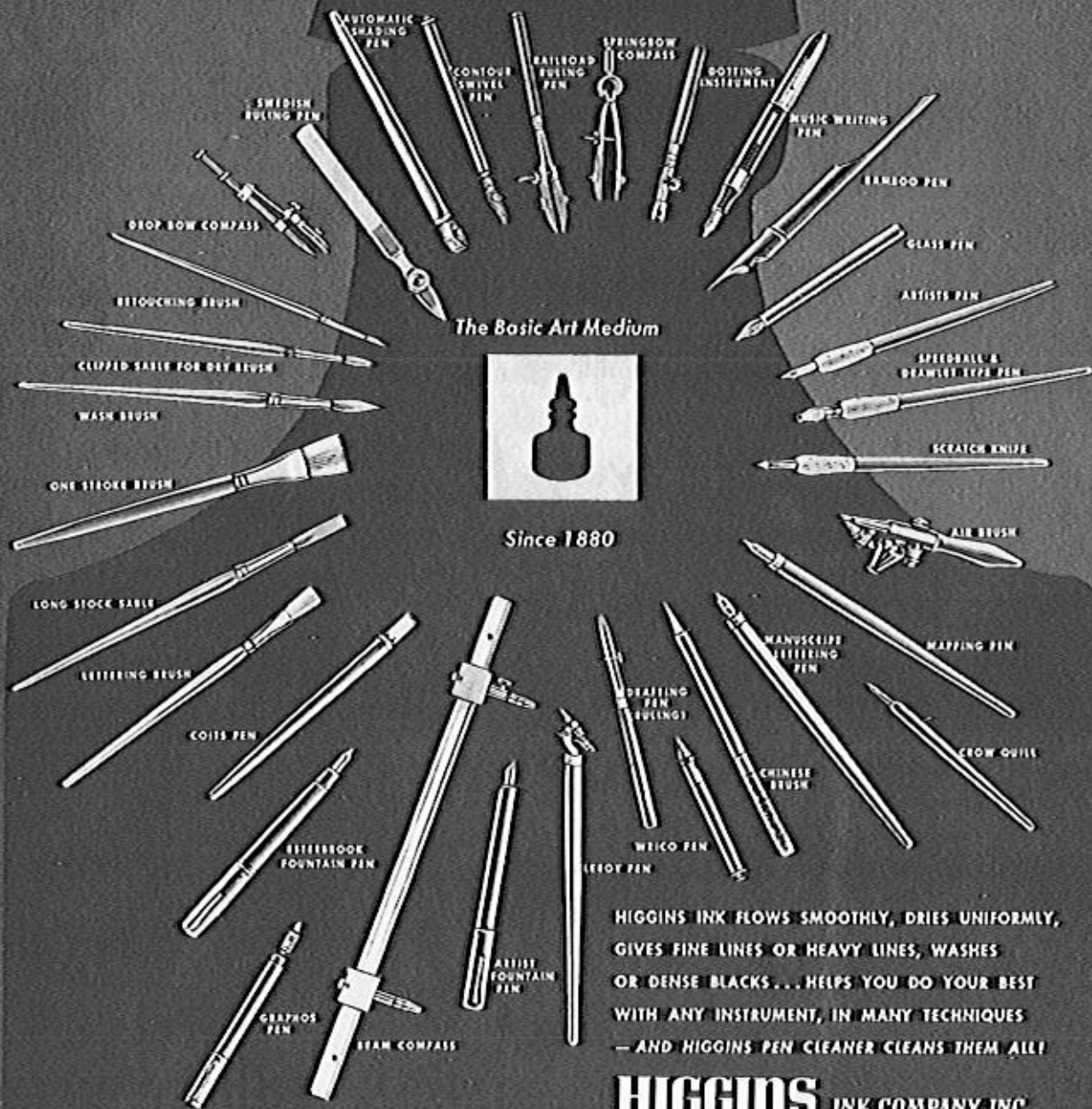

HIGGINS INK FLOWS SMOOTHLY, DRIES UNIFORMLY, GIVES FINE LINES OR HEAVY LINES, WASHES OR DENSE BLACKS... HELPS YOU DO YOUR BEST WITH ANY INSTRUMENT, IN MANY TECHNIQUES — AND HIGGINS PEN CLEANER CLEANS THEM ALL!

HIGGINS INK COMPANY, INC.
BROOKLYN, NEW YORK



WILD
HEERBRUGG

*Drawing instruments
of highest accuracy*

The leading Swiss manufacturer of precision instruments introduces an Instrument Set of outstanding merit. Drawing instruments of highest precision and of great accuracy in performance for the most exacting standards.

- Rustproof steel 5 times stronger than brass
- Improved straight guidance of the compass-head
- Maximum degree of precision is guaranteed
- Fine finish of the drawing pens
- A modern metal case, not an old-fashioned box.

ASK FOR BOOKLET RZ300e

HENRY WILD SURVEYING INSTRUMENTS SUPPLY CO.
OF AMERICA, INC.

26 COURT STREET, BROOKLYN 2, N. Y. • TRIangle 5-0644

Leaders
in finest quality
DRAWING INSTRUMENTS
since 1867

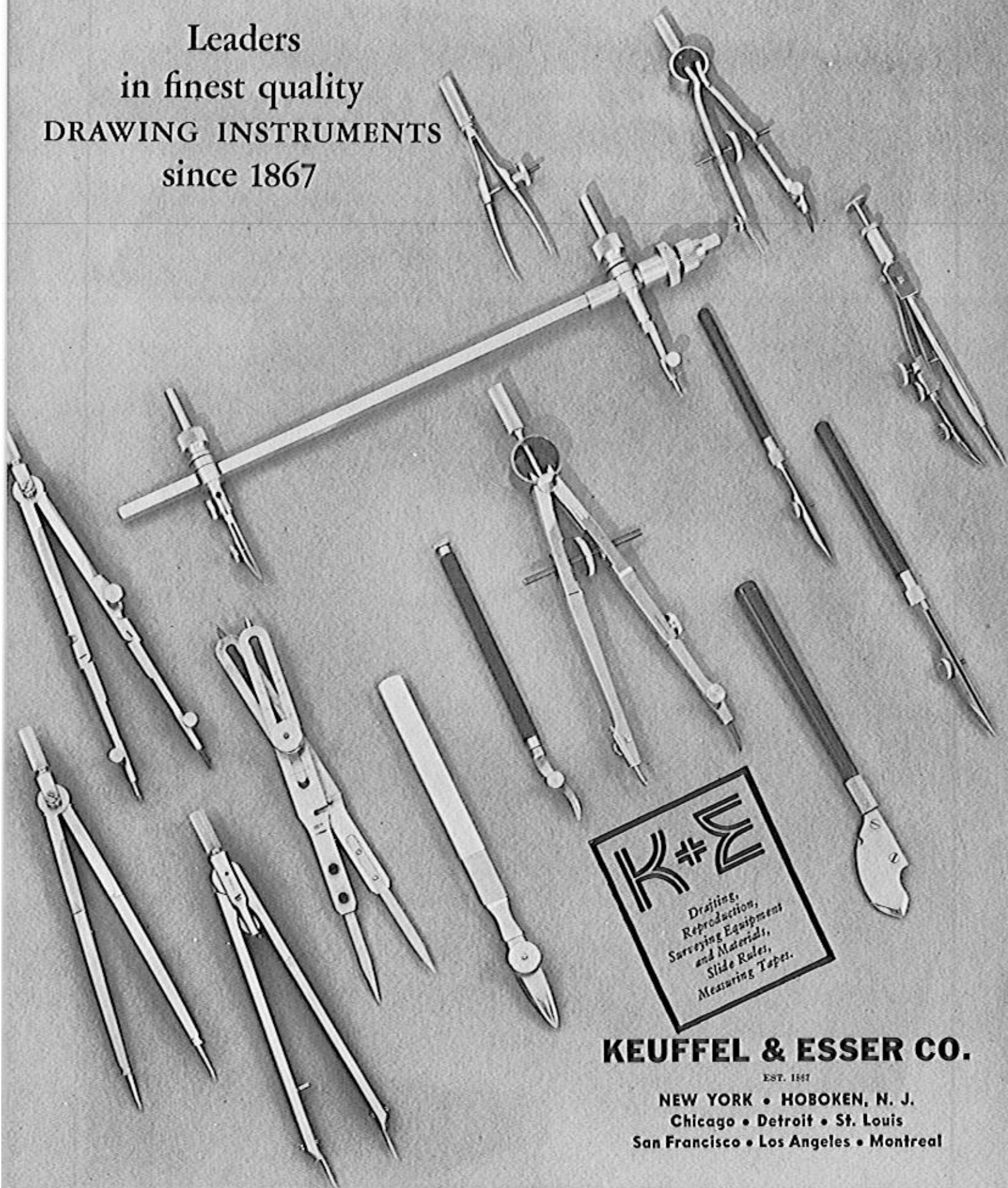

KEUFFEL & ESSER CO.

EST. 1867

NEW YORK • HOBOKEN, N. J.
Chicago • Detroit • St. Louis
San Francisco • Los Angeles • Montreal



Ready Now NEW 2ND EDITION

ROWE and McFARLAND'S
ENGINEERING DESCRIPTIVE GEOMETRY

By CHARLES ELMER ROWE and JAMES DORR McFARLAND

Both of the University of Texas

This NEW EDITION, now under the co-authorship of two educators who have worked together on Descriptive Geometry for over a quarter of a century, has in its problem section *virtually all new problems*, many of which are practical engineering applications. Over fifty per cent of them are shown in *layout form*. The "direct method" of Descriptive Geometry as emphasized in this text, has distinct advantages over the older of "Mongean method". Students show more interest in their work, learn a greater number of practical applications, and acquire a more usable understanding of the subject.

The *simple co-ordinate system* of the first edition has been retained as being the *easiest and most accurate method* of transferring the data to the student's drawing paper. The problem is thus located *properly* on the paper, allowing available space for its solution. The instructor will find the co-ordinate system a simple and *time-saving* method of presenting problem data for quizzes and examinations.

This important text develops the ability of the student to *think in space* by —

- the use of the direct method which solves problems directly from the data as given
- the treatment of fourteen principles concerning simple conceptions of relationships in space
- comprehensive instructions for determining the visibility of all edges or lines in any view of an object
- particular emphasis on orientation, the mental process by which the student relates himself to any view of an object in such a manner that the view appears to him as the actual object would appear for that particular direction of sight
- and the analysis of problems followed by basic drawing board constructions.

DESIGNED for freshman or sophomore students in the engineering curriculum. This text is arranged for a one semester course of 3 lecture hours and 6 laboratory hours per week.

CONTENTS OF NEW 2ND EDITION

I Introduction	VIII Warped Surfaces
II Principal Views	IX Geology and Mining Problems
III Auxiliary Views	X Engineering Problems
IV Oblique Views	XI The Mongean Method of Descriptive Geometry
V Line and Plane Problems	XII Shades and Shadows
VI Surfaces and Developments	XIII Perspective Drawings
VII Surfaces and Intersections	XIV Problems

352 pages — 6x9 — Illustrated — Cloth — \$4.25

WRITE TODAY FOR YOUR ON-APPROVAL COPY



BRADDOCK LETTERING ANGLES

DESIGNED FOR STUDENTS, ENGINEERS,
DRAFTSMEN AND ARCHITECTS

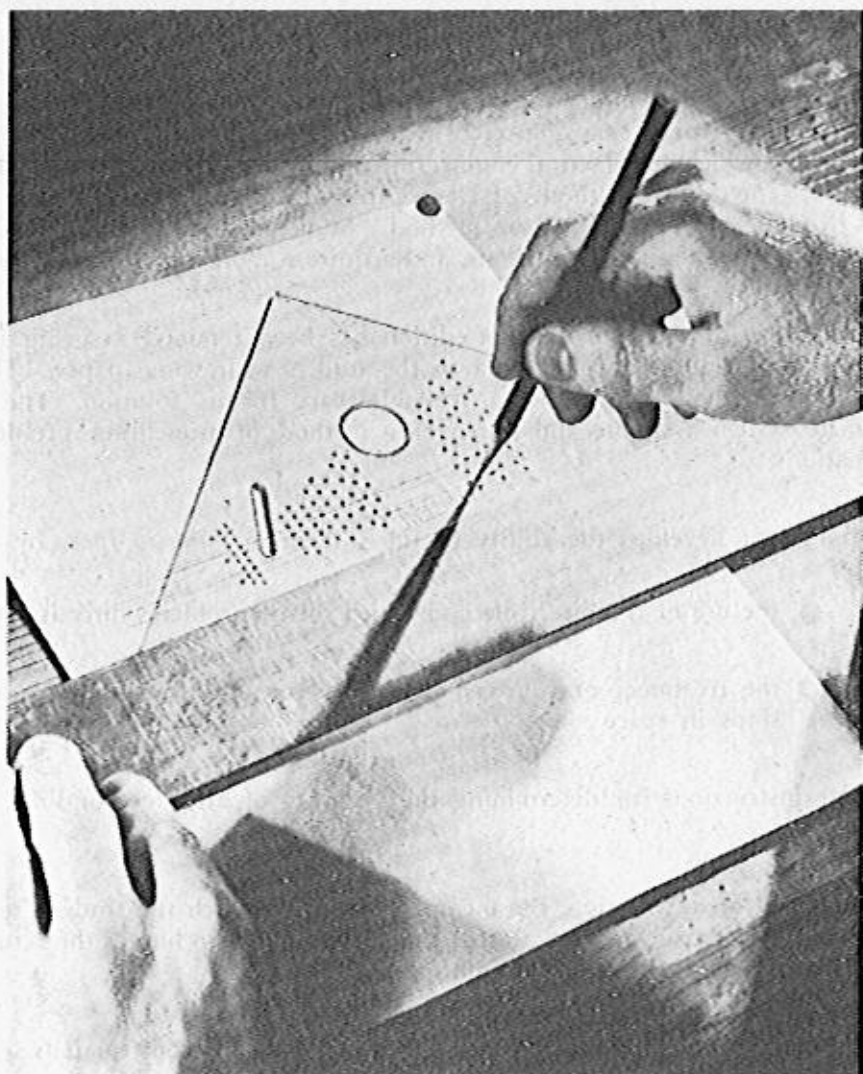

BRADDOCK ROWE LETTERING ANGLE

The special group of holes "S" on the BRADDOCK-ROWE LETTERING ANGLE was designed primarily to aid in teaching SYSTEMATIC DIMENSIONING by giving a QUICK and EASY method of properly locating dimensions and drawing guide lines for them. The special group of holes is located low in the left corner where they are most convenient to use. This instrument also serves as a 6-inch, 45 degree standard drafting triangle. It is made of dimensionally-stable VINYLITE, and is of exceptional accuracy.

Braddock Lettering Angles are available in twenty-two other sizes and styles in the 30-60 and 45 degree shapes. All are made of VINYLITE.

BRADDOCK INSTRUMENT COMPANY

PITTSBURGH 18, PA.

DESCRIPTIVE GEOMETRY

A Pictorial Approach

HAROLD BARTLETT HOWE

Rensselaer Polytechnic Institute

COMBINING the pictorial approach with the direct method, this up-to-date textbook provides a clear-cut way to present descriptive geometry. This approach stimulates student capacities to perceive and visualize; facilitates mastery of principles; and insures a broad coverage of the subject. Sketching ability is gradually built by progressing from fundamentals to more complicated combinations. Emphasizes vectors and their use in finding stresses in planar and non-coplanar structures and for the representation of moments. ". . . a remarkable piece of work . . . In a field already noteworthy for an amazing number of excellent, scholarly, and teachable textbooks, Professor Howe's is destined to take a foremost position."—Professor IRWIN WLADAVER, New York University.

328 ills., 332 pages, \$4.25

SHADES AND SHADOWS

Their Use in Architectural Rendering

WILLIAM WIRT TURNER

University of Notre Dame

A CONCISE modern textbook giving information for the correct determining of the shades and shadows of objects, particularly architectural compositions. Brief, self-explanatory discussions of all phases of shades and shadows stress the fundamentals, with one principle evolving naturally from the other. 12 supplementary work sheets provide exercises for maximum coverage in a minimum of time. All problems are based on those architectural elements recurring in professional practice. ". . . Turner, as usual, has done an excellent piece of work, for he has used the simple method of explanation . . . his fine illustrations show very clearly how to solve the various problems that occur in architectural rendering." — Professor A. H. CARTER, Purdue University.

95 ills. \$3.25. Work Sheets, 13 x 17, \$1.90

BASIC ENGINEERING DRAWING

WILLIAM WIRT TURNER, CARSON P. BUCK, and HUGH P. ACKERT

— all of the University of Notre Dame

INTRODUCES the student to all the basic principles of engineering drawing, descriptive geometry, and machine drawing. Designed to fill the need for an integrated course, this one-volume textbook is flexible enough to be used by instructors whose teaching needs cover only one of these fields. The presentation of all three phases of basic engineering drawing assumes no previous knowledge of the subject on the student's

part. Text material and coordinated problem work stress the application of theory to best current industrial practice. "I feel that the authors are proceeding in the right direction by combining *Engineering Drawing with Descriptive Geometry* in one text. It is well organized, well illustrated, and well written." — Professor W. A. WOLFE, The University of British Columbia, Vancouver, Canada

563 ills., 26 tables, 669 pages. \$5.50

INTRODUCTION TO MECHANICAL DESIGN

T. B. JEFFERSON, Editor, "The Welding Engineer;" and
WALTER J. BROOKING, M. W. Kellogg Company

PRESENTS mechanical design from the viewpoint of the creative engineer actually designing machines, rather than as a series of different machine elements involving separate problems. The subject is approached as a whole, in light of a machine's functional purposes, configuration requirements, economic aspects, use of rational and empirical data, and desired appearance —

setting these in their proper perspective as weighed by the experienced designer. "I have been searching for a really good book in *Machine Design*. After giving this text a fairly comprehensive review, I believe that it is far ahead of any other work in its field." — Professor GEORGE W. CARTER, University of Utah.

373 ills., 102 tables, 612 pages. \$6.50

**THERE'S A
VEMCO
DRAWING
SET FOR
every NEED**

VEMCO sets are available in stand-
ard and special arrangements—in
four types of cases—and in these
two grades:

VEMCO hand finished stainless steel
Blue Dot instruments are supreme
in accuracy, durability and finish.
The professional or the student
engineer will take pride in these
instruments.

VEMCO chrome plated steel Red
Dot instruments are outstanding in
quality, yet popularly priced. These
instruments are having favorable
acceptance in many of the leading
universities.

Write for a free copy of "Historical Note on
Drawing Instruments."



Here is the striking new pocket size
(4 1/4" x 7 1/2") VEMCO saddle leather case
with zipper closure. This set No. H-171-L
includes 6 1/2" Bow Compass, 4 1/2" Bow
Compass, 6 1/4" Friction Divider, 5 1/2"
Slip Handle Ruling Pen, and Tube for
extra leads and points.

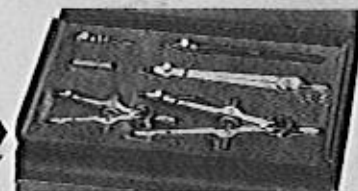

Set No. A-171-V

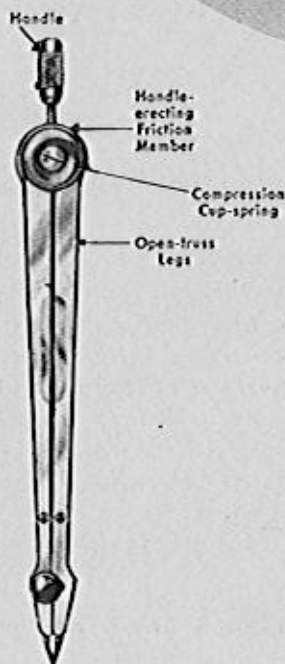

**VEMCO "CUP-SPRING"
FRICTION DIVIDERS**

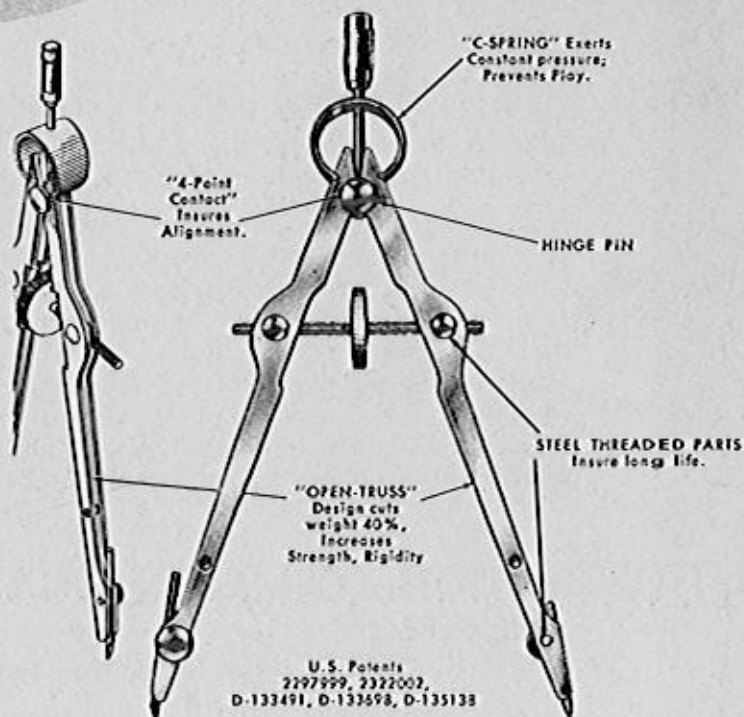

U. S. Patents
2297999, 2322002,
D-133491, D-133698, D-135138

VEMCO OPEN-TRUSS COMPASSES

VEMCO Patented Open-Truss Design is
used for all VEMCO compasses. They pro-
duce critically accurate results in both
heavy pencil and finest ink work.

V & E MANUFACTURING CO. • PASADENA 20, CALIF.