

The Journal of Engineering Graphics

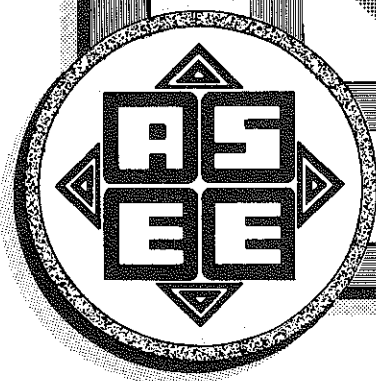
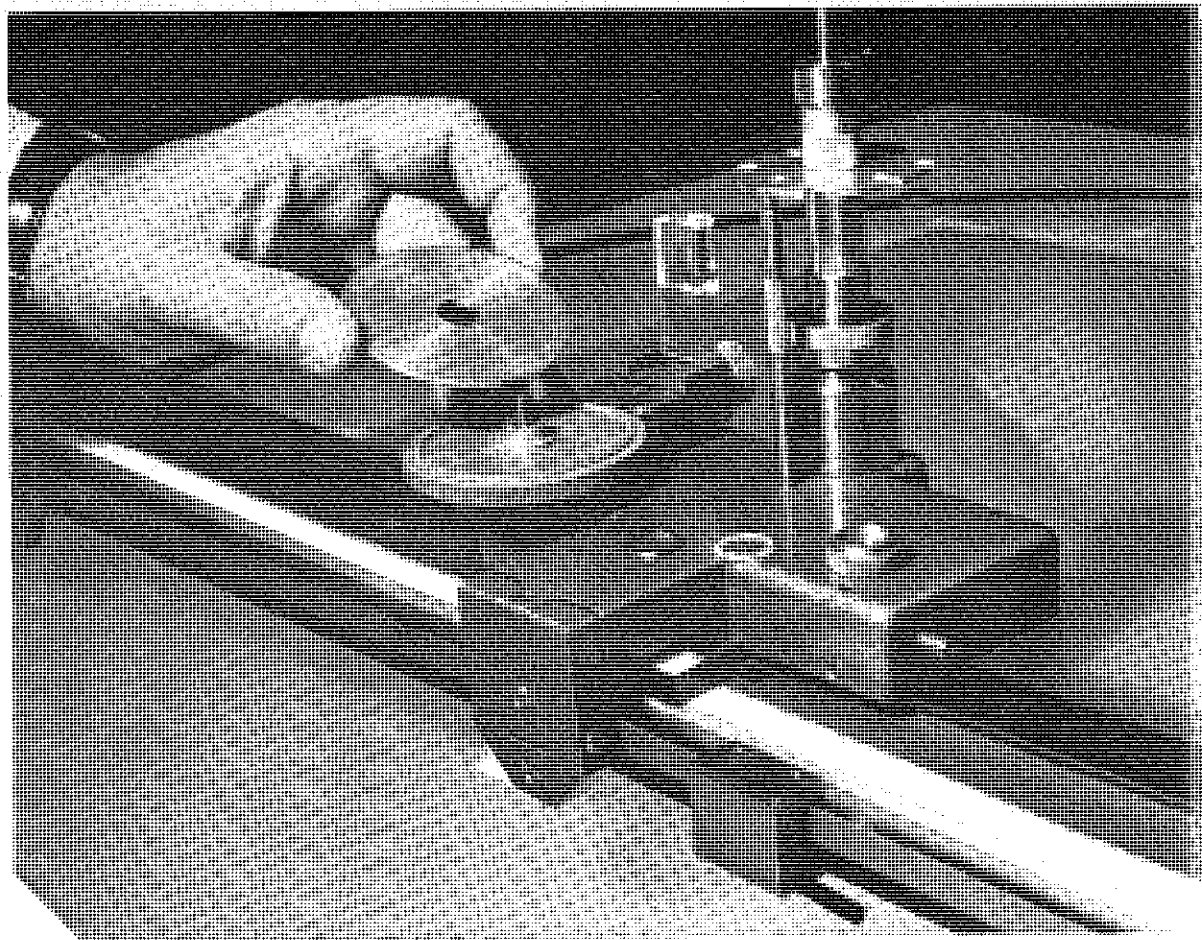

May (Spring) 1966

Vol. 30, No. 2, Series 89

Published by the Division of Engineering Graphics, American Society for Engineering Education.

Stimulating Engineering Graphics Text

Partne

FO
this means . . .
and FACTUA

NOT TRICKY
WHICH HIDE
FANCY NAME

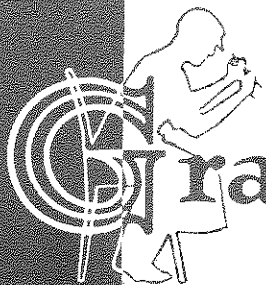

Frame

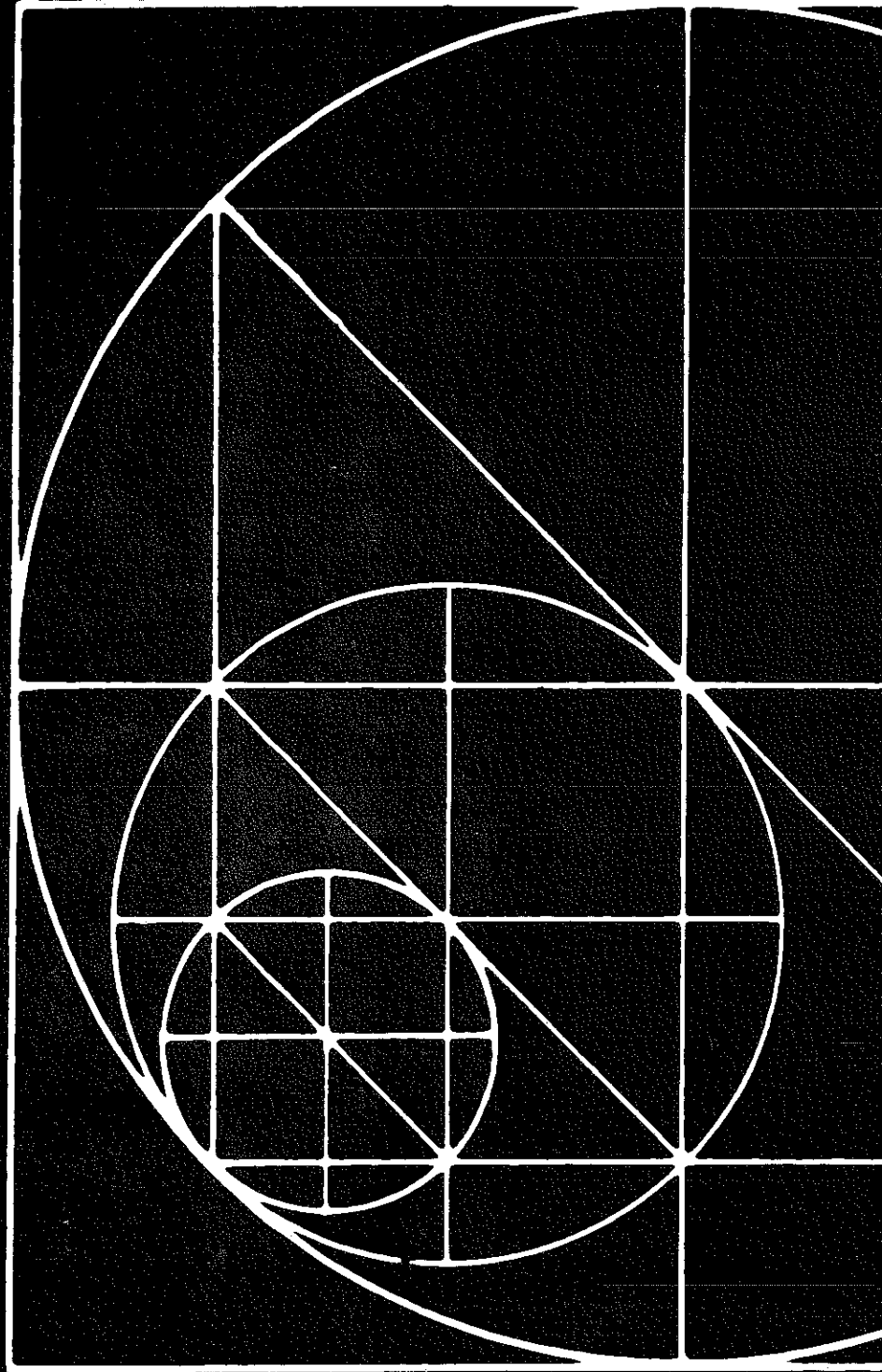

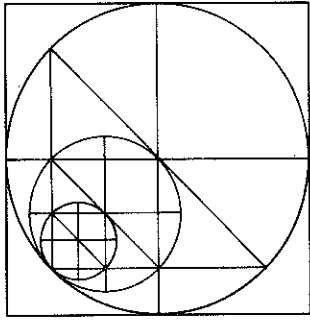

A MANUAL OF ENGINEERING DRAWING FOR STUDENTS AND DRAFTSMEN, Tenth Edition

By **THOMAS E. FRENCH**, The Ohio State University; and **CHARLES J. VIERCK**, University of Florida. Off press.

In this tenth edition of the most successful engineering drawing book, color illustrations are used for the first time. Shades of red and brown make the book more readable, aid in three-dimensional visualization, and help to separate the important from the supportive. Six hundred new problems are included, many of them drawn from such diverse fields as medicine, oceanography, prosthetics, and basic research. A new chapter, The Fundamentals of Design, defines design . . . gives insight into the design mentality . . . delineates procedures-materials selection, proportioning, construction, and manufacture . . . introduces some aesthetic considerations.

FUNDAMENTALS OF ENGINEERING DRAWING, Second Edition

By **THOMAS E. FRENCH** and **CHARLES J. VIERCK**. Off press.

Designed for the freshman course, this fundamentals text consists of the first thirteen chapters of **A MANUAL OF ENGINEERING DRAWING FOR STUDENTS AND DRAFTSMEN**, Tenth Edition.

SUPPLEMENTARY MATERIALS AVAILABLE: Engineering Drawing Problems (for use with Tenth Edition); Fundamental Engineering Problems for use with Fundamentals text, Second Edition); Teacher's Manual (for use with both texts).

INTRODUCTION TO GRAPHICAL ANALYSIS AND DESIGN

By **E. LEIGHTON WELLMAN**, Worcester Polytechnic Institute. Ready for Fall classes.

This modern engineering drawing text, written by a leading scholar-teacher, is designed for the one-semester course or the first half of the two-semester course. Throughout the book, freehand drawing is emphasized and applied to problem solutions whenever possible. In graphical analysis, the close correlation and remarkable equivalence of mathematical solutions is stressed.



Send for your examination copies today

McGraw-Hill Book Company • 330 West 42nd Street • New York, New York 10036

The reading and visualization of multiview drawing is thoroughly developed with logical and well-tested methods. The final chapters provide the basic elements for an introduction to engineering design. Each topic is fully illustrated, thoroughly explained, and demonstrated with examples. A large selection of problems follows each chapter.

ENGINEERING DRAWING PROBLEMS:

Series I, Second Edition

By **HIRAM E. GRANT**, Emeritus, Washington University. 64 pages, \$6.50.

This revision is a two-in-one workbook; two sets of problems of each type are printed on opposite sides of each workbook sheet so that the instructor can choose either one of the problems and have an alternate available for the following term.

PRACTICAL DESCRIPTIVE GEOMETRY, Second Edition

By **HIRAM E. GRANT**. 208 pages, \$6.95.

Here is a timely revision of this well-liked and widely used text for the standard one-semester descriptive geometry course. The applications have been obtained by the author's visits to hundreds of industrial plants.

CREATIVE PROBLEMS FOR BASIC ENGINEERING DRAWING, Alternate Edition

By **MATTHEW McNEARY** and **CLAUDE Z. WESTFALL**, both of University of Maine. 104 pages, \$5.95.

Introduces elementary design to the beginning student, stressing conceptual rather than analytical design. All problems are new. Drawings are made from verbal descriptions.

COMPUTER GRAPHICS IN COMMUNICATION

By **WILLIAM A. FETTER**, The Boeing Company. 128 pages, \$4.50, clothbound. Soft-cover Text Edition available for classroom adoption, \$2.50.

Designed to explain the increasingly important field of computer graphics — a technique for producing drawing, stereo views, and motion pictures by computer. Typical problems illustrate current applications, potential applications, and representative projects.

ALL TYPES OF COPIES

SEE IT NOW!

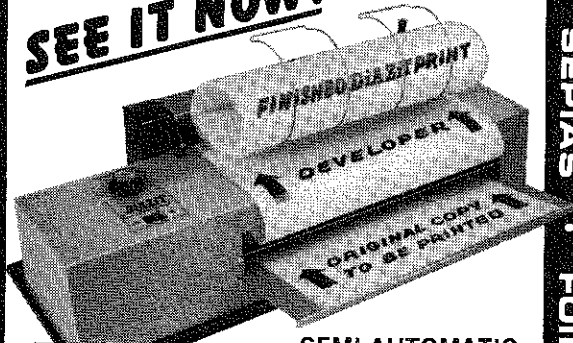

BLACK OR BLUE LINES • MYLARS

SERIAS • FOLDS • ACETATES



SEMI-AUTOMATIC
WHITE PRINTER
WALL OR TABLE
OPERATION...

Before you spend \$600.00, \$750.00, \$1200.00 for a dry copy whiteprinter, get your free demonstration of the "DIAZIT". Like thousands of others—after evaluating and comparing DIAZIT'S design and aesthetic features—your faith will be restored in the phrase "TRUE DOLLAR VALUE".

42 INCH COPY 469⁵⁰ / 18 INCH COPY 379⁵⁰

For local dealer and brochure, write:

DIAZ-IT Company, Inc.

MONMOUTH JUNCTION, N.J. • TELEPHONE—201-AX 7-9030

In Canada: HUGHES OWENS CO. LTD., 8500 Decarie Blvd., Montreal, Que.

F.O.B. Monmouth Junction, N.J.

Editors' Board

CHANGE, PROGRESS, AND CONTROVERSY

Now is the time to plan the future in engineering graphics. Over reduction of fundamental principles can become detrimental to the future of engineering. Verbal understandings change meanings. Most people in the United States think of the written and spoken English language when the word communication is used. This is wrong. Engineering communication combines graphical concepts with mathematics and the written and spoken language. The Engineering Graphics Division must become its own severest critic in what is basic to practical engineering. And all of us should become expert salesmen for engineering graphics as a servant to engineers.

In analysis, change alone may not be progress. Some changes in the engineering curriculum have been dishonest -- changes which have caused a drop in numerous college enrollments in engineering. Furthermore, many complaints have come also from industrial employers of our students. Some changes have been due to honest forethought and logical examination of situations at hand. Many of these so-called changes, however do not reflect the thinking and opinions of engineers as a whole. Change is one thing; progress is another. Change should be scientific; progress is a subject of controversy. It is easy to mistake momentum for progress.

Looking over the broad spectrum of services performed by engineering graphics for the engineer or scientist we may compile a long list. Engineering graphics helps build a vocabulary needed by the engineer. It helps to clarify engineering intent. It is a tool for analysis. The smaller the firm, the more diversified should be the abilities of the engineer. Also, the larger the firm, the more specialized should be the abilities of the engineer but only after a mastery of basic fundamentals, especially in the area of graphical communication. Engineering graphics is an aid to computations and assists in three-dimensional concepts. Graphics is a form of simulation and tends to give real meaning to abstract mathematics in size and shape details. Graphics helps to generate a mental reaction and assists the engineer in application of knowledge and fundamentals to problems which arise during design activity.

Time after time industrial representatives have complained that engineering graduates have

ample knowledge in the sciences, but do not have the capacity of application. The gap has been widening between the educational needs of the engineer in industry and the educational offerings of American higher education. Practicing engineers cannot avoid the use of graphics. Modern industry has reached its high level of productivity, not so much through individual effort as through organized and correlated working teams. This correlation is done largely by graphical communication. Furthermore, ability to communicate completely is a prime requirement to most executive promotions.

New and good ideas provide good products and engineering graphics assists the flow of information constantly demanded by manufacturing and industrial supervisors. Men, money, machines, and intellectual capital are the ingredients of industry and business. Most industrial supervisors insist on their engineers having a good ground work in engineering graphics principles. The new look in engineering education should mean a stronger emphasis on basic theory and at a higher level of difficulty -- a level of difficulty equivalent to that of other courses being taken by the students at the same time. We weaken our position if we introduce advanced material too early. We also lose by half doing any job. We should select and design assignment projects which will permit the promotion of an engineering attitude on the part of the student.

Engineering graphics is no longer just an art but has developed into a definite science and should take its place along with mathematics as a cornerstone to an engineering career. It is the communications link between the design engineer and those who participate in the manufacturing world -- the process engineer, the quality control group, the sales staff, the service technician and the customer consumer. The demands of advancing technology and the pressures of competition will continue to make change the most fundamental aspect of the future. We may not be the first to pick up the new, neither should we be the last to lay down the old. But let us scientifically examine the situation at hand and stop grasping at straws for salvation. If we can only substantiate the need and know-how for engineering graphics, the world is ours.





Officers' Page

IS THERE A DOCTOR IN THE HOUSE?

E. W. Jacunski, Vice Chairman
ASEE Division of Engineering Graphics
University of Florida

When in 1953 the Professional Scientific curricula approach to engineering was adopted, and the Professional General was rejected, an engineering gap began to widen. Like a chameleon changing colors, graphics endured as a basic study only by changing its traditional form, proliferating its name, and shifting its emphasis. In many schools severe reduction in time has caused it to become a mere academic gesture with its graphics faculty decimated by transfer to other areas, by dismissal, by retirement, or by promotion to positions in the Office of the Dean.

The gap continued to widen until the rising ground swell of opinion brought the conviction that the Scientific Oriented educational program is not relevant to the needs of many technical industries -- industries who previously found their sales, maintenance, operation, construction, manufacturing and management personnel among engineering graduates. Graduates were just not being trained or educated to go into these fields.

In 1961, the ECPD gave tacit recognition to the fact that, from the extreme of the technician to the research scientist, there existed many gradations of essential work that required an appropriate pattern of professional development to fulfill the total engineering team effort, and that "... adequate recognition of the total pattern of the engineering team effort in maintaining standards of professional development may well be one of the significant steps required in the near future." Accordingly, in 1965, The Preliminary Report of the Goals Committee resulted.

As individuals and as a Division, graphics has tried to shore up this widening gap in its area of preengineering instruction. It is doubtful if any area of instruction has been as valiant in its resourcefulness to maintain course coverage against the pressures that were buffeting it about from every source, and at a time when its field was growing more complex with newer applications uncovered by advances in technology.

Graphics' voice in curricula structuring has always been minimal. There are isolated cases of graphics instructors who, by the virtue of passing years and seniority in tenure, have been granted positions of affluence as Committee Chairman, or as Assistant Deans. Their degree

of enthusiasm and their personal convictions relative to graphics may be reflected in small measure in the status of graphics offerings in their schools.

But with no voice in curriculum planning there was no effective opposition when the Grinter Report pushed graphics to the bottom of the time ladder and to a doubtful position as a significant engineering subject. Academic administrators, concerned with new courses and increasing credit hours for graduation, judged graphics by their own experiences of twenty and thirty years ago. They remembered the chisel pointed pencil, the hours of lettering, the ink-smearred plates and the neatly formed arrowheads. This definition of graphics naturally placed it low on the scale of importance as an engineering subject within the framework of a scientific-oriented curricula and the squeeze was on.

As new names -- products of the scientific-oriented program -- appear on the administrative roster they, paradoxically, add to the current dilemma in graphics by appraising its value by a still different set of standards. Thus adding another hurdle to challenge further graphics involvement.

Let us assume that the Goals Report has given the future of graphics a nod of approval. The time, therefore, is at hand when the Division ought to speak in clear words and simple language what it stands for, what it can do and what it is prepared to do for engineering education, if permitted to do so. The goals Report has provided broad guidelines and has suggested analysis, design and engineering motivation as the avenues graphical communication should follow. If ever before an opportunity to do a selling job presented itself for the reestablishment of graphics as an important and basic course in the engineering core of subjects, it lies within the months ahead. The Goals Committee Report, even when amended in final form, will have -- as the Grinter Report did -- a significant impact on the future of Engineering Education. Colleges and universities will be evaluating and reorganizing their curricula to phase in with its education projections. With the recognition that modern technology has a wide spectrum of activity and has a preponderant need for professional rather than scholarly

Continue on page 43

OFFICERS

PAGE

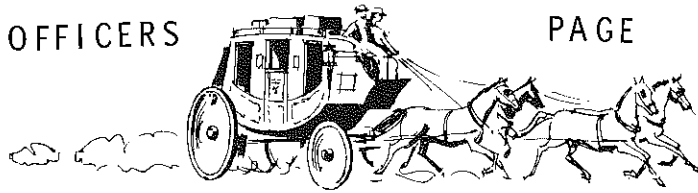

DIVISION OF ENGINEERING GRAPHICS
ASEE ANNUAL MEETING PROGRAM
UNIVERSITY OF WASHINGTON
PULLMAN, WASHINGTON - 1966

Sunday, June 19
6:00 - 10:30 p.m.

DIVISION OF ENGINEERING GRAPHICS
ASEE ANNUAL MEETING PROGRAM
UNIVERSITY OF WASHINGTON
PULLMAN, WASHINGTON - 1966

Sunday, June 19
6:00 - 10:30 p.m.

Executive Committee Dinner and Business Meeting
(Committee and Invited Guests Only)

Monday, June 20
10:00 - 11:45 a.m.

CONFERENCE

Theme: Geographics and Communication
Presiding -- Steve M. Slaby, Princeton University, Princeton, N.J.
First Paper -- Computer Graphics by William A. Fetter, Supervisor of Computer Graphics, The Boeing Company, Renton, Washington
Second Paper -- Geographics, The Modern Reunion of Geography, Geometry, and Graphics by William Warntz, Research Associate, The American Geographical Society, New York, New York
Discussion, other speakers and comments.

Tuesday, June 21
12:00 - 3:45 p.m.

LUNCHEON and BUSINESS MEETING

Presiding -- J. Howard Porsch, Purdue University, Lafayette, Indiana

Wednesday, June 22
10:00 - 11:45 a.m.

CONFERENCE

Theme: Developments in Teaching Graphics
Presiding -- Edward W. Jacunski, University of Florida
First Paper -- Tape Controlled Automatic Drafting Machine by Leon J. Arp, Iowa State University, Ames, Iowa
Second Paper -- Programmed Learning in Graphics -- The Vehicle or the Launching Pad? by Richard D. Springer, University of Minnesota, Minneapolis, Minnesota
Third Paper -- The Design Process for Freshman Engineers by William S. Chalk, University of Washington, Seattle, Washington
Discussion, other speakers and comments

6:00 p.m.

ANNUAL BANQUET Open

Presiding -- J. Howard Porsch, Purdue University
Illustrated Lecture: The Mystery of the Mayd by Irwin Wladaver, New York University, Bronx, N.Y.



DIVISION OF ENGINEERING
GRAPHICS ELECTED OFFICERS
1966-1967

- E. W. Jacunski Chairman
University of Florida
- E. G. Pare' Vice Chairman
Washington State University, Pullman
- M.G. Mochel Secretary
Clarkson College of Technology
- C. W. Chance Director
University of Texas
- W. B. Rogers Divisional Editor
United States Military Academy ASEE Editorial Committee
- K. E. Botkin JEG Advertising
Purdue University Manager
- J. H. Porsch Divisional Representative
Purdue University ASEE Coun
- E. W. Jacunski Divisional Representative
University of Florida ASEE Coun



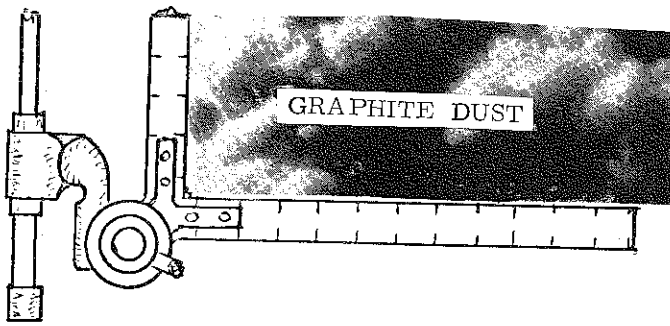

Black and White -- 27 minutes
 Available from Lincoln Lab, Lexington, Mass.
 02173

"DAC-1" -- General Motors
 Available from General Motors Corporation,
 Public Relations Staff, Film Library,
 Detroit, Michigan 48202

The following films are available from Bell
 Telephone Laboratories:

- "Force, Mass and Motion" by Sinden
- "A Pair of Paradoxes" by Shepard and Zajac
- "Two-Gyro Gravity-Gradient Attitude System"
 by Zajac
- "A Computer Technique for the Production of
 Animated Movies" by Knowlton



REPORT ON THE JOURNAL OF ENGINEERING GRAPHICS

During the past two years, 226 advertisers or
 potential advertisers have been contacted. These
 contacts have resulted in the following number of
 advertisers during this period.

November 1963	10
February 1964	17
May 1964	19
November 1964	21
February 1965	20
May 1965	21
November 1965	20
February 1966	18

These ads are informative about new develop-
 ments in engineering graphics, equipment, and
 services to teachers. The editorial staff would
 like to suggest that our readers patronize them.

Respectfully submitted,

Myron G. Moche
 Advertising Manager



"Mental impact is greater with GRAPHICS."



The Editors of the Journal of Engineering Graphics
 are seeking articles dealing with practical appli-
 cation of graphics in problem solutions, and ar-
 ticles which explore the theoretical aspects of
 graphics.



Continue on page 62

John B. Bennett, Editor of ASEE Publications,
 met with the Journal of Engineering Graphics staff
 at General Motors Institute on May 10 and
 December 6, 1965. His subsequent correspondence
 indicates that he thinks his visits were "highly
 rewarding." As a result of these meetings, we
 received record forms and other information
 from Mr. Bennett that will help us form a stronger
 liaison with the parent organization. He has
 further indicated interest and willingness to assist
 us by forwarding to us articles and inquiries
 regarding engineering graphics. Mr. Bennett
 was also pleased with our financial status at the
 time of his visit.

John B. Bennett, Editor of ASEE Publications,
 met with the Journal of Engineering Graphics
 staff at General Motors Institute on May 10 and
 December 6, 1965. His subsequent correspond-
 ence indicates that he thinks his visits were
 "highly rewarding." As a result of these meetings,
 we received record forms and other information
 from Mr. Bennett that will help us form a stronger
 liaison with the parent organization. He has
 further indicated interest and willingness to assist
 us by forwarding to us articles and inquiries
 regarding engineering graphics. Mr. Bennett
 was also pleased with our financial status at the
 time of his visit.



We would like to remind our readers that a
 complete Author and Subject Index of the Journal
 of Engineering Graphics may be had by sending
 your request to:

Professor James H. Earle, Circulation
 Manager and Treasurer
 Engineering Graphics Department
 Texas A&M University
 College Station, Texas 77840



All prospective authors should carefully read
 Information for Authors.



MOVIES ON COMPUTER GRAPHICS

"Graphic Data Processing" -- IBM
 Black and White -- Approximately 40 minutes
 Available through local IBM representative

"Sketchpad" -- Lincoln Lab, MIT
 Kinescope of program prepared at
 Lincoln Lab for National Educational Television

LETTERS TO THE EDITOR



Rio de Janeiro, February 2, 1966

Dear Professor Black:

The following is a reaction that has been brewing in my mind for some time. If I did not speak before, using the opportunities given to me, was first, because I wanted to use those occasions to make divulgation of my studies and second, because I had fears of being called presumptuous and accused of having ideas divorced of the reality. I am talking about the situation with Graphics. The attitude of the professors, of those responsible for the development and study of Geometry, and of those against it. The situation is not "rose," say some. We should "bark" under some other tree, suggest others. This is not a subject of interest to the engineer, guarantee many others.

This pattern, this repetition of "what is and what Graphics is not" is a common thing, not only in the United States but also in Europe, Asia, and South America. A general feeling of defeat is found in all lands. The future shows heavy clouds of doubt.

What has been brewing in my mind is this: most of the people who are repeating this negative attitude over and over again, year after year, are nothing more than "cry babies." Or, if they feel offended with the qualificative, they are like the politicians at the time of the Roman Empire, who would commit suicide by orders of Nero.

For this is what has been going on: someone with the least notion of what Geometry is, turns around and says: "this (Geometry) can be replaced; that is no good; graphical methods are obsolete; forget about the whole thing and come to our side or die . . ." I ask: what are we doing? Answer: we believe it!! We get around tables, talking for hours and writing long reports about the many advantages of studying Graphics. Reports that are read by few of us. They never reach, really, those who already do not see, do not listen, do not talk about Geometry. At the same time, many in our midst "just cry" or "just die." They have cut their own wrists because the sophisticated "Neros" have so ordered.

As in a fight, which is decided inside the ring and not by comparing measurements and brute force, by the same token it is not with reports, and long talks, and speeches, and conferences among ourselves that we are going to prove that Graphics is any good. We must go into the ring even though the opposition is saying that we are going to lose. Up to now we have been looking at this opposition and just . . . fainting. I say: "let us get some ammonia under our noses."

To do this is to write; is to make research; is to go looking into their (the opposition's) fields and not only understand them but show how Graphics can help; is to publish (but not papers showing

how to use templates on the chalkboard . . .); is to criticize our own work and the opposition's work. If necessary, appeal to the "ignorance factor" and demonstrate that Geometry, in fact, preceded Mathematics. Very simple, as shown below:

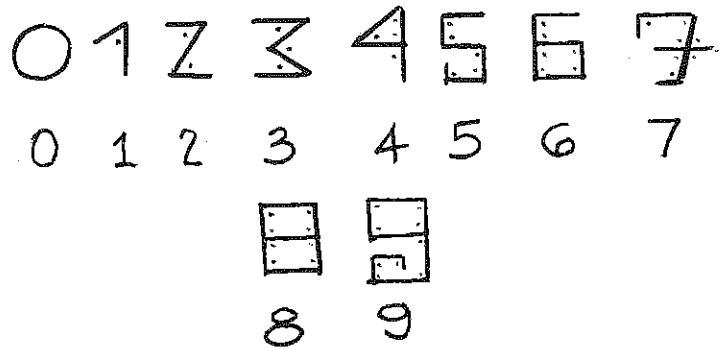

(Each number is represented by the number of angles. Therefore, the geometric concept preceded the concept of numbers . . . However (but do not mention it), how do we "count" the "number" of angles?)

Use this kind of double-talk to impress them, for they have impressed us, greatly, with much more childish arguments. If Graphics is not having a good time, let us make their life much more miserable. Let us counterpunch.

In times such as these I am not too concerned about what the other side is doing: I am doing something. I want that the worries will stay with them. Gives me time to act. -- I do not believe in sitting in a bathtub full of warm water, cutting my wrists and waiting for the death to come. This was all right for Seneca, the great gentleman of the Roman Empire. But Nero just had a great laugh. The world lost Seneca, a great mind, and had to live with Nero. Therefore, I repute Seneca's attitude, a silly one, if not stupid.

Let us take a good look at something that happened here in Rio where I am vacationing: Professor Felipe dos Santos Reis, retired, 70 years old, just published a work of Geometry to be read "by adults only." In other words: we have got to know a lot of Geometry and Mathematics to appreciate it and to judge it. It is an important work. To be applied. -- Well, this work was written in 1915, but only in 1965, putting all his savings together, was he able to publish it. This attitude is that of a fighter who wins in the last round, with many cuts and bruises. He is tired, he is bleeding, but he won. He is not like Seneca, who died crying, attended by his servants and friends who would pour perfume in his bath of death . . .

I say this: geometers, graphicists (or graphicians and other icians), all over the world, are pouring down perfume in the bath where Geometry is dying. We are all very much interested in the final result. We blame others but we are not doing much to save it, (except to hold conferences among ourselves and write reports that are read by those who write them in the first place).

Continue on page 28

From The Macmillan Company...
The Classic Texts in Technical Drawing
and Descriptive Geometry

Technical Drawing
Fourth Edition

by the late Frederick E. Giesecke, the late Alva Mitchell, and Henry Cecil Spencer, The Illinois Institute of Technology

The Fourth Edition of this distinguished text, which covers all the basic techniques in technical drawing, was published in late August 1958. Its immediate adoption by close to 200 colleges and universities throughout the country was a direct testimony to the reputation it had established. Since then, a continually mounting list of adoptions reflects the enthusiasm with which this edition has been received. It includes over 700 figures and many air-brushed illustrations and features an emphasis on technical sketching, which integrates the basic concepts of views with freehand rendering, so that the subject of multiview drawings can be introduced through the medium of sketches. Throughout, the authors' emphasis is on a book that teaches the language of the engineer.

1958, 844 pages, \$9.25

Also Available:

Technical Drawing Problems

Series I, Third Edition, by Frederick E. Giesecke, Alva Mitchell, and Henry Cecil Spencer, 1959, 98 Problem Tear-Out Sheets, 8½" x 11", paper, \$5.75

Technical Drawing Problems

Series II, Second Edition, by Henry Cecil Spencer, 1961, 98 Problem Tear-Out Sheets, 8½" x 11", paper, \$5.75

Technical Drawing Problems

Series III, by Henry Cecil Spencer and Ivan L. Hill, Illinois Institute of Technology, 1960, 80 Problem Tear-Out Sheets, 8½" x 11", paper, \$5.50

Instructor's Manual and Solutions to Problems furnished gratis with the above

Descriptive Geometry
Third Edition

by E. G. Paré, Washington State University, and R. O. Loving and I. L. Hill, both of the Illinois Institute of Technology

Now in its Third Edition, this book has acquired an outstanding reputation as an effective medium for teaching the science of graphic communication as well as providing a broad orientation to those engineering concepts that should be inculcated early in the student's progress toward a professional engineering career. It provides the student with a descriptive geometry textbook in which fundamentals are presented in the same pedagogically sound units of work as they are usually introduced in daily presentations. The material is divided into relatively short, homogeneous chapters, with new principles introduced in order of need and difficulty. To aid students and instructors, problems are given in layout form exactly as they are to be reproduced on the drawing paper. The Third Edition includes full-size, student self-testing problems which provide for the systematic evaluation of comprehension of pertinent fundamentals.

1965, 368 pages, \$6.50

Also Available:

Descriptive Geometry Worksheets

by Eugene G. Paré, Robert O. Loving, Ivan L. Hill
Series A, Second Edition, 1959, 76 Sheets, 8½" x 11", paper, \$4.65

Series B, Second Edition, 1966, 76 Sheets, 8½" x 11", paper, \$4.65

Series C, 1957, 72 Sheets, 8½" x 11", paper, \$4.65

A Key to each Series furnished gratis with the above

Write to the Faculty Service Desk for Examination Copies

THE MACMILLAN COMPANY

60 FIFTH AVENUE, NEW YORK 10011

INVENTIVE DESIGN
INSTRUCTION TECHNIQUES



by

Percy H. Hill, Professor and Chairman of the
Department of Engineering Graphics and Design
Tufts University, Medford, Massachusetts

The techniques discussed in this presentation have been developed over the past six years in a senior level course in Inventive Design. Many of the ideas are not novel in themselves, for they have probably been used by others for many years. The ideas are unique, however, in that they are applications to a single course in design. The objective is unique in that it enhances creativity on the part of the student.

creativity and cannot be taught as the typical analysis course that dominate engineering curricula. One must believe that each individual student possesses creative talent and this talent must be encouraged and nurtured.

Creativity is encouraged through the removal of certain "barriers to creativity." These barriers are identified as two types, one the INSTITUTIONAL and the other the PERSONAL. The institutional barrier consists of grades, class attendance, and fear of the instructor. This barrier is removed by the instructor meeting the class in seminar where the instructor assumes the role of fellow student in free-wheeling discussion sessions. No tests or examinations are required, and class attendance is optional. The second barrier, personal, will be discussed later as the underlying theme of the course.

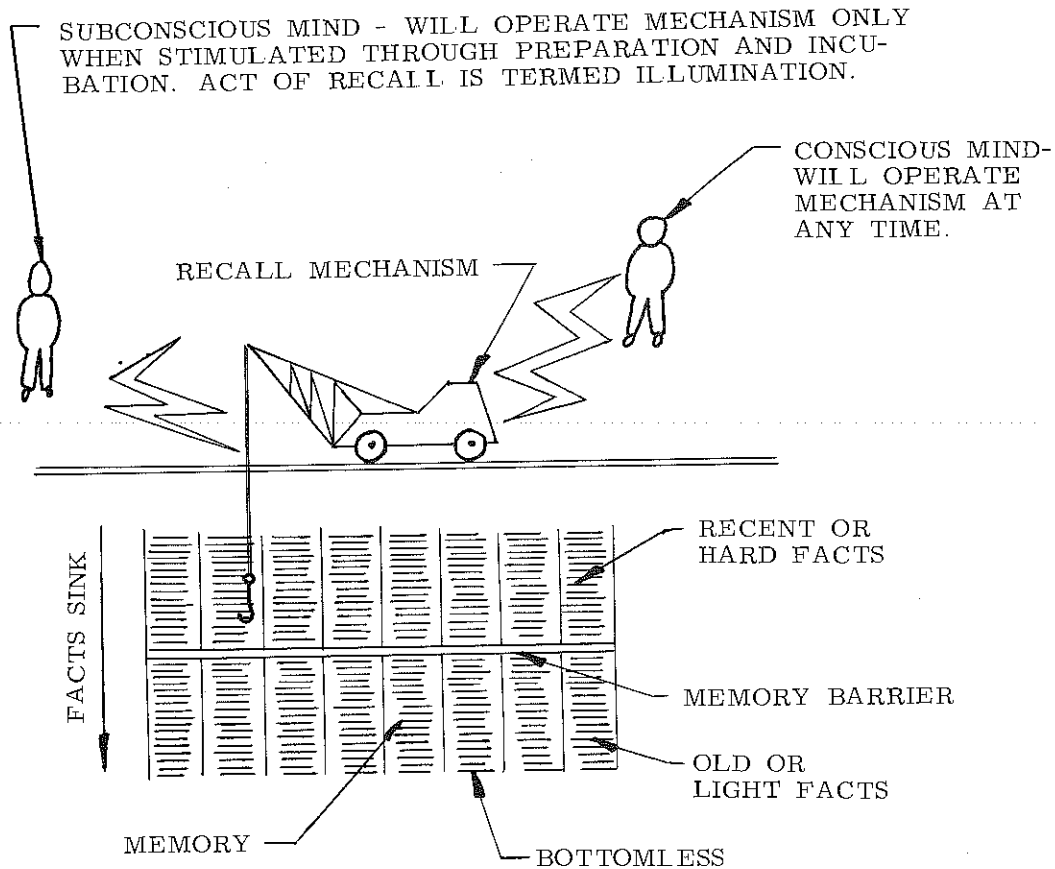

FIG. 1 THE CREATIVE PROCESS

You may ask how this is relevant to instruction in Engineering Graphics. The conclusions show its relevance, and more important, shows the need for graphics in the engineering curricula.

To begin to structure a course in mechanical design, the instructor must be concerned with the creative process. Methods must be devised to involve the student in inventive situations. Design by its very nature is rooted in inventiveness and

The course begins with a discussion of the CREATIVE PROCESS and the following model drawn, as shown in Figure 1.

The process begins with irritating the student by confronting him with a situation and the decision for him to do something about it. Step two in the process is that of preparation in which he consciously explores all possible solutions, and if it is a recent or hard fact, he is able to operate the

*Presented at the Midyear Meeting, Engineering Graphics Division, A.S.E.E., October 22, 1965

recall mechanism and bring it up from the memory. Unfortunately, the recall mechanism cannot be operated consciously to probe below the memory barrier. If the problem or scheme is not solved after exhaustive preparation, INCUBATION will take place as the third step in which the mind is now fully prepared. When trial after trial has failed to produce a new idea, the recall mechanism begins to move rapidly back and forth in the mind and the hook begins to probe deeper and deeper.

ILLUMINATION will take place during a period of rest when the subconscious mind continues to operate. The recall mechanism drops the hook below the memory barrier into the bottomless pit of old and light facts, bringing up a solution unknown to the conscious mind. This "idea" must be quickly recorded, for it will rapidly sink below the memory barrier, not to be recalled by the conscious mind. Once the idea of the solution is at hand, VERIFICATION takes place, in which the idea is tested against the laws of nature.

Students have practiced this process on their design projects, and to their amazement it really works. How many times have you tried to recall the name of a ballplayer, lecturer, or movie star, and even with hard thinking about it, you could not recall the name, but when you are doing or thinking about something not related to the name, it pops into your mind?

Following the session on the Creative Process the class is introduced to the PERSONAL BARRIERS TO CREATIVITY and each is discussed in some detail.

1. FUNCTIONAL FIXEDNESS -- Familiarity with certain objects or concepts establishes a fixed usage, thereby limiting their value. We think of a pencil as a writing tool, even though it can be used as a prop to keep a window open, as a weapon, as fuel for a fire, etc.
2. HABIT TRANSFER -- Carry-over of past conditioning of thoughts and actions to new problems. (Fixed approach.) Attacking new problems with old methods.
3. PRACTICAL MINDEDNESS -- The straight-to-the-point type insists that instead of roaming imaginatively around the problem, we get down to the facts immediately.
4. OVER-SPECIALIZATION -- Specialization may limit one's horizons to the point where his depth is shallow in the engineering and physical world in general, thereby limiting his interdisciplinary conceptual roamings.
5. DEPENDANCY ON AUTHORITY -- Often engineers and students are so impressed by the judgment and approaches of recognized authorities they immediately accept their leadership and fail to develop leadership qualities of their own.
6. FEAR OF RIDICULE -- The highly creative person generates non-conventional ideas. The more creative an individual, the more unconventional his ideas. If the designer is contin-

ually appraising his ideas to see if others will consider them acceptable, he again stifles creativity.

OPERATION PAPER CLIP

The first barrier to creativity, FUNCTIONAL FIXEDNESS, is removed through the assignment of the following weekend project:

An envelope contains the list of ordinary articles shown at the bottom. You are to make use of as many of these articles as you see fit in creating a useful device. Bring your device to class on Monday and give a demonstration of its effectiveness and function.

Time allocated to project . . . 6 hours.

- 12 paper clips
- 1 razor blade
- 6 thumb tacks
- 2 safety pins
- 4 wooden pencils
- 9 rubber bands
- 2 pieces of poster paper
- 1 piece of aluminum foil
- 4 flexible binding pins
- 1 length of wire
- 1 large envelope container

The results demonstrated to the class the following Monday morning are often amazing. Some of the projects presented in class include an ELECTRIC MOTOR, WATER PUMP, RECORD PLAYER, DESK CALCULATOR, CENTRIFUGE, and PIN-BALL MACHINE.

DESIGN PROJECT

The first design project assigned to the class is directed at removing the next three barriers to creativity, HABIT TRANSFER, PRACTICAL MINDEDNESS, and OVER-SPECIALIZATION. This project is assigned by listing the following items singularly on index cards and after shuffling them asking each member of the class to draw a card:

- ELECTRIC RAZOR
- BREAD TOASTER
- ELECTRIC CAN OPENER
- HAIR DRYER
- KNIFE SHARPENER
- VACUUM CLEANER
- GARBAGE DISPOSAL
- ELECTRIC MIXER
- ELECTRIC IRON
- 1/4" POWER DRILL
- ORBITAL SANDER
- SABER SAW
- OUTBOARD MOTOR
- FLOOR WAXER
- DISHWASHER

Following the drawing of cards, the following memorandum is distributed:

Continue on page 42

THE ENGINEERING GRAPHICS PROGRAM

IN

THE PACIFIC NORTHWEST

Roland Byers, Chairman, General Engineering, University of Idaho; John Campbell, Chairman of Engineering Graphics, Oregon State University; Eugene G. Pare, Professor of Mechanical Engineering, Washington State University; Vernon Hammer, Chairman, General Engineering, University of Washington.

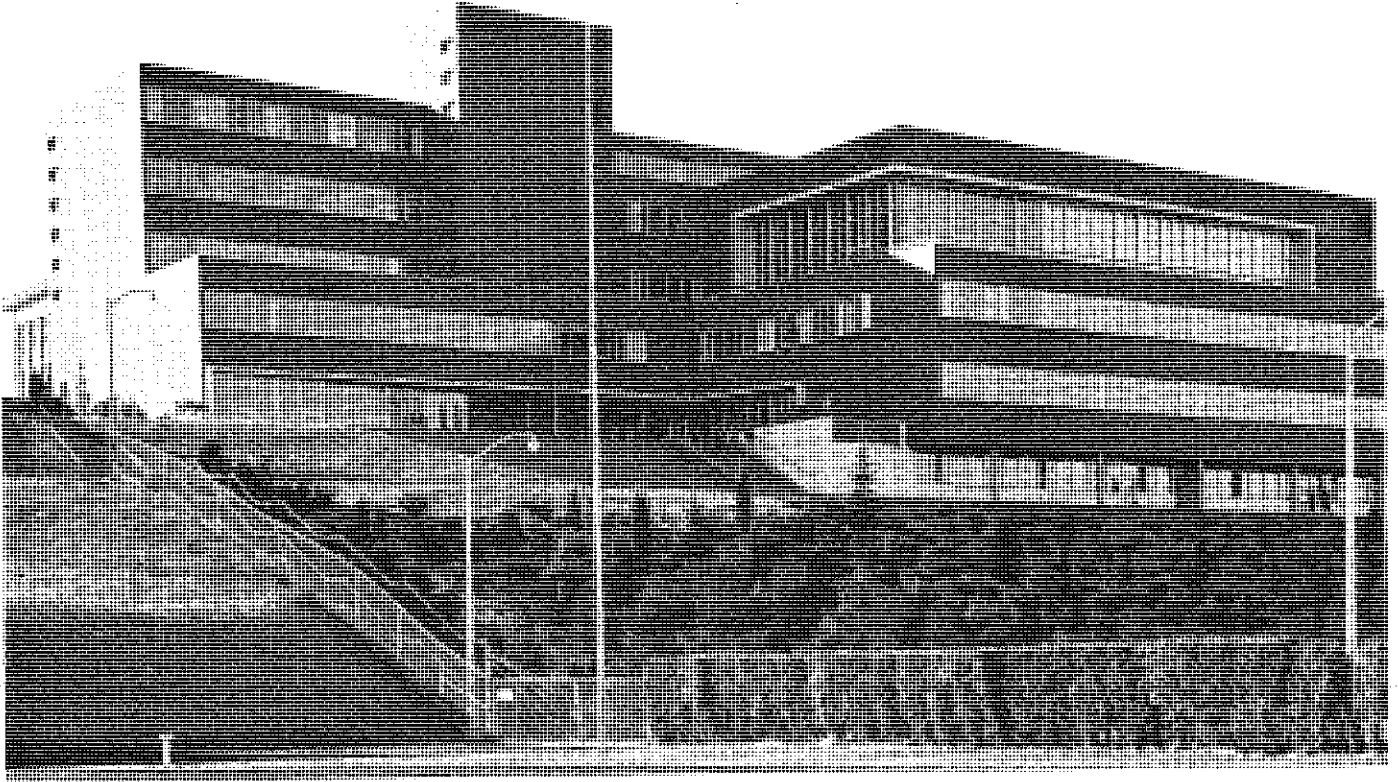

COMPTON UNION BUILDING - WASHINGTON STATE UNIVERSITY

Although the engineering graphics program has expanded and developed independently in each of the universities in the Pacific Northwest, there appears to be an underlying major trend toward a consolidation of traditional engineering drawing material accompanied by a substantial expansion of topics that provide a significant "orientation to engineering." This area has been one of the obvious weaknesses of previous major engineering curricula.

Typical of this trend, the General Engineering Department at the University of Idaho has added to its regular four-credit hour graphics sequence a new two-credit semester course entitled "Survey of Engineering." The new course has been developed to provide an early introduction to engineering concepts through the open-end type of elementary design projects. Faculty from the major engineering departments have cooperated in the planning and staffing.

Oregon State University reports that several years ago the graphics program was rapidly advanced from a mechanical drawing philosophy to what was conceived as a well-rounded offering in engineering graphics. This curriculum advancement proved to be "too little, too late," and for the past three years the major engineering departments have taken over this time for their own engineering orientation courses in which, however, graphics continues to command an important role evidenced by the local bookstore selling nearly as many graphics textbooks as ever. Although most of us will recognize this costly splintering of the program among several departments as a justifiable attempt to strengthen the engineering content of the freshman curriculum, we also surely recognize that the specialization which must inevitably result, is hardly consistent with the more logical trend toward an undergraduate engineering curriculum which stresses the broad fundamentals of the engineering sciences and design. The trend reserves major specialization to the graduate level.

ASEE Annual Meeting

Washington State University, Pullman, Washington, 20-24 June 1966



ROGERS HALL DORMITORY - WASHINGTON STATE UNIVERSITY

Oregon State reports that its Graphics Department is currently occupied with courses for several non-engineering departments as well as a three-quarter term sequence for students classified as pre-engineers. In addition, the department is responsible for an introductory design course for sophomore mechanical engineers. In the future the department expects to develop a concentrated general introductory course that emphasizes three-dimensional interpretation and analysis. Creative design will have firm ties with mathematics, physics, the computer center, and the major engineering departments.

At Washington State University the engineering graphics area has solidified its position by several moves: one of which substantially reduced the cost of instruction and space requirements. This was accomplished by replacing one of the two weekly laboratory sessions with large lecture sections. The basic course, descriptive geometry and a newly organized engineering orientation course were also handled in large lecture sections. Close association with the Mechanical Engineering Department and frequent consultation with other departments has served to maintain mutual respect and promotes a valuable exchange of instructional innovations. The local textbooks for the basic course have been steadily improved by the active

co-authorship of senior ME staff members. Their cooperation has resulted in a significant improvement in the quantity and quality of the engineering orientation aspects of the graphics courses, aspects without which the entire program might well be relegated to the pre-college level.

The trend in graphics is toward a more flexible arrangement of course offerings at the University of Washington College of Engineering. A reduction in required courses and an expansion of electives is included. More emphasis is placed on the analytical and design aspects of graphics and less on the purely descriptive. In addition, the combined offerings in the freshman year at the University of Washington stresses the interrelations of the analytical and graphical approach. This emphasis is being accomplished by demonstrating the common ground in current topics in engineering. As an example, the combining of computers and graphics in computer-graphics. It is also expected that more flexibility will be given in the selection of curriculum by students who can demonstrate either acquired knowledge or unusual aptitude.

All of the universities of the Pacific Northwest trust that during your tour of our area of the country you can find the time to visit each of our campuses as well as our varied recreational facilities.



A RARE APPLICATION OF DESCRIPTIVE GEOMETRY

By James H. Earls, Associate
Professor in Charge of
Engineering Graphics, Texas A&M

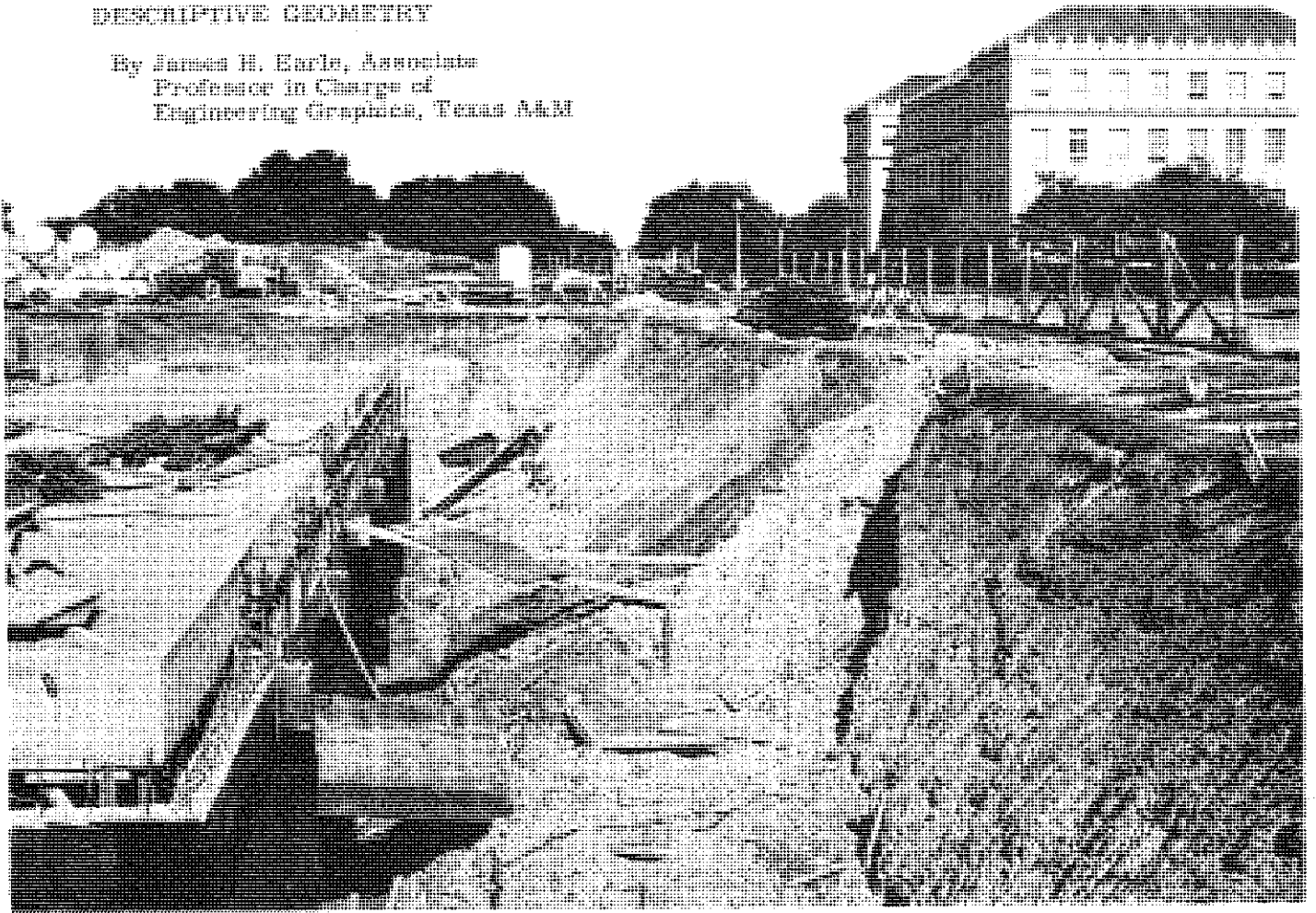

FIGURE 1: Photograph of a hypothetical problem.

The science of perspective drawing involves many principles of descriptive geometry of a rather advanced nature. These principles have been established primarily for the purpose of constructing pictorial representations with little further application. It seems regrettable that the scientific manipulation of perspective drawing has such a limited application.

Recently, a unique engineering problem that lent itself to solution through an unusual application of perspective theory was being studied by a consulting engineer. This problem was concerned with the determination of dimensions of an excavation -- slope, horizontal distance and vertical distance -- from a photograph. The contractor who was in charge of the excavation had experienced several slough-offs and cave-ins from the excavation embankment which caused a considerable increase in cost. Photographs of the construction were made at the time of the failures, but no actual measurements were taken. After the excavations had been corrected and completed, the contractor filed a claim for reimbursement for the extra expense incurred due to the slough-offs of the embankments. He had been given

specifications that indicated the permissible slope and other limits that should permit a safe operation based on the characteristics of the soil. The contractor believed that he was within these specified limits at the time of the failure, and therefore, should receive \$1,000,000 in payment for his additional expense.

A much smaller example is presented in this article to illustrate the principles used in solving this engineering problem by means of descriptive geometry as used in perspective construction. A photograph was taken of a local construction job in an attempt to simulate the nature of the photograph used in the actual problem to avoid reference to the agencies and individuals who were involved. The actual project involved an excavation of several hundred feet approaching a depth of 50 feet. This will be a hypothetical problem that will present the methods employed in arriving at the solution.

THE PROBLEM: Assume that the photograph (Fig. 1) was made at the time of the cave-in of the embankment. The job has since been completed and it is necessary for you to establish the slope

of the excavation and other pertinent information. The photograph is the only source of information.

SOLUTION: The solution is divided into two parts -- the photograph interpretation and the application of perspective principles. Interpretation of a photograph permits a greater possibility of error than does the perspective principles, however, a realistic estimate must be made on the basis of this interpretation -- no other information is available. By overlaying the photograph with a sheet of clear acetate, certain important points and lines may be established during the study of the photograph. It is known that the foundation under construction contains perimeter lines that are parallel and perpendicular to the end of the building in the background to the right. Graphical construction reveals that the horizontal lines of the background building and the foundation structure are parallel in the photograph (Fig. 2). It can be assumed from this that the photograph is equivalent to a one-point perspective with respect to the structures which means that the end of the background building and the end of the foundation are parallel to the picture plane making these surfaces

true size. Planes parallel to these planes will also appear true size in the photograph. Since it is known that the excavation was made perpendicular to the side of the foundation (parallel to the end of the foundation) the slope of the embankment can be measured true size directly on the photograph (this plane is parallel to the picture plane and is therefore true size) with a reasonable degree of accuracy.

It was noted that the embankment was not continuous to the horizontal datum plane of the bottom of the excavation, but was interrupted by loose soil near the bottom. This made it necessary to determine the theoretical point where a true slope line would intersect the horizontal plane at the bottom of the excavation. A shadow cast by some scrap lumber was instrumental in establishing this point. A portion of the horizontal plane is shown undisturbed near the bottom of the foundation. The shadow on this plane resulted in a horizontal trace, E-F, which was extended to the right. Point G was determined to be the point at which the lumber intersected with the surface of

Continue on page 36

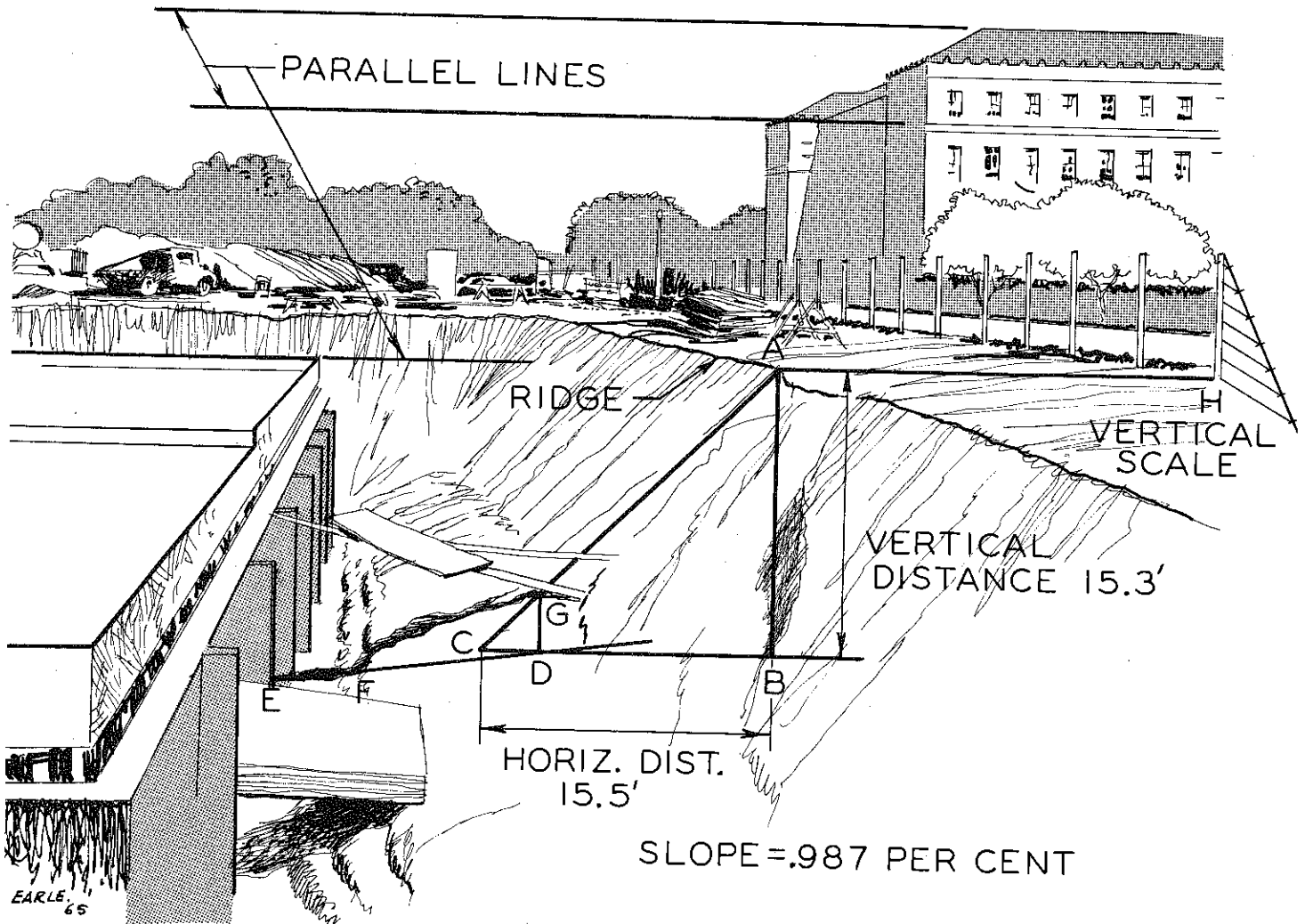
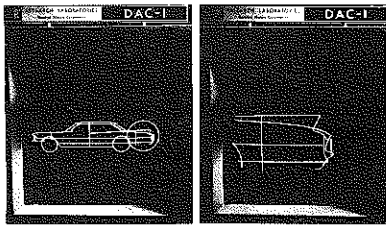
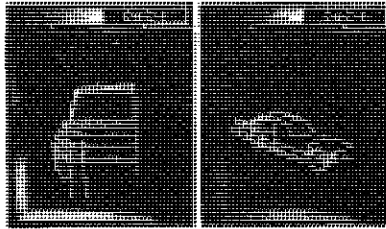

FIGURE 2: Construction of the problem solution as determined from the photograph by means of an acetate overlay.



ENLARGE



CHANGE VIEWS

NUMERICAL CONTROL DRAFTING

by

Donald C. Beran
Process Engineering Dept.
General Motors Institute

Editor's Note:

This article was taken from the paper NUMERICAL CONTROL IN MANUFACTURING given by Professor Beran at Michigan State University during the Midyear meeting of the Engineering Graphics Division of the American Society for Engineering Education.

Numerically Controlled (N/C) Drafting machines evolved from the necessity of having some means of verifying tapes before actual production on the machine tool. Errors in the tape on contouring systems were causing much downtime. The development of drafting machines permitted the tool path to be shown graphically and many major errors could be easily detected. Since early development, other applications have proven most advantageous. Some applications of N/C drafting follow. These were obtained from Allison Division in Indianapolis, Indiana.

Numerically Controlled Drafting machines are currently capable of drawing straight lines at the rate of 400 inches per minute. The velocity decreases substantially on curves and short moves. The accuracy is about $\pm .005$ of an inch with repeatability of $\pm .002$ of an inch. The polar coordinate and logarithm graph masters shown in Figures 1 and 2 were drawn with an N/C drafting machine. Standard graph or grid masters can also be drawn. Large sizes and greater accuracy than produced by photographic processes are among the advantages of N/C for this application.

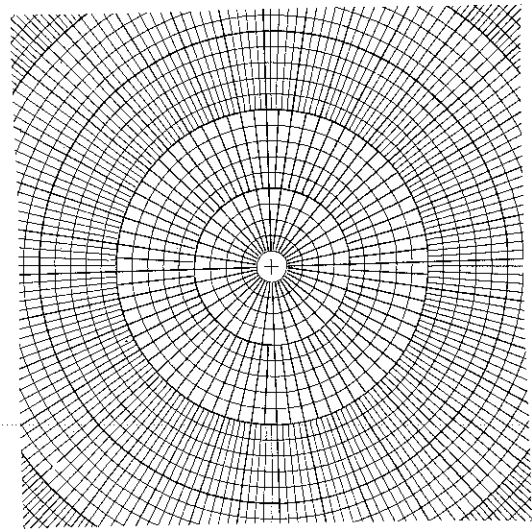

Polar Coordinate Graph Master

Figure 1

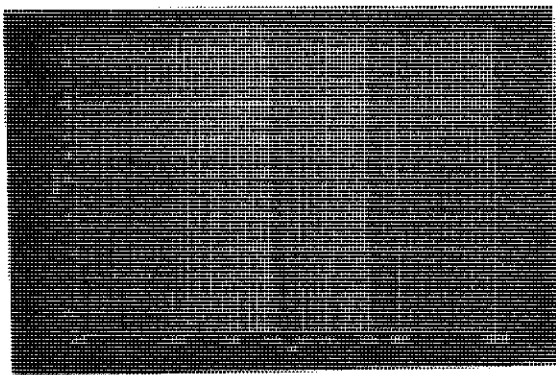

Logarithm Graph Master

Figure 2

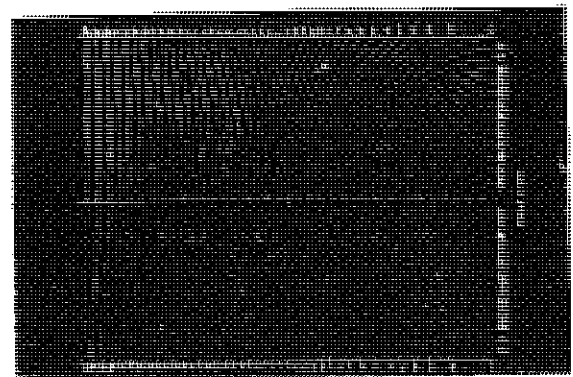

Radius Chart

Figure 3

Figure 3, is a radius chart. It illustrates the flexibility of the machine in drawing from very short to extremely long radii. A plot or playback

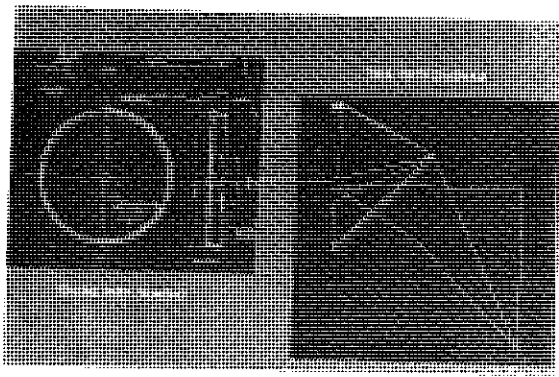

Machine Tool Center Line Path

Figure 4

of a control tape for an N/C machine (Fig. 4) has proven extremely beneficial. It not only conserves work material, but it provides more productive work from an N/C machine tool. Note that the rapid traverse moves are included on the plot, which is misleading to the untrained eye.

An ink drawing of a compressor blade showing the cross-sectional view at several levels along the axis is portrayed in Figure 5. The twist with respect to the axis of the hub and the tolerance lines are included. Drawing time for this type of work is a small fraction of the time required to plot and draw manually. A scribed master to be used on a contour projector can be developed very quickly from the tape for this drawing if the contour is correct.

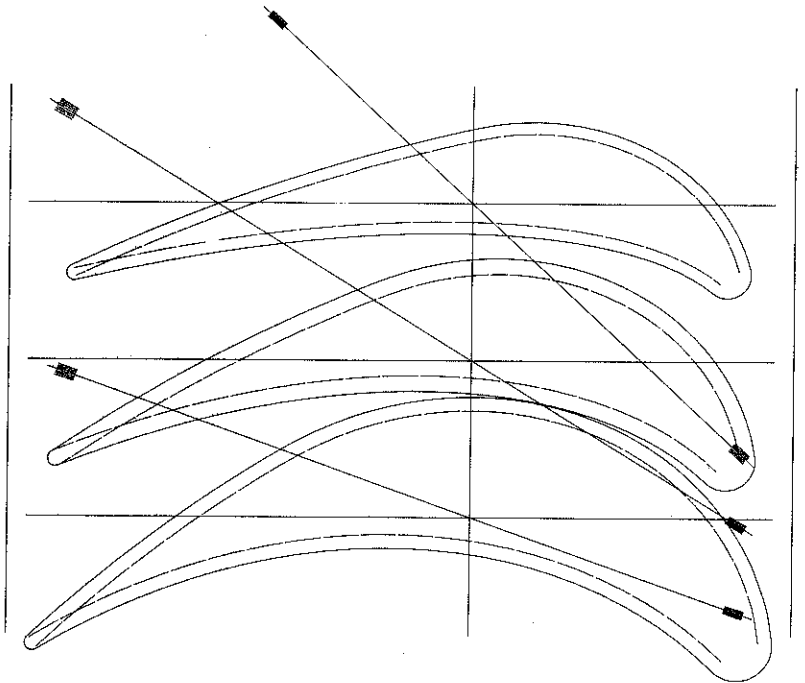

Compressor Blade Cross Section

Figure 5

Figure 6 is an electrical circuit diagram which has good N/C application. Efficiency is attained by programming a symbol and merely repositioning the symbol for new circuitry. Various types of wiring diagrams appear to be a major application in the future.

HAVE YOU SOLVED THESE?

(Draw a profile view.)

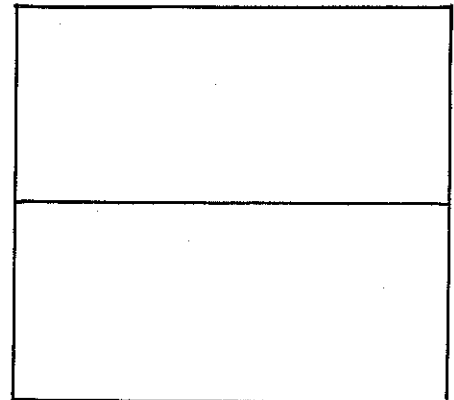
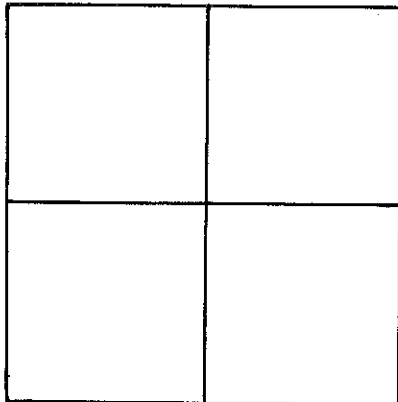

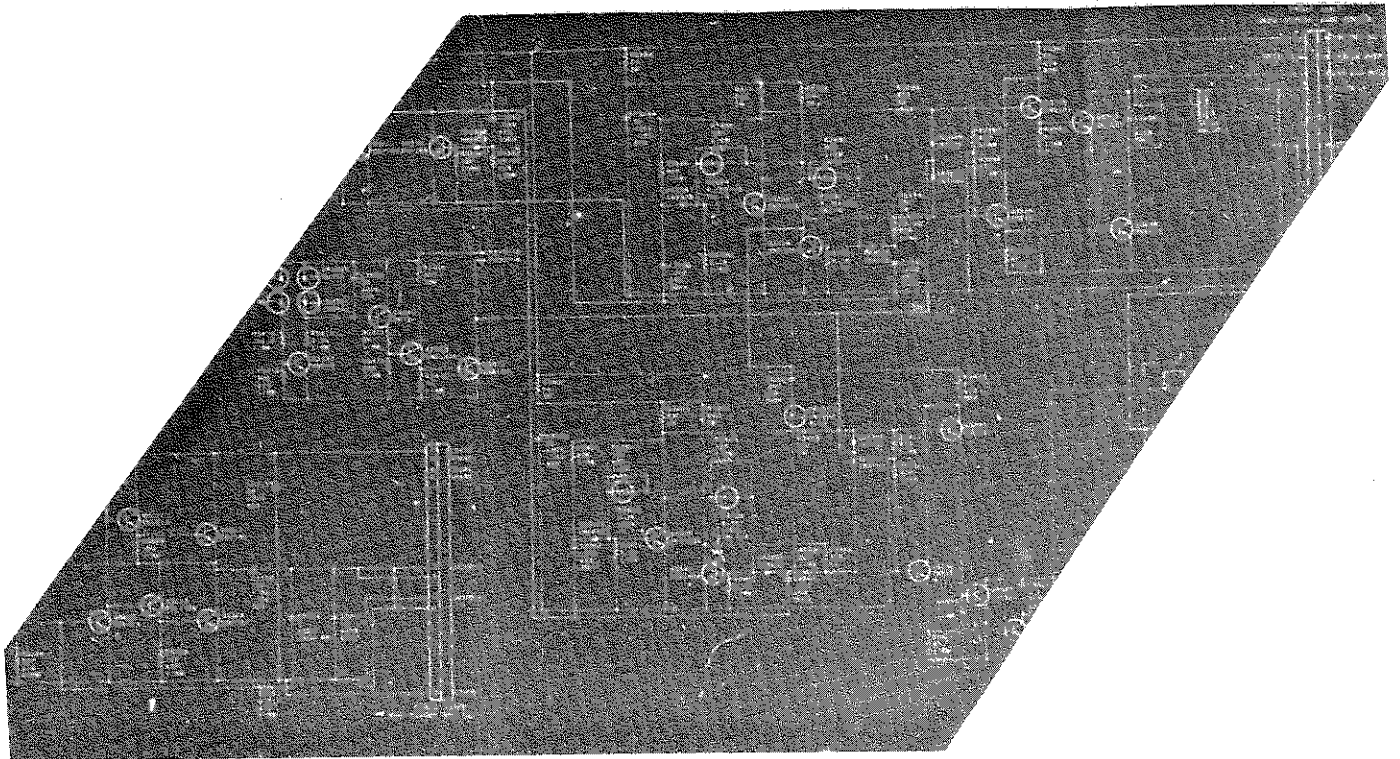

Electrical Circuit Diagram

Figure 6

An Allison experiment that proved "uneconomical" for N/C drafting is illustrated in Figure 7. The programming time exceeded the time to draw the part manually. The part does not have complicated surfaces, and programming the lettering was lengthy. This experiment was done a few

years ago. More recent developments have made lettering and some other routines more automatic which requires less programming. On the newer drafting machines, this drawing may now be economical to produce.

Continue on page 48

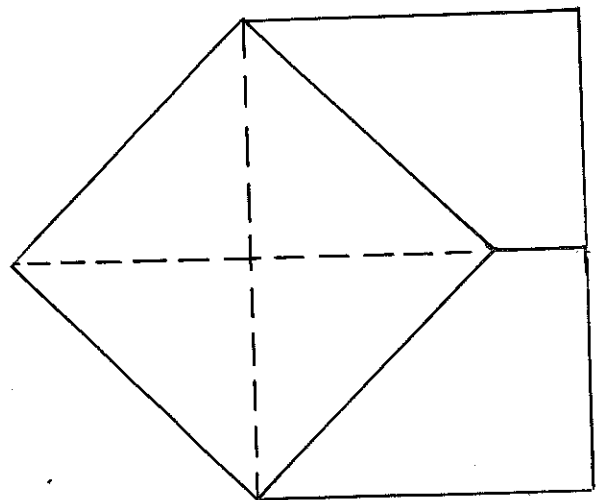
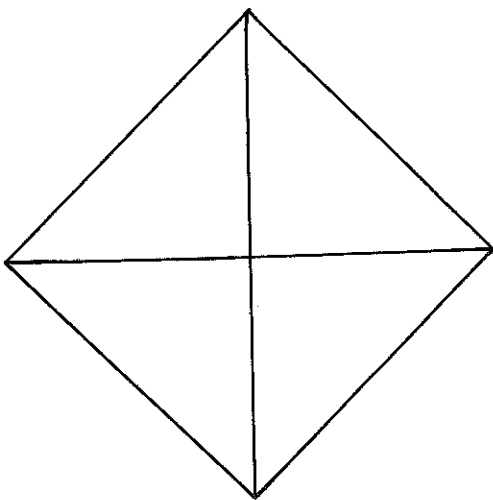



COMMENTS ON THE GOALS OF
ENGINEERING EDUCATION

PRELIMINARY REPORT

Submitted by
The Engineering Graphics Division
of
The American Society for Engineering Education

INTRODUCTION

The original report prepared by the Engineering Graphics Division answering each question in Information Document No. 3 was submitted to the Goals of Engineering Education Study Committee on July 15, 1964. This report contained a position paper on the importance of the inclusion of engineering graphics in undergraduate curriculum. The original report constituted a consensus that was discussed at the Midyear Meeting of the Engineering Graphics Division in January, 1964, as well as the annual meeting in June, 1964. Answers to Supplemental Document No. 3 were submitted on February 1, 1965. The Supplemental Report was adopted at the Midyear Meeting of the Engineering Graphics Division on January 23, 1965.

At the Midyear Meeting of the Engineering Graphics Division held at Michigan State University on October 22-23, 1965, the Preliminary Report Document was fully discussed at the executive committee meeting, as well as at several of the general sessions. The Engineering Graphics Committee on the Goals of Engineering Education met and discussed in particular the portions of the report having to do with the inclusion of engineering graphics in an undergraduate curriculum. The general reaction to the report was a favorable one. There are several places where it was felt that a more positive statement concerning graphics would meet the general objectives of articulating graphics in a continuum of engineering design in an engineering curriculum.

Recommendation 4, Page 1.

To be consistent with other statements about the need for communication that appear in the report, Recommendation No. 4 should include a reference to need for communication processes. It now reads:

"Curricula leading to the first professional degree in engineering should continue to be soundly based on the physical sciences, the engineering sciences, and mathematics and, in appropriate cases, on the life sciences."

We suggest the following wording:

"Curricula leading to the first professional degree in engineering should continue to be soundly based on the physical sciences, the engineering sciences, mathematics, and the communication processes and, in appropriate cases, on the life sciences."

Chapter II, Page 11

The Engineering Graphics Division feels that the paragraph on Page 11 that deals with the skill in the use of the scientific method is well written. The paragraph reads as follows:

"Skill in the use of the scientific method (or methods) for solving problems is essential in engineering. Skills in communication -- verbal, graphical and mathematical -- are important. The requisite knowledge and skills are gained from formal educational programs, from on-the-job experience (more frequently now than formerly), and from off-the-job, lifelong learning. The neophyte must not only become a scholar but must remain one."

We compliment the Study Committee for the forthright statement in this regard.

Chapter II, Pages 17-18

The Engineering Graphics Division is particularly well pleased with the statement on the engineering method for solving problems. Most engineering educators teaching engineering graphics applaud the reference indicated because down through the years they have rigorously presented this method through the use of descriptive geometry in engineering graphics courses. Descriptive geometry provides a vehicle for developing communicative skills, as well as developing the ability for three-dimensional visualization so necessary in the morphology of design. Other areas of engineering graphics are also important adjuncts in the communicative processes in effectively arranging and styling written and oral reports.

Chapter III, Page 22

The Engineering Graphics Division was particularly pleased to see the inclusion of the paragraph on Page 22 which reads as follows:

"Engineering graduates, as well as many representatives of management, industry, and government strongly recommended formal training in written, oral, and graphical communications, and reported extensive use of such skills in their own careers. Replies show that management regards both older and new engineering graduates as weak in oral reporting. Neither group was thought to be strong in liberal (or general) education,

although recent graduates were much more likely to be viewed as adequate."

Chapter III, Item 2, Page 24

A considerable amount of discussion in our October 22-23, 1965, meetings was devoted to the paragraph on the top of Page 24 which reads as follows:

"Engineering managers report that recent graduates are stronger in mathematics, physical sciences, theoretical principles, and generally more willing to consider new ideas than earlier graduates. However, earlier graduates were viewed as stronger in engineering design, engineering graphics, and the ability to solve practical problems."

The leadership in the Engineering Graphics Division has been cognizant of the need outlined in the last sentence for a great number of years. A continuing trend for the articulation of engineering graphics courses with engineering design ranging from the freshman to the senior level has been effected in a great number of universities throughout the country by persons in responsible charge of the engineering graphics courses.

Chapter III, Item 3, Page 24

The first paragraph under Item 3 devoted to analysis and synthesis in design strikes a sympathetic chord with engineering graphics educators. The paragraph reads as follows:

"Reports of the Institutional and Organizational Study Committees stressed that increased importance should be given to the general area of engineering design. This view seems to stem from a concern that emphasis on mathematics, science, and general education may result in the deletion of distinctive engineering features, or at least their relegation to a minor role. A need was expressed in these reports for a creative engineering design experience, rather than routine experiences that stress details at the expense of comprehensive understanding."

There has been great emphasis in current thinking as demonstrated by revised textbooks on engineering graphics on the introduction of a creative engineering design experience at the freshman level. This is being done in a number of ways. A greater number of open-ended problems are being used as well as the use of case studies designed to stimulate the freshman engineering student to participate in the engineering decision-making process of the engineering method. A considerable amount of experimentation is being conducted at the present time, and a number of the prominent institutions have come up with some very successful adaptations of this to the engineering graphics courses.

Chapter III, Item 6, Page 25

The Engineering Graphics Division points out that the second paragraph in Item 6 does not reflect a positive attitude toward engineering graphics. It reads as follows:

"The Goals Committee does not imply that such courses as rhetoric, composition, and graphics are unimportant but suggests stimulating the teaching of these courses in high school, as has been done for mathematics and physical science in some high schools, to prepare students better for college level study. Non-credit remedial courses should be provided for students who do not have the necessary proficiency in these areas upon entering college."

Many of us who have been working with the problem recognize that upwards of 60 per cent of the entering students in engineering have not had any previous training in any type of engineering drawing course. In addition to this, many students who had some high school drafting have normally been exposed to the traditional industrial arts approach that is concerned primarily with the development of manipulative skills. This is not the type of engineering graphics course that we in the Engineering Graphics Division feel is desirable. Normally the high school staff teaching these industrial arts types of courses have not had significant training in any of the engineering sciences or mathematics. Those of us who have worked in the development of upgrading courses for the teachers in high schools find that the teachers are, as a whole, unqualified to teach courses in engineering graphics. They do not have creative engineering design experience, either academically or practically, as considered desirable and consequently are not capable of conducting any kind of an articulation effort with engineering design. Further, it is not likely that their qualifications will improve significantly within the next fifteen years.

The training received by high school mathematics and physical science teachers is vastly different from that of the industrial arts people. Many of the mathematics teachers have Master's degrees in their subject matter field as do the physical science teachers. They have participated in the Summer Institute Programs sponsored by the National Science Foundation and have done an excellent job in preparing and upgrading the courses in the high schools in the mathematics and physical science areas. We would therefore suggest some rewording of this paragraph to read to this effect:

"The Goals Committee does not imply that such courses as rhetoric, composition, and graphics are not important, but suggests stimulating the teaching of these courses in high school, as has been done for mathematics and physical science in some high

Continue on page 30

Engineering Graphics, Third Edition

James S. Rising
Maurice W. Almfeldt
Iowa State University

This text presents the basic principles and graphical theory of communication drawings in a logical and integrated manner. Innovations include the initial introduction of orthographic and multiview projection by the study of a point and its spatial location. Experience has shown that the student can better visualize the principles of projection applied to a point in space rather than to a solid object with the complications of invisible edges and surfaces. The next logical step joins two *points* to form a *line*, with succeeding steps to develop basic theory of the *plane* and the *solid*.

Included are numerous illustrations and all appear on the same or facing page as the related text material. This third edition contains an enlarged unit on Production Dimensioning which includes ASA cylindrical parts; Z and N charts; and concurrency charts. Practice problems from the several fields of engineering illustrating principles previously discussed are presented at the end of each unit.

416 pp. — Cloth Bound — \$7.25

Problem Books for Engineering Graphics

Special Edition Problem Books

Designed by You for Your Needs!

Select from Book I, Book II, and a stock of more than 280 additional problems only those problems for which you have a need. With a yearly use of 250 books minimum, we will prepare them to your design — you choose only those problems which you will use, the paper on which you wish to have the problems printed, and the binding you find most suitable. Samples of all problems will be furnished upon request, as well as copies of Books I and II, and the text.

NOTE: An answer key is available for those problems in Books I and II.

Book I

by James S. Rising and Carl A. Arnbal
Iowa State University

This set of engineering graphics problems is keyed to the first 16 units of the text and is designed for a semester's work. Contained are 76 sheets of problems; layouts for practice of graphical theory, engineering applications and worded problems; and quality green tinted drawing paper for all problems. \$3.50

Book II

by Maurice W. Almfeldt and Carl A. Arnbal
Iowa State University

This set of engineering graphics problems is keyed to units 17-37 of the text and is designed for a semester's work. This workbook contains 88 sheets of problems; graph paper in 10 x 10, log and semi-log for the graphical analyses found in units 33-37; and quality green tinted drawing paper for all problems. \$4.50

WM. C. BROWN BOOK COMPANY

135 SOUTH LOCUST STREET • DUBUQUE, IOWA 52001



ENGINEERING PROBLEMS MANUAL, Fifth Edition

by Forest C. Dana and Lawrence R. Hillyard,
Iowa State University

This manual is designed for instruction in engineering problems solving methods and tools as taken by beginning engineering students.

318 pp. — Paperbound — \$3.75

ENGINEERING PROBLEMS WORKBOOK, Fifth Edition

by Forest C. Dana, Lawrence R. Hillyard, and
Gerald W. Smith, Iowa State University

This manual is to be used as a supplement to the ENGINEERING PROBLEMS MANUAL.

160 pp. — Wire Coil — \$3.50

WORKBOOK FOR A ONE TERM COURSE IN ENGINEERING PROBLEMS, Third Edition

by Lawrence R. Hillyard and Gerald W. Smith,
Iowa State University

134 pp. — Wire Coil — \$2.75

BASIC MULTI-VIEW PROJECTION

by Webster M. Christman, Jr. and Earl T. Ratledge,
University of Wisconsin, Milwaukee

This manual contains home study sheets and drawing problems used in the study of orthographic or multi-view projection.

136 pp. — Wire Coil — \$4.75

PROBLEMS IN ENGINEERING GRAPHICS

by B. R. Henry, Lamar State College of Technology

This workbook is made up of orthographic projection, auxiliaries, planes and lines, true lengths and point views of lines, intersecting lines, angle between planes, intersecting lines and planes, intersections, developments, mining problems, topographical problems, cuts and fills, and vectors.

48 pp. — Envelope Bound — \$2.25

ENGINEERING PROFESSIONAL EXPRESSION

by Charles A. Ranous, University of Wisconsin

This text presents material which is necessary for developing proficiency in writing and speaking as a professional engineer.

116 pp. — Wire Coil — \$4.00

DESCRIPTIVE GEOMETRY PROBLEMS

by Kenneth G. Shields, University of Wisconsin

The problems in this workbook are designed to give the student rigorous drill in the fundamental principles of the subject and ample experience in applying these principles in the solution of practical problems.

97 pp. — Wire Coil — \$3.25

MECHANISMS AND KINEMATICS PROBLEMS, Series A and B

by E. W. Jacunski, C. W. Knight, and J. H. Smith, University of Florida

These series include 62 problems each in nine categories plus one set of introductory statements.

Series A, 64 pp. — Envelope Bound — \$2.70

Series B, 64 pp. — Envelope Bound — \$2.70

ENGINEERING SLIDE RULE MANUAL

by Thomas N. Wilson, El Camino College

This manual was prepared to make available for classroom use a collection of exercises sufficient in number and scope to insure that engineering students learn to operate the slide rule with accuracy, speed, and confidence.

110 pp. — Wire Coil — \$3.00

SURVEYING INSTRUMENTATION

by Jesse E. Fant and LeRoy T. Boyer, University of Minnesota

This text presents accurate surveying measurement theory and techniques.

138 pp. — Wire Coil — \$4.75

WM. C. BROWN BOOK COMPANY

135 SOUTH LOCUST STREET • DUBUQUE, IOWA 52001



Perspective

A CASE FOR THE EXPERIENCED PROFESSIONAL TEACHING IN THE FRESHMAN AREA OF UNDERGRADUATE ENGINEERING INSTRUCTION

By Arthur H. Mallon, P.E.
Assistant Professor of Engineering Graphics
Tufts University

Frequently in the past, and more often in recent years, engineers and others encountered at technical and professional meetings have wondered at my teaching graphics and working with students at the freshman and sophomore levels. Some would comment further to the effect that they thought, from the performance of recent engineering graduates, that graphics was not being taught any more.

My response has been something like this: "I am a practicing professional engineer and an engineering college professor. On consulting assignments and during periods of summer employment in private and public agencies there has been ample opportunity to observe the needs of industry and the performance of recent engineering graduates."

Meanwhile, back on campus, I am able to observe the problem there. How to touch all required areas of study and retain the traditional courses? As a result, we trim time allotment and content of existing courses. In this operation, the lower level courses in engineering-related subjects suffer. First, because they must share more of their time with courses in the arts and humanities as well as with math and science courses and second, there is often no one to beat the drums, so to speak, in their behalf.

Take the field of graphics instruction where teachers now and then are the most recent additions to a faculty, marking time until seniority or rank enables them to command a course that they can get their teeth into! Now and then, it is a graduate student who most certainly has more interest in his thesis or orals. One even encounters the tenured malcontent who considers the request to teach graphics with the same relish as an assignment to Siberia.

Whatever the attitude or capability of the graphics teacher, it comes through to the freshman. If the course is the only one of those he is taking which resembles, or can be related to the study of engineering, isn't it likely that he will be badly impressed and might therefore abandon pursuit of the engineering degree and profession?

How much better is it when your graphics teacher has taught a wide range of engineering subjects and has a similar spectrum of engineering experience? Suppose he innovates or gives his students a chance to express themselves by application of engineering theory to their exercises in graphics. Let this teacher lend a sympathetic ear to the student and in addition blend in a little guidance, now and then. Top it off with comments and suggestions on how interesting and challenging and rewarding are the courses and career ahead. This attitude on the part of the instructor will not only tend to hold the underclassman on the path to the profession of engineering, but may even attract other undergraduates to its pursuit also.

We need to attract young people who can become engineers. We may accomplish this by high school visits, or underclass guidance, or by teaching the underclass courses in the engineering curriculum. All of this I have done, or now do, and it makes sense. How else can I be assured that I will have continuing senior classes in structural design and where will you hire your next neophyte structural engineer?

For the above and similar reasons, I have for the past twenty years, on four different campuses, been ready, willing and able to teach the lower level courses of which graphics is an example.



"Mental impact is greater with
GRAPHICS."





BY THE GRAPE VINE
ABOUT GOALS OF ENGINEERING EDUCATION



Improved engineering education is essential if the engineer is to play a responsible role in industrial, economical, social, and governmental affairs of the future. We must devote more effort to developing scholarly attitudes on the part of engineering students that they may readily adjust to the needs of new situations. It is doubtful that a single program can be designed which will provide all engineers with the knowledge which they will need for their professional careers. However, flexibility may be provided by an increased number of elective single courses and related groups of courses. The curricula must incorporate new material of engineering importance and discard items of temporary or limited use. Engineering college faculties must be on the alert for new discoveries in engineering science and methods of teaching which are improvements over current practices.

Engineering courses of the future should increasingly emphasize application of design in all courses. The engineer must learn that synthesizing answers to real problems is his chief responsibility. Teachers should instill in their students an increased appreciation that engineers are a vital part of society and should give their total talents and interests far beyond their technical specialties.

Skills in communication -- verbal, graphical, and mathematical -- are important. Engineering graduates, as well as many representatives of management, industry, and government strongly recommend formal training and report extensive use of skills in written, oral, and graphical communications in their own careers. The engineering curricula should include communication (speech, composition, report writing) as supporting disciplines similar to graphics on the one hand and mathematics on the other. These disciplines should have a place commensurate with their value in the training of engineers and be emphasized to a point of making engineers articulate human beings. There should be an insistence upon the development of a high level of performance in the communication of ideas.

Improved effectiveness of teaching is necessary if more scholarly attitudes are to be developed in future engineering graduates. Educational administrators should recognize the need for improved teaching performance and the difficulty of teaching design-oriented courses. Attention should be given to improved methods in the selection and training of future teaching staff members. Since both technology and engineering science are advancing so rapidly, technical obsolescence of the present teaching staff should also be prevented by faculty improvement programs and scientific development of teaching methods.

Many companies have designed programs that

help the engineer maintain and improve his technical know-how, but programs at the plant site alone are not sufficient. Effective teaching is a two-way street; the importance and challenge of real industrial problems should become more apparent to the instructor. Programs of continuing education will require careful planning and organization to be most effective.

Useful creative effort in design is the main concern of the engineer. His job is using available science and technology to solve present-day problems within a limited time and economic limitations. Future scientific discoveries are likely to result in technical problems of ever increasing complexity and depth. The engineer must be prepared to accept and use new and improved developments in science and methods as they become available. Gaps will develop in the engineering education program if it is allowed to continue the trend toward de-emphasis in the synthesis and design phases of engineering. The solution of increasingly complex problems will require a higher degree of sophistication plus information from an ever widening variety of sources and will frequently involve a coordinated team effort of many individuals and disciplines. Engineers will need an extremely flexible type of formal education.

Engineering students confronted mainly by faculty of other disciplines do not obtain a proper insight into engineering; they may even be motivated away from it. The engineer's training should be aimed at developing the ability in making new applications and synthesizing solutions. He should not just use current techniques and scientific applications pertinent to his field, but he must continue his education throughout his entire professional career.

More contact of every sort should be provided between the engineering faculty and students. This contact should occur throughout the student's undergraduate training especially through the critical first two years.

Significant amounts of engineering design should be incorporated into each and every engineering course. This may not be accomplished in overly large classes. While some faculty members are able to achieve a relation of affinity with students of a large class, the majority of teachers need a grouping of smaller classes in order to be most effective.

Better utilization of the student's time must remain a constant goal. Research-oriented and a design-oriented curricula should not widen the already existing gap between the two orientations.

Continue on page 35

Four definitive books for Engineering Graphics from HAYDEN

Here are four books which demonstrate the widening scope and importance of engineering graphics as a means of scientific and technological communication. They range from the basic considerations of the craft to the sophisticated analysis of information, detailing areas where engineering graphics makes, or can make significant contributions to understanding.

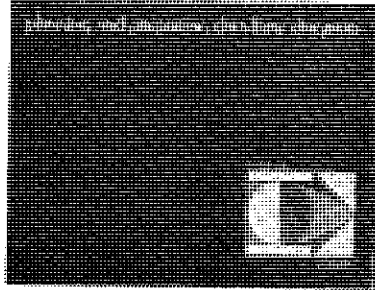

PLANNING AND PREPARING DATA-FLOW DIAGRAMS

J. J. DiCerto. This complete guide defines and describes the entire procedure for laying out a data-flow diagram. Layout procedures and drawing techniques are detailed, with six different illustrative examples presented step by step. 90 pages. 11 x 8½". #5027, Clothbound, \$10.50

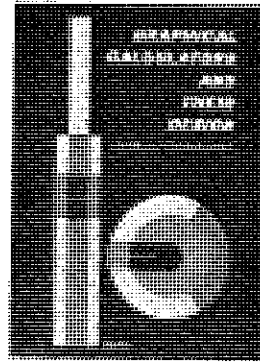

GRAPHICAL CALCULATORS AND THEIR DESIGN

Norman Crowhurst. A comprehensive guidebook for selecting, designing, and constructing effective graphical calculators for manipulating and displaying data. 96 pages. 7¾ x 10¼. #5020, Clothbound, \$5.95

GRAPHICAL ANALYSIS

Philip Stein. This unique explanation of the correct plotting of data on modern graphs demonstrates graphs as an effective tool in understanding the laws and phenomena of science and technology. 288 pages. 6 x 9". #5041, Clothbound, \$8.00

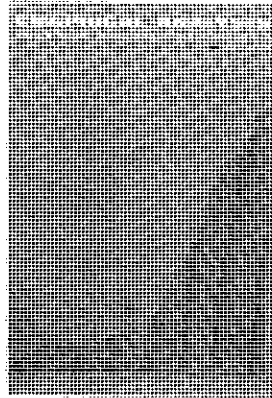

GUIDEBOOK FOR MECHANICAL DESIGNERS AND DRAFTSMEN

Edwin T. Yates

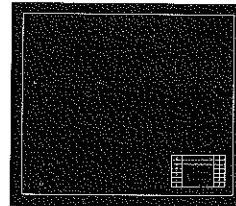

GUIDEBOOK FOR MECHANICAL DESIGNERS AND DRAFTSMEN

Edwin T. Yates. This valuable reference and text demonstrates the relationship between pure and practical design. It shows how mechanical design must consider the processing and assembly aspects of the machine shop. 160 pages. 6 x 9". #5579, Clothbound, \$5.95

Instructors may obtain further information and examination copies

by writing:

*Carl E. Mischka
Educational Sales Manager*

HAYDEN BOOK COMPANY, INC., 116 W. 14 St., New York, N.Y. 10011

Gentlemen: Please send me the book(s) checked below on 30-day approval with appropriate discount.

#5027 #5020 #5041 #5579

Name _____

School or Company _____

Address _____

City _____ State _____ Zip _____



COMPUTER DRAWINGS
by
ENGINEERING GRAPHICS STUDENTS

By Norman Buchanan
Assistant Professor of
Engineering Graphics
Pennsylvania State University

Engineering Graphics students in some of the elementary graphics courses at the Pennsylvania State University drew the pictures shown in the figures with a computer-controlled plotter. What the students contributed is data (punched by them on cards) for two already written programs, one a pictorial-procurer, donated by Douglas Aircraft (for teaching use only), and the other a graphing program, written at Penn State University.

To get a picture like the one in Figures 1 and 2, the student must sketch an object, assign a number to each relevant point, and estimate the X, Y, and Z coordinates of that point. He then decides which points are to be connected, and lists sequence numbers which later route the pen (connecting the dots). The student then punches the location and sequence cards, with pre-specified formats, and also a control card which includes the title, student name, turn and tilt angles, the observer's distance from the object, paper size, and number of location and sequence cards. The instructor usually gives individual help with this key control card, checks a listing of the cards, submits the program and cards at the computation center, and returns the pictures to the students. One number, the distance from observer to object, determines whether the picture will be an isometric as in Figure 1, or a perspective as in Figure 2.

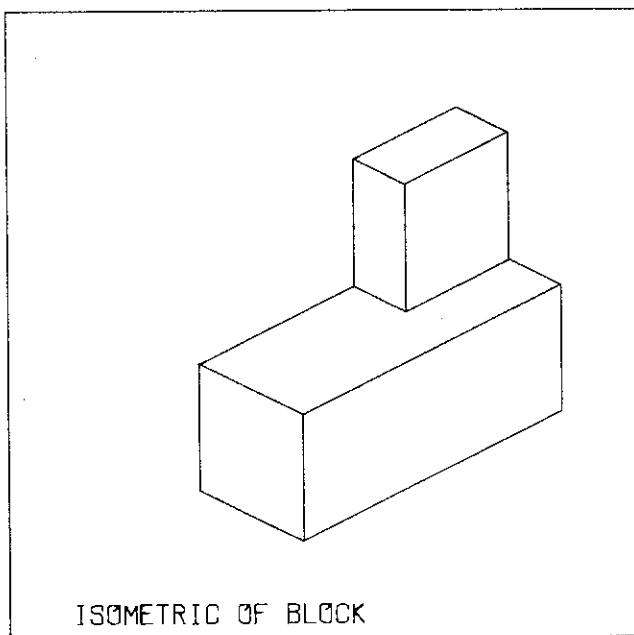

FIGURE 1

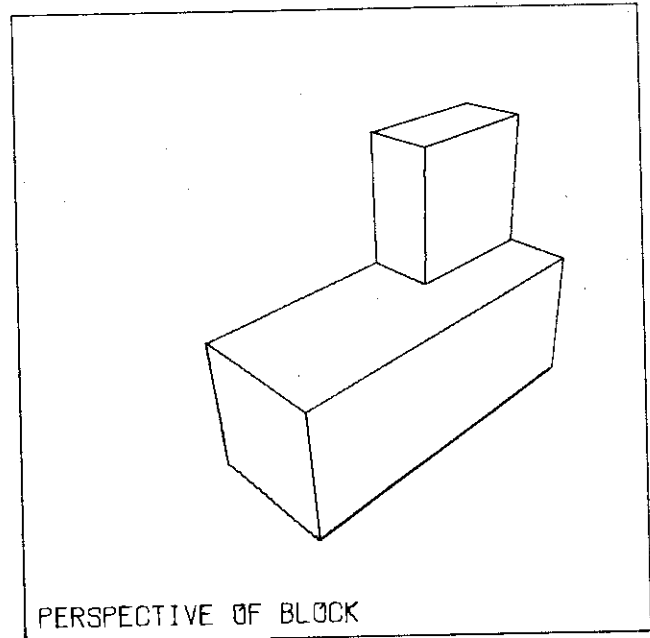

FIGURE 2

To get a graph like that in Figure 3, the student punches cards containing his name, the graph title, labels for both axes, and the ordered X-Y coordinates of the desired points.

The actual drawing is a two step process. An IBM 7074 computer calculates the two-dimensional coordinates for each salient point on both the lettering and lines that are to appear on the graph or picture, then loads numbers on magnetic tape, later read by a 1401 computer which controls the pen and drum movements of a cal-comp plotter.

Listings of the data cards which gave rise to Figures 1, 2, and 4 are shown in Tables 1, 2, and 3.

Grid and circle-drawing subroutines are available to motivated students for use with the pictorial program, and also curve-generating subroutines for use with the graph program. Examples of other first-run student results with these subroutines are shown in Figures 4 and 5. As can be seen in Figures 4 and 6, the program does not determine visibility, nor does it insert

Continue on page 55

Something is missing. And the word is GUTS.

Sincerely,

C. Ernesto S. Lindgren
U. S. Steel Corporation

Re: Article, Journal of Engineering Graphics
Wladaver versus Lindgren
Vol. 29, Number 3, Series 87

Dear Editor:

Just a few lines to you for a question which neither of the two learned men mentioned above could possibly object to or answer.

What is a point? Why of course, it is a location in space. Aha, but, SUPPOSE that there isn't any space, not even the four dimensions that we today are aware of ????? NO SPACE . . . IS A POINT THEN CONCEIVABLE?

If you think about a point, you think about it being SOMEWHERE!!!

If you have a line, you can IMAGINE a point SOMEWHERE ON IT. BUT a point is just a location, and IF there isn't anywhere for it to be located, it is NOTHING!

A point needs a LINE to hold it. Take away the point's LOCATION and it just isn't there anymore.

Think about a line . . . If it isn't in a surface, does it EXIST? A line is an ORDERED SEQUENCE OF POINTS . . . but where does the order come from? Why from being in a surface!! For if a line isn't held by a surface, then it would collapse into itself because a line HASN'T ANY WIDTH!!!!

Therefore, a point needs a line; a line needs a surface; a surface has to be a part of space or its structure vanishes. Space needs hyperspace to hold it, etc., . . . etc., . . . each dimension demands one higher or geometry ceases to exist -- just as we need these little mental skirmishes amongst the higher echelon of intelligentsia (self excluded naturally).

I will lay you odds that Irwin Wladaver won't sleep for awhile until he can sharpen the right spearhead and Lindgren will feel that he has an ally at least in the Midwest.

Respectfully yours,

Wayne Felbarth
Associate Professor of
Engineering Design & Simulation
University of Detroit



IN MEMORIAM

Professor Richard Carpenter

Professor Richard C. Carpenter and Mrs. Carpenter passed away on the 18th of June, 1965. Services were held at Soiler-Baker Chapel, Lafayette, Indiana and interment was at West Point Military Academy, West Point, New York.

Mr. Carpenter was a graduate of West Point Academy 1929, The Infantry School, Fort Benning Georgia 1933, The Field Artillery School, Fort Leavenworth 1940, Command and General Staff School 1943, Chicago Academy of Fine Arts 1948, and M.S.I.E. degree from Purdue University 1955. Mr. Carpenter was a military career man from his graduation from West Point until his retirement from the military late in the period of the Second World War. He rose to the rank of Colonel in the U. S. Army and was wounded in France which required some two years of hospitalization.

Between the military service period and joining Purdue in 1953 Mr. Carpenter did commercial art work in Chicago. Mr. Carpenter came to Purdue in 1953 as instructor in Engineering Graphics. He was promoted to Assistant Professor in 1956 and to Associate Professor in 1961. His work in the graphics area at Purdue was in the field of Technical Illustration.

His first love was art. He had a great many paintings that had won honors. He and Mrs. Carpenter, with leave of absence from Purdue, spent the year 1957 traveling and painting in Europe. He was always in demand as an art instructor in Lafayette and other locations. He was responsible for the layout and set of drawings which showed, in full color, the artificial satellite and three-stage Vanguard Rocket launched into space during the International Geophysical Year.

Professor Carpenter was a member of the American Society for Engineering Education, Palette and Chisel Club, Chicago, The Oak Park Art League, and The Lafayette Art Association. He was a contributing author to Introductory Graphics published in 1958. Author of an article "Some Gleanings from Commercial Art," Engineering Drawing Journal 1954.

We of the Engineering Staffs will miss Professor Carpenter and we have extended our sympathy to the daughter Lois Carpenter Boone and her husband who live at Bakersfield, California. Lois is associated with a Social Security records and investigation group. Lois has turned over to the graphics area many of her father's things which have been placed for loan to staff and students.

The Carpenters were very interesting people and no one could wish for better friends. Their idea of what lies beyond death can be summed up in their statement.

"Don't grieve. We believe there is a pleasanter world and we hope to see you and other friends there."

CREATIVE PRODUCT EVOLVEMENT

by J. Liston, P. E. Stanley

Published 1965

Price \$5.00

190 pages; 8½" x 11", -- a book which is profusely illustrated with example cases of new-product evolution, and contains a large number of practice problems particularly designed to stimulate imaginative thinking. Many of these problems are based on real situations that offer the challenge which comes from knowing that a good answer might have commercial potential.

Unique in its field, and particularly emphasizing the methods of synthesis, a step-by-step procedure is presented for conceiving, describing, and proving ideas and proposals for new and better products.

Chapter titles are: 1. *Preparatory Steps in Evolving a Complex Product*. 2. *Conceptual Methods and Techniques in Creative Product Evolution*. 3. *Spatial Visualization*. 4. *Disclosures and Patents*. 5. *Feasibility and Optimization Studies*. 6. *Feasibility and Optimization Studies with Analog Computers*. 7. *Feasibility and Optimization Studies with High-Speed Digital Computers*. 8. *Experimental Confirmation of Feasibility*. 9. *Planning the Feasibility Test Facilities*. 10. *Proposal Reports for New Products*. Appendix: *Practice Problems in Creative Synthesis*.

*DESCRIPTIVE GEOMETRY PROBLEMS and **ADDITIONAL DESCRIPTIVE GEOMETRY PROBLEMS

by S. B. Elrod, C. H. Zacher, H. F. Gerdorf

*Published 1962

**Published 1965

Price \$4.50 (for both)

*128 problem sheets, 8½" x 11", on good quality paper, perforated and bound into a book.

Appropriate for an extensive course of 90-100 lab hours. Content includes: basic orthographic projection, fundamental spatial relationships of elements; applications of descriptive geometry to design and manufacture. There is extensive coverage of intersections and developments, including ruled surfaces; also, axonometric and perspective projection are treated.

**ADDITIONAL, -- includes a number of problems on: *Lofting, Compound Locus Relations*, - also includes improved instruction and variations of certain problem sheets in the 1962 set.

WORKSHEETS FOR INTRODUCTORY GRAPHICS - FORM A

by J. N. Arnold, M. H. Bolds, S. B. Elrod, J. H. Porsch, R. P. Thompson

Published 1958

Price \$4.00

One hundred sheets, mostly 8½" x 11" with a few 11" x 17", on good quality paper, perforated and bound into a book.

Principal topics are: *Lettering, Geometry, Multiview Drawing, Pictorial Drawing, Intersections, Developments, Contoured Surfaces, Functional Design*; also, a few sheets each on *Vectors, Graphical Calculus, Empirical Equations, Representation of Data and Equations*.

GRAPHIC AIDS IN ENGINEERING COMPUTATION

by R. P. Hoelscher, J. N. Arnold, S. H. Pierce

1963 Printing

Published 1952

Price \$5.75

This well-known text of 197 pages, 6" x 9", in hard covers, deals with alignment charts, empirical equations, the design of special slide rules, and the use of the standard slide rule. Examples are numerous, and there are problems at the end of each chapter.

The seven chapters are: (1) *Standard Slide Rules*, (2) *Empirical Equations from Engineering Data*, (3) *Alignment Charts*, (4) *Graphical Calculus*, (5) *Alignment Charts with Determinants*, (6) *Special Slide Rules*, (7) *Movable-scale Nomographs*.

Formerly available from McGraw-Hill; now a Balt book.

Examination copies of any of these are available upon request.

BALT PUBLISHERS

308 STATE STREET

WEST LAFAYETTE, INDIANA 47906

COMMENTS ON THE GOALS REPORT

Continued from page 21

schools, to prepare students for college level study. The freshman engineering graphics courses should be articulated with the engineering design sequence of courses in the upper division and taught by engineers to provide the necessary design oriented motivation for the student."

It is to be pointed out that in spite of all the training the entering engineering student received in high school in rhetoric, mathematics, and the physical sciences, he is required to take an additional number of hours in rhetoric, mathematics, chemistry, and physics. This is generally not true for graphics. The students have had little or no previous preparation in graphics. Cognizance of these important differences should be taken into account in the structuring of the college level courses, and the credit-hour load for mathematics and physics should be modified and graphics increased.

Chapter III, Item 9, Page 25

The Engineering Graphics Division agrees wholeheartedly with the need for stimulating freshmen engineering courses. This paragraph in the report could perhaps be stated more positively. At the present it reads as follows:

"There are far too few engineering courses at the freshman level to stimulate the entering student and motivate him to continue toward an engineering career. Many feel that the usual course in engineering graphics does not fill this need. Much experimentation is in progress, and much more is needed to develop freshman courses which will have substance and which will provide motivation of the student in the freshman year."

We suggest the following wording:

"There are too few engineering courses at the freshman level to stimulate the engineering student and motivate him to continue toward an engineering career. The engineering graphics courses can provide an excellent opportunity for introducing the student to the field of engineering. These courses should be structured to provide an exploratory experience in engineering methodology that is articulated with engineering design. Much experimentation is in progress, and much more is needed to develop freshman courses that will have substance and which will provide motivation of the student in the freshman year."

We find that too many administrators in engineering education today are not aware of the advanced thinking incorporated in some of the courses in engineering graphics that are being offered in the United States. The work now being done is NOT what was done twenty-five years ago when some of these administrators of engi-

neering education went to school. A significant number of engineering graphics educators are presently experimenting with engineering graphics courses to introduce the concept of engineering decision-making as it applies to analysis and synthesis both graphically and analytically. Therefore, we would appreciate a more positive statement reflecting the opportunities in the freshman engineering graphics courses to expose the engineering student to the engineering profession.

Chapter III, Part C, Item 5

The Engineering Graphics Division agrees wholeheartedly with the statements made in this item dealing with synthesis, analysis, design and research. Many of us in Engineering Graphics Education who have kept in touch with the changing demands upon the engineering manpower needs have modified the course content to reflect the need for developing within the engineering student the identification of creative engineering in terms of analysis and synthesis. The engineering graphics laboratory work has been devoted to the development of cognitive communicative skills rather than the drafting as it existed twenty-five years ago when a considerable amount of time was devoted to manipulative skills.

Chapter III, Part C, Item 7, Page 34

We feel the first paragraph in Item 7 commenting on skills and communication is a very worthwhile statement. It reads as follows:

"Skills in communication -- verbal, graphical and mathematical -- are gained from formal educational programs, from on-the-job experience and, perhaps most important, through off-the-job lifelong learning. Every effort should be made to give the student experience in written and oral expression in all of his courses, for only through continuous practice throughout the college program can the needed improvement be realized. All engineering languages should be utilized -- verbal (oral and written), pictorial and symbolic. Isolated courses offered at the freshman level can be little more than minor extensions of high school courses and are ineffective by comparison with the continuous attention recommended here. The use of graphics as a tool of analysis and of creative thought and also as a pictorial language should be encouraged. The student must be expected to attain and maintain an acceptable performance level in writing, speaking and drawing."

We suggest that the following statement be made to state more definitely the role of the properly structured course in engineering graphics:

"Skills in communication -- verbal, graphical and mathematical -- are gained

Continue on page 35

think negative

7X

MICRO-MASTER 105 mm

Keuffel & Esser Company 127 Fulton St. New York, New York

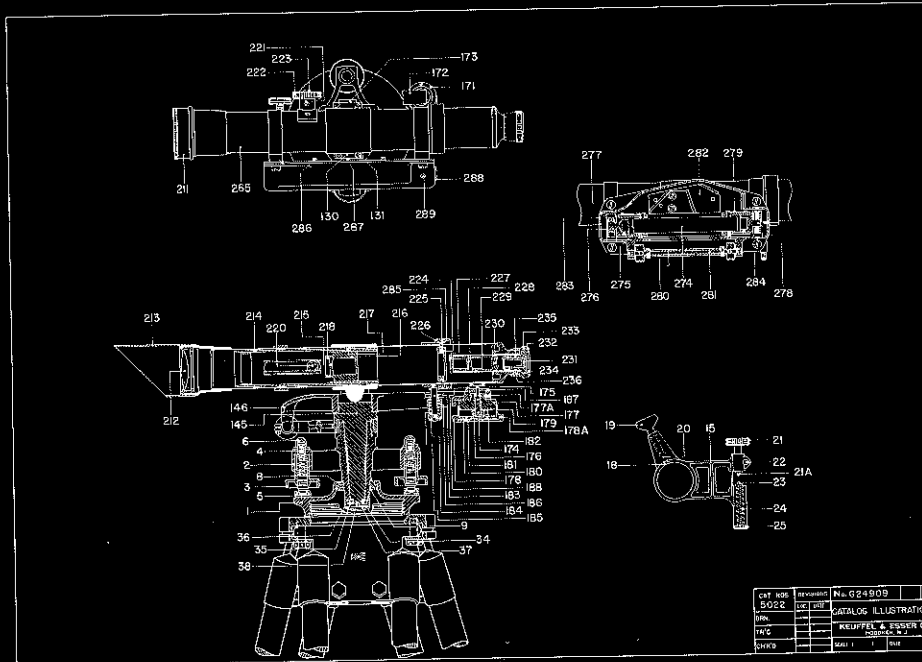

Only the 105mm 4"x6" negative meets the total needs of engineering reproduction

The power of negative thinking!

Formidable, when it's the K&E 105mm negative you're thinking of.

105mm negatives are (you'll excuse the cliché) a breakthrough in engineering documentation. They're one of the products of a system that simply has no peer for versatility. Take full-size prints, for example. Only 105mm lets you project back to original size from the largest drawings with no loss of detail or quality. In fact, they're often improved.

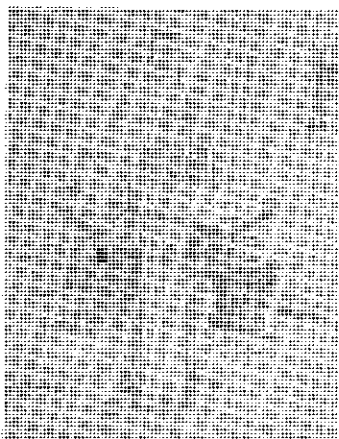

ORIGINAL

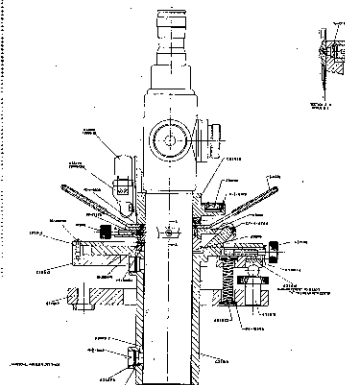

FULL-SIZE BLOWBACK

Lots of people throw away their originals once they have a set of 105mm negatives, knowing they can always produce a perfect second original. You would think twice before trying that with 35mm.

The heart and soul of the 105mm system is the MICRO-MASTER® Camera/Projector shown above. It is a flawlessly engineered reproduction tool with capability in line, continuous tone and halftone—both projection and contact. It takes up less space and costs less (very substantially less) than conventional equipment on the market with comparable capability.

Costs go down, output increases geometrically compared to wall cameras or contact frames for full-size reproduction. Something on the order of ten times faster in filming and developing (and with one man instead of two).

Consider the range of 105mm—efficient, more versatile filming without the need for special expensive equipment... design tool, as in scissors drafting, scale changes and photo drafting... and production tool (directly produces things like printed circuit masters, offset plates and templates)—and you have one of the most exciting propositions to hit engineering reproduction in many a year.

Here, as a sidelight, is what 105mm will do for you in the way of restoring old drawings in bad condition. Crisp, ink-like

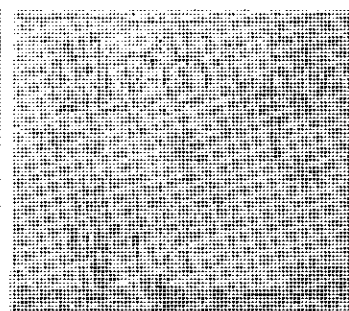
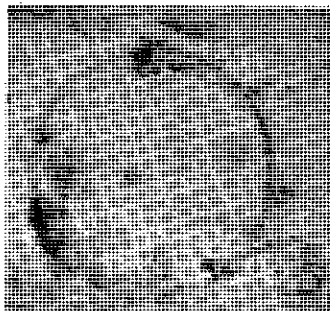

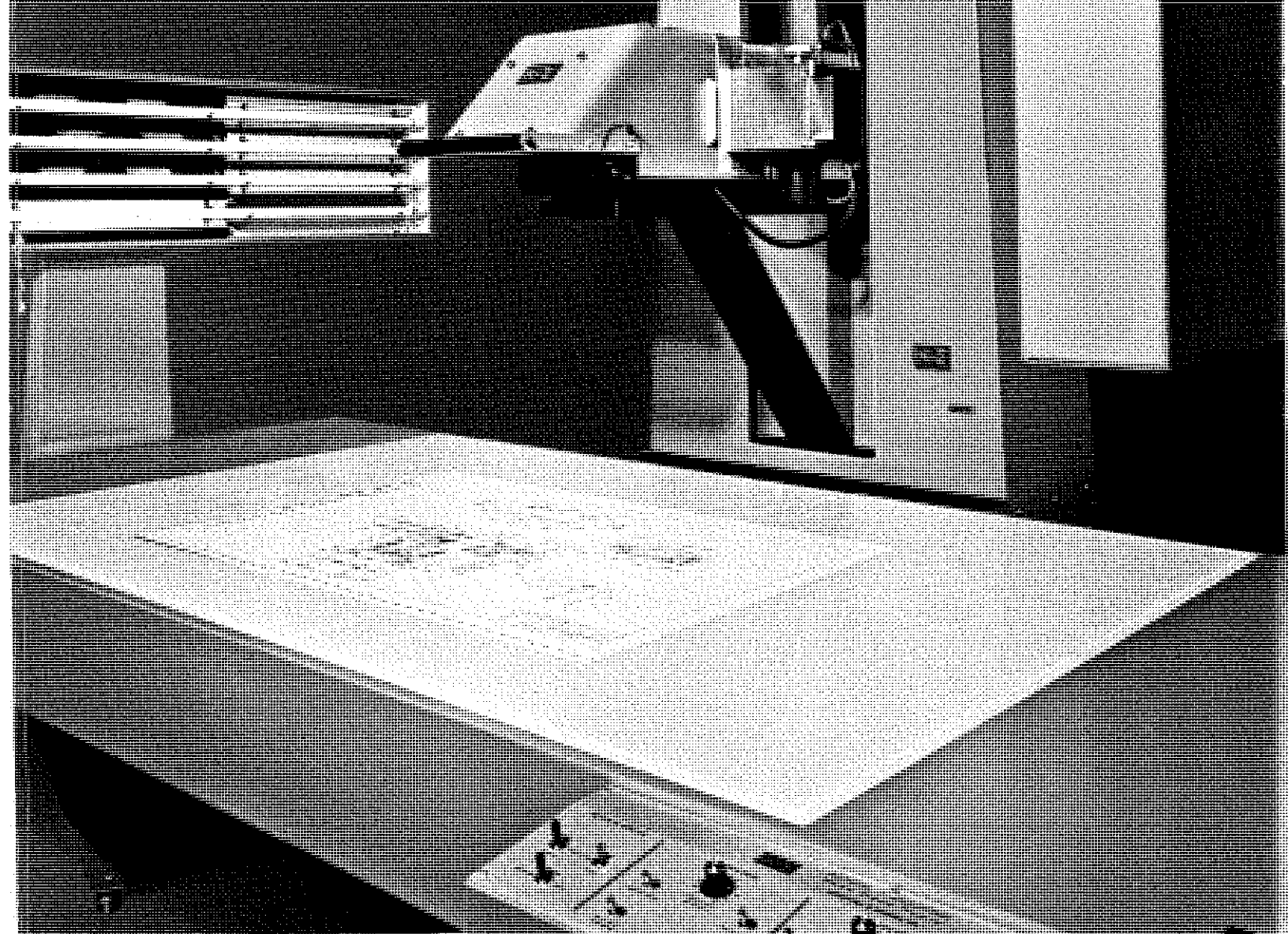

duplicates with 70% of the details automatically removed, which can save you on the order of 90% over the cost of manual redrafting. (Think we're kidding? The British Columbia Telephone Company saved eight times the cost of the 105mm equipment just this way.)

And that's just in its spare time, when it's not effecting economies in other ways.

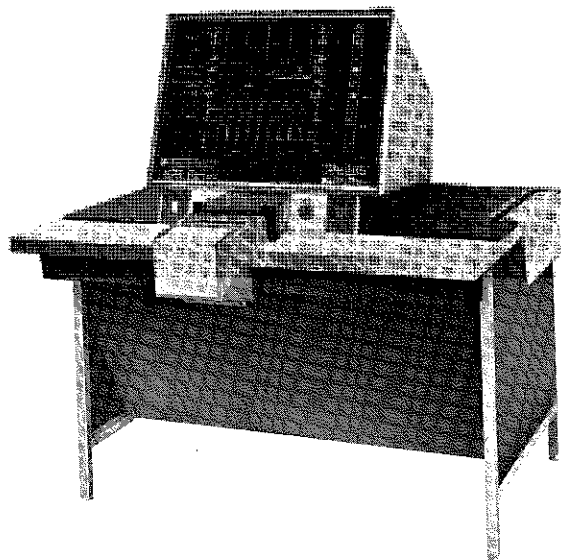

Reference prints are easily and quickly obtained, either from the basic Camera/Projector unit or, even easier from this new Automatic Viewer/Printer. It enlarges 4-times for handy reference viewing, and knocks out 18x24" reference prints in twenty seconds.

Only one company offers the engineering profession the complete system for full range 105mm reproduction capability. Guess who.

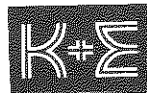

CREATIVE PRODUCTS
FOR THE CREATIVE ENGINEER
KEUFFEL & ESSER CO.

think positive

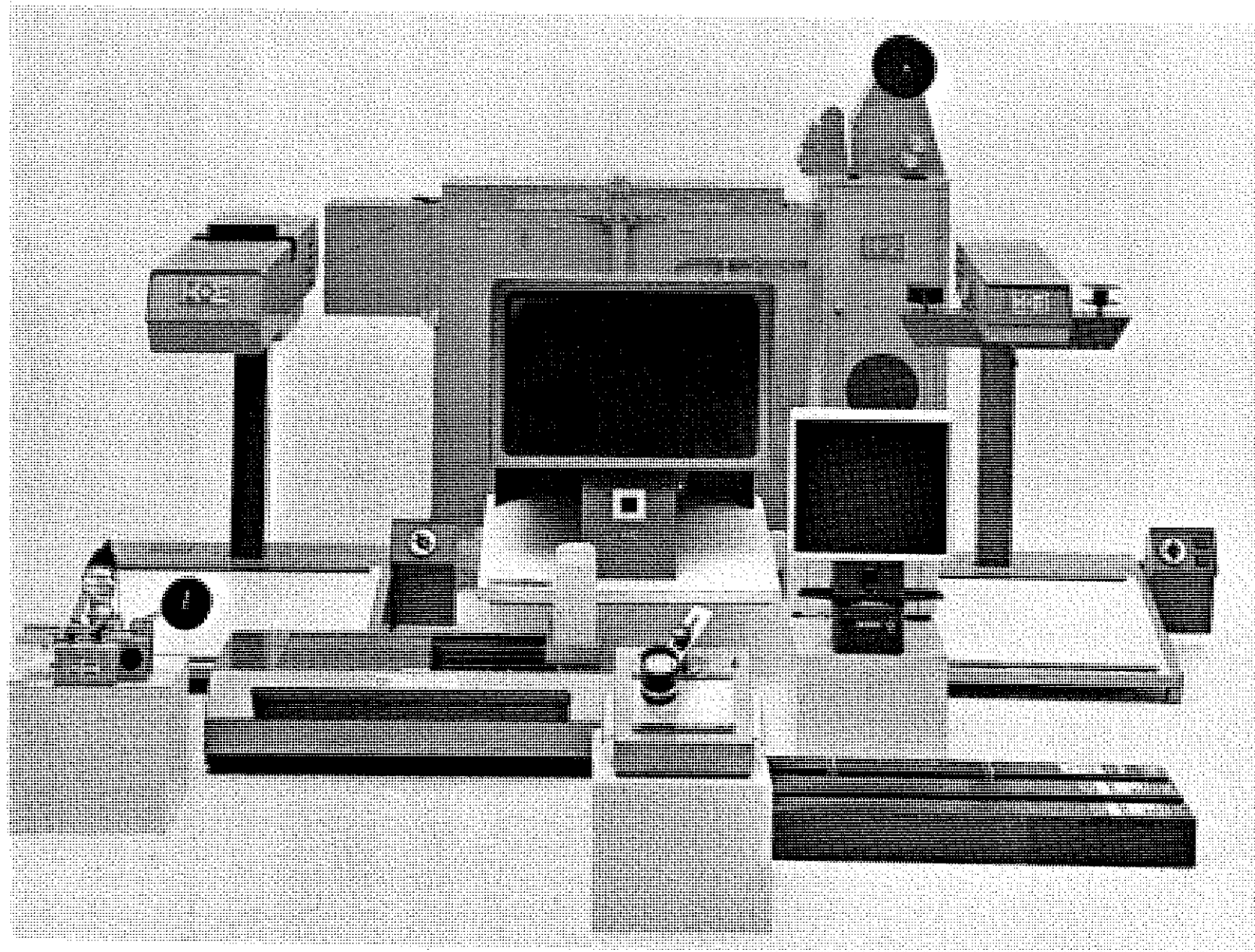

If you like the 105mm story, but know you've got to have 35mm, be a positive thinker and get them both. The MICRO-MASTER Camera/Projector converts easily from one to the other. And we've got all the paraphernalia that goes with both systems—viewers, printers, processors, aperture card mounters, papers, films, cloths. In microfilm as in other areas, total systems. Everything you need to get the job done faster, better, and at less cost. So you can spend less of your time worrying about details, and more on the name of the game, creating.

CREATIVE PRODUCTS FOR THE CREATIVE ENGINEER

KEUFFEL & ESSER CO.



COMMENTS ON THE GOALS REPORT
Continued from page 30

from formal educational programs, from on-the-job experience and, perhaps most important, through off-the-job lifelong learning. Every effort should be made to give the student experience in written and oral expression in all of his courses, for only through continuous practice throughout the college program can the needed improvement be realized. All engineering languages should be utilized -- verbal (oral and written), pictorial and symbolic. Engineering graphics courses should be carefully articulated with the upper division engineering design synthesis courses. They should be structured so as to provide a firm foundation for the use of graphics as a tool of analysis and of creative thought and also as a pictorial language, in the communication of ideas. The student must be expected to attain and maintain an acceptable performance level in writing, speaking and drawing."

CONCLUSION

The Committee of the Engineering Graphics Division charged with the responsibility of developing the report to the initial Information Document No. 3 and the Supplemental Document has worked diligently to bring to the attention of the Goals of Engineering Education Study Committee the objective point of view of the Engineer-

ing Graphics Division on the importance of the inclusion of engineering graphics as a cognitive discipline in the continuum of engineering education. The Engineering Graphics Division does not hold for the manipulative skill-development type of course and has for the past decade actively supported the restructuring of engineering graphics to more adequately reflect the engineering manpower needs. Many independent studies have affirmed the need for the engineer to communicate effectively by use of the graphical language; not only in terms of sketches and drawing, but also in terms of three-dimensional visualization. He must also be able to analyze and synthesize many of his problems graphically which often can be solved more accurately and efficiently by the use of engineering graphics than by other analytical means.

The Engineering Graphics Division has welcomed the opportunity to participate in the Goals of Engineering Education Study and herewith thanks the Goals of Engineering Education Study Committee for their invitation to submit ideas. We respectfully submit the above suggestions and basically feel that a positive statement concerning engineering graphics is much more effective than a negative one.

Respectfully submitted, December 1, 1965

Goals of Engineering Education Subcommittee of the Engineering Graphics Division of the American Society for Engineering Education.

Jerry S. Dobrovolny, Chairman
University of Illinois

Charles J. Baer
University of Kansas

Carson P. Buck
Syracuse University

Edward M. Griswold
Cooper Union

Robert H. Hammond
U. S. Military Academy

Percy H. Hill
Tufts University

Edward W. Jacunski
University of Florida

Herbert T. Jenkins
University of Michigan

Edward V. Mochel
University of Virginia

J. Howard Porsch
Purdue University

Steve M. Slaby
Princeton University

Ernest R. Weidhaas
Pennsylvania State University



BY THE GRAPEVINE
Continued from page 25

A scholarly attitude of self-education should be developed in all students. At the same time, opportunities should be provided for students to work in team groups as well as individually while working out realistic engineering problems.

Student motivation is greatly influenced by contact with people. The incoming college student's idea of engineering is often false or ill-conceived. He is quickly disillusioned by seemingly pointless and difficult courses. Some

students may have been motivated into engineering with grand thoughts of management and high salaries, but find the scholarly grind overburdensome with their supposed goals. The faculty has a responsibility to the student in helping him to define or redefine his goals and to develop a meaningful philosophy concerning the engineering profession.

Contact between the faculty and student must be made early in the student's university life and should be of a continuing nature. This contact

Continue on page 38

the embankment. Line G-D was drawn in a vertical direction to intersect with the extension of Line E-F. Line G-D represents the vertical distance of Point G above the horizontal plane at the bottom of the excavation. The horizontal Line E-F-D is not true length since it is inclined to the picture plane. Line A-G was drawn to be representative of a true slope line parallel to the rivulets formed by drainage. The establishment of this direction, as well as the exact position of the ridge at Point A, was a result of interpretation of the photograph thereby introducing the possibility of an element of error. Line A-C was found by extending Line A-G until it intersected with the horizontal Line C-D which is perpendicular to the face of the foundation. Point C is the point where the slope line of the embankment intersects with the horizontal datum plane. By constructing Line A-H parallel to the lines in the building and the foundation, the 6.5' pole at H was found to be in the plane with the Triangle ABC. Since the undisturbed soil at the top of the excavation was considered to be level, Line A-H was a level line. A scale for measuring the excavation in terms of feet was determined by using the known height of the fence post at H. This scale could be used for the horizontal scale as well as the vertical since the photograph was equivalent to a one-point perspective. The application of this scale to the Triangle ABC yielded a vertical distance of 15.3', a horizontal distance of 15.5' for a 0.987 per cent slope. The distance from the row of fence posts to ridge was found to scale 22 feet.

Emphasis must be placed on the fact that a misinterpretation of the photograph could result in a considerable error, however, it is believed that this error can be minimized to the extent of permitting a usable estimate. An enlargement of the photograph to a size of 15" x 20" or larger would lessen the possibility of error. Interpretation of the photograph is greatly improved if other photographs made from different angles are studied to verify questionable points that may not be apparent in a single photograph.

Regardless of the imperical nature of this method of solving this particular type of problem, it is believed to be the best procedure for estimating the criteria at the given stage of construction. In fact, there appears to be no other way of arriving at a reasonable estimate of the slope and related dimensions after the excavation has been filled. This problem illustrates an extremely unique situation that is indeed rare, however, the information had a value of \$1,000,000. Descriptive geometry principles applied through perspective construction furnished the best vehicle for the problem solution within a reasonable tolerance of error. Descriptive geometry and graphical theories and techniques offer the engineer an alternate approach to many problems that would normally appear to require mathematical or analytical methods. Graphical methods must be understood by the engineer in order that his capabilities can be broadened to permit a greater flexibility in problem solutions, even to the point of saving \$1,000,000 on a single project.



by

Warren G. Lambert, Ph.D.
Associate Professor
Department of Theoretical and
Applied Mechanics
West Virginia University

An accurately constructed one-inch radius circle is very useful for not only the graphic determination of the sine or cosine of an angle, but it is also very useful for the graphic determination of powers of the sine or cosine of the angle and of product combinations of the powers of the sine and cosine of the angle.

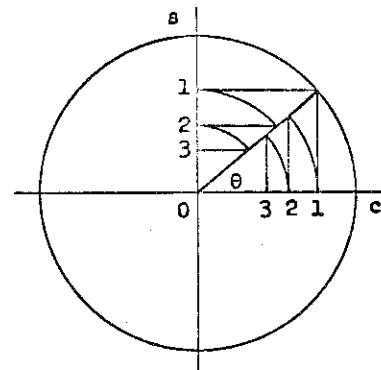

Figure 1. $\sin^k \theta$ and $\cos^k \theta$

Figure 1 indicates the graphical construction required for the graphical determination of the k^{th} power of the sine or cosine; i.e., along the sine axis (s), 0 - 1 is the sine of θ , 0 - 2 is the square of the sine of θ , and 0 - 3 is the cube of the sine of θ , while along the cosine axis (c), the same holds true for the cosine of θ . It is obvious that the construction can be extended for any k^{th} power of the sine or cosine of θ and the value determined by measurement with a scale.

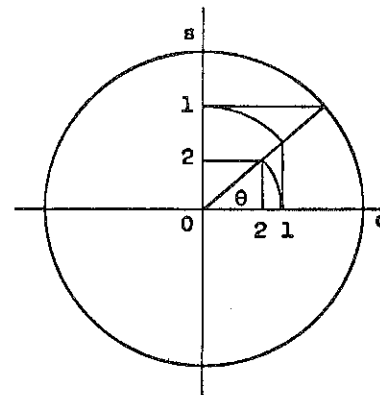

Figure 2. $\sin^k \theta \cos^p \theta$

Continue on page 56

The basics of engineering drawing in light of present-day requirements

FUNDAMENTALS OF ENGINEERING DRAWING, Fifth Edition, 1965

by Warren J. Luzadder, Purdue University. Requiring no prerequisites, the Fifth Edition of this widely-adopted text gives a still more comprehensive coverage of the field, with particular emphasis on basic fundamentals. It contains over 1,200 illustrations, many with surface shading, and incorporates ASA and SAE standards and practices. The following chapters have been written or revised: Tool Design and Tool Drawing; Electronic Drawings, Shop Processes and Shop Terms; Multiview Drawing and Conventional Practices; Auxiliary Views and Basic Descriptive Geometry. Includes a 48-page appendix. 1965, 752 pp., \$10.50

PROBLEMS IN ENGINEERING DRAWING, Fifth Edition, 1966

by Warren J. Luzadder, J. N. Arnold, both at Purdue University, and F. H. Thompson. This new revision of laboratory practice material includes a set of 72 standard problems, presented as partially drawn layouts for your students to complete. Printed on loose sheets of 8½" x 11" manila-type drafting paper and tracing vellum, they allow students to cover the maximum amount of subject matter with a limited time. 1966 72 sheets, \$4.25

WORKSHEETS IN GRAPHIC SCIENCE AND CREATIVE DESIGN

by Morris D. Silberberg and Sandor T. Halasz, both of The City College of the City University of New York. This vinyl care-bound kit provides sufficient material for a full course in graphic science or engineering drawing. The instructor may select plates best fitting his program and objectives, and omit others, without endangering the continuity of presentation. The 95 worksheets are keyed to seven of the most widely-used texts in the field. Unified treatment of orthographic and isometric reading and sketching exercises enables the student to view the problem of space visualization as a whole and not as a group of isolated spots. 1965, 8½" x 11", vinyl case: 11½" x 16¾", \$7.75

BASIC GRAPHICS

by Warren J. Luzadder, Purdue University. The fundamentals essential to graphical solutions and communications. Each basic concept is discussed clearly and in detail, anticipating difficulties commonly encountered by students. Emphasis is on freehand drafting and pictorial sketching and there are over 1,100 illustrations. All material is in full agreement with the ASA standards. 1962, 715 pp., 7½" x 10", \$10.50

(Prices shown are for student use.)

For approval copies, write: Box 903

PRENTICE-HALL, Englewood Cliffs, N.J. 07632

should be made by people who have a good attitude toward students, who can work with them, and who are professionally competent and experienced. Where attrition is a serious problem and student motivation is a prime contributor, university administrators should recognize that additional time must be spent by faculty with students and make salaries commensurate with those of research and administration.

The teacher's role should be one of a consultant who assists the student in evaluating and assessing ideas objectively. The student must be made to stand or fall on his own ideas. To most people the good teacher appears before his class with a well prepared presentation of an integrated series of principles and examples covering a specific area of the curriculum. This teacher has a well prepared plan, an outline within which to work, and has a definite procedure for evaluating the student's absorption of subject content. He has a comfortable feeling that he is contributing in a real way to the student's organized knowledge. The teacher of design, however, can have no absolute plan, outline, or established method of measuring the student's learning achievement. He must resist the temptation to contribute to, or control the student's solution. He must tolerate a novel approach even if it appears impractical. He must evaluate results without prejudice. The teaching of design requires a skill that differs from formalized teaching. He must have the ability to use numerous teaching techniques almost simultaneously.

Early student contact with design problems could provide motivation for otherwise "dull" courses. Instruction in design can be a powerful motivating force to students who are engineering oriented but who know little about the professional duties of the engineer. Design courses can foster closer student contacts with the engineering faculty where analysis and synthesis are integrated in meaningful applications.

The computer and its capabilities should not be ignored in engineering education. However, the computer should not be thought of as replacing a knowledge and proper application of physical laws. Its use should be treated as a tool for augmenting man's effort in solving scientific and data-processing problems.

The computer and its capabilities should not be ignored in engineering education. However, the computer should not be thought of as replacing a knowledge and proper application of physical laws. Its use should be treated as a tool for augmenting man's effort in solving scientific and data-processing problems.

There is evidence that computers are being overemphasized at the expense of other computational methods -- the engineer in industry is not likely to always have a computer available. However, there are a number of current and potential users of computers which go far beyond mere

calculation. Currently, these applications appear to be more in the province of graduate education. One must keep in mind that changes in this status are likely to come. Trivial computer problems should be avoided. The use of the computer should be timely and warranted. The student should learn that the area of analysis is enlarged by means of the computer. Cut-and-dried simulation procedures are made practical, easy, and economical. Computer technology is in its formative stage and new developments are being made at a rapid pace. To base engineering education directly on this field in its current state is unrealistic and would defeat the long-term goals which progressive engineering education needs today.

Improvement can be achieved in any area of engineering education. The value of additional English, speech and other courses can be justified only by motivation and challenging subject matter. Communicative skills, particularly good technical writing and speaking, should be emphasized in every engineering course. An educational procedure which relies on multiple choice exercises, choosing between true and false statements, pure problem solving for isolated answers, proofs in mathematical language, and similar requirements without discussion or explanation of results fails to effectively prepare the engineering student in communication skills.

Engineering education should include a mathematics background compatible with the minimum requirements of practical engineering. Excessive rigor in the early years, teaching mathematics for exercising the brain rather than using mathematics as a working tool -- actually discourages some undergraduates by defeating the purpose of mathematics. Math courses should give the student a competence in application and a knowledge of the utility of mathematics in logical assessment and evaluation of given conditions. Emphasis in mathematics courses should be on teaching the students to use basic mathematic principles in practical analysis and design situations. Students should be exposed to the various advantages of a particular mathematical approach and should learn the limitations under which it becomes useful. Students should learn the subject in sufficient depth to give them a true vision of the power of mathematics as an engineering tool.

Engineering managers report that recent graduates are stronger in mathematics, physical sciences, theoretical principles, and generally more willing to consider new ideas than earlier graduates. However, earlier graduates are viewed as stronger in engineering design, engineering graphics and the ability to solve practical problems.

There are far too few engineering courses at the freshman level which stimulate the entering student and motivate him to continue toward an engineering career. Many feel that a course in engineering graphics alone does not fill this need. All engineering languages should be utilized -- verbal (oral and written), pictorial, and symbolic. Isolated courses offered at the freshman level that are little more than minor extensions of high

Continue on page 60

BRADDOCK LETTERING ANGLES

VERSATILE LETTERING TRIANGLES FOR

SYSTEMATIC
DIMENSIONING
UNIFORM
LETTERING

ACCURATE
SPACING
PRECISE
DRAWING

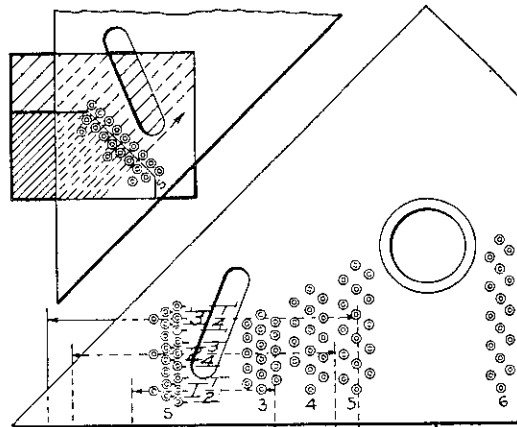

Style "A"

- 5"-60
- 6"-60
- 7"-60
- 8"-60
- 9"-60
- 4"-45
- 5"-45
- 6"-45
- 7"-45
- 8"-45
- 6"-45 Brd.-Rowe
- 8"-45 Style "C"

Style "B"

- 5"-60
- 6"-60
- 7"-60
- 8"-60
- 9"-60
- 4"-45
- 5"-45
- 6"-45
- 7"-45
- 8"-45
- 6"-45 Brd.-Rowe
- Lettering Device

SYSTEMATIC DIMENSIONING

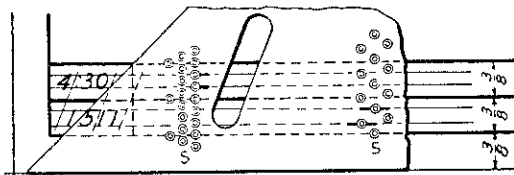

LAYING OUT TITLE STRIP

8"-45 Style "B" Brd.-Rowe

Our Braddock Lettering Angles are designed to give a quick and easy method of making accurately spaced guide lines for lettering drawings, etc. The simplicity of their application permits the subject to be presented accurately and intelligently.

BRADDOCK INSTRUMENT COMPANY

PITTSBURGH, PA.

file to file

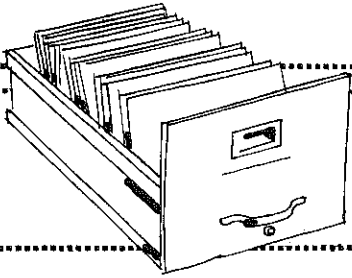

Many "on the line" teachers have ideas, suggestions, techniques, problems, and questions they would like to share with the society. "FILE TO FILE" provides the place for exchange of professional information. If you have an item for exchange, submit it to "FILE TO FILE," E. D. Black, General Motors Institute, Flint, Michigan.

A SOLUTION TO THE "CAN YOU SOLVE THIS PROBLEM"

Proposed in the Spring issue, 1965, The Journal of Engineering Graphics

by

Al Romeo,
Assistant Professor Engineering Drawing
The Ohio State University

7. Project IS to XY on ABC, intersecting OQ at Z.

8. Connect Z with B and T.

The solution to the "Can you solve this problem" as originally proposed in the Spring 65 issue of the Journal of Engineering Graphics and presented by a contributor was an interesting and novel approach. The attached solution, however, is a different approach, and employs more of the traditional

Continue on page 54

A summary of the steps follow:

1. Project ABC to Plane LMND to Identify Plane CDE.
2. Construct CF Parallel to LM.

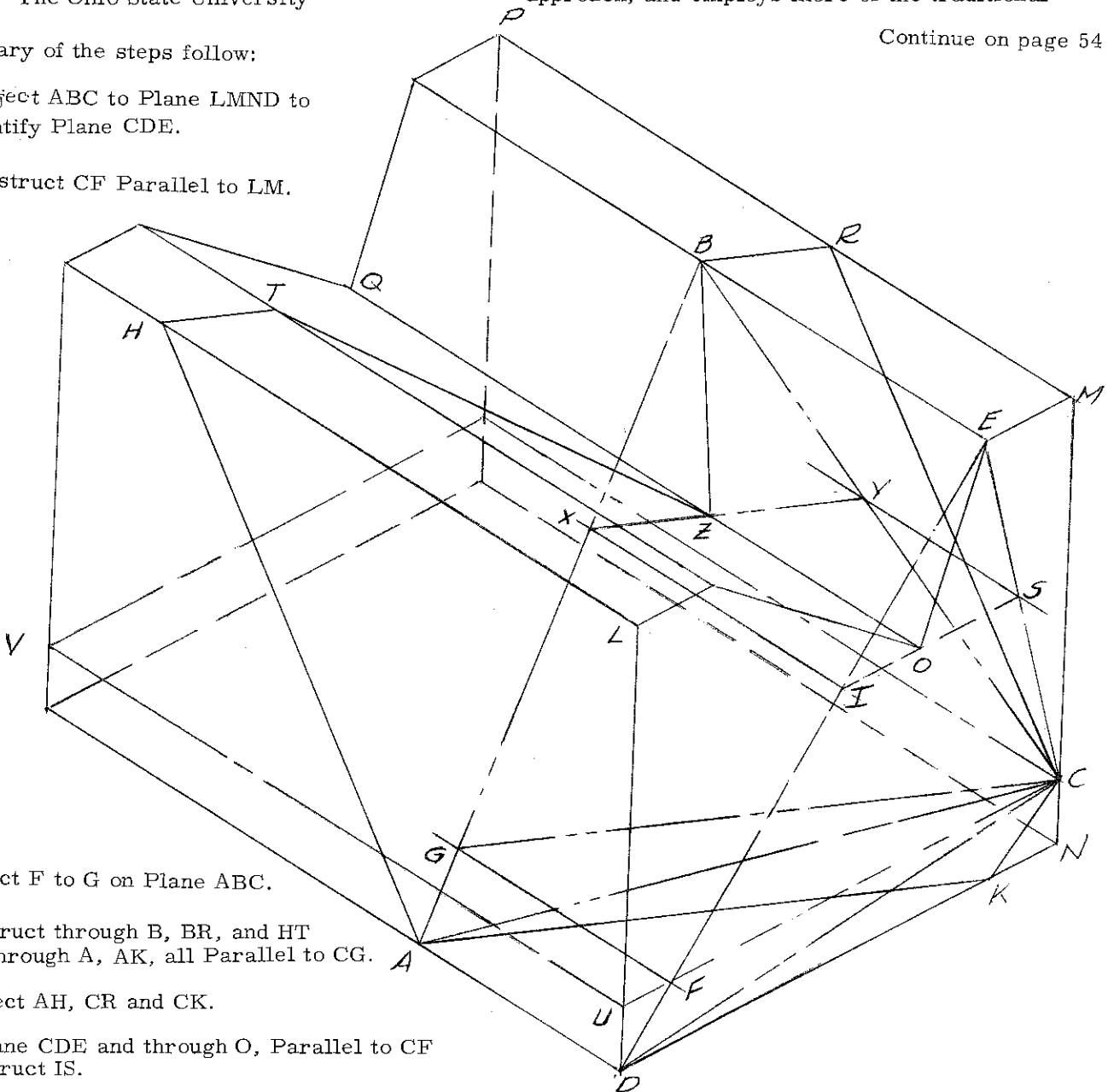

3. Project F to G on Plane ABC.

4. Construct through B, BR, and HT and through A, AK, all Parallel to CG.

5. Connect AH, CR and CK.

6. In Plane CDE and through O, Parallel to CF Construct IS.

*Reflecting the need for a broader
understanding of a powerful design tool*

ENGINEERING GRAPHICS

For Design and Analysis

ROBERT H. HAMMOND, *United States Military Academy*
CARSON P. BUCK, *Syracuse University*
WILLIAM B. ROGERS, *United States Military Academy*
GERALD W. WALSH, Jr., *Jefferson Community College*
HUGH P. ACKERT, *University of Notre Dame*

THIS CLASS-TESTED TEXT BOOK reflects the growing need for a broad comprehension of graphics as a powerful tool in the design process. Its prime purpose is to provide the student with a complete understanding of the role the graphic language plays in the conception, analysis, and communication of ideas. At the same time, the book presents sufficient material to enable the student to understand basic production drawings and to provide the background for the understanding of more complex drawings.

Emphasis is on the theory of projection and on analysis rather than on the techniques and skills required in preparing a production drawing. The development of skill is emphasized as it affects the concepts of accuracy in the use of graphics for analysis. Spatial relationships required for the analysis of three-dimensional problems are presented so that the student can develop his own solution for any particular problem. Numerous step-by-step illustrations supplement the text, and no concept is applied until its theory has been developed for the general case.

A wide range of student problems offer abundant exercises in both representation and analysis. 1964. 534 pp., illus. \$9.50

PROBLEMS — Engineering Graphics For Design And Analysis

Designed for use with ENGINEERING GRAPHICS, this manual provides a full range of graphics problems adaptable to meet most course requirements. The 118 problems are graduated according to difficulty, within five parts, beginning with simple concepts and progressing to those more thought provoking.

1965. 397 pp. \$4.50

The Ronald Press Company.....

..... 15 East 26th Street / New York, N.Y.

MEMORANDUM

You have drawn a card listing the name of an electric appliance or article that has become a standard "best seller" for the average family. Considering that you are employed by a company in the position of design engineer, the boss walks into your office on Monday morning and announces that the product you have designed is beginning to lose sales appeal due to innovations in a similar device produced by your competitor.

You are required to drop all previous product work and concentrate on the design innovation of this product in order to give it new life on the competitive market. Your task is one of coming up with a new twist or improvement on this product in order to enhance its sales appeal. The boss has reminded you that any improvement in the product must not increase the selling price more than ten per cent.

You are required to present your improved product idea including design layout drawings, calculations proving workability, and cost breakdown before company executives on Wednesday, April 7, 1965 at 2:30 p.m.

Class time during this assignment is devoted to "executive sessions" where each idea is discussed in brainstorming sessions, feasibility and cost of new products debated, and an industrial designer invited to class when new ideas are sounded out. After five weeks of class discussion and outside work, solutions and prototypes (constructed in the Tufts Design Laboratory) are presented in critique.

THE CASE STUDY

TUFTS UNIVERSITY
DEPT. OF ENGINEERING GRAPHICS
AND DESIGN

Date -----

MEMORANDUM

To: E. G. D. 22, Design Group
From: P. H. Hill, Chief Engineer
Subject: High speed transportation system for the
Boston to Washington D.C. Corridor.

There is a great need at the present time and an urgent need in the future for an all-weather, ground-level passenger transportation system from Boston Mass. to Washington, D.C., following a route to be known as the Northeast Corridor. This is a 460-mile route along the Eastern seaboard between Boston and Washington which embraces the nation's most heavily unbroken populated area, coupled with a virtually consistent corridor of manufacturing and industrial activities. The Department of Commerce is engaged in a program to upgrade and realize passenger trans-

portation service along this corridor, or as Senator Claiborn Pell (D. -R.I.), the godfather of the plan calls it: the "megalopolis."

This proposal was brought to light in President Johnson's State of the Union message. The President's plan calls for a three-year research and test program, an initial \$20 million outlay the first year. The long range research program could extend over the next decade and a half. However, the demonstration project could come into being next year.

As currently visualized, some \$10 million will be spent for research and development of new ground transportation systems, about \$8 million for demonstration projects, and \$2 million for statistical studies.

The E.G.D. 22 DESIGN GROUP is hereby assigned the task of performing basic research studies for such a transportation system to meet the demands stated in this memorandum, to undertake feasibility studies on available systems, and to produce an initial design study of a basic system to form the basis for a proposal to the government for a contract to produce a workable design of the transportation system for the Northeast Corridor.

Our operating plan is to work as a group during the initial phases of investigation and then divide into subgroups for concentrated design of subsystems. Each subgroup leader will report directly to the instructor (chief engineer) as coordinator of the project. Our task is one of proving the feasibility of a specific system of transportation and producing preliminary design studies that can be defended in critique before invited government officials, the latter part of May of this year.

With our present knowledge of transportation systems that are capable of producing safe high-speed passenger service, it is evident that the system involving a vehicle in a tube, invented by Dr. Joseph V. Foa, Head of the Department of Aeronautics and Astronautics, Rensselaer Polytechnic Institute, is the most feasible. This conclusion is supported by the results obtained from the Tokaido Line, operated by the Japanese National Railways between Tokyo and Osaka where they operate at speeds in excess of 150 MPH. This conclusion is also supported by monorail systems as used in Seattle, Washington, and Houston, Texas, and the magnetically floated vehicles being investigated by Westinghouse Electric Corp.

Our first task shall therefore be the investigation of the possibility of transporting a vehicle in a tube, which hereafter we will identify as:

TUBE FLIGHT

FURTHER INSTRUCTION

Additional data and research studies will be distributed as the design investigation develops.

Continue on page 46

THE NEW Ames Lettering Guide...

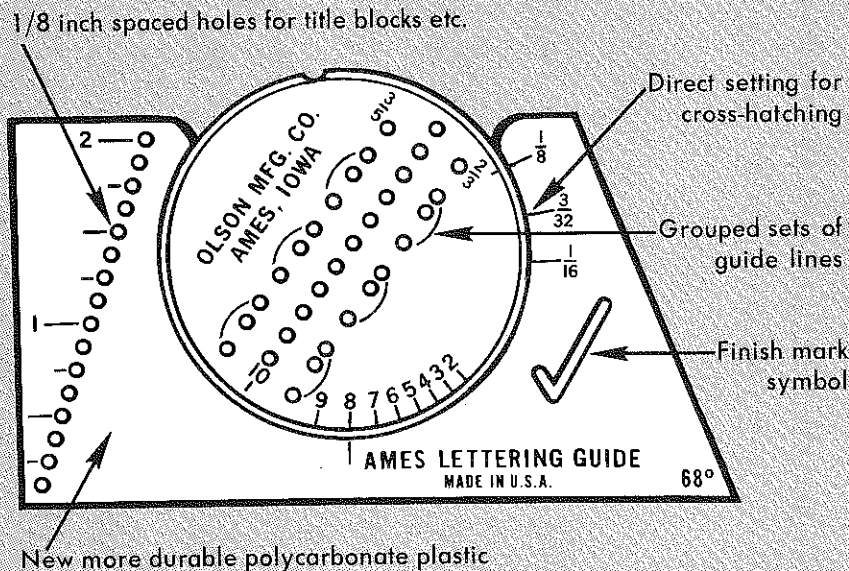

NOW WITH SEVERAL ADDED FEATURES

We would be happy to send a free new Ames Lettering Guide to any instructor. Write us on your departmental letterhead and it will be forwarded immediately. After trial and evaluation, we feel sure you will recommend it to your students.

OLSON MANUFACTURING CO.
P.O. Box 109 • Ames, Iowa
"Drafting Products by Olson of Ames"

Available through jobbers, distributors and dealers of drafting equipment everywhere.

OFFICERS PAGE

Continued from page 6

trained personnel, bifurcation and multifurcation of engineering degrees will be initiated. Graphics role will be in the basic subjects that will form the engineering core, along with mathematics, physics, chemistry, English, history and the humanities. How much time will be allowed; its importance to degree granting departments; the amount of coverage and what should be covered in graphics are contingent on the educational and regional objectives of individual institutions. Where one institution enrolls students who never before held a T-square in their hands and must begin with courses in basic fundamentals; another may have selective enrollment and can indulge in advanced courses in graphics or teach one, or several courses that have been developed as valuable graphics by-products during the past few years. The graphics sequence, therefore, will vary from school to school and coverage will be influenced by departmental demands, time limitations, and faculty capabilities. Its emphasis can be pictorial, quantitative, symbolic, mathematical or graphical. No one individual school can say that its presentation is the answer to another's. Our technological advances have so expanded that graphical knowledge, like all knowledge, has newer and broader horizons. The fact that in recent years graphics has been put to the test has worked in its favor. The chaff in course content has been

eliminated and the entire field of graphical communication has acquired vigor and substance and scope in coverage. Of importance should be the realization that the field of graphical communication has expanded into a sequence of graphics courses rather than one. The sequence starts with basic Engineering Drawing and goes on through Computer Graphics and beyond to sophisticated industrial applications.

Recognition as a basic engineering subject, and adequate time in which to teach graphics, are of immediate concern in importance, and calls for immediate action. Subject coverage and the extent of coverage are contingent on both. Lacking these the graphics teacher can only do the best he can, in the time he has and not lose his dedication in his beliefs.

Graphics, therefore, is a patient and its faint heartbeat has been quickened by helpful references to its future status in the Goals Report. These statements, however, are not the miracle drugs that will restore the patient to overnight health. Diagnosis of the patient's many ailments and the prescription for proper medication is the challenge that lies before the Division of Graphics and its individual members. Graphics has been a wheelchair patient too long and may continue to remain as such unless there is an immediate call for a doctor in the house --!

March 30, 1966



THREE-PRONG U-BAR AND CARRYING CASE

By

William F. Carpenter, Chairman
Mathematics Department

and

H. W. Blakeslee, Instructor
Technical Education Department

of

Central Florida Junior College
Ocala, Florida

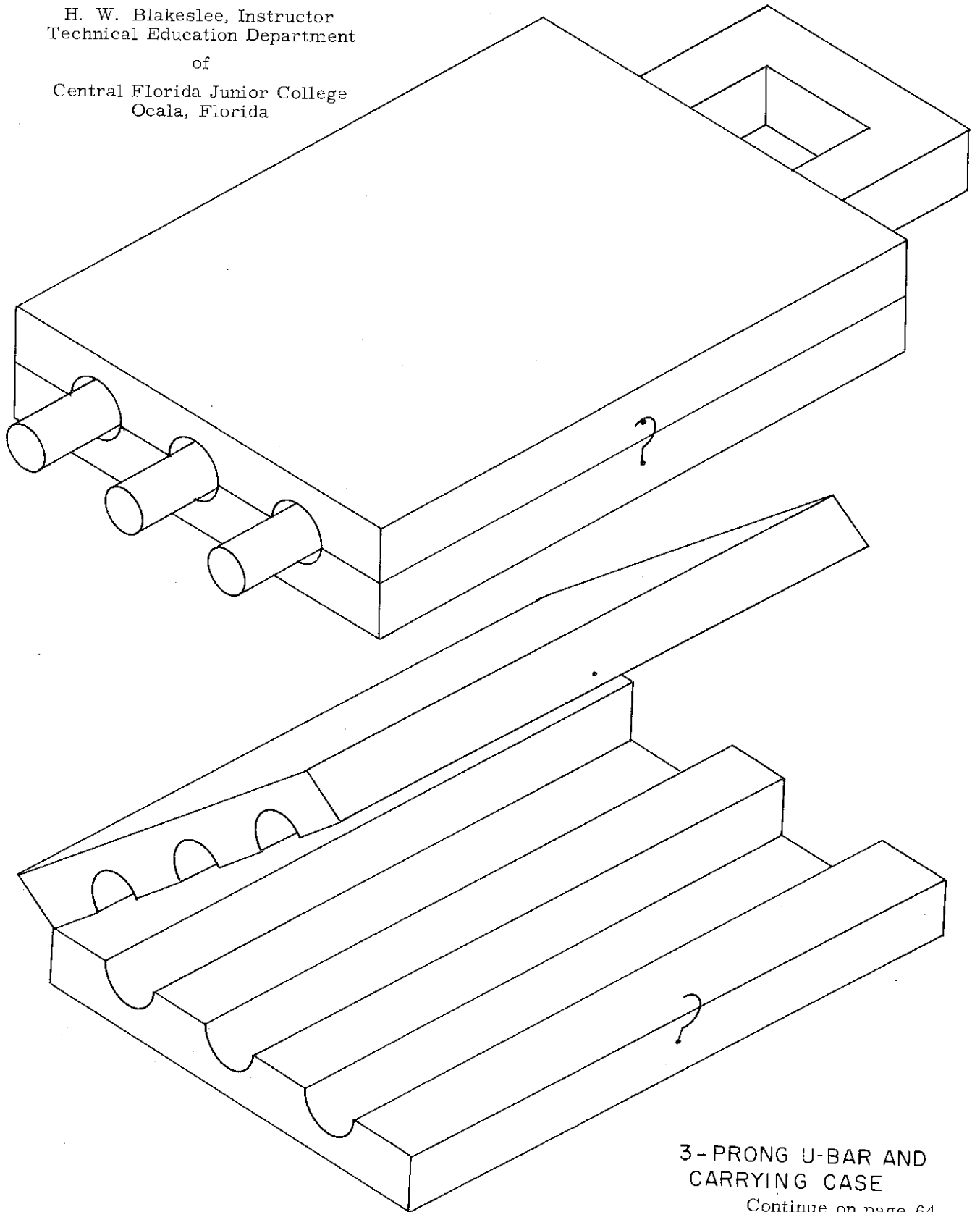

3-PRONG U-BAR AND
CARRYING CASE
Continue on page 64

4

important

books

in the field

from...

Barnes & Noble

1. Engineering Descriptive Geometry

78 Examples with Complete Solutions. 139 Problems including Answers or Suggestions. Diagrams Drawn to Scale on Cross-Section Paper.

by *Steve M. Slaby*. "The style is simple and uncomplicated. It is geared to the needs of the average college student and is well organized. Drawings are unusually clear, uncluttered, and admirable in every way. . . . It would make a welcome addition to the shelves of the high school teacher of solid geometry."--*Mathematics Teacher*

"Presenting the basic principles of descriptive geometry in clear, annotated pictorial representations followed by graphic examples."--*Science News Letter*

Paperback \$2.50

2. Engineering Drawing

Basic Principles and Rules with Problems & Tables
ASA Standard Drawings & Drafting Room Practice

by *Lombardo, Johnson, Short and Lombardo*. "The purpose of this text is to provide a comprehensive, practical guide that will aid the student to master the essentials of engineering drawing. The text is designed to introduce him to develop working skill and efficiency."--*Design News*

"Should prove useful not only to the student, but also to the engineer wishing to refresh his memory on a particular point."--*Engineering Journal*

Paperback \$2.50

3. Technical Writing

A Guide to Manuals, Reports, Proposals, Articles, etc., in Industry & the Government

by *Richard W. Smith*. Written for the embryo technical writer with heavy emphasis placed on the industrial aspects of the subject giving broad application to the engineering field. It includes -- useful chapters on "The Mechanics of the Trade," a comprehensive bibliography; an appendix entitled "Are You Ready to Write" offering review examination that covers basic grammar rules and skill in expository writing, with answers and explanations.

"It's an excellent summary of the whole field, which includes many areas of technical writing that most books neglect."--*James Stokley, Michigan State University*

Cloth \$3.50; Paperback \$1.25

4. Thinking With a Pencil

With 692 Illustrations Showing Easy Ways to Make and Use Drawings in Your Work and in Your Hobbies

by *Henning Nelms*. This work begins with drawings which are so simple that they require no skill at all. Each chapter prepares the reader for the next and at the same time provides an effortless review of the material already studied. The reader learns to draw by making drawings that he can use. The formal practice required by other approaches to drawing is almost entirely eliminated.

"In my opinion your book would definitely be a valuable addition to any engineering student's library. Any medium which helps an engineer to convey his ideas to another person is without question a vital and necessary part of an engineer's education."--*Steve M. Slaby, Princeton University*

Cloth \$4.95; Paperback \$1.95

Free examination copies of paperbacks are available to instructors

Barnes & Noble, Inc. 105 Fifth Avenue, New York 3, N.Y.

Continued from page 42

This design is conducted on a team basis to give the student an experience with "group dynamics." After several sessions devoted to discussions centered on the development of Task Specifications, the class is divided into the following teams in which each team elects a Project Engineer responsible to the Chief Designer (engineer).

Experiment and Research Team -- Responsible for the reduction of the theory of tube flight to practice through experimentation on a scale system for the purpose of advising other teams on speeds attainable, weight of vehicle, etc.

Vehicle Team -- Responsible for the complete design of the vehicle including enclosure, seating, control console, environmental interior system, safety devices, and a study of the number of passengers to service population centers which will include the cost of operating the system based on passenger miles.

Propulsion Group -- The complete design of the propulsion system including basic engine; fuel system; controls; auxiliary power for lighting, air conditioning, and heating; and braking system.

Structural Team -- The complete design of the structure including the selection of the route for express and local runs; design of the tube, bents, trusses, and footings; methods of switching (branching) for exit and entrance on local runs; concept of station and vehicle storage.

Project Engineer (Each team) -- The Project Engineer will report directly to the Chief Designer and shall be responsible for the assignment and coordinating of design activities within his group, cooperation with representatives of other teams so that final design will have continuity, supervision of drawings and written material for the final report, and organization of the presentation for critique for his team or group.

The use of the case-study method in teaching mechanical design is an effective means of involving students in realistic design situations. The contrived case study is fictional and related to an area the instructor wishes to emphasize, while an authentic case involves a series of visits to a local industry to gain background material on which the case may be written.

The TUBE FLIGHT is an example of a typical case study assigned to students.

DESIGN CRITIQUE

Each student is required to keep his design work including a progress report, task specifications, concepts, and all analysis calculations in a computation book that is available for inspection at any time during the design period and at the time of critique. The final solution must include a letter of transmittal, written description of the

workability and feasibility of the device, cost breakdown, and design layout drawings. Each student is required to present his solution before a design jury consisting of four invited professionals (usually from industry) who interrogate him on the feasibility and workability of his solution. The design jurors rate each student on his presentation which augments the instructor's evaluation of the design report and aids in determining the student's grade in the course.

CONCLUSION

The course described here, at the senior level, combines the student's four years of study into a single experience where discipline learned must be applied under realistic engineering situations. Such a course allows a student to express himself as an individual and does not suppress his creative urge. (The student assumes an active role in his education, possibly for the first time.) That the results of this experience have been most rewarding has been evidenced by the student's progress in industry after graduation and his independence with thesis work while at Tufts.

RELEVANCE TO ENGINEERING GRAPHICS

We at Tufts are now instructing freshman students in engineering graphics with related emphasis in engineering design. We are experimenting this year and will change our course next year to an inversion of this approach, namely, instruction in engineering design with related emphasis on engineering graphics. The course will involve students in Design Case Studies, about six over the period of a year. Each project will occupy about six weeks of a student's time. Engineering graphics will be taught on a "need to know" basis as topics arise during the course of the case study. We believe we can teach communication of ideas and graphical analysis through active student involvement on realistic design situations chosen to illustrate the major fields of engineering. We feel that the course will accomplish the following objectives:

1. Students' active involvement in education as opposed to passive.
2. Involvement in realistic design situations.
3. Involvement in engineering graphics as a communication and analysis tool.
4. Practice in written and graphical skills through design reports.
5. Practice in inductive reasoning through open-end projects.
6. Introduction to major fields of engineering through design projects.
7. Involvement in the Design Process with emphasis on the conceptual phase.

Continue on page 56

Mr. Bruning's more expensive sepia paper pays off every day at 5!

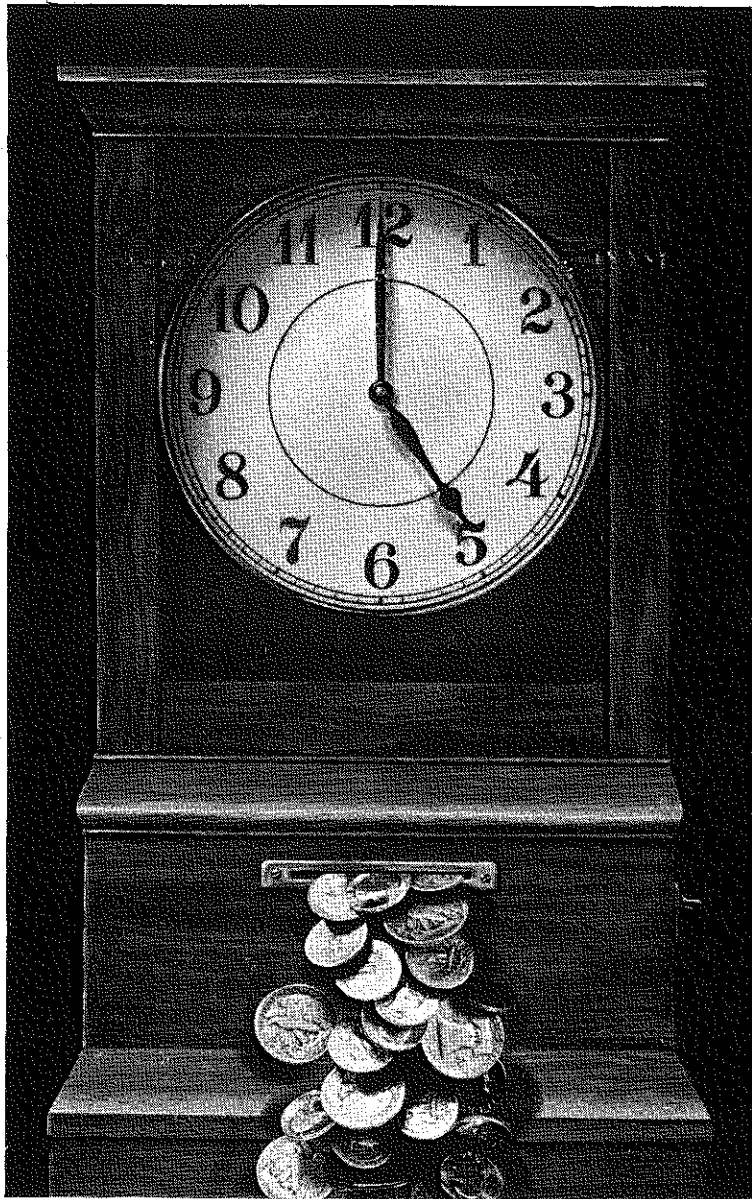

Why? Because it's from 28 to 52 percent faster than any other paper you can use.

And faster sepia pay off in three ways:

1. Faster papers mean less operator time at the machine.
2. Faster papers mean increased production.
3. Faster papers give your operators much greater latitude in operating conditions to produce perfect prints. Wastage takes a nosedive.

Because Mr. Bruning's new sepia paper is so much faster, your operator can often switch from making blue-line prints to sepias without having to adjust machine speed.

What else do you get? Superior drafting and eradication qualities. If you haven't tried Mr. Bruning's faster sepia, you'll be surprised at its ability to take pencil or ink revisions—and then maintain high legibility through various generations of prints.

Are we knocking our less costly sepia? Not one bit. It's a top-quality paper in its own right—just not as fast. Moral: people interested in profits buy value, not just price.

The Bruning man will stand behind everything we've said. Make him prove it—with a demonstration in your own shop. Give him a call. By now, you probably even know his home phone number.

 **Bruning**
DIVISION OF
ADDRESSOGRAPH MULTIGRAPH CORP

NUMERICAL CONTROL DRAFTING

Continued from page 19

The next group of applications illustrates N/C continuous path drafting as a method to graphically portray the solution to computer-aided design problems. Figure 8 shows the graphical solution to a problem to determine the proper fit between the turbine blade dovetail and turbine wheel serration based on permissible looseness in the assembly. Manual drafting techniques would require much more time here than the previous example (Fig. 7) because of the irregular curved surfaces.

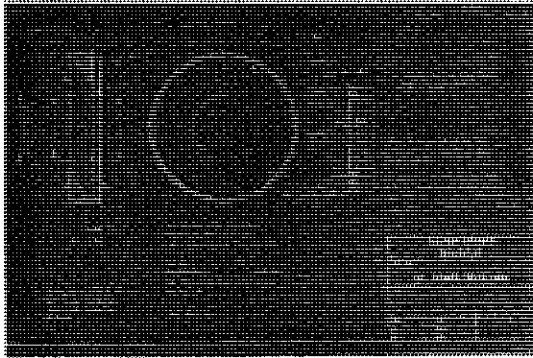

Spline Gage Drawing

Figure 7

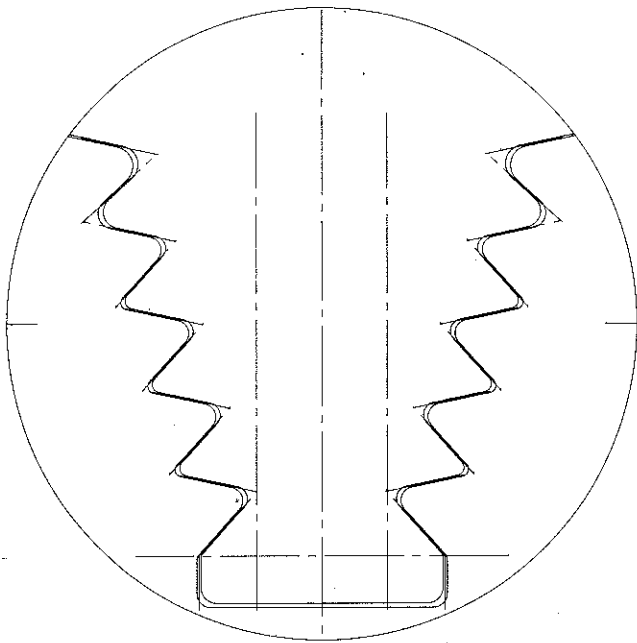

Turbine Blade Dovetail Fit

Figure 8

Evaluation of a gear tooth design by a computer is illustrated in Figure 9. Mating teeth characteristics shown are: (1) distance overpins, (2) pitch diameters, (3) minimum and maximum tooth form,

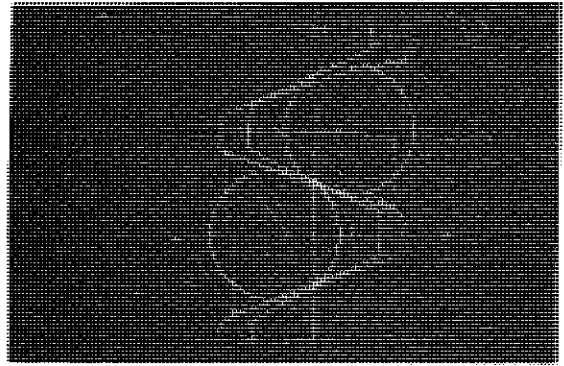

Gear Teeth

Figure 9

(4) stress parabolas for load at the tip and mid-point of the tooth, (5) tooth spacing, and (6) backlash check. This represents a good example of the integration of N/C and design. The time required to determine all the listed characteristics would be much greater if manual calculation and plotting techniques were used. Figure 10 shows a drawing of an entire special form gear including the pitch diameter. The Allison Research and Engineering Journal, Volume 6, Second Quarter, 1965 has a good article on N/C drafting.

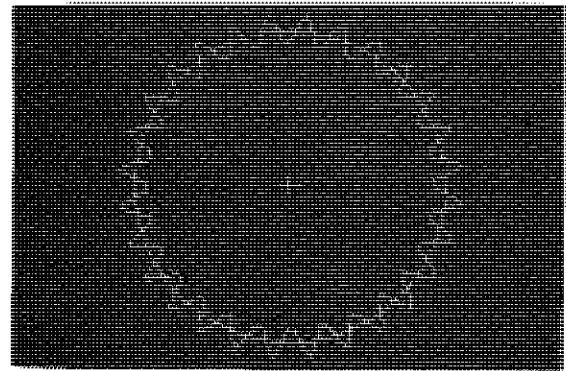

Special Form Gear

Figure 10

The examples of N/C drafting applications represent only a few of the possible uses for this type of equipment. A variation of N/C drafting is General Motors DAC-I (Design Augmented by Computer). The DAC system permits use of the computer to assist in design utilizing mathematical equations or by accepting and reading a drawing with free-form curves. Additions, deletions, or changes can be made instantly with the modifications projected on the screen in graphic form. The system is also capable of producing hard copy drawings for engineering use. This feature duplicates many features of an N/C drafting machine. An interesting article explaining the DAC-I system is in the General Motors Engineering Journal, Volume 12, Number 2, Second Quarter, 1965.



FIVE TESTED TEACHING AIDS FOR ENGINEERING DRAWING



BY CARL L. SVENSEN AND WILLIAM E. STREET

FOR USE WITH ANY TEXT OR NO TEXT

DRAFTING PROBLEM LAYOUTS

SERIES D, REVISED 1962

Work sheets covering Vertical and Inclined Lettering, Sketching, Use of Instruments, Engineering Geometry, Scales, Orthographic Projection, Revolution, Auxiliary Projection, Sections and Conventions, Isometric, Oblique, Dimensioning, Developments, Intersections, Screw Threads and Studies of Points, Lines, and Planes.

100 Work Sheets, 8 1/2" X 11" _____ \$3.50

DRAFTING PROBLEM LAYOUTS

SERIES C, REVISED 1964

Work sheets covering Vertical and Inclined Lettering, Sketching, Use of Instruments, Engineering Geometry, Scales, Orthographic Projection, Revolution, Auxiliary Projection, Sectional And Conventions, Dimensioning, Screw Threads and Bolts, Isometric, Oblique, Perspective, Developments, Intersections, Working Drawings.

95 Work Sheets, 8 1/2 " X 11 " _____ \$3.50

LETTERING EXERCISES

A DIRECT METHOD - NEW AND INTERESTING

Vertical and Inclined Lettering with eight sheets of extra problems.

20 Work Sheets, 8 1/2 " X 11 " _____ \$ 1.00

VERTICAL LETTERING EXERCISES

Vertical Lettering with instructions

6 Work Sheets, 8 1/2 " X 11 " _____ \$ 0.50

INCLINED LETTERING EXERCISES

Inclined Lettering with Instructions

6 Work Sheets, 8 1/2 " X 11 " _____ \$ 0.50

WRITE FOR EXAMINATION COPY OR ORDER FROM

W. E. STREET
ENGINEERING DRAWING DEPARTMENT
LOUISIANA STATE UNIVERSITY
BATON ROUGE, LOUISIANA

Prepare your own problem book by selecting your drawings from these books in quantities of 25 or more of each layout.
Allow 90 days for order.

Computer-Assisted Programming for
Numerical Control Machines

To this point, nothing has been said about the procedure required to calculate or determine the information that goes on the tape which controls an N/C machine. This function is called programming, and the job is done by a person called a part programmer. This differentiates from a computer programmer, whose job is to program computers.

A part programmer for an N/C machine is a person whose job is to determine the sequence of operations by which the machine tool produces a part. This usually requires selecting the cutting tools to be used, feed rates, spindle speed, and the sequence of operation or successive passes over the workpiece. A process engineer is frequently used for this job. For positioning machines, programming is often accomplished manually. When contouring is required, it is necessary to use a computer to assist in determining the thousands of points needed to generate a surface. From the previous examples of drafting applications, it is also evident that many engineering problems can be solved by computers. This is where design and N/C can be integrated which was listed among the advantages of N/C applications. The solution to a particular problem by computer, graphical representation using an N/C drafting machine, and finally the production of a part on an N/C machine tool is a logical method of approach to engineering. If a design, drawn by the drafting machine, is not deemed desirable because of error, miscalculation, or oversight, it is easier to make the corrections before proceeding with a project that will inevitably become a "white elephant." Often only certain portions of a part need revision.

One computer-aided system which is used in industry and is applicable in engineering education is the APT (Automatically Programmed Tools) system. APT is particularly useful in engineering education because it: (1) utilizes the student's background in analytic and solid geometry (it applies mainly to surfaces definable by an equation), (2) is basically Fortran programming and relatively easy to learn, (3) can be used for two- or three-axis parts, and (4) will be available to educational institutions at "no charge" for instructional purposes in the near future.

An example of how APT can be used in engineering education is the following example. Shown in Figure 11 is a simple two-dimensional cam shaped part composed of three radii and a tangent line. Figure 12 shows what the APT system sees or recognizes in the part definition (three 3 complete circles and one 1 line).

Symbols designating each surface have been added and four (4) APT statements will define this part as follows:

```
CIR1 = CIRCLE/0,4,1
      (Circle No. 1 has its center at
       X=0, Y=4, and has a one-inch
       radius)
```

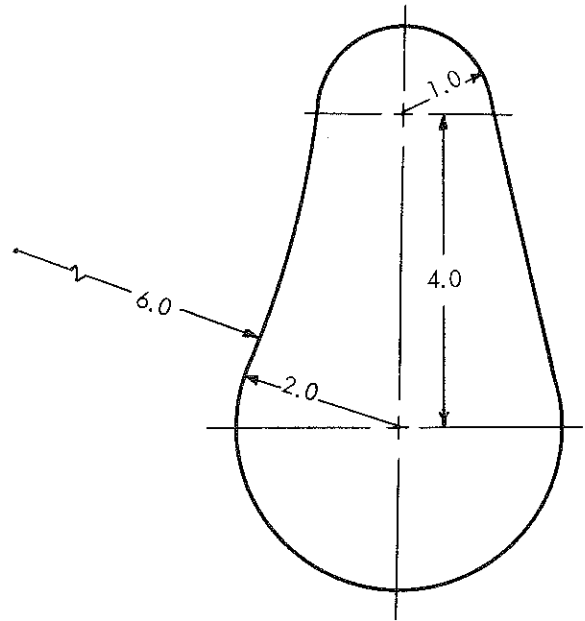

Part Specification
Figure 11

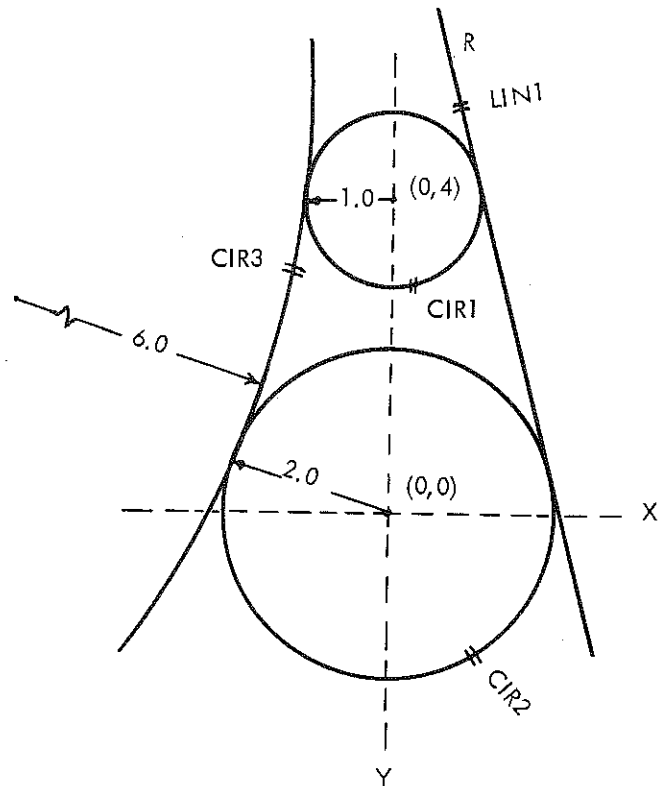

APT Surfaces
Figure 12

DRAFTING TRENDS

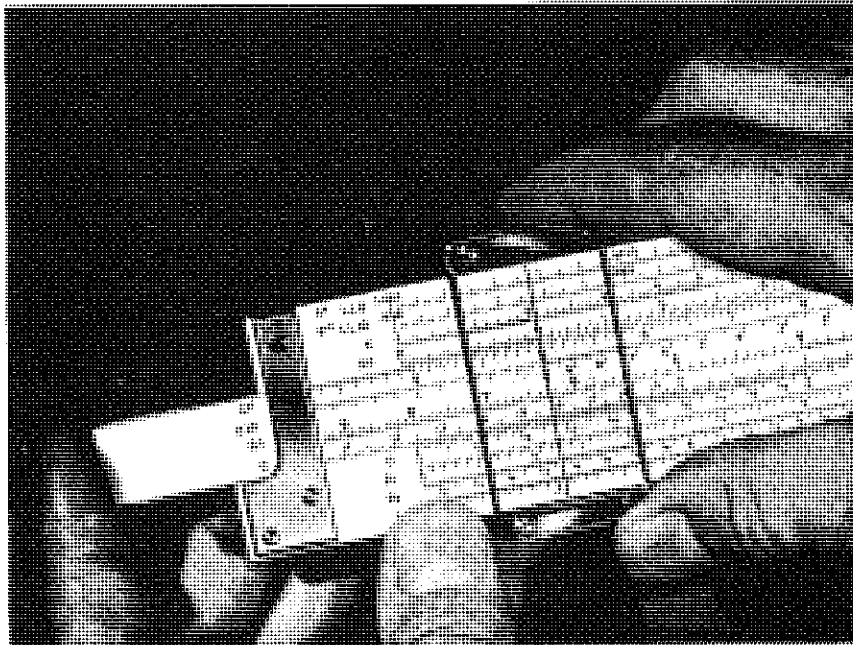

The POST Versalog is a modern slide rule that will do more work for you.

How modern slide rules save time, give greater accuracy

New, modern slide rules have been developed to keep pace with modern engineering mathematics. Vastly-improved scales and scale arrangements—plus easier-to-read graduations—speed calculations, eliminate errors, and offer greater accuracy.

Are you restricted by your slide rule's limitations?

Your present slide rule may be slowing your calculations to horse-and-buggy speeds. Minutes wasted each day can amount to many hours each year. If you are not making use of the time-saving short cuts offered by up-to-date POST slide rules, it will pay you to investigate. They offer smooth, effortless operation for an entire lifetime. The time-tested POST laminated bamboo construction is resistant to dimensional changes and swelling. Graduation markings are cut into the rule faces with watchmaker precision.

Which slide rule will do the best work for you?

The POST Versalog, developed by professionals for professionals, has

exclusive color-coded trigonometric scales; better scale arrangements offer greater speed; square root and log-log scales permit more accurate readings. The POST Versatrig is ideal for those who need a comprehensive trig-type rule, but do not require a log-log rule such as the Versalog. Drafting supervisors can recommend the Versatrig to draftsmen, technicians and specialists, confident that it is the best slide rule for their use.

POST offers other 10" slide rules, 4" and 5" pocket models, circular slide rules, Chem rules and frequency response rules. All have a lifetime guarantee and complete instructions.

Free information

To learn which slide rule will do the best work for you, consult the POST selector chart at your dealer's or write for free slide rule literature to Frederick Post Company, 3664 N. Avondale Avenue, Chicago, Illinois 60618.



engineering and
copying products

CIR2 = CIRCLE/0,0,2
 (Circle No. 2 has its center at X=0, Y=0, and has a two-inch radius)

LIN1 = LINE/RIGHT, TANTO, CIR2
 RIGHT, TANTO, CIR1 (Line No. 1 is tangent to Circle No. 1 and Circle No. 2 on the right going from CIR2 to CIR1)

CIR3 = CIRCLE/X SMALL, OUT, CIR2,
 OUT, CIR1, RADIUS, 6 (Circle No. 3 is on the X small side of CIR2; and tangent to both Circles No. 1 and No. 2 with a six-inch radius)

Changes in design can be accomplished by changing the definition statements. Note also that Circle No. 3 does not need to have its center located in order to have the arc generated by drafting or machining. For ease in definition, the X and Y axes were located arbitrarily in the center of CIR2.

The complete set of statements for machining is listed below. Note that a cutter diameter of one (1) inch has been added. Figure 13 shows the center line path that will be calculated. The cutter statement creates the offset path shown by the dotted line.

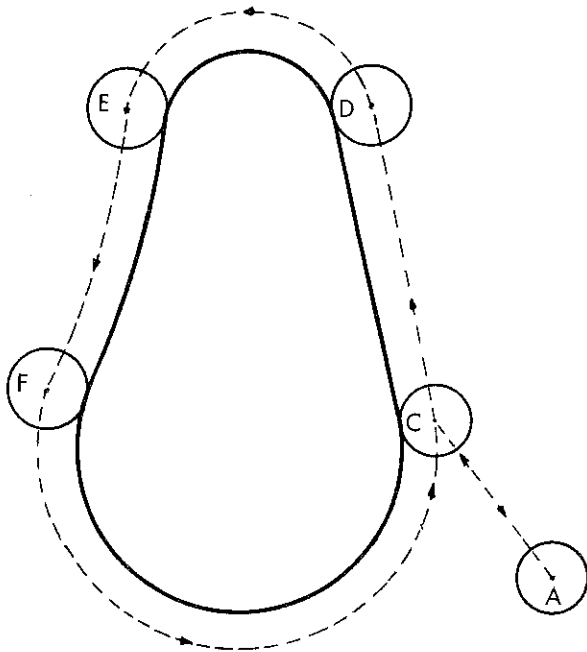

Computed Cutter Center Line Path

Figure 13

FEDRAT/8
 (Feed rate is 8 inches per minute)

CUTTER/1
 (Cutter diameter is 1.0 inches)

FROM/POINT/4,-1.6,0
 (Depart from a set point at X=4, Y=-1.6, Z=0, shown at Position A)

INDIRV/-1,1,0
 (In the direction of the unit vector)

GO/TO, LIN1
 (Go to No. 1 and Position C)

TLRGT,GOFWD/LIN1, TANTO, CIR1
 (With the tool on the right side of Line No. 1, go forward along Line No. 1 to the point of tangency with Circle No. 1 at Position D)

GOFWD/CIR1, TANTO, CIR3
 (Proceed forward around Circle No. 1 to the tangency point with Circle No. 3 at Position E)

GOFWD/CIR3, TANTO, CIR2
 (Proceed to the tangency point of Circles No. 3 and No. 2 at F)

GOFWD/CIR2, PAST, LIN1
 (Continue to Position C, the starting point)

GOTO/(POINT/4,-1.6,0)
 (Return to the starting point)

STOP
 (End of a sequence)

FINI
 (Note to computer that this is the end of this program)

Some additional statements for machining are required which turn on the spindle and coolant, select the required feed rate codes, determine the spindle speed codes, etc.; but the above statements will generate the center line points within specified tolerances. If an N/C drafting machine is to draw the part, a zero diameter cutter will create the exact outline drawing of the part as shown in Figure 13.

The foregoing illustration is abbreviated because most surfaces are three dimensional. Some of the other types of surfaces which can be programmed are:

1. Planes.
2. Spheres.
3. Ellipses.
4. Cones -- both circular and elliptical.

VEMCO'S MATCHED SET

for easier drafting instruction

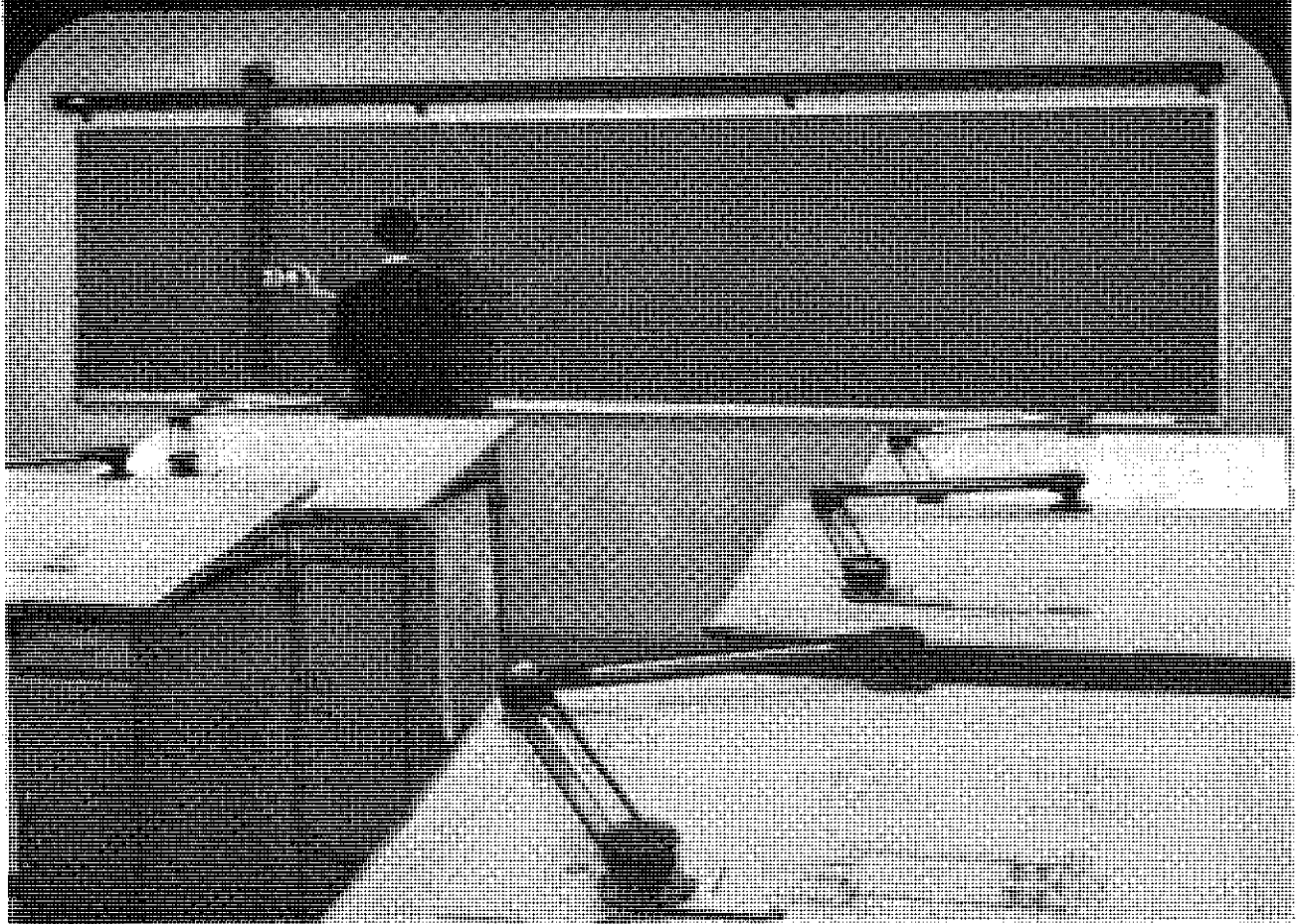

V-TRACK Drafting Machine with Chalkboard Adapter for the Instructor. At the tables, Model 3300 Drafting Machine, with either 16", 18" or 20" arms, special disc brake, and automatic 15° indexing, for students.



Add VEMCO American-made all steel Instruments, guaranteed without time limit ... compasses, dividers, ruling pens, scales... for a completely equipped classroom in drafting technique. Generous discounts on school orders.

Write for catalogs on V-Track;
Model 3300; Instruments.

V. & E. MANUFACTURING CO.
766 S. Fair Oaks Ave. / Pasadena, Calif.



5. Parabolas and paraboloids (circular and elliptical).
6. Hyperbolas and hyperboloids of one and two sheets.
7. Hyperbolic paraboloids.
8. Cylinders.

Any surface which is comprised of combinations of the above can readily be programmed on the APT system. Other capabilities of the APT system provide for translation and rotation of the part or sections of the part in the Cartesian coordinate system. The illustration in Figure 11 can be translated, rotated, or translated and rotated in the XY, XZ, or YZ planes by the computer if needed. APT has the capability for three-axis drilling operations too. Repetitive types of operations can be handled by MACRO, TRACUT, and COPY features. Four- and five-axis capability is being developed at this time to give APT the ability of handling programming for two- to five-axis operations inclusive.

The major limitation of APT in engineering education is that a large computer, such as the IBM 7094 or Univac 1107, is needed. Other computer programs for N/C are available such as ADAPT (ADAPTATION OF APT), AUTOPROMPT, and AUTOMAP which are IBM programs that utilize medium-size computers such as the IBM 1620. The capability of these programs, however, is limited to two-axis work.

One final remark about N/C computer-assisted programming. The information coming from the computer is insufficient to operate the equipment. Only the coordinate information has been calculated; and therefore, another program called a post processor is needed to add the preparatory functions, feed rate codes, miscellaneous functions, spindle speed codes, and convert absolute dimensional data to incremental mode, when needed, on the tape. Each machine has some unique characteristics and a post processor is normally required for each individual machine. Only when two machines in an installation are identical is it possible to use the same post processor; and it is an infrequent incident to have two identical N/C machines, particularly contouring, under one roof or in the same division of a manufacturing facility.

Engineering Education and Numerical Control

Engineering education will have an increased responsibility now that N/C has made its tremendous impact on manufacturing. Statements have been made to the effect that by 1970 all manufacturers, large or small, will have to be using N/C in order to keep pace with the competition. At least one engineering function, namely, process engineering, will be directly involved with N/C. From the previous examples given, it follows that research, product, design, and experimental engineering personnel will also be concerned with the application of N/C in their activities. Isolation between these engineering

activities will diminish, and each different engineering group will be more cognizant of the activities of the other groups.

Electronic maintenance training will have to be accomplished through Electrical Engineering. To date, most N/C education has come after the engineering student has graduated. In the near future, engineers will need training in N/C systems prior to graduation, which means that many colleges and universities will have to add pertinent courses to their curriculum. It is likely that much drafting time could be eliminated and freehand design sketches or computer-solved problems could be verified on a numerically controlled drafting machine, which would reduce much of the time restriction on design courses at the undergraduate level.

The training of personnel for manual and computer-assisted programming at the technician level, as well as engineering, appears just around the corner. To date, much of the programming training has been done by the manufacturers of N/C systems. With an evident increased need for programmers, courses in mathematics, machinability, processing, and computer programming will have to be handled by educational institutions on both regular and part-time programs.

Numerical control is a reality and here to stay. It is no longer looked at as an exotic, nice-to-have piece of equipment. Many companies have found that they can no longer go back to the "old" system of design, manufacturing, and research since they began applying N/C advantageously. Future applications and developments can only be conjecture; but it seems obvious that the utilization of N/C will be the approach that many, or perhaps all, manufacturers will need to take in order to prevent obsolescence in their manufacturing techniques.



FILE TO FILE from page 40

elements of descriptive Geometry in contrast to the approach used by your earlier correspondent.

Referring to the attached sketch, if a line of sight for a given orthographic view could be considered in the direction MP, that is, normal to the plane LMND, then the orthographic view of the original plane would become CDE. Pass a cutting plane CUV, parallel to LMP which cuts the line CF on CDE. Then, CF is also an orthographic projection (under the original premise) of a line CG that lies in plane ABC. CG is parallel to plane LMP.

Since ABC cuts plane LMP and since the line of intersection must lie in both planes then the line of intersection HT and BR can be constructed parallel to CG. CG also provides the direction for the intersection of ABC with the bottom plane. Since this line must be parallel to CG and pass through A, then AK fits the specification. By connecting C with both K and R (RC is parallel to AH) we have defined the basic intersection except for

the slot. This intersection can be easily defined by constructing a line IS through O parallel to FC. IS can be projected to plane ABC in the same manner as CF, to give line XY. The intersection of XY with line OQ defines the piercing point (Z) of line OQ and plane ABC. The intersection can be completed simply by connecting Z with B and T.

Although this is not the first solution submitted for this problem, I hope you find it of as much interest as I found it challenging and entertaining.



Dear Editor:

A most interesting solution of the "Can You Solve This" by Prof. M. Blade in the November issue of the "Journal" introduces as the first step in the solution a construction of a ratio of two line segments. This may be somewhat inaccurate especially when involved segments are of short lengths.

Attached please find a completely projective solution to the same problem. It is based on finding of the lines of intersection of plane ABC with the horizontal, frontal and profile planes of the object.

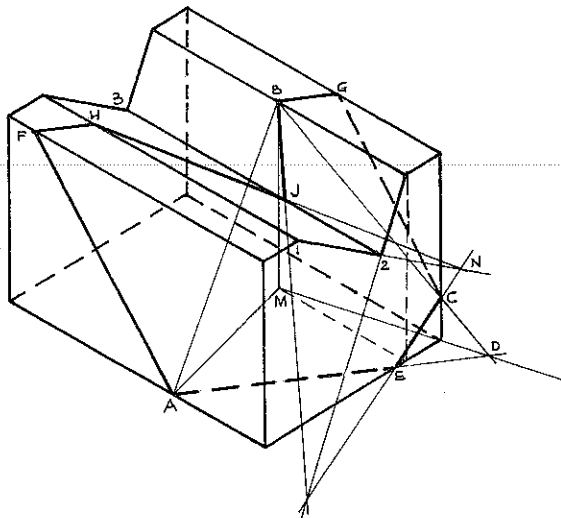

Solution:

1. Construct a vertical plane BMA and BMD.
2. Line AD is the line of intersection of plane ABC and the horizontal plane. (Base plane of the object.)
3. Line FBG // AED.
4. Line AF // CG.
5. Line 1, 2 ext. and EC ext. determine point N.
6. Line HN intersects 2, 3 at J.

Sincerely yours,

F. M. Hrachovsky, Assoc. Prof.
Department of Engineering Graphics
Illinois Institute of Technology

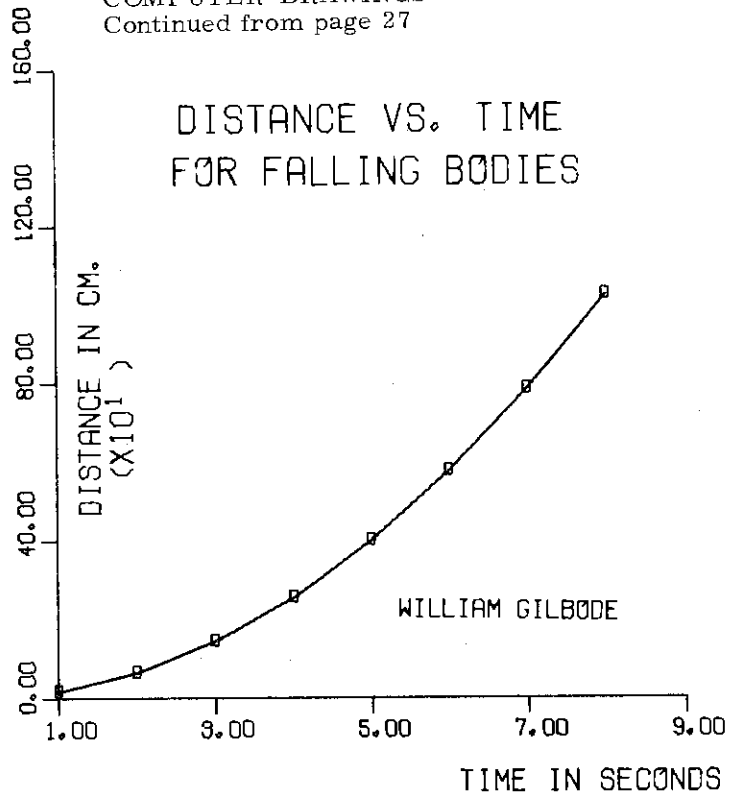

FIGURE 3

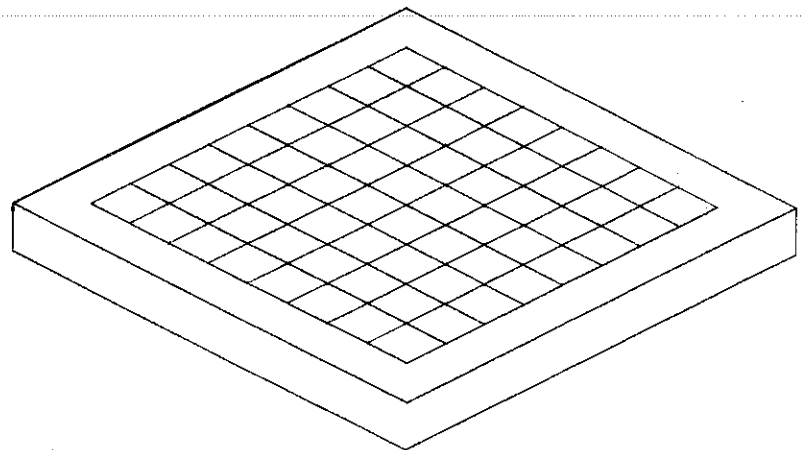

FIGURE 4

omitted lines. Figure 5 shows some computer-generated student-positioned arcs, almost touching, reinforcing the warning that the computer will draw the dictated rather than the desired curves and lines. Some examples of less successful first attempts are shown in Figures 7 to 10. A second try usually produces desired results.

References for interested students include the book "Computer Graphics in Communication" by Fetter, plus many articles in recent copies of "The Journal of Engineering Graphics" and "Graphic Science."

Continue on page 57

- 8. Give the student a reason for studying basic sciences and engineering sciences and an understanding of how these courses fit into the education of a professional engineer.
- 9. Place Engineering Graphics in its proper perspective in the modern engineering curriculum as a vehicle to support design.

NOTE: It is urged that each instructor of Engineering Graphics begin to experiment with the open-end design project method as a vehicle to teach the subject more effectively. As a starter, put aside one week of your present course and assign the following project:

SPILL PROOF FUNNEL

When filling the gas tank of an outboard motor, the power lawnmower, power saw, etc., through the use of a funnel, the tank often overflows onto the engine due to the difficulty in predicting the correct level of gas in the tank. This practice is extremely dangerous especially when the engine is hot. One remedy to this overspilling would be the use of a funnel that was designed to automatically close once the tank was 98 per cent filled.

ASSIGNMENT:

Design a spill proof funnel that will automatically close when the level of fluid reaches the full or almost full position. The partially filled funnel should serve as an indicator as to when the proper level is reached. A trip should be provided by passing the automatically closing valve so that the remaining gas in the funnel can be drained into the tank. This device, in a very inexpensive way, should prevent the spilling of any toxic or inflammable fluid.

Remind your students of the DESIGN PROCESS which includes the following:

GOAL OR NEED -- TASK SPECIFICATIONS -- CONCEPTION -- ANALYSIS -- SOLUTION

Require that they write a list of Task Specifications before beginning to design, conceptual sketches to be performed free-hand on coordinate paper. The solution as presented is to be a working drawing. The instructor is then in a position to sit back and wait for the results. You should be greatly rewarded for your efforts.



"Are you using GRAPHICS to sell GRAPHICS?"

Figure 2 indicates the graphical construction required for the graphical determination of the product combinations of the powers of the sine and cosine; i.e., along the sine axis (s), $0 - 1$ is the sine of θ and $0 - 2$ is the square of the sine of θ times the cosine of θ , while along the cosine axis (c), $0 - 1$ is the sine of θ times the cosine of θ and $0 - 2$ is the square of the cosine of θ times the sine of θ . It is obvious that the construction can be extended for any product combinations of the powers of the sine and cosine of θ and the value determined by measurement with a scale.



THE RESULT OF COMPLETE DIMENSIONAL REFORM

Alpheus C. Bemis
Assistant Professor of Mechanical Engineering
Product Engineering Department
General Motors Institute

From time to time there is a rejuvenation of the move to replace our confusing "English" system of measurement and its rods, gallons, feet, bushels, etc. The advocates of the metric system claim that their chosen system is much more logical and simpler. They even discount the decimal inch standard by claiming advantages in this area even though the metric system thus far requires a "rounding off" of numerical values which reduces the practicality of mass production as we witness it in the United States and Canada today.

It behooves one at this time, however, to consider the impact on our everyday lives and conversation should we completely convert our thinking to the metric system. For example our Texas friends would wear 37.853 liter (ten gallon) hats and 33.81 kilometer (7 league) boots. If we wanted to talk of love and say "we love you a bushel and a peck and a hug around the neck," instead we would have to say "we love you 35.24 liters and 8.81 liters, etc." We would also have to put our best .305 meter forward and not our "best foot." Some of us would walk 1.6093 kilometers for a Camel cigarette, while others, believing that 28.35 grams of prevention are worth 453.59 grams of cure. We could no longer walk a mile for the Camel nor use the cliché, "an ounce of prevention is worth a pound of cure." We would have to use the expression "wouldn't touch one with a 3.048 meter pole" in place of "a ten-foot pole." And the title of the book "God's Little Acre" would become "God's Little .4047 of a Hectare."

We must watch these dimension reformists. Give them 2.54 centimeters and they will take 1,609.34 meters (give them an inch and they'll take a mile) every time.



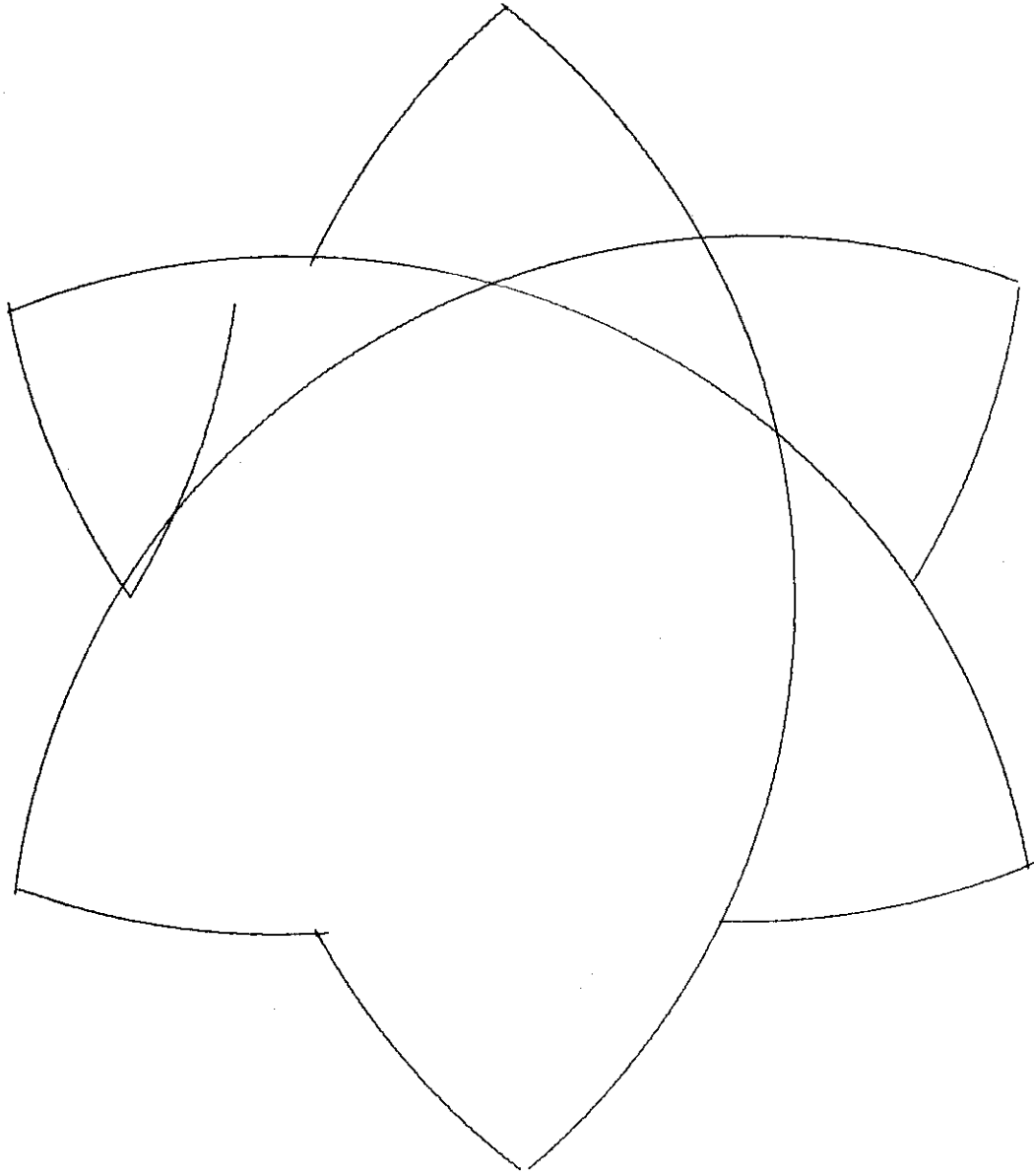

FIGURE 5

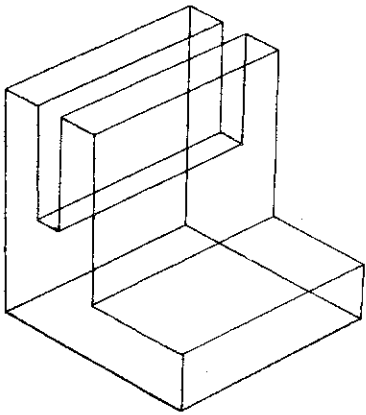

FIGURE 6

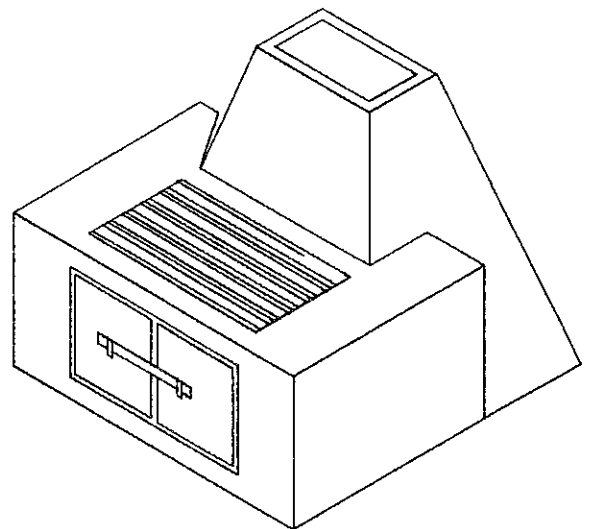

FIGURE 7

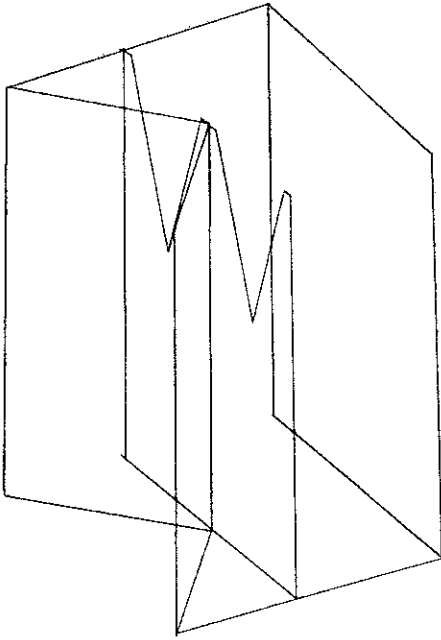

FIGURE 8

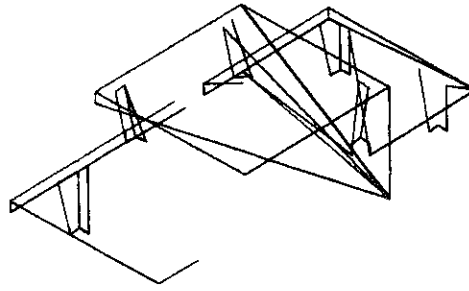

FIGURE 10

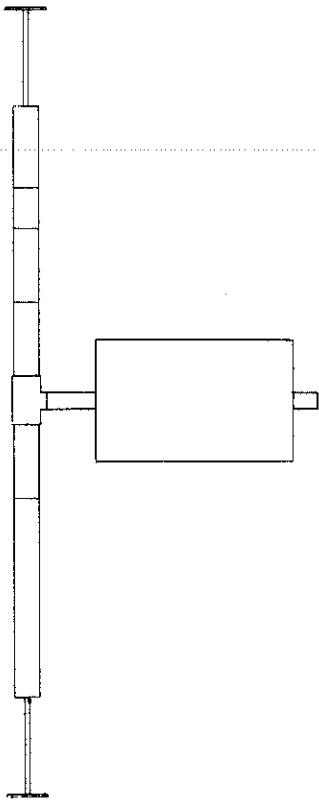

FIGURE 9

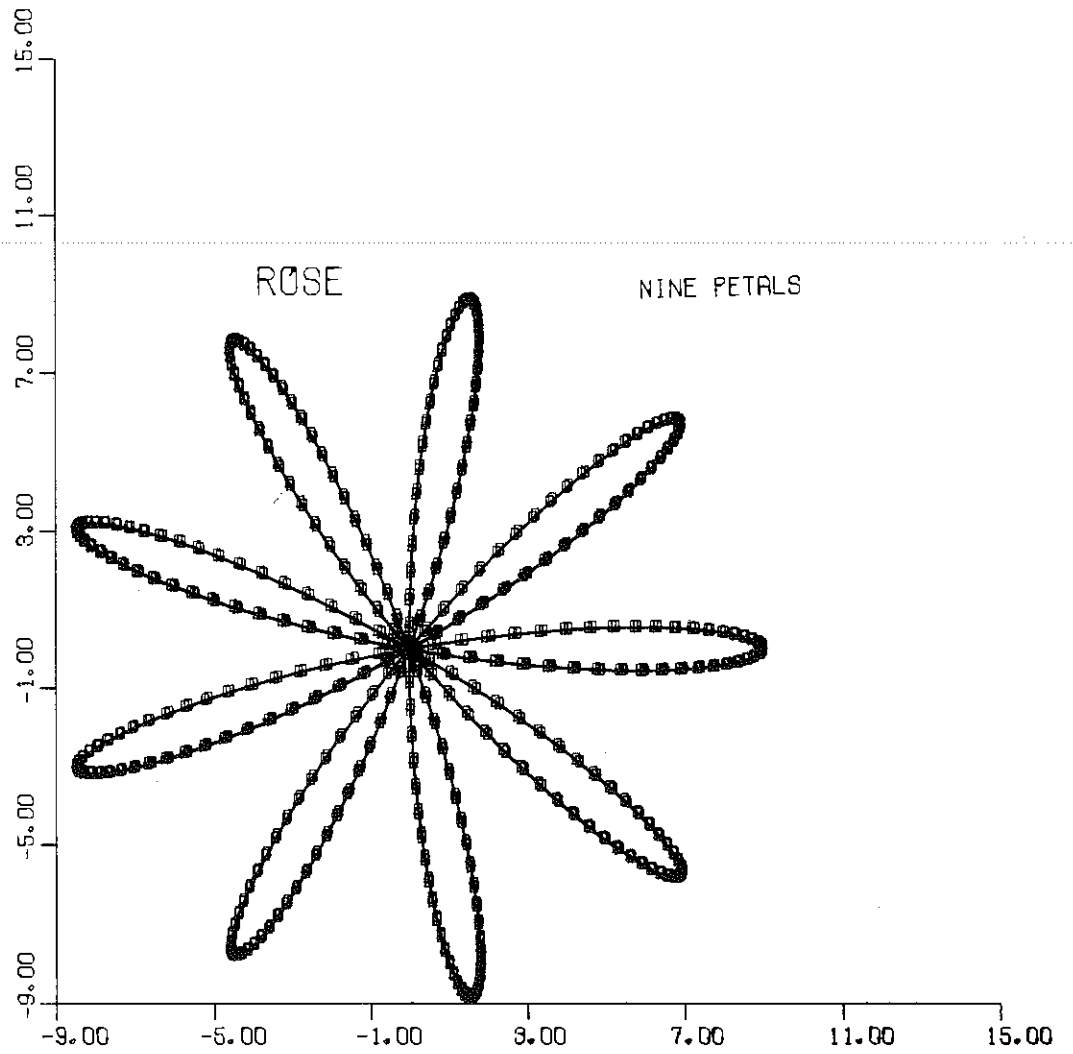

FIGURE 11

school courses are ineffective. The use of engineering graphics as a tool of analysis, of creative thought, and as a pictorial language should be encouraged. An increased importance should be given to the general area of creative design experience rather than routine experiences that stress details at the expense of comprehensive understanding. All engineering courses should include the development of a high level of performance in the oral, written, and graphical communication of ideas.

An engineer must look beyond the strictly technical aspects of his profession and include his social obligation to society. Teachers of social studies in engineering should not dominate the students with their own ideas but should present facts objectively. They should draw students into evaluating all situations and ideas critically.

E. D. B.



PROPOSED CHANGE IN DIVISIONAL BY-LAWS ARTICLE VI - SECTION 4

The Publication and Editorial Board of the JOURNAL OF ENGINEERING GRAPHICS

Section 4. The Publication and Editorial Board
of the Journal of Engineering Graphics

- a. The Publication Board consists of the Journal Editor, Advertising Manager, and Circulation Manager and Treasurer. They shall act as the administration officers of the JOURNAL including the fixing of advertising rates, size of Journal and financing. Changes in subscription rates, as recommended by the Publication Board, must be approved by the Executive Committee of the Division at the annual meeting before becoming effective.
- b. Term of office. These officers shall be elected for a term of three years, each to be elected in the off years of the other two.
- c. Duties of these officers.

(1) Editor. The chief administrative officer. He is responsible for the editorial policy of the JOURNAL, solicitation and selection of material to be published, physical makeup of each issue, signing contracts with printers and publishers, and timely delivery of the completed Journal to the circulation manager for distribution. He is also responsible for maintaining an accurate

accounting of all expenses contracted in preparing copy for publication and promptly reporting same to the Journal treasurer. The editor or editor elect shall annually nominate two candidates for the Editorial Board to serve as Assistant Editors. These nominations are submitted to the Divisional Executive Committee for approval at the annual meeting of the Division. He shall act as chairman of both the Publication and Editorial Boards. He shall serve as a member of the Divisional Executive Committee. His duties also include semiannual written reports to the Divisional Executive Committee and general business meetings of the Division.

(2) Advertising Manager. The advertising manager is responsible for all advertising in the JOURNAL. He writes advertising contracts, mails invoices to advertisers, and collects advertising payments. He solicits new advertisers and shall deliver all advertising copy to the Editor ready for camera. He maintains accurate records of all advertising contracts, and promptly forwards all payments to the Journal treasurer for deposit. He maintains liaison with advertising agencies and answers complaints from advertisers or their agents. He shall serve as a member of the Divisional Executive Committee. He submits a semiannual written report at the annual and mid-year Divisional business meetings.

(3) Circulation Manager - Treasurer. This officer is responsible for distributing the JOURNAL to subscribers and contributing writers as directed by the EDITOR (usually two copies per contributor). He maintains an accurate record of current subscribers, promptly distributes each issue of the JOURNAL, notifies each subscriber of subscription expiration, and solicits new subscribers. He maintains a liaison with magazine subscription agencies listing the JOURNAL, answers correspondence from subscribers or their agents, and fills orders for single copies.

The Journal treasurer is responsible for all Journal funds and shall pay all costs connected with the publication of the JOURNAL. He is responsible for keeping an accurate record of accounts in standard book-keeping form, have these accounts audited once each year, and present this audit at the Annual Meeting of the Division. He shall be a member

of the Divisional Executive Committee. He also is to keep the Editor of the JOURNAL and the Chairman of the DIVISION informed as to the balance on hand, accounts receivable, and outstanding accounts payable. At the end of his term of office, he shall transmit to his successor all financial and circulation records, together with all monies in the Journal account.

- (4) If the Publication Board desires, a member of the Division from each institution may be designated to solicit subscriptions, collect subscription fees, and transmit them with complete mailing addresses to the Circulation Manager-Treasurer.
- d. The Editorial Board consists of the Editor, Editor Elect, two Assistant Editors, and other editorial officers which may be appointed by the Editor.

(1) Editorial Assistants. There shall be at least two Assistant Editors nominated annually by the Editor and approved by the Divisional Executive Committee. They shall be members of ASEE in good standing. Their duties are to assist the Editor in reading and advise him in choosing material to be published, assist in the physical preparation of publication copy, serving as required as art editors, proof readers, and other duties as assigned by the Editor.

(2) The Editorial Board shall work in close cooperation with the Division Editor, recognizing that ASEE has a prior claim on any papers presented at the annual and mid-year meetings of the Division.



The engineer's designs must be accurate and functional, otherwise his work may become fatal to his career as well as the safety of others.



It is easy enough to get attention -- the problem is to get results.



"They can "SEE" graphics."



The engineer must either anticipate change or become a victim to it.

ON DRAWING EXHIBITS

An informal display of student work is encouraged by the Engineering Graphics Division's Display Committee for the annual meeting in June, 1966 at Washington State University.

The location of the display will not be in the meeting program but will be announced at the Monday morning session of the Engineering Graphics Division. The display will be located in one of the Engineering Graphics classrooms.

Mail or deliver your exhibit material to:

Professor Jack T. Kimbrell
EG Materials
Department of Mechanical Engineering
Washington State University
Pullman, Washington 99163

Jack cannot ensure the return of exhibit material unless you make special arrangements with him. Neither Jack nor WSU will accept responsibility for loss, damage, or theft.



CALENDAR OF ASEE AND DIVISION OF ENGINEERING GRAPHICS

June 20-24, 1966	Annual Meeting - Washington State University, Pullman, Washington
1966-67	Midyear Meeting - Northeastern University, Boston, Massachusetts
June 19-23, 1967	Annual Meeting - Michigan State University, East Lansing, Michigan
1967-68	Midyear Meeting - University of South Florida, Tampa
June 17-21, 1968	Annual Meeting - University of California at Los Angeles, California
1968-69	Midyear Meeting - Louisiana State University, Baton Rouge
June , 1969	Annual Meeting - The Pennsylvania State University, University Park, Pa.
1969-70	Midyear Meeting - California State Polytechnic College, San Luis Obispo
June , 1970	Annual Meeting - The Ohio State University, Columbus, Ohio



INFORMATION FOR AUTHORS

Manuscripts. Articles or papers may be descriptive, theoretical, documentary, tutorial in nature, or they may be reviews. Editorial considerations suggest most papers should be 2000 to 4500 words in length. The topic should receive professional treatment in depth. One or two copies of the manuscript should be submitted. Articles should be typewritten and double spaced with typing only on one side of each sheet. Pages should be numbered to avoid omissions. References, footnotes and illustrations should be listed on separate sheets and not inserted within the text.

Illustrations. Line drawings may be prepared in pencil or India ink with mechanical lettering. If mechanical lettering is not available, freehand lettering should be placed on a separate overlay sheet. Photocopies (same size or reduced) of the original line drawings are accepted if they are clean, clear and sharp in contrast. Illustration width limitations are (1) single column, 4-1/8 inch, and (2) double column, 9 inches. Height limitation is 11-3/4 inches for either column width. When illustrations are reduced 20%, all lettering must be large enough to remain clear and legible. Photographs should be 8 x 10 glossy prints. Figure numbers and captions should be listed on a separate sheet. If there could be any doubt about the positioning of the illustration, identify its top with a blue pencilled note in the margin. Figure numbers should be lightly written on the back of each illustration. If the illustration is prepared on translucent material, a blue pencilled note might be made in the lower margin on the face of the illustration.

Correspondence. Your candid observations via brief communications are welcomed. Your observations; criticism of, or comments on, previously published articles; or other timely notices of interest to the members of the Engineering Graphics Division are welcomed. Please indicate whether submitted correspondence may be published.

Writing Style. Spelling and capitalization should follow Webster's Seventh New Collegiate Dictionary, which also offers guidance in punctuation. For more detailed information of the editorial style, see United States Government Printing Office Style Manual, 1959.

If you have further questions -- write to the Editor.

Earl D. Black, Editor
The Journal of Engineering Graphics
General Motors Institute
Flint, Michigan 48502

Continued from page 8

NEW YORK STATE HAS INTRODUCED ENGINEERING GRAPHICS IN COLLEGE PROFICIENCY EXAMINATION PROGRAM

William A. Lyons, Director of the College Proficiency Examination Program, The University of the State of New York informs us that there are two college proficiency examinations in engineering graphics now available to students who wish to try for advanced credit. These examinations are designed to test the candidate's competency and ability to understand engineering drawings, and his ability to prepare drawings from written or verbal specifications and from sketches. They are also intended to test his ability to visualize space concepts as they apply to engineering and science problems.

Graphics A test covers drawing for design and examines the student in four basic content areas: Theories of projection; drawing for production; freehand lettering and sketching, conventions; and geometric constructions; and graphs, charts, diagrams, and special purpose drawings. Recommended credits: 4 to 6.

Grade B test covers drawing for analysis and synthesis. The knowledge of principles and a problem-solving ability in descriptive geometry and graphical mathematics for engineering and science spatial concepts is included.

In this examination the student is checked in six basic content areas: Theories of projection systems; drawings for production-basic dimensioning for function, interchangeability, and manufacturing ability; lettering and sketching; graphs, charts, diagrams and elementary knowledge of special purpose drawings; fundamentals of descriptive geometry and special applications; and graphical mathematics, functional scales, solutions of equations, nomography and alignment charts. Recommended credits: 3 to 4.

The college proficiency examination committee in engineering graphics is:

Mary Blade, Cooper Union, Chairman
Carson Buck, Syracuse University
James Forman, State University
Agriculture and Technical College
at Alfred
Harold Howe, Rensselaer Polytechnic
Institute
Yonny Segel, Bronx Community College

The Journal of Engineering Graphics

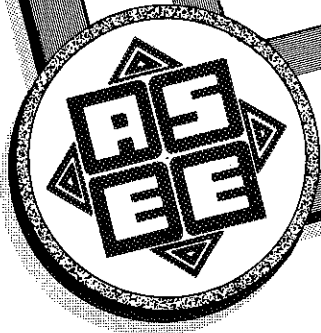

Lay your triangle along here, tear off and mail to:

James H. Earle, Engineering Graphics Department
Texas A & M University, College Station Texas

Please enter my subscription to the Journal of
Engineering Graphics. 1 yr. \$2. 2 yrs. \$4.

Enclose check or money order

Name _____
Address _____
City _____

State _____ Zip _____

THREE-PRONG U-BAR APPLIED TO FOOD CHOPPERS

By

William F. Carpenter, Chairman
Mathematics Department
and

H. W. Blakeslee, Instructor
Technical Education Department
of
Central Florida Junior College
Ocala, Florida

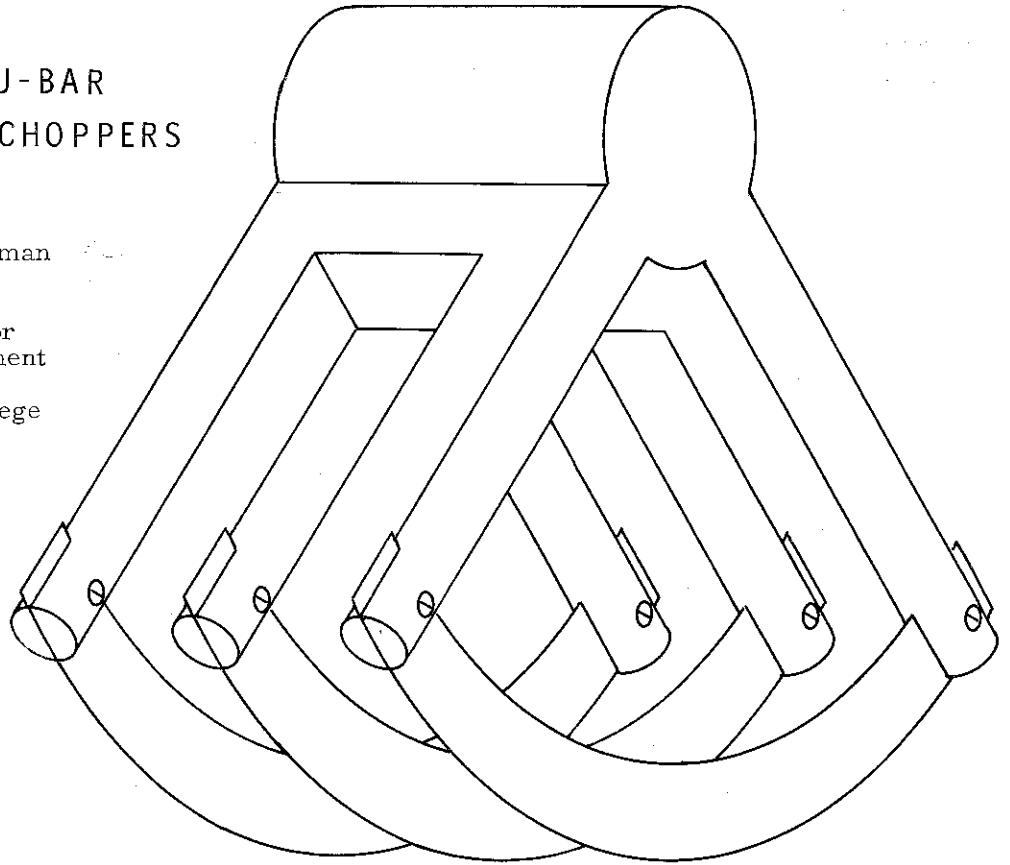

FOOD CHOPPER FOR SMALL BOWLS

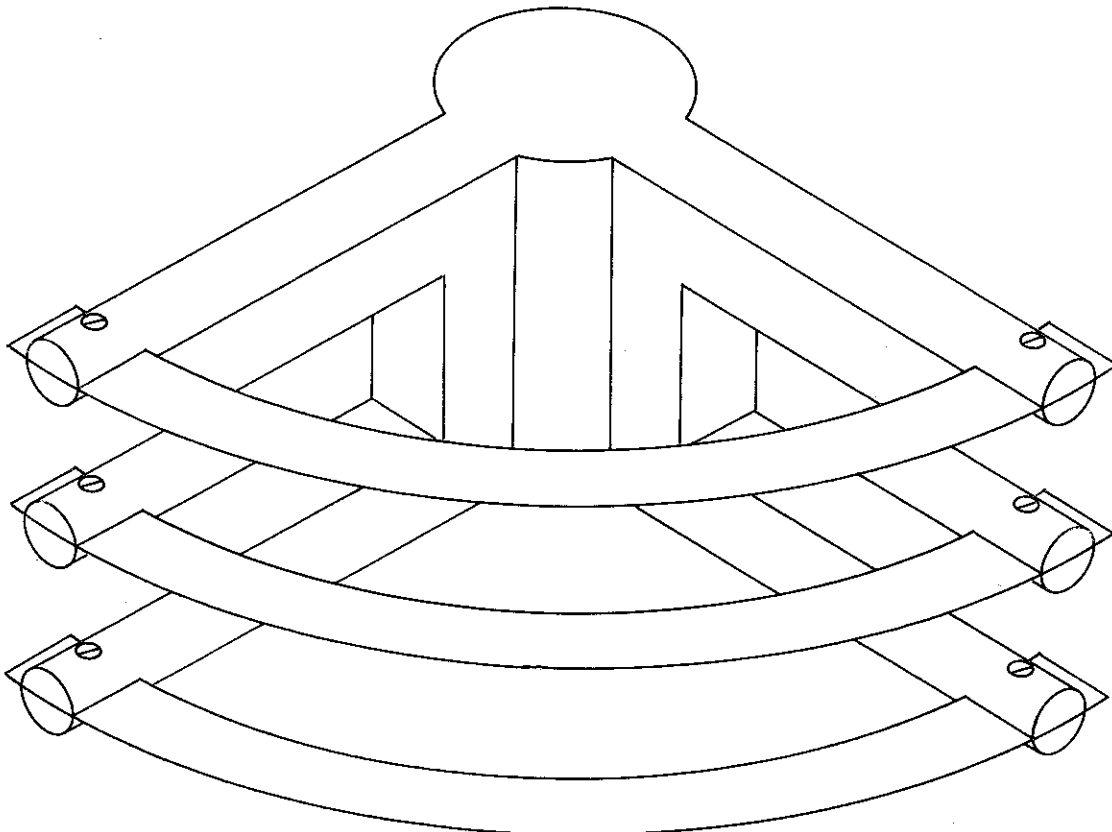

3 BLADE FOOD CHOPPER (WIDE ANGLE, FOR LARGE BOWLS)

designed with
YOU in mind!

This is the T-square every one will want because it is the most convenient to carry, to store, to draw . . . recessed hardwood blade prevents blotting and slippage. The patented detachable head locking device assures perfect alignment when assembled. The waterproof zippered sheath makes this T-square the most convenient to carry — in the world! Just wait 'till you see it!
18", 24", 30", 36" and 42"

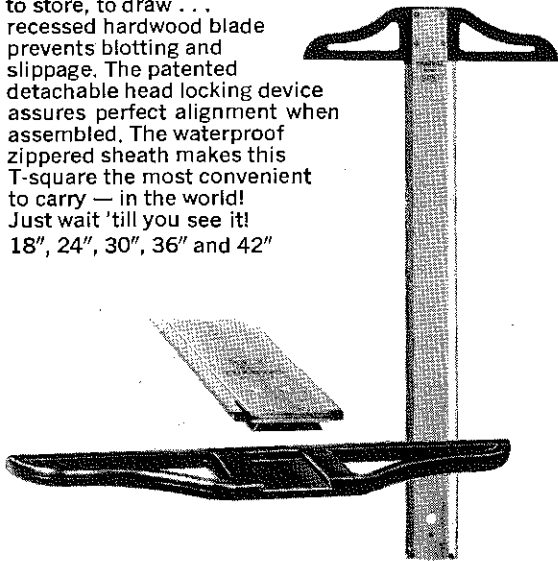

charvoz
SAFE-T-LOCK
T SQUARES

. . . the most convenient to carry
— in the world!



charvoz-carsen corporation

50 COLFAX AVENUE, CLIFTON, NEW JERSEY 07013

In Canada: 31 Scarsdale Road, Don Mills, Ontario

Template Designs for
Every Trade & Profession

Modern, Timesaving Drawing,
Designing and Sketching Aids for
Unlimited Applications —



YOUR TEMPLATE SUPPLY HOUSE

A Complete Stock Of
ARCHITECTURAL • MECHANICAL • ELECTRONIC
STRUCTURAL • MATHEMATICAL • ELECTRICAL
LETTERING • ELLIPSES • SCIENTIFIC
PLOTTING • PROCESSING • GENERAL SYMBOLS
CIRCLES • CHEMICAL • MISC. SPECIALIZED
Templates

Custom Templates Made To Order

ALVIN & COMPANY, INC.
Importers, Manufacturers, Distributors
WINDSOR, CONNECTICUT
Area Code 203-6884931

"for Quality At The Right Price"

