

# JOURNAL OF ENGINEERING DRAWING

VOL. 13, NO. 2

MAY, 1949

SERIES NO. 38

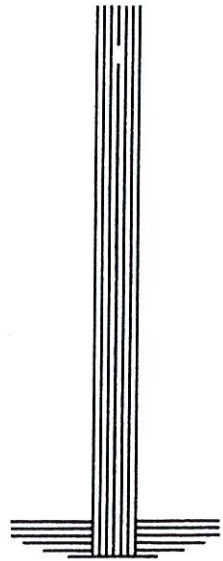
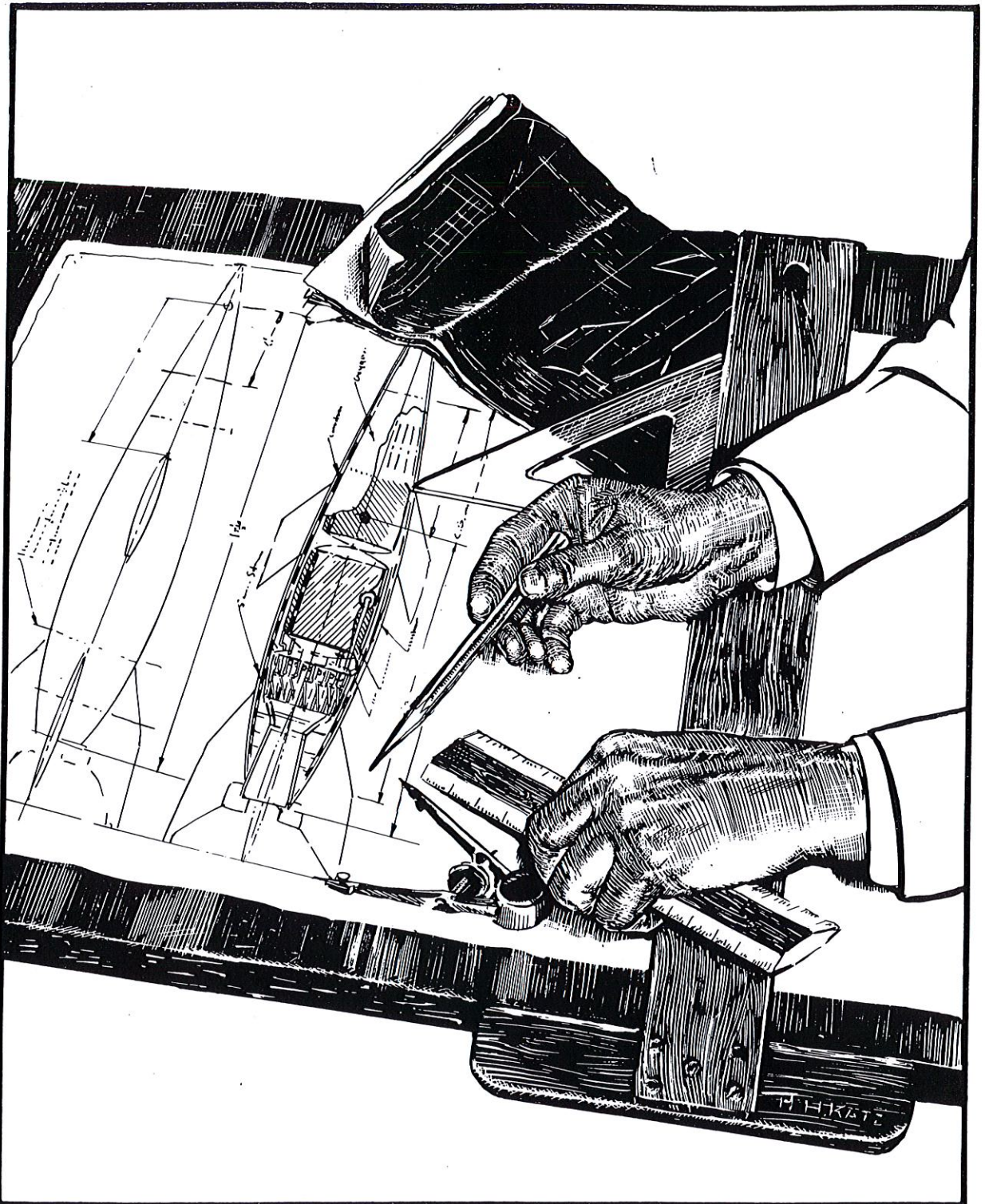

PUBLISHED  
BY  
THE  
DIVISION  
OF  
ENGINEERING  
DRAWING  
AND  
DESCRIPTIVE  
GEOMETRY  
A S E E

Ready

for fall classes

# TECHNICAL DRAWING

by  
Giesecke, Mitchell  
and Spencer

NEW  
*Third Edition*

*Fig. 931. Reduced from its actual size in the book, this illustration of a cut-away assembly pictorial is typical of the new illustrations in the third edition of G.-M.-S.*

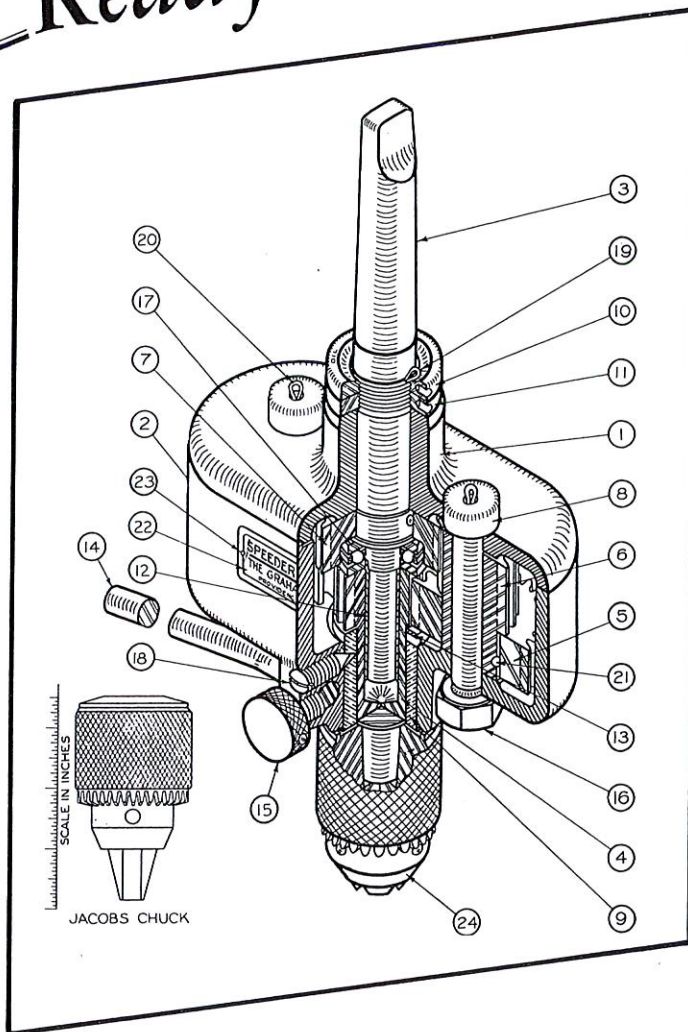

## *Revised . . . Rewritten . . . New Problems . . . New Illustrations*

The earlier editions of this text have been widely acclaimed as a general class text, reference book, and home study book on technical drawing. You will find in the new third edition, which conscientiously incorporates many of the suggestions, big and little, offered by teachers all over the country, a new polish and a higher degree of accuracy in regard to details than ever before. *To be published this summer. \$4.50 (probable).*

**Revised . . .** The entire book has been gone over to bring it into exact agreement with the new American Standard Drawing and Drafting Room Practice (ASA Z14.1-1946). In addition this standard is reproduced in its entirety in the Appendix.

**Rewritten . . .** Approximately 25% of the text matter has been completely rewritten. Fuller, simplified, and more detailed explanations have been added in every chapter.

**New Illustrations . . .** The new edition contains about 100 new drawings and about 100 of the present illustrations have been redrawn and enlarged, thus doing away with "eye-killers."

**New Problems . . .** All problem layouts have been changed to agree with the American Standard size of 11" x 17" or 8½" x 11". There are many new and better problems throughout with 50% more Auxiliary view problems and almost twice as many new sectioning problems with emphasis on the more advanced type of problem.

**New Material . . .** Many new articles have been added on Dimensioning, almost trebling this section. A completely new article on "Axonometric Projection by the Method of Intersections" has been added on the relatively new development in the field, presenting it from a new and simplified approach which makes trimetric drawing about as easy as isometric drawing. A wealth of information has been added in a new section on Shop Processes.

**JOURNAL OF ENGINEERING DRAWING**  
 PUBLISHED IN THE INTEREST OF TEACHERS OF ENGINEERING DRAWING  
 AND RELATED SUBJECTS

VOL. 13, NO. 2

MAY, 1949

SERIES NO. 38

**CONTENTS**

|   |         |
|---|---------|
| COVER PAGE: by H. H. Katz, Director, Allied School of Mechanical Trades; Chicago, Illinois. . . . .   | Page 1  |
| RENSSELAER POLYTECHNIC INSTITUTE. . . . .   | Page 5  |
| NEW YORK, HERE WE COME! by H. C. Spencer, Chairman Division of Engineering Drawing of the ASEE, , . . . . .   | Page 5  |
| WELCOME TO RPI, by Richard W. Schmelzer, Rensselaer Polytechnic Institute. . . . .  | Page 5  |
| STUDENT WORK AND COURSE OUTLINE DISPLAY by Professor James R. Rising, Chairman, Display Committee. . . . .  | Page 6  |
| PROGRAM, Division of Engineering Drawing, ASEE--Annual Meeting. . . . .   | Page 7  |
| ON WHAT BASIS SHOULD ENGINEERING COLLEGES GRANT CREDIT FOR HIGH SCHOOL DRAWING? by Prof. R. R. Worsencroft, University of Wisconsin. . . . .  | Page 8  |
| MILITARY GRAPHICS - Instruction in Engineering Drawing and Military Topography at West Point, by Col. L. E. Schick, Head of Dept. M. T. & G., U. S. Military Academy, West Point, N.Y.. . . . . | Page 11 |
| LOGIC OF VISUALIZATION by B. L. Wellman, Worcester Polytechnic Institute, . . . . .   | Page 15 |
| REPORT OF MID-YEAR MEETING by O. W. Potter, Secretary of Engineering Drawing Division- ASEE . . . . .   | Page 20 |
| NEWS ITEMS. . . . .   | Page 21 |
| BIBLIOGRAPHY REPORT by Professor H. H. Fenwick, University of Louisville . . . . .  | Page 32 |

Annual Subscription Price, \$1.00

PUBLISHED IN FEBRUARY, MAY, AND NOVEMBER BY  
 THE DIVISION OF ENGINEERING DRAWING AND DESCRIPTIVE GEOMETRY OF THE  
 AMERICAN SOCIETY FOR ENGINEERING EDUCATION

PUBLICATION COMMITTEE

T. T. Aakhus, Editor  
 University of Nebraska  
 LINCOLN, NEBRASKA

Charles J. Vierck, Advertising  
 The Ohio State University  
 COLUMBUS, OHIO

Ralph T. Northrup, Cir. & Treas.  
 Wayne University  
 DETROIT, MICH.



Troy Building, Rensselaer Polytechnic Institute  
Department of Civil Engineering and Department of Mechanics

## NEW YORK, HERE WE COME!

by

Henry Cecil Spencer  
Chairman, Division of Engineering Drawing of the ASEE

All teachers of engineering drawing are cordially invited to attend the next annual meeting of the ASEE at Rensselaer Polytechnic Institute, Troy, New York, June 20-24, 1949. The Executive Committee of our division has prepared a fine program, and it is expected that this meeting will be one of the best we will have ever had.

The American Standards Association Z14 Committee has been reactivated, with Dean Randolph P. Hoelscher as Vice-Chairman, and preliminary work is going forward in the revision of the present "American Standard Drawings and Drafting Room Practice". The SAE is also very active in the preparation of its drafting standards at this time. We shall hear of the latest developments in these fields and also about foreign drafting practices.

Another feature of this meeting will be the Display of Student Work and of Historical Items which is being prepared under the chairmanship of Professor James S. Rising. All departments should start at once to assemble the materials they expect to display

in June. It is hoped that we will have the most complete display of its kind ever assembled to date.

The State of New York has been called a Summer Playground, and a very informative article on the possibilities of combining a summer vacation with the ASEE meeting was published in the January issue of the Journal of Engineering Education. Troy is located on the east bank of the Hudson River in the central extreme eastern part of the state. Across the river is the Watervleit Arsenal which we expect to visit on our inspection trip. After the meeting, you may drive down the Hudson 150 miles to New York City to see the Rockettes, among other things.

On the way, you may stop over for a look at the U. S. Military Academy at West Point; or you may head north and take in Quebec, Montreal, Ottawa, and other points of interest in Canada. Clearly, the trip to Rensselaer can be one of the most profitable, and enjoyable of your life. Why not make your plans now to be there?

## WELCOME TO RPI

by

Richard W. Schmelzer  
Rensselaer Polytechnic Institute

Rensselaer welcomes you to the 57th Annual Meeting of the American Society for Engineering Education. An interesting and varied program is being prepared for the members of the Engineering Drawing Division who are planning to attend the meetings at Troy, N.Y.

In addition to the regular conferences, luncheon, and dinner of the Division, trips are being planned to industrial plants in the Albany-Schenectady-Troy area and to Lake George and the Adirondacks. If this latter trip or trips do not produce enthusiastic boosters for New York's northern vacationland, it will not be the fault of Professor Harold B. Howe, head of RPI's Engineering Drawing Department, who is making the local arrangements for the activities of the Division.

A program for the ladies attending the meeting includes a trip to the General Electric House of Magic in Schenectady, a tri-state tour with visits to Williamstown, Massachusetts, and Bennington, Vermont, through some of the finest scenery in New England, and a visit to places of historic interest in Albany and vicinity.

Delegates and their families will be housed for the most part in dormitories on the campus and in the dormitories of Russell Sage College in downtown Troy. Meals will be served in the Institute's dining hall and cafeteria.

If a boat is available, a moonlight trip on the Hudson replete with a buffet supper on the boat and band music will

feature the Tuesday evening entertainment. Unfortunately the Hudson River Day Line is now in the process of changing ownership; consequently no definite commitment for such an excursion can be made at this time.

The countryside around Troy is beautiful in June and those who come by automobile to

the meeting will have the opportunity of taking many rewarding short trips.

A large local hospitality committee is getting together each week in order to try and anticipate the needs and wishes of the visitors, and everyone traveling to Troy this June can be assured of a most cordial reception.

## STUDENT WORK AND COURSE OUTLINE DISPLAY HISTORICAL DISPLAY

at the Annual Meeting, June 20 - 24, 1949  
RENSSELAER POLYTECHNIC INSTITUTE, TROY, NEW YORK

At the Mid-Winter Meeting of the Drawing Division held at The Ohio State University, Columbus, Ohio, a Committee was appointed to plan and conduct at the Annual Meeting a "Display of Student Work and of Historical Items".

To make this display a success, your Committee is asking the cooperation of each institution in sending or bringing an exhibit for the June Meeting. It is not intended that the display be one largely of technique, but rather one of which an inspection will give basis for comparison of time, coverage, and credit at the various schools. With this in mind the Committee requests that the exhibits be prepared as follows:

### 1. STUDENT WORK

- (a) Bring or send firmly bound folders of recent student work for each course offered in Drawing and Descriptive Geometry.
- (b) Accompany each folder by a 3 x 5 card on which is typed the following information:

SCHOOL: \_\_\_\_\_  
 NAME OF COURSE: \_\_\_\_\_  
 NO. OF WEEKS: \_\_\_\_\_  
 CLOCK HRS. PER WEEK: \_\_\_\_\_  
 HOURS LECTURE: \_\_\_\_\_  
 HOURS LABORATORY: \_\_\_\_\_  
 HOURS HOME PREPARATION: \_\_\_\_\_  
 CREDIT HOURS: \_\_\_\_\_  
 TERM GIVEN: \_\_\_\_\_  
 PREREQUISITES: \_\_\_\_\_  
 TEXT BOOK: \_\_\_\_\_

- (c) The folder of student work may well be prefaced with assignment sheets, instruction sheets, quizzes and examination sheets in their sequence of presentation so as to give the person viewing them a comprehensive outline of the course.

- (d) Send or bring to:

Professor Harold C. Kinner  
 Carnegie Building  
 Rensselaer Polytechnic Institute  
 Troy, New York

to arrive before noon on June 20, 1949.

- (e) At the end of the meeting, the material should be picked up by the school representatives or will be returned by express collect to the schools who have not taken up their display.

### 2. HISTORICAL DISPLAY

The following items will hold great interest for members of the Division if they are brought or sent to Professor Kinner at R.P.I. as indicated previously.

- (a) Text Books of historical interest on Descriptive Geometry, Engineering Drawing (Old and Rare copies - First Editions) and related subjects.
- (b) Drawing instruments and tools.
- (c) Rare and Old Drawings.
- (d) Drawings by students who later become world famous.
- (e) Drawings from Foreign Countries.
- (f) Photographs of historical interest related to the drawing field or people in the field.
- (g) Any items which show the evolution of drawing teaching and technique.

Any special instructions concerning care and return of historical items should be included when sending to Professor Kinner.

Your exhibit for this feature of the June Meeting is earnestly solicited.

PROGRAM

Annual Meeting--Engineering Drawing Division of ASEE  
Rensselaer Polytechnic Institute  
 Troy, New York, June 20-24, 1949

H. C. Spencer, Chairman, Illinois Institute of Technology

O. W. Potter, Secretary, University of Minnesota

Harold B. Howe, Local Chairman

Monday, June 20, 1949

9:00 A.M. - ASEE Registration.

2:00 to 5:00 P.M. - Conference.

Ellipse Guides. - J. G. McGuire, Texas A & M College.

Foreign Drafting Practices. - T. C. Brown, North Carolina State College.

S. A. E. Drafting Standards. - Mr. J. H. Hunt, General Motors Corp.

Z14 Progress Report. - R. P. Hoelscher.

Discussion.

Display of Student Work and of Historical Items. Each school is asked to send in bound folders or booklets representing the work done in its courses.

Display Committee:

James S. Rising, Chairman

Harold G. Kinner

William Street

6:00 P.M. - Dinner, Executive Committee Business Meeting.

Tuesday, June 21, 1949

10:00 A.M. - ASEE General Session.

12:30 P.M. - Luncheon.

Committee Reports and other Business:

Nominating Committee (Election Results) O. W. Potter, Chairman

Constitution and By-Laws Committee. Justus Rising, Chairman

Advanced Graphics. Frank Heacock, Chairman

Tests. Ralph Paffenbarger, Chairman

Journal of Engineering Drawing. Ralph Northrup

T-Square Page. Warren Luzadder

St. Louis Summer School Proceedings. R. P. Hoelscher

Round Table Discussion of Engineering Drawing Division Objectives.

Led by F. G. Higbee.

8:00 P.M. - ASEE General Entertainment.

Wednesday, June 22, 1949

10:00 A.M. - ASEE General Session.

2:00 to 4:00 P.M. - Conference.

Visualization. Mary Blade. The Cooper Union.

Welding Symbols. Speaker from the American Welding Society.

Logic of Multiview Approach in Descriptive Geometry.

B. Leighton Wellman, Worcester Polytechnic Institute.

Discussion.

6:00 P.M. - Dinner. - Speaker: Dr. Charles H. Gray, Head of English Department, Rensselaer Polytechnic Institute.

Invitations from possible host institutions for next Mid-Winter Meeting.

8:00 P.M. - Meeting of New Executive Committee, presided over by new chairman.

Thursday, June 23, 1949

10:00 A.M. - ASEE General Session.

2:00 P.M. - Inspection Trip through Watervleit Arsenal.

## ON WHAT BASIS SHOULD THE ENGINEERING COLLEGES GRANT CREDIT FOR HIGH SCHOOL DRAWING?

by

R. R. Worsencroft  
University of Wisconsin  
Madison, Wisconsin  
December 27, 1947

On the question of developing a basis for granting credit in engineering drawing, this paper deals primarily and exclusively with high school drawing. It does not take into consideration any other experience which applicants for credit might have had in addition to, or instead of high school drawing. Such other experience as practical commercial work, vocational and trade school courses, A.S.T.P. or Navy courses, and college transfers, all must be considered on their own differing merits. We are concerned here only with the applicant for credit who believes he has had enough high school drawing to qualify for exemption from elementary courses in engineering drawing. Descriptive geometry is not considered as being an elementary course.

The contents of this paper, and the conclusions arrived at are largely the results of a questionnaire circulated early this month to a cross-section of about 40 colleges in all sections of the country, and from which some 37 replies were received.

Before attempting to evaluate credits for high school students, let us first try to determine the standard by which their preparation in drawing must be judged. Let us try to define a "college level" course in engineering drawing in terms of what the student is expected to have acquired from it.

First and foremost, he should have a thorough knowledge of, and proficiency in ordinary orthographic projection. He should have acquired the ability to select properly and construct correctly the orthographic views of a mechanical object from either the object itself, a pictorial drawing, or a rough sketch. He should be able to read orthographic drawings of both detail and assembly types, to visualize the shape of the part depicted, and to locate all information necessary for its construction. His visualizing ability should be well enough developed for him to take up successfully the more advanced principles of descriptive geometry.

Second, he should have a fundamental knowledge of drafting conventions, standards, and dimensioning. He should be familiar with sectional views, both as to their use and construction. He should be acquainted with the standardized conventions of the American Standards Assn., such as screw threads, bolts, nuts, screws, gears, etc., and be able to employ them in their proper place, and draw them correctly. And then he should have a thorough grounding in the "technique" and "placement" phases of dimensioning, together with the basic principles of the "selection" phase, which latter, of course, involves at least a small amount of shop information and practice.

Third, he should have acquired the manual skills necessary for a reasonably good drafting technique. Such skills would include ability to do lettering of good quality in the standard types recommended by the A.S.A. (vertical caps, and slant upper and lower case); ability to handle a drawing pencil, and execute a pencil drawing neatly and efficiently, using proper and uniform line weights in their correct variations; ability to use inking instruments in making simple ink drawings on tracing cloth.

Fourth, and probably most important to his development as an engineer, he should, by the end of his course, have acquired some ability to work on his own initiative; to apply the theory he has learned to the problem at hand; to make his own decisions as to how a job is to be done, and then go ahead and do it. He should have learned to seek his instructor's help on those things he does not understand, and to act on the advice of his teacher rather than upon his explicit directions. In short, he should have made a start on learning to think for himself.

Now, I would have you note particularly, in this brief outline, the emphasis placed on fundamentals, and the importance attached to a thorough knowledge of them. This is one characteristic of a college level course. It is a planned course - a course planned to build principles, block upon block, until the student has mastered them and their inter-relation with one another. Its primary objective is to build knowledge - only as a secondary objective can student interest be considered. Thus the interesting side lines and tempting blind alleys, such as cam design or architectural drawing are allowed to take their proper places in later design courses.

Our student is expected to acquire these abilities from his engineering drawing over a period, at most, of two semesters, and often of only two terms. This is another characteristic of college level work, and college expectation of achievement. The student has a lot of knowledge to acquire in four years, and his mental processes must be keyed to the proper tempo. Your successful freshman attains a new maturity of thought and action in his college work. Often for the first time he feels that he is progressing along that road of accomplishment which he himself has chosen. He is free from the petty disciplines and strict control of the high school classroom. He learns that it is up to him to prove his worth, and college type teaching encourages this belief.

How well do the high schools prepare our engineers to omit such a college level course in drawing? The fact is that they do not prepare very many of



them, for the great majority of our freshman engineers must start drawing from scratch in college. Estimates from the questionnaires indicate that only 38% of the entering freshmen have had some high school drawing. A more concrete example, and typical of the Central states is the University of Michigan. Of their students enrolled in elementary drawing, 4/7 have had none or less than one year, and 6/7 less than 2 years of high school drawing. These small percentages may be accounted for by two reasons.

In the first place, comparatively few high schools offer drawing courses. For example of 458 high schools in Wisconsin, no more than 125 have trained industrial arts teachers, and not all of these schools teach drawing as a separate course. This proportion of approximately 1 in 4 teaching drawing should be about average for the whole country, as the greater preponderance of drawing in schools in urban and industrial areas should be offset by the absence of drawing in the great number of rural schools.

Secondly, a great majority of prospective college students have very little idea of the type of work they will take up in college, and so in high school, they pursue studies that will enable them to satisfy the general entrance requirements of the colleges. Needless to say, this does not often include a major in drawing. As a corollary to this, we may note that most college entrance requirements are such that little spare time is left in the high school curriculum for an adequate course in drawing even if it is available. Thus, college instruction in drawing must start at the beginning level.

When we attempt to evaluate the drawing offered by the 38% who have taken this work in high school, we get a very confused picture of the status of high school drawing as far as college credit is concerned. Many different factors are involved. In this section of the paper, I shall draw largely on the comments to question 5 of the questionnaire, to which there were 23 answers.

To begin with, there is the quantity factor. How much drawing should the high school student have had? The questionnaire offers little information here. Of the three schools that indicate they would consider applicants on certification, two require two years, one requires 4 years. If we apply the rule of thumb that a year of high school is the equivalent of a semester of college, then two years of high school drawing is the absolute minimum for consideration for elementary engineering drawing. But other time factors enter. When did the student have his drawing - in the first two years of high school? If so, the chances are that he has forgotten most of it, due to his youth and immaturity, and his lack of appreciation of the importance of the course would have in his college years. Four answers to question 5 indicate directly that the high school student is too young and immature to have profited by his drawing, and several others imply it. Has there been any great lapse of time between high school and college? A high school student tends to forget his drawing far more quickly than the college student, for the latter will be using parts of his drawing in other college courses, while the former will find no occasion to remember it in the

period between college and high school. With three years of drawing, ending in his senior year, we might consider the omission of elementary drawing as far as the quantity factor is concerned.

But there is also the quality factor to be considered. Part of this quality factor is the high school teacher. What kind of a teacher gives the courses in drawing? Seldom is he an engineer or an engineering graduate. Three answers to question 5 say that high school courses lack the engineering viewpoint. This is one reason. Is he a trained industrial arts teacher, giving a carefully planned and developed course? This is our next best choice, and this may be the case in large city schools, or technical high schools. But when drawing is taught in the smaller high schools, it is too often the teacher with the lightest teaching load - the art teacher or the football coach - who gets the job. Assigned to a task outside their educational orbit, they are neither interested in it nor qualified to teach it. But why should they do anything about it - next year the biology teacher may get the job. Even three years of drawing under such instruction has little value as far as college credit is concerned.

Even in high schools where good and competent instruction in drawing is provided, the suitability of the course for satisfying engineering drawing requirements is questionable. Many such high school courses are pointed emphatically, and probably quite correctly so, in the direction of vocational guidance. Their objective is to illustrate the value of drawing in ordinary life situations, and perhaps, going further, to give those students who become interested in it, some conception of the work done by draftsmen and mechanics. Three answers to question 5 report that high school drawing is largely vocational in character. Thus such schools attempt to cover the whole wide field of drawing, giving their students a little taste of all kinds, hoping to guide them into some field of interest. Needless to say, a sip here, a taste there is no way to satisfy the requirements of the college drawing course I have previously outlined. The most frequent comment to question 5 indicates that high school drawing is weak in teaching basic fundamentals. Twelve out of the 23 who answered made this statement.

Then there are the courses usually, but not always given by the art teacher or football coach. They have no point and no value; they are the well known "copy" courses, where the students busy themselves turning out lovely copies of their problems, but at the conclusion of the course, have no more idea of what it is all about than when they started. Some five comments from question 5 say high school courses are largely copy courses - geometric and instrumental exercises. Certainly these would not meet with college credit approval.

And finally, in some few instances, we find schools and instructors that plan, develop, and teach drawing courses so competently that there is no question but what their better students are qualified to omit the elementary or first course in engineering drawing. Such schools are usually the technical high schools found in the larger cities.

(Continued on page 29)

IT  
 MAKES  
 THEM  
 GIVE  
 WHAT  
 THEY  
 HAVE

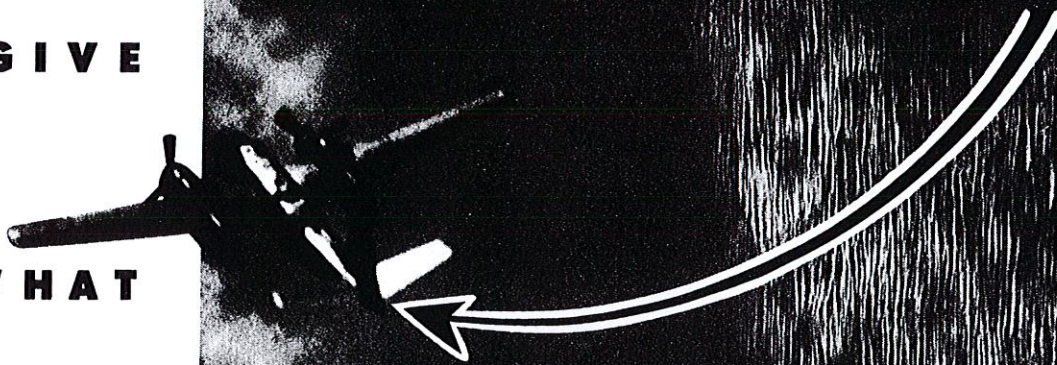

INTERNATIONAL NEWS PHOTO

IN the various rain-making experiments performed by dropping pellets of dry ice into cloud masses, it has been pointed out the rainfall already exists in potential. You cannot conjure rainfall out of atmosphere that has none to precipitate. The dry ice pellets simply make the clouds give what they have. This example dramatizes the whole object of education . . . to make boys and girls "give" what they already possess. All youngsters have energy, ambition in some direction, desire to succeed in some form, the need to unfold their personal possibilities. All youngsters want to make a contribution that brings prestige and respect from the fellows they respect. But too often their talent and abilities are held in suspension, too often inhibited, at dead center, and the individual does not know what to do. The problem is to tip the equilibrium, to cause the flow of energy to start, to give the youngster the impulse down the road he must follow with increasing momentum. It does not matter what work the student is doing. The starting point is anywhere along the line. The instructor in mechanical drafting will find his students most receptive when they first enter drafting class. He can catch their interest at the full, when it is least inhibited. He can start the flow of energy before the student has a chance to "freeze". He can, that is, if he makes full use of the opportunity.

One little example . . . the drawing instruments to which the lad is then introduced and which he may use all the rest of his life. These instruments can be mere "merchandise", or they can be vested with an idea. They can be taken for granted and thus overlooked, thus associated with unwilling discipline, or they can be introduced for what they really

are. In the simplest terms, these tools are tools in the act and art of creation, construction, building, progress. They are equipment by means of which science and engineering benefit the world. Seen sensitively and imaginatively, they are things of beauty in themselves, appealing and compelling because of their functional beauty. But beyond all these things, drawing instruments can be the youngster's road to salvation; training and inspiring him in the disciplines of honest, consecrated work, the full and free gift of his ability to the world.

Drawing instruments are certainly worth time and care in their selection, worth the utmost respect the instructor and then the student can bring them. Surely the best can be none too good.

### EUGENE DIETZGEN CO.

Chicago • New York • San Francisco • New Orleans • Pittsburgh  
 Los Angeles • Philadelphia • Washington • Milwaukee  
*Dealers in All Principal Cities*

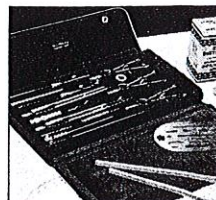

# DIETZGEN

EVERYTHING FOR  
 DRAFTING AND SURVEYING

**MILITARY GRAPHICS\***  
**Instruction in Engineering Drawing**  
**and Military Topography at West Point**

by

Col. L. E. Schick

I know that one appearing on the program of an A.S.E.E. meeting is expected to make some rather profound pronouncements. Delegates come to these meetings to get something to take home. The ideal platform performance unlocks some mystery, propounds or solves a grave problem, reveals a fresh viewpoint, or in some other way contributes to the advancement of knowledge or teaching.

I declare my inability to do any of these things. I must justify my presence on lesser grounds. I did not have the alertness to decline the surprising telephone summons from Professor Paffenbarger; besides I think I owe him something anyway and intuitively felt that he was giving me a chance to pay him back at your expense.

I was asked to choose my own subject. I selected the one you see on the program because it is my subject. It comes closer to being a specialty with me than anything else. In appearing before you I feel more as though I were rendering a report of stewardship to the taxpayers than presenting ideas which may be of some professional help to others, and you are the particular group of taxpayers most able to judge my particular activity.

So, in discussing my subject I will not be trying to convince you of the excellence of any new ideas, but rather informing you how we handle our graphics instruction at West Point. This is for your information. You represent the stockholders, but I hope this won't be known afterward as a "meeting of the bored." I shall talk about the Department of Military Topography and Graphics - its objectives and how we try to meet them.

West Point looks to higher echelons in the national governmental structure for its mission. Here we are at once on a different footing than most schools; however, I presume state universities have a somewhat similar relationship with their state governments. The Academy is expected to produce graduates who have specific value to the Army. The Department of the Army prescribes its mission. It does so in a succinct statement which we consider to be a very enlightened, intelligent paragraph. The author is one of the anonymous regulation

writers who occasionally rise to exceptional literary and philosophical heights.

"Mission. - The mission of the Military Academy is to instruct and train the Corps of Cadets so that each graduate shall have the qualities and attributes essential to his progressive and continued development throughout a lifetime career as an officer of the Regular Army."

\* \* \*

"Courses of instruction. - In general, courses of instruction and training will be designed to develop character and the personal attributes essential to an officer, to provide a balanced and liberal education in the arts and sciences . . . ."

This is the cornerstone of our academic and military program. Stemming from this mission, the Academy's curriculum is designed by its own Academic Board and its principal components are subject to the approval of the Department of the Army. The Congress keeps its eye on things at the Service Academies by means of Boards of Visitors composed of members of Congress, leaders in education and industry, and carefully selected officers of the Armed Forces. In addition to this, the institutions are under the eagle eye of John Q. Citizen, who may comment about what he sees or hears without restraint - on the air, in the press, and on the street corner. I needn't remind you that this priceless prerogative of citizenship is freely exercised.

Having been given our mission, we look at the "life-time career of the Regular Army officer" to find out what he needs in the form of a liberal education in the arts and sciences, and in this our procedure is no different than yours. Your curriculum designers keep their fingers on the pulse of the engineering and scientific world; we keep ours on that of the Army.

The Military Academy in turn states an objective for each component of its organization, both academic and tactical, based upon the broad directive I quoted. That given my Department is:

\* Talk presented at the Mid-winter meeting Engineering Drawing Division--January, 1949.

"To give cadets a sound, general knowledge of topography and of graphics which will aid them in the pursuit of technical and military courses of instruction and be of practical use to them in their careers as Army and Air Force officers."

Here you will note that reference is made not only to preparing for careers as officers, but also to provide a foundation for academic and military courses of instruction which cadets may encounter later in their formalized education. Some of such courses are in the upper class years at the Military Academy, others are found in Service Schools and civilian schools after graduation.

This brings us to the point of the Department's responsibility and procedure in formulating its own plan of action. We are now getting close to the firing line. After looking in several directions we get our cues, we come up with this more detailed statement of objectives:

"a. To give cadets a knowledge of Engineering Drawing and its applications in the military profession; to develop their capabilities for graphical expression in accordance with accepted standards; and to induce habits of orderly thinking and efficient procedure by reading and making technical drawings and sketches. This is the mission of the FOURTH CLASS Course.

"b. To teach cadets to read skillfully maps and air photos of domestic and foreign areas and to give them familiarity with the standard topographic and photogrammetric equipment and processes employed in the production of U. S. Military Maps, Charts and Sketches. This is the mission of the THIRD CLASS Course."

The title "Military Graphics" merely connotes those branches of graphics which receive the widest use in the military setup and actually there are few not thus employed. But, in our descriptive geometry course, for instance, we give a sizeable block of time to map projections. You will recall that the older texts nearly always included a discussion of this subject - most omit it now. Map projections are of increasing military importance. A properly educated military man should know something about them.

And I may as well classify topography, our second year course, as an element of military graphics. The subject deals extensively with graphical delineations - getting the information to use in making a map - actually making the map - or using the completed map. The topographic map is the kind which is of primary military importance - it is a 3 dimensional affair. In my Department

we spell MAP in capital letters. It is our main concern. It is one of the most important and most widely used of all graphical forms. I think I would be justified in actually calling my Department simply "Military Graphics."

At this point I wish to refer to the chart that is before you. You who are chart analysts may have detected already a fault in the chart's construction; viz, it is not entirely intelligible without more explanation than appears within its borders. But, I expect to overcome that deficiency with the explanations which follow. This violation of a basic principle was premeditated. If the chart were entirely self-explanatory, there would be little need for my commenting upon it. So, for the occasion, perhaps it is suitably designed.

This furnace-like structure represents a cadet and the cumulative time effort that our Department puts into him. We start pouring things in at the top and continue adding ingredients throughout two years. The black arrows denote theory; the white arrows within the furnace indicate the various applicatory or annealing processes that are performed. The width of the component lines represents proportional time in a general way. Detailed breakdowns have been omitted in an effort to keep the demonstration from becoming unduly confused. At the end of the process, in the bottom of the furnace, the results of our efforts collect. They consist of certain amounts of appreciation, familiarity, knowledge, facility and skill, which I will describe later.

Now let us go back a moment. To determine what we must teach, what we are to pour into this furnace, we must examine other undergraduate and post graduate courses of study, as well as the professional career, to see what our requirements are. Our courses are given the first two years; their location in the curriculum permits their serving later courses in other departments. Mr. Carl Svensen, one of the deans and mentors of Engineering Drawing, put this same idea excellently when he said in his speech on Engineering Drawing at Austin last summer: "It is at once a service subject for study in acquiring an engineering education and for use in the practice of the profession of engineering after the education is acquired." The graphics course finds its counterparts in the standard freshman Engineering Drawing and Descriptive Geometry courses in other schools. The Topography course is quite special with no direct counterpart anywhere - not even in service schools.

(EXPLAIN FROM CHART)

Now a word about our results. I referred to the five words down here near the  
(Continued on page 24)

### COURSE COMPONENTS AND OBJECTIVES

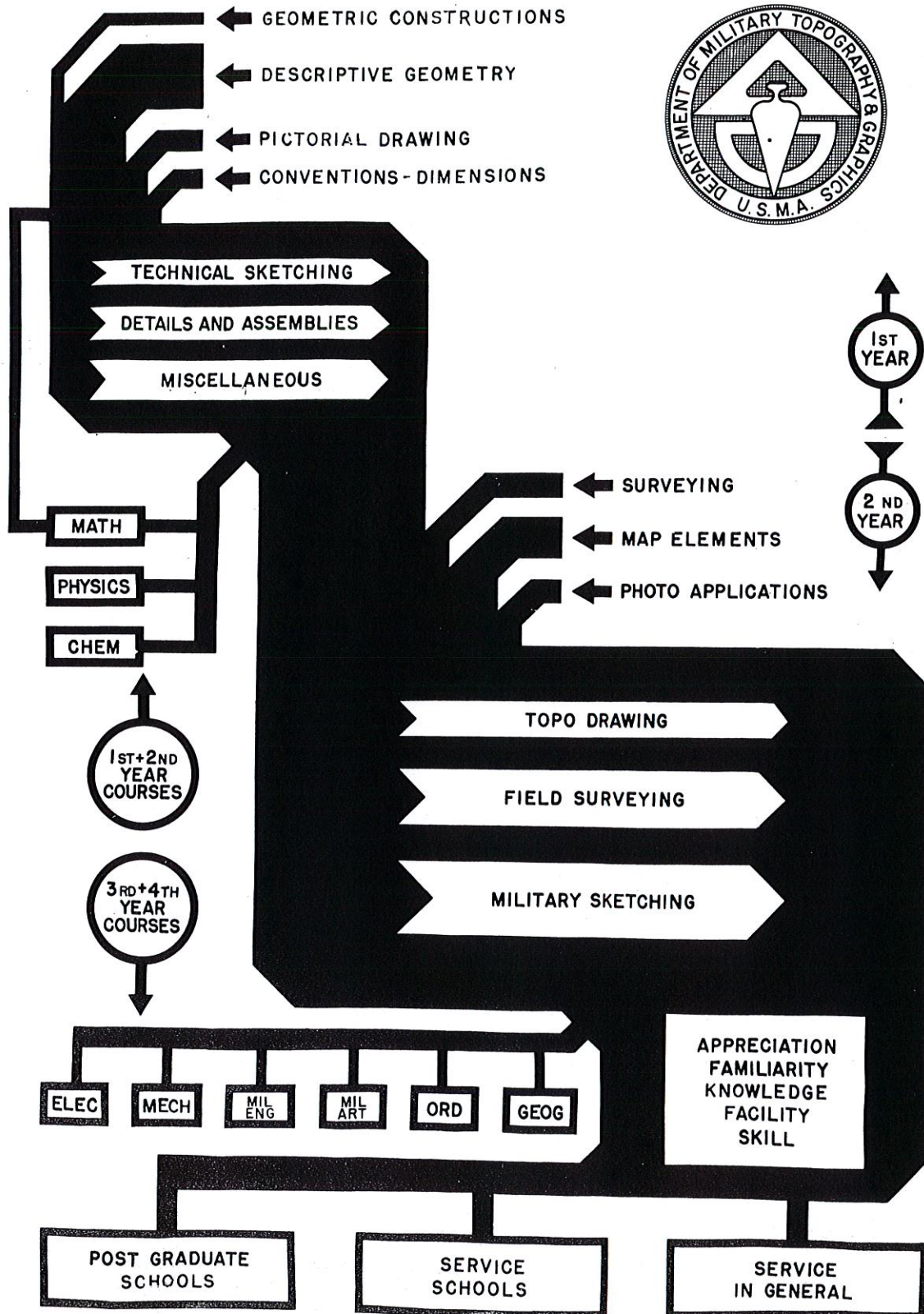

# VAN NOSTRAND FOR COLLEGE TEXTS

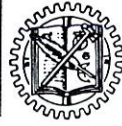

## ENGINEERING DESCRIPTIVE GEOMETRY

By CHARLES ELMER ROWE  
*Professor of Drawing and  
Assistant Dean of The College of Engineering,  
University of Texas*

THIS POPULAR TEXT follows the *direct method*, which the author believes makes the subject more interesting.

MORE THAN 1000 PROBLEMS furnish excellent practice for the student. Very detailed attention to shades, shadows, and perspective. *Particular emphasis* is placed upon orientation which aids the student in developing powers of visualization.

CHAPTERS COVER: Principal Views; Auxiliary Views; Oblique Views; Line and Plane Problems; Surfaces and Developments; Surfaces and Intersections; Warped Surfaces; Geology and Mining Problems; Engineering Problems; The Mongean Method of Descriptive Geometry; Shades and Shadows; Perspective Drawing; Problems; Index.

299 pages—Cloth Bound—6x9—**\$3.00**

ENGINEERING DESCRIPTIVE GEOMETRY PROBLEMS—Series A—(Rowe and McFarland) 106 pages—Paper—Loose Leaf Binding . . . . . \$2.50

ENGINEERING DESCRIPTIVE GEOMETRY PROBLEMS—Series B—(Rowe and McFarland) 108 pages—Paper—Loose Leaf Binding . . . . . \$2.50

## TECHNICAL DESCRIPTIVE GEOMETRY

By PROFESSOR WILLIAM E. STREET  
*Head of The Engineering Drawing Department,  
Agricultural and Mechanical College of Texas*

NEW APPROACH for the subject is used in *this* text which develops the draftsman's method of treatment in obtaining size, shape, and position of every detail of structures and machines.

CONTENTS: Projections; Primary Auxiliary Views, Successive Auxiliary Views; Revolutions; Developments; Intersections; Perspective; Shades and Shadows; Force Diagrams and Loaded Structures.

ILLUSTRATIONS AND PROBLEMS are arranged in progressive order depending upon the method of solution. Grouped for easy transition for the student who has had one year or more semesters of college drawing as follows: *first*, illustrations using straight orthographic projection; *second*, illustrations involving primary auxiliary projection; and *third*, those using successive auxiliary projections.

179 pages—Well illustrated—**\$2.75**  
9¾ x 7—Cloth . . . . .

TECHNICAL DESCRIPTIVE GEOMETRY PROBLEMS (Street, Perryman, and McGuire) Designed to relieve the student and teacher of much unnecessary layout work. 79 pages—Loose Leaf—Paper Bound . . . . . \$2.50

## ENGINEERING DRAWING PROBLEMS

*A Manual Which Can Be Used With Any Standard Text In The Field*

By ELIOT F. TOZER and EUGENE G. PARE  
*Northeastern University* and *Illinois Institute of Technology*

Provides a sound, basic course in engineering drawing with no prerequisites required. Furnishes the student with a firm foundation for future courses in Machine Design, Machine Drawing and Structural Drafting. Contains 48 pages for student reference from the American Standard Drawing and Drafting Room Practice. 160 pp. Illus. Paper Bound 11x17. **\$3.25**

EXAMINATION COPIES PROMPTLY SENT UPON REQUEST. WRITE TODAY.

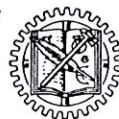

**D. VAN NOSTRAND COMPANY, INC.**

PUBLISHERS SINCE 1848

250 FOURTH AVENUE

NEW YORK 3, NEW YORK

## THE LOGIC OF VISUALIZATION

by

B. Leighton Wellman  
Worcester Polytechnic Institute

A paper presented at the Fall Meeting of the New England Section, American Society for Engineering Education, on October 16, 1948, at Northeastern University, Boston, Massachusetts.

"He's a good student, but he simply cannot visualize." Probably every drawing teacher has had occasion to make that statement at some time. I said it too some years ago, and repeated it quite a few times before I began to realize that there was something strangely incongruous about the statement. What did I mean by saying, "he cannot visualize"? Simply that he cannot read a multiview drawing. And what makes me think he is a "good student"? Because he has good grades in mathematics, physics, and chemistry. But a mastery of these engineering science subjects certainly requires a mind capable of orderly, logical thinking; hence it is a fair assumption that in general this student can think, that he can reason, that he can recognize facts, and finally that he can draw correct conclusions from clearly stated facts. Such students are not common, but they do occur frequently enough to cast suspicion on the teaching methods of the drawing teacher.

Visualization from an engineering drawing must be taken out of the realm of black magic and put under the solid yoke of analytical reasoning. There must be no guesswork or flights of imagination, no need for hunches or flashes of intuition. The whole process of reading an engineering drawing can and should be based on logical conclusions derived from accurate observation and orderly reasoning. Visualization of the object is only the final step in a tightly interwoven chain of reasoning. Thus visualization must follow, not precede, reasoning.

What is this logic of visualization? What are the thoughts that run rapidly, almost subconsciously, through the mind of an experienced draftsman when he reads a drawing? If someone would invent a high-speed camera for photographing such thoughts, we might then find the solution to our greatest teaching problem. Of course we can interview the draftsman and ask him how he did it, but unfortunately he has been doing it for so long that most of his thinking is now subconsciously and very rapid. What he tells us is only a superficial and fragmentary description of the complete train of thoughts that passed through his mind. Like the iceberg ninety percent of it is still hidden below the surface.

The engineering drawing teacher is apt

to find himself in the same predicament; years of experience have taught him how to read a drawing, but now he does it so fast that he isn't quite sure just how he did it. Furthermore, he has seen and studied so many "mutilated block" problems that it is difficult to tell how much of his reading is sheer memory and how much is real analytical thinking. Only on those rare occasions when he discovers a new and different problem is there an opportunity for him to watch his own mind in action. His situation then becomes similar to that which confronts the beginning student.

If we could look inside the thinker's head, and watch his thoughts as they form and grow and tumble out of his gray matter in rapid succession, we would probably find that it isn't an orderly parade. Some thoughts are advancing steadily, but many others are surging back and forth on the edges of the column, and many are rejected and fall by the wayside. In spite of this confusion, however, the column of thoughts is moving forward, and I think we might begin to recognize the main elements in this thought parade. Let us catalog these main elements in their order of appearance:

1. The Overall Survey. The reader glances at each of the given views in rapid succession noting only approximately their general shape and outline.

2. The Search for Familiar Elements. He looks for old friends, something familiar, something similar to what he has seen many times before such as a pulley, a gear, a bearing, a tapped hole. This is rapid recognition based upon experience--an ability dependent chiefly on memory and long practice.

3. The Search for Familiar Geometric Solids. More old friends, the cube, the prism, the cylinder, etc., now are recognized, especially those that protrude into space from the main body of the object. The simple solids the average student learns to recognize very early in the course.

4. The First Correlations. Familiar and prominent elements found in one view are now correlated with the corresponding parts  
(Continued on page 17)

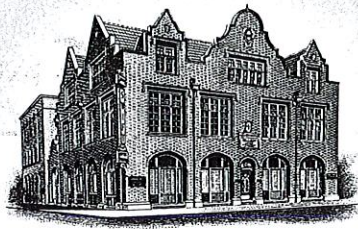

# University Engineering Departments

USE THE

## JOHN S. SWIFT CO., Inc. PLANOGRAPH PROCESS

FOR THE REPRODUCTION OF

**DRAWING SHEETS**



**PROBLEM BOOKS**



**MECHANICAL DRAWINGS**



**MAPS—CHARTS**



**INSTRUCTION MATERIAL**

Your Choice of Binding: LOOSE-LEAF, SEWED AND CASED, WIRE SPIRAL, PLASTIC, ETC.

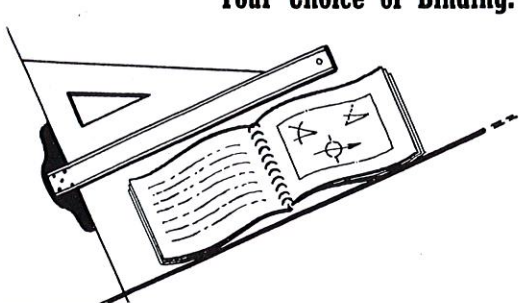

### JOHN S. SWIFT Co., Inc.

OPERATING FIVE PLANTS

|                   |                |                |                  |                       |
|-------------------|----------------|----------------|------------------|-----------------------|
| New York 1, NY    | Chicago 7, Ill | St Louis 3, Mo | Cincinnati 2, O  | Cleveland 13, O       |
| 455 West 30th St  | 17 N Loomis St | 2100 Locust St | 3rd and Vine Sts | 116 St Clair Ave, N W |
| LAckawanna 4-1144 | MONroe 7020    | CHestnut 7141  | PArkway 4148     | PRospect 4488         |



(Continued from page 15)

in the other views. This is chiefly a process of comparing the alignment of the views: a rectangular area in the top view is directly above a similar area in the front view; a circular area in the front view is directly opposite a pair of dash lines in the side view, etc. Visualization usually starts at this stage, and a mental picture begins to form. The picture is hazy, however, and somewhat out of focus for only a few of the component elements have been fully identified and located.

5. The Examination of Surfaces. The less familiar solids must now be examined in greater detail, and the search is now focused on the individual plane surfaces that bound the solids. The eye is attracted first to those visible surfaces of odd or unusual shape, and simple rectangular surfaces may be temporarily ignored.

6. The Correlation of Surfaces. The reader is now looking in the adjacent views for the odd L-shaped surface he has found in the front view, and he is carefully considering the triangular area shown in the side view for there are no triangular areas in the front or top views.

7. The Orientation of Surfaces. Conclusions and decisions occur rapidly now as each individual plane surface is identified and located in each view. Which surfaces are horizontal, which are vertical, which are inclined, these decisions are easily made now. By this time most of the visible surfaces have been properly placed, and the few remaining surfaces, chiefly hidden, are easily correlated because they are so few in number. The mental picture is now complete, and the object has been visualized, not by intuition, but by accurate observation and logical deductions.

The above analysis is my own impression of how an experienced draftsman thinks. I am not a mind-reader, and do not pretend to know how every man thinks, but I do believe that the though process outlined here is a logical sequence that can be applied, in whole or in part, to the reading and visualization of any object.

Reviewing the seven stages of reasoning, it will be observed that the analysis proceeds from the general to the particular, from the larger and more obvious elements to the smaller details, from solids to planes. Beginning students frequently attempt the reverse process; they begin by labeling the points or corners of the object. This scheme usually results in complete confusion for there may be four or more points in one view, all of which align exactly with four or more points in the adjacent view. Such a situation can only be clarified by first correlating the various surfaces of which the points

are a part. Thus any analysis should logically begin with the component solids, and then progress to a detailed consideration of the surfaces which bound the solids. Labeling individual points is the last step.

Recognition of the familiar geometric solids is a relatively easy step for most students, but an exacting analysis of the various surfaces seems to be more difficult. Experience has shown, however, that the process of identifying plane surfaces can be reduced to the application of two very simple rules.

Consider first a single view of an object (Fig. 1). Whether this is a top, front, side, or auxiliary view is immaterial.

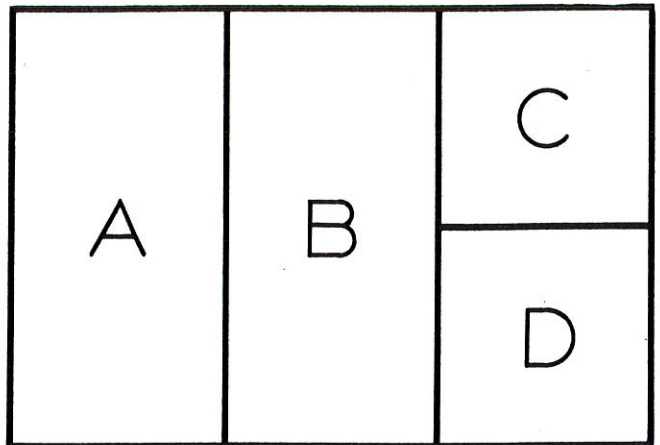

Fig. 1

We shall assume, however, that there are no curved lines in any of the other views, and hence the object is bounded entirely by plane surfaces. Then the four areas A, B, C and D shown in this view represent four visible rectangular surfaces. Because areas B, C and D are each adjacent, or contiguous, to the other two, they must all lie in different planes. If areas C and D were in the same plane then there would be no dividing line between them. Areas A and B also lie in different planes, but area A could lie in the same plane as either C and D, or in a different plane. These facts may appear to be obvious and self-evident, but they are an essential part of any logical analysis, and we can state the rule very briefly as:

The Rule of Contiguous Areas

No two contiguous areas can lie in the same plane.

Consider now the appearance of any plane surface in the various views of an object. The surface in question may be horizontal, vertical, or inclined, but it will always appear in one of two distinctive

(Continued on page 22)

## OUTSTANDING AIDS

*for Engineering Drawing Students from t*

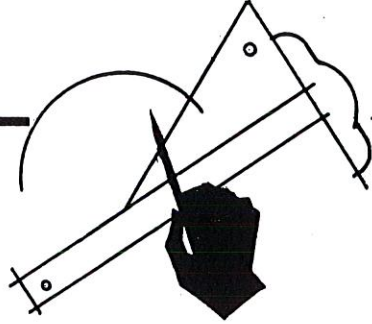

### **Engineering Drawing — 7th Edition**

By the late Thomas E. French, the Ohio State University. Revised by Charles J. Vierck and associates of the Department of Engineering, The Ohio State University. 694 pages. \$4.00

The value of a course in drawing lies in the selection, methods of presentation, and correlation of the problems with assigned study of the text. In this revision many of the favorite problems of the previous edition have been retained and many new ones representing current design have been added. The chapter on illustration and the complete rewriting of the chapter on perspective plus the expansion of the chapter on dimensioning into two chapters will be of tremendous value to the user of this text.

### **Engineering Drawing Problems**

By Charles D. Cooper, Paul E. Machovina and Charles J. Vierck. All of the Ohio State University, arranged for and correlated with French's Engineering Drawing. Series I. \$3.50

Practical, direct and thorough, this book presents a series of problems in the most logical and usable order for first-year classes in engineering drawing. In accordance with a recent survey made by the drawing division of the American Society for Engineering Education, the book includes exercises in all of the subjects usually covered in schools throughout the country.

### **Engineering Drawing Sheets—Series F**

By Thomas E. French, and H. M. McCully, Late Professor and Head of the Department of Drawing and Descriptive Geometry, Carnegie Institute of Technology. \$4.00

These sheets are designed to make the most economical use of time allowed for drawing courses. The careful arrangement of lesson sequence; the increased attention to reading drawings and technical sketching; the time-saving layouts of problems in projections; sections, dimensioning, lettering, working drawings; combine to make a course that compels student interest.

### **Problems in Engineering Drawing — Series II**

By A. S. Levens and A. E. Edstrom. Both of the University of California. Keyed to the 7th Edition of French's Engineering Drawing. \$3.00

This well-known and widely liked workbook has been carefully revised and enlarged from 62 to 72 worksheets. Its primary purpose is to provide, in a minimum number of plates, sufficient practice to enable the student to master the techniques of drawing in accordance with practice established by the American Standards Association.

### **Mechanical Drawing — 5th Edition**

By the late Thomas E. French. The Ohio State University; and Carl L. Svensen, Consulting Engineer. 437 pages. \$2.80

This revision retains all the well-liked features of earlier editions but offers many improvements and much new material. New chapters have been added on aircraft drawing production illustration, and welding drawing.

### **Workbook in Mechanical Drawing An Introductory Course.**

By Shriver L. Coover, Director, Industrial Arts Department, State Teachers College, California, Pennsylvania. 96 pages. \$1.48

The unit structure of this workbook enables each member of the class to progress at his own speed with little help from the instructor. Drawing units are presented in logical order with each unit brief, but containing all the information necessary for understanding the principles involved. Special objective tests, pertinent to life situations and largely self-administering, are included with the various units. Written specifically to save time for both teacher and students, the book is as nearly self-teaching as it can be made.

### **Applied Descriptive Geometry**

*With Drafting-Room Problems — Third Edition*

By Frank M. Warner, University of Washington. 252 pages. \$2.75

Easy to teach, easy to understand, this widely used standard text is well liked because it emphasizes the direct view method; and because it includes a wealth of illustrative problems covering all branches of engineering with engineering settings and data as they occur in actual practice

# McGraw-Hill Book Company, Inc.



## Technical Descriptive Geometry

By B. Leighton Wellman, Professor of Mechanical Engineering, Head of the Division of Engineering Drawing, Worcester Polytechnic Institute. 508 pages. \$4.00

This popular book provides students and industrial draftsmen with a complete up-to-date treatment of the important subject of descriptive geometry. Written in simple language and generously illustrated, the book covers the subject thoroughly, beginning with the most elementary concepts and progressing by easy stages to the complex intersection and development problems found in modern applications. The whole approach to the subject is new. By classifying all views simply as "adjacent" and "related," and emphasizing the direction of sight for each view, the author develops the entire subject simply and logically without reference to imaginary planes and projections.

## Practical Descriptive Geometry—4th Edition

By W. G. Smith, late Professor of Engineering Drafting, School of Engineering, Northwestern University. 275 pages. \$3.00

A textbook for engineering college students which is unique in its collection of problems based on engineering situations.

## Geometry of Engineering Drawing—Third Edition

By George J. Hood, University of Kansas. 362 pages. \$3.00

This pioneer in introducing the direct method of teaching descriptive geometry has been widely adopted. Teachers have discovered that the use of the direct method greatly reduces the number of students who fail or drop their descriptive geometry course. The method used in this book adopts the methods, vocabulary and attitude of mind used by the engineer when he visualizes and designs structures. Problem sheets for this text are available at \$1.50 the set.

## Architectural Drawing for The Building Trades

By Joseph E. Kenney and John P. McGrail, both of the Massachusetts University Extension. 138 pages. \$3.00

Elementary enough for the beginner, this book is designed especially for students who wish to prepare themselves for work in an architect's office. The approach is eminently practical and the approach throughout is on student activity—learning by doing. There is a minimum of text material in the sense of description and explanation; there is a maximum of direction, guidance, and practice.

## Quiz Questions—2nd Edition

To accompany the 7th Edition of French's Engineering Drawing. By John M. Russ, Professor of Engineering Drawing, The State University of Iowa. 50 cents.

A particularly helpful teaching aid for use with the latest edition of French's *Engineering Drawing*. These questions can be assigned students at various intervals and will be found a great convenience to the instructor as a source of quiz and lecture. The pattern of the previous edition has been followed, but improvements in the arrangement of the material have been made throughout.

## The Essentials of Lettering—3rd Edition

By the late Thomas E. French, and Robert Meiklejohn. Oblong, 94 pages. \$1.75

This classic text shows the method of construction of various styles, analyzes the letters, giving the order and direction of strokes, and aims throughout at the snap and swing of professional drafting. The illustrations are of a high grade.

## Lessons in Lettering

By the late Thomas E. French, and William D. Turnbull. Book I—Vertical Single Stroke. Second Edition. 40 pages. 50 cents. Book II—Inclined Single Stroke. Second Edition. 40 pages. 50 cents.

A famous series of practice books with text examples and exercises for students and draftsmen. The volumes save all the trouble of ruling paper for practice, and provide both practice paper and text in one book.

*Send for copies on approval*

330 WEST FORTY-SECOND STREET, NEW YORK 18, N. Y.

**MID-YEAR MEETING  
DIVISION OF ENGINEERING DRAWING  
OHIO STATE UNIVERSITY  
COLUMBUS, OHIO**

January, 1949

O. W. Potter, Secretary

The mid-year meeting of the Division of Engineering Drawing A.S.E.E. was held this year at Ohio State University during the last week in January. It was held in conjunction with the 75th anniversary celebration for Ohio State University.

The Department of Engineering Drawing scheduled a meeting at 11:00 A.M. on Thursday, January 27th, at which time Professor F. G. Higbee of the State University of Iowa gave his lecture on "The History of Drawing." Engineering students, faculty and members of the Drawing Division were all invited to this meeting. Thursday afternoon and Friday were devoted to technical sessions, plant visitations, and open house in the Department of Engineering Drawing. Opportunity was offered to attend class lectures and also to see students at work in the drafting rooms. The plants visited were the Lustron Corporation, Manufacturers of prefabricated procelain enameled steel houses, the Ternstedt plant of the General Motors Corporation, and the Jeffrey Manufacturing Company. These different plants offered a wide range of Engineering practice and was very interesting and instructive. After hours (and miles) of walking thru these plants, everyone was ready to rest and relax when evening came. Friday evening, there was a college banquet to which all were invited.

Saturday, January 29th was the date of the official meeting of the Division. A most interesting program was provided as follows:

|                    |                              |
|--------------------|------------------------------|
| 8:00 to 12:00 A.M. | Registration and open house. |
| 9:30 A.M.          | Executive Committee Meeting. |
| 12:00 Noon         | Division Luncheon.           |
| 1:15 to 4:30 P.M.  | Technical Session.           |

Military Graphics: Colonel L. E. Schick, Head of the Department of Military Topography and Graphics, United States Military Academy, West Point, New York.

Development of Railroad Rolling Stock Specialities. Harry W. Stertzbach, Engineering Consultant, The Buckeye Steel Castings Company, Columbus, Ohio.

Development of Conveying and Mining Machinery. James A. Flint, Assistant to the President - in - charge of Research and Development, Jeffrey Manufacturing Company, Columbus, Ohio.

Trends in the Design of Highway Bridges. Glenn R. Logue, Chief Engineer of Bridge and Railroad Crossings, Highway Department, State of Ohio.

6:30 P.M. Division Dinner.  
Speaker: Dr. Samuel Renshaw,  
Department of Psychology,  
The Ohio State University.  
Subject: The Visual Third Dimension.

The attendance at the mid-year meeting was almost as great as for the annual meeting. There were 80 at the luncheon and 67 at the dinner. At the luncheon exclusive of Ohio State personnel, there were 53 present. All told, there were representations from 24 schools and 11 states.

The papers presented at the technical session were well presented and each speaker in turn held the interest of the audience until the last minute. The dinner speaker presented a talk which was most interesting but somewhat difficult to describe. We learned that we do not see things alike, and that our vision can be trained the same as our other faculties.

The Executive Committee was missing just one member who was unable to attend because of illness. Several non members met with the committee to help in the transaction of the Division's business. Any member of the Division is welcome to sit in with the Executive Committee at any time. The principal business of the committee was the preparation of the program for the annual meeting in June at Rensselaer Polytechnic Institute. Other business was the election, and the preparation of a Constitution and By-Laws for the Division.

This was another most profitable meeting at which time we renewed old friendships, made new acquaintances, and talked shop. I am sure that everyone present was benefited and we are very grateful to the Department of Engineering Drawing of Ohio State University and the University itself for the fine hosts that they were. We all left stimulated to do a better job back

## NEWS ITEMS

As editor of your official publication, I wish to express for members of our division, our appreciation to the engineering drawing staff at Ohio State University. The hospitality and kindness of this group will long be remembered by all who attended the mid-winter meeting of the Engineering Drawing Division. All arrangements were complete. The program was interesting and instructive. Service was excellent.

The following five interesting and significant news items came to the editor's desk from Professor W. E. Street of Texas A. & M. College:

1. The Annual Engineering Drawing Contest will be held the last Saturday in April. Four classes of drawings are provided and a student may enter only one class provided he is recommended by his teacher. Winners are announced at a convocation. A speaker from industry will furnish the program; Professor B. F. K. Mullins is in charge of this work.
2. The Engineering Drawing Department will have a display of student work, foreign drawings, special drawing equipment, etc. on A. & M. College Open House, May 7, 1949. Parents of students and special guests from industry will be on the campus and all departments of the college will have displays and be open for inspection. Professor S. M. Cleland is in charge of this display.
3. The Engineering Drawing Department of Texas A. & M. College is sponsoring the first drawing contest for High Schools in Texas this spring. A unique plan has been formulated to recognize all participants in this contest. Professor R. L. Barton is in charge of the contest.
4. The Engineering Drawing Department of Texas A. & M. College is sponsoring a Drafting Short Course May 5 and 6, 1949. Outstanding speakers from industry are to appear on the program. Professor J. G. McGuire is in charge of this Short Course.
5. The Engineering Drawing Department of Texas A. & M. College will offer eight semester hours of graduate drawing work during the summer of 1949.

The Z-14 Committee on Standards for Drawing and Drafting Room Practice has been re-activated. Professor R. P. Hoelscher is Vice Chairman and Professor R. S. Paffenbarger is Secretary. R. M. Stanton of the American Machine and Foundry is chairman of the Committee. The Executive Section of this committee met in Cleveland on March 10. We can look forward to an interesting report on the activities of this committee from Professor Hoelscher at our R.P.I. meeting.

Harold L. Minkler, Associate Professor of Technical Drawing at Illinois Institute of Technology has been named coordinator of the cooperation programs for his institution.

Also from the Illinois Institute of Technology we were informed that Associate Professor Eugene G. Pare has been appointed Assistant Dean of Student Affairs.

In another part of the magazine you will find a request from Jim Rising and his committee for drawing display and outlines of drawing courses for the annual meeting. ACT NOW!! It takes time to assemble material of this kind. Those who attended the Engineering Drawing school and convention in 1946 found this a very interest adjunct to our program.

The secretary's report of the mid-winter meeting is significant. During the last two years, the mid-winter meeting has approached in size, our annual meetings. This seems to indicate a significant interest and enthusiasm on the part of our members.

Justus Rising, chairman of Constitution and By-Laws Committee, presented a report on "Articles of Procedure of the Division of Engineering Drawing" at the mid-winter meeting. The report was discussed. It was good. With minor changes, this report will be submitted for adoption by the division at the annual meeting this summer.

(Continued from page 17)

ways: either as a line or as an area. When it appears as an area it may appear in its true size and shape, or the surface may be so inclined that its true shape is distorted in one or more of the views. In either case, however, only the angles and length of the sides are changed; the number of sides and their general sequence is not affected. Thus in Fig. 2 a triangular surface always appears

(3) Areas A and B are each trapezoidal in shape. There are no trapezoids in the front view, hence areas A and B must represent surfaces that appear edgewise in the front view.

(4) Areas C and D are rectangular, and area E is L-shaped. There are no areas of similar configuration in the top view, hence

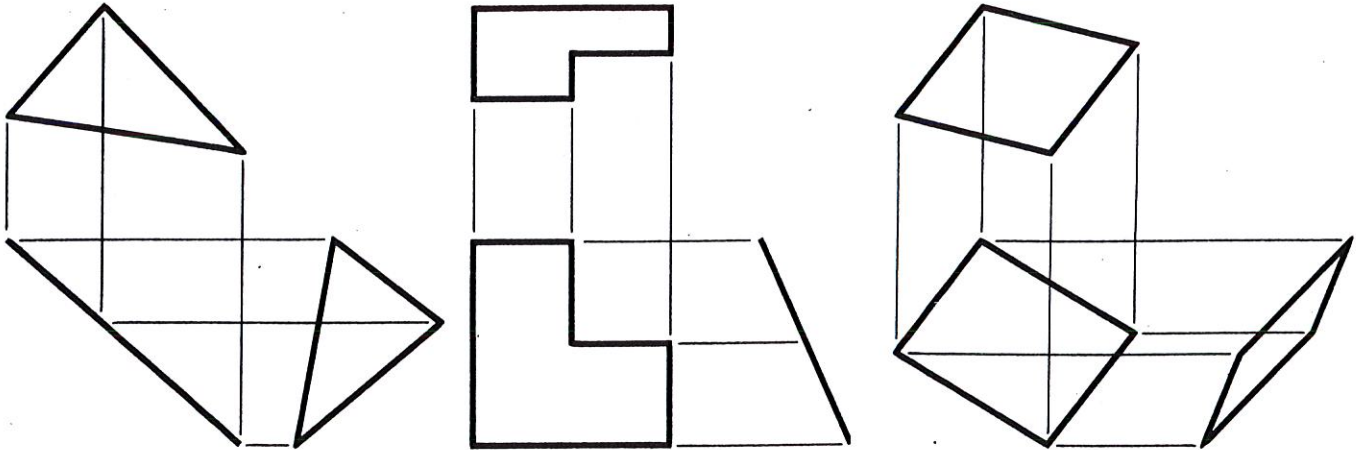

Fig. 2

triangular, never four-sided; an L-shaped surface may appear of different size and shape, but it still retains its characteristic L-shaped outline; a rectangular surface may appear as a parallelogram, but parallel sides remain parallel. These simple but useful facts can be summarized in a second rule:

#### The Rule of Configuration

All plane surfaces, regardless of shape, always appear either as an edge or as a figure of similar configuration.

In order to illustrate the use of the two rules stated above let us apply them to the visualization of a simple object (Fig. 3). This object is admittedly very simple, but the process is exactly the same for more complicated objects. In the following analysis it should be noted that every conclusion is the result of logical reasoning: at no time is it necessary to guess. Complete and exact visualization is the inevitable result. Examining the views, the facts and conclusions develop in the following sequence:

(1) There are no curved lines in any of the views; therefore, the object is bounded entirely by plane surfaces.

(2) The two contiguous visible areas A and B in the top view must lie in different planes. Similarly, visible areas C, D and E are mutually contiguous, and therefore lie in three different planes.

areas C, D and E must represent surfaces that appear edgewise in the top view. Therefore, C, D and E are all vertical surfaces.

(5) Area F is the only visible area in the side view. It is L-shaped, hence similar in configuration to area E. Since there are no trapezoids or rectangles in the side view, we can only conclude that areas A, B, C and D all appear here as lines.

(Continued on page 35)

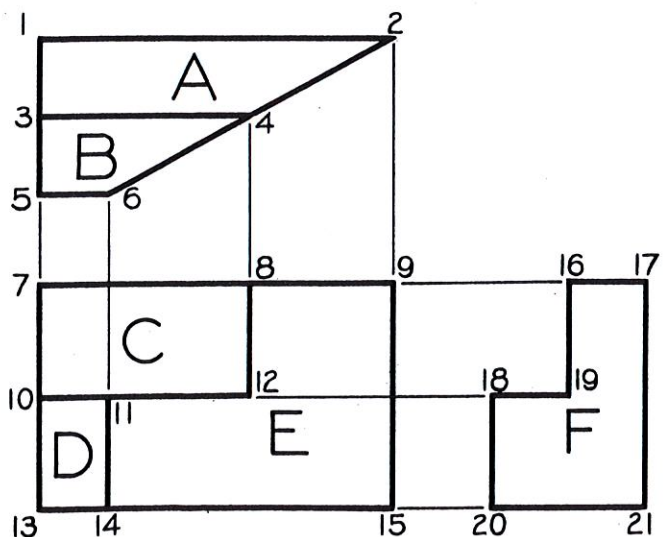

Fig. 3

*Quality....*



# DRAWING MATERIALS

DRAWING INSTRUMENTS  
IN SETS

DRAWING AND  
TRACING PAPERS

WATERPROOF  
DRAWING INKS

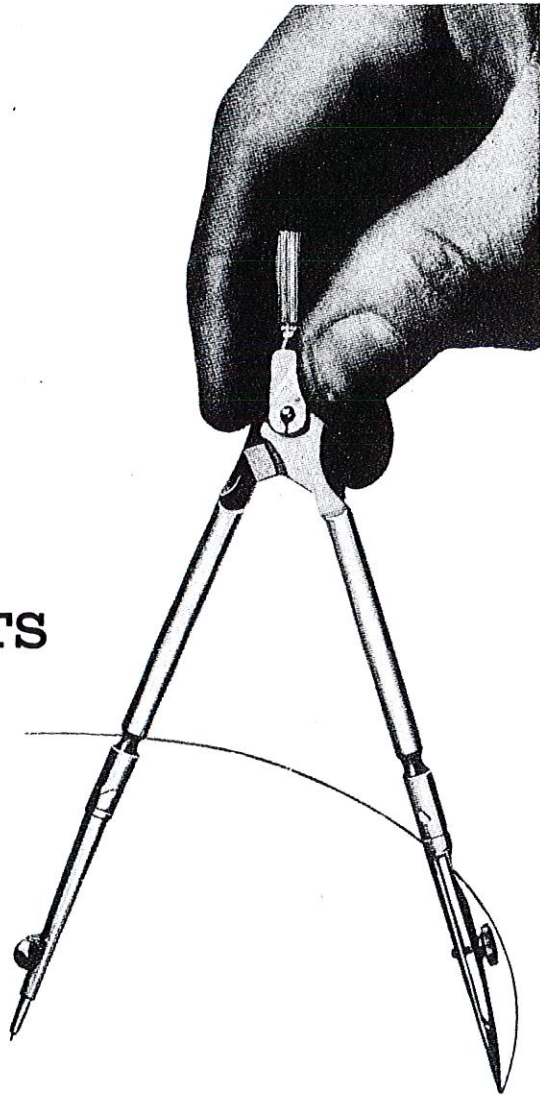

STUDIO, SCHOOL AND  
DRAFTING ROOM FURNITURE

Catalogue, Vol. 700, on Request

## F. WEBER CO.

FACTORY ADDRESS:  
1220 BUTTONWOOD STREET  
PHILADELPHIA, PA.

Branches:

705 PINE ST., ST. LOUIS, MO.  
227 PARK AVE., BALTIMORE, MD.

(Continued from page 12)

outlet taps. To explain these more fully a little background must be stated. Of course, we don't have enough time. Our objectives must be achieved in about 360 classroom hours. That is only forty-five 8-hour working days, but we spread this over two academic years - 2 hours every other day. One half for Graphics - One half for Topography. Most of you have more time for an equivalent coverage. We looked around to see who might be equally harassed by time shortage and found the Engineering Drawing Department of Cooper Union in New York City struggling under almost an equal limitation. So, we put our heads together and found, to our surprise and delight, that our attempts to solve our respective problems ran very similar courses. Obviously we can't go into everything exhaustively. It is possible to arrange things in categories of relative importance - some things must be thoroughly learned; other things must be known about with an understanding of their relationships to the world's work and society. In handling this classification or priority problem we found ourselves using these terms so they became our fixtures. The basic policy declaration of the Department defines them as follows:

#### "Definitions and Evaluations.

a. In planning to achieve these various objectives it is necessary to make an evaluation of the relative importance and attainability of their components. The following analysis serves to scale the degree of thoroughness with which the various elements of our courses should be mastered by each cadet. Regarding Engineering Drawings, sketches and maps, each cadet must achieve the following to attain one of the essential components of his 'broad basic military education' and a foundation for 'his progressive and continued development. . . as an officer . . . '.

- (1) An appreciation of their importance and use in the military profession.
- (2) Familiarity with the background for their construction (analysis, measurement, calculation), and with the engineering and military functions in which they are used.
- (3) Knowledge of the theories of drawing.
- (4) Reasonable facility in making them.
- (5) Skill in reading them.

"Analysis. Each of the achievements expected of cadets with regard to Engineering Drawings and Maps is amplified below:

a. "An appreciation of their importance and use in the Military Profession." Herein lies the motivation and interest factors for our entire effort. Cadets must be informed of the extensive employment of technical drawings and maps in every branch of military endeavour. They (especially since they are plebes when starting our courses) have no orientation on this matter. In introductory lectures and throughout the courses the application of graphics and topography to their own careers as students and officers must be demonstrated convincingly.

b. "Familiarity with the background for their construction (analysis, measurements, calculation), and with the engineering and military functions in which they are used."

- (1) This involves an appreciation of 'what is behind' the drawing and map; the tasks of the inventor, the research man, the designer, the ordnance project engineer, the topographic surveyor, the geodesist, the photogrammetrist, and others. Obviously our excursions into these fields are limited. In most cases they do not go beyond pointing out the kinds of analysis, measurements and calculations required to produce the design, drawing or map. In some cases, however, our objectives are best served by more emphasis. For instance the work of the topographic surveyor is dwelt upon more than the work of the photogrammetrist because it is more fundamental in character and because topographic surveying develops terrain sense, one of our important goals. Also here is the 'area' in which the underlying relationship of the basic sciences to the drawing can be demonstrated, i.e., the place of physics, chemistry, mechanics and electricity in designing such things as breech blocks, military bridge trusses, radar equipment, projectiles and guided missiles, automotive equipment, aircraft, runways, gasoline fueling systems, etc. and the fundamental importance of mathematics in all engineering. We are not creating machine designers, topographic engineers, or even draftsmen. But recognition of the scientific and technical problems confronted by the people 'behind the drawing and map' is important to an educated user thereof.

- (2) One cannot read Engineering Drawings intelligently without



having some understanding of the production process they are made for as well as a familiarity with their genesis. The purpose of the drawing must be grasped. The sequence of 'idea, design, drawing, production, maintenance, revision, modification' must be explained. Material production, the work in the field and shops, the processes employed by the people 'ahead of the drawing and map', compels the use of many idioms in the drawing lexicon which are not imposed by the processes of designing alone. These idioms as well as those used purely for representation must be known before one can read Engineering Drawings comprehensively.

c. 'Knowledge of the theories of drawing.' Without background of this kind also, drawings cannot be fully intelligible. This imposes the requirement for teaching descriptive geometry and presenting an orientation as to the origins and development of the principal types of representation used in drawing and map construction. The various pictorial forms, the 'exploded' views, etc. are based on theories that must be understood. Since in the classroom we employ the expedient of making drawings in accomplishing our objectives a knowledge of the theories of drawing is imperative.

d. 'Reasonable facility in making them.' An officer is of necessity an intelligent 'doodler'. A quick sketch saves hundreds of words and, if well made, communicates ideas quickly with positive clarity. In explaining a route, in directing some rough construction, in locating military positions in initiating ideas for the modification of material, in setting forth data in graphical form, in illustrating reports - in a thousand ways, the facile sketcher or draftsman expedites his professional business. Few graduates of USMA will engage in making the finished types of engineering drawing or map, but the principles used in sketches will be the same as those employed in careful instrumental work. Consequently, practice in the latter as an instructional expedient is important. The construction of engineering drawings and maps requires orderly thinking and efficient manual procedures besides stimulating familiarity with the idioms employed. It is a valuable exercise as a general education factor. Therefore, our efforts are bent toward the goal of perfection in drawing. There is no 'limited objective' of our advance in this direction. The greatest facility possible must be achieved by each cadet within the limits of his capacity, capabilities and time. It is intended that the facility of the least adept will be at least 'reasonable.'

e. 'Skill in reading them.' This is our prime objective. A skill is acquired only with much experience, numerous repetitions. 'Skill, improvement with practice, is directly proportional to the number of repetitions, not, as implicitly assumed, proportional to the time spent.' - (Johnson O'Connor). Repeated exercise in reading drawings and maps accompanied by developing a facility in making them is the best way of producing in cadets the skill desired.

f. 'The foregoing defines the core of our instruction program.' Every phase of our work must be geared to it. Diversions into interesting bypaths are not justified unless they definitely contribute to the overall pattern. Each subject must be logically a part of one of the five objectives or it does not deserve a portion of our very limited time."

Every portion of instruction is weighed against these five definitions and is given time and space according to its merit in the general picture. This catalog serves us well when time shifts confront us. If required to do with less time, as would be the case in a wartime program, we would probably be able to cut back by eliminating some of the items in the "familiarity" category without disturbing the "facility and skill" brackets. As time is reduced, our work becomes more an effort to equip graduates to do the service job confronting them immediately upon graduation, with much less broadening and background material. For instance, the "history of cartography" would be of little importance in preparing a man to become a combat platoon leader in the shortest possible time. But this and many similar subjects are in our peacetime structure because now we are concerned primarily with education for lifetime careers.

So much for our program. I presume that anyone who is concerned with teaching soon adopts or invents some precepts which he considers of fundamental importance. I have a few which I feel urged to recite. They are generalities which find specific application in our teaching. The first is an adopted one pertaining to that mysterious aptitude called spatial visualization. Its possession is not an entrance requirement. We struggle with many cadets who are endowed with only the tiniest modicum of this precious quality, and we have the greatest sympathy for those who must battle our courses with this handicap. We are cautious about discharging for failure in graphics, making sure before doing so that the trouble with the deficient cadet is not exclusively the lack of spatial visualization. Indeed, its lack is really not a sufficient cause for deficiency in our courses. There is usually some other reason. We see some sense in the contention of Tracy and North

of Yale in their commendable Descriptive Geometry text published in 1914: "More than one great mathematician has been lacking in the power to visualize, and in descriptive geometry success does not depend upon this particular form of imagination to the extent that is frequently supposed . . . . in the last analysis, the student must depend not upon the picturing power of the mind, but upon his knowledge of the fundamental principles and his power to reason." We recognize that diligence, persistency, close observance of fundamental principles, and careful analysis come mighty close to offsetting a deficiency in structural aptitude.

My colleagues and I frequently embattle each other over the apparent inability of cadets to apply the things they learn in one Department to the problems presented in another. I may be dismayed at the inability of students who have mastered the calculus to apply some simple plane trigonometry in solving latitude and departure problems. The Mechanics people may not understand why a cadet does not easily solve graphically a problem in the resolution of forces after he has had descriptive geometry two years previously. Maybe our factory is unique in these phenomena, but I really expect such discouraging incidents actually occur in your shops too.

Well, it is mostly the fault of the teachers. The customers are for the most part blameless. Advanced applications and correlation, or the knitting together of principles or facts previously learned, are the responsibilities of the Department seeking to apply these in its instruction. The development of technical vocabulary is essential to effective correlation. I declare that graphical applications in Mechanics cannot be taught without teaching mechanics. The Graphics Department can give instruction in the drawing of parallelepipeds and their diagonals in space. The fact that these can represent forces acting upon a body is an expedient probably hit upon by some forgotten physicists, so we think it best to let the physicists present the idea to the students.

We try to face the problem of inter-departmental applications with tolerance and patience. It is not surprising that teachers of advanced subjects must wade gradually in the depths of applying fundamental facts and principles to their specific affairs, rather than diving off the deep end assuming that all knowledge previous pumped into the student is on the top layer of his recollections, and that applications are obvious. Without evading our responsibility for embedding the fundamentals of our subjects as firmly as possible in the students in our charge, we insist that the application and correlation of these in advanced fields is the responsibility of each

succeeding echelon in the educational structure.

We've had some fun lately by requiring cadets to bring their texts in solid mensuration to class and giving them some of the practical problems they've had in the Math Department to solve by descriptive geometry methods. We've done the same with solid trigonometry. The scheme is invariably an eye opener and the cadet discovers for himself some of the practical advantages of describing far more forcefully than otherwise. That is some of the flux that flows through this pipe that connects with the Math Department.

The matters of motivation and incentive are active problems for us. Last week a text book salesman called. In discussing his catalog I queried him as to his titles on Education and Education Psychology. He was amazed that I referred to such a subject. He declared that it had been his observation in visiting many colleges and universities that the popular opinion among many educators is that West Point closes its eyes to such matters, giving little or no thought to teaching methods, and that motivation and incentive consisted figuratively of the flat of a bayonet smartly applied to the seat of the breeches. On the contrary, despite the undeniable effectiveness of such motivation, West Point does pay great attention to the sensible aspects of the matter. Constant search is made for improved and more scientific methods of teaching and inspiring the desire to learn. Actually it may seem to you that motivation at West Point should be easy. Obviously our students point to a single goal - to become Army and Air Force officers - but this is actually as broad a goal as that of any college of engineering which is concerned with the fundamental education for civil, mechanical, electrical, architectural, chemical engineers, etc. The Army and the Air Force actually contain the counterparts for each of these specialties and besides must develop people for the combat arms - infantry men, artillery men, tankers, etc.

Despite our care in demonstrating to the cadets the wide-spread use of mechanical equipment throughout the Army and the consequent need for knowing the graphical language of engineering, some of the lads who are pointing particularly for the combat arms are inclined to take the attitude reflected in Kipling's poem entitled "Arithmetic on the Frontier";

"No proposition Euclid wrote,  
No formulæ the text books know,  
Will turn the bullet from your coat,  
Or ward the tulwar's downward blow.  
Strike hard who cares - shoot straight who can  
The odds are on the cheaper man."

In contemplating a successful future for themselves, cadets realize that Eisenhower used descriptive geometry very little in his career. But, we know that General MacArthur engaged in the usual military engineer pursuits in his earlier days. And, at the other extreme, there is no doubt in anyone's mind about the employment of the graphic language by the engineers and Ordnance people in the current military program. So, we must promote our motivation for the purely Engineering Drawing part of our work on a broad basis - it must be constantly worked at by the instructors. We never know just what professional direction any one cadet will take. We can never be sure that the fire is burning brightly enough to inspire cadets to their fullest endeavors. So many fall by the wayside - not necessarily because of incapacity, but for the lack of academic spark, the lack of determination to conquer, proper motivation, if you please. Therefore, motivation is a never-finished activity. Throughout our courses instructors must drive into every chance opening a wedge of motivation. It is their duty - perhaps it is their most important duty, because until the fire is lighted within the cadet, the instructor's efforts are of minor effect. After the fire is ignited, the instructor himself is less essential. If the individual desperately wants to learn, he will learn possibly in spite of the instructor.

We believe these things and strive to make them active forces in our department. The instructor is the vital factor. If he is inspiring, he is successful. Of course, if the desire to learn is already a burning passion in some cadets when they come to us, they need little stimulus in this direction from the instructors, but until that fire is burning brightly, whether it be spontaneous or ignited by an inspirational teacher, no results worth anything will accrue. Possibly, in some, the only active stimulus is the fear of a deficient average. Put the necessary ingredients in the finest blast furnace in the world - nothing happens without the fire. There is no steam without fire, and if there is no steam we are wasting our time. On my chart the fire is not shown, but the chart is incomplete without it. The fund of knowledge available is more than adequate - that's in the textbooks and is supported by teaching aids, the instructor's background is sufficient, and the sequence of presentation is well designed - but if there is no inspiration, no desire to learn, no effort on the part of

the cadet, the knowledge pumped into the system, and the idle performance of exercises, produce nothing but a sticky mass which clogs the pipes.

A splendid essay on this matter was written by W. B. Wiegand of the Columbus Carbon Company. It appeared in the last issue of the "Journal of Engineering Education." Mr. Wiegand says: "Right attitudes are not fostered by this or that subject of study . . . a teacher cannot give an adequate training in anything unless he knows and can make his pupils see what is great in it." The mechanics of conducting a course of instruction are comparatively simple. It is easy to strike the attitude of "Well, we dished it out - let those who want it lap it up. We'll discharge those who are not interested in our offerings." But, this is an entirely negative instructor attitude not tolerated in any school that I know of at the present day. It presumes that the student attitudes prevailing at the moment are fixed and unalterable.

The material charged to our care is too valuable to be treated so casually. To avoid having sludge in the pipes of our furnace, there must be a constant endeavor to keep the fire hot. To be exposed to a hot fire is not necessarily a relaxing, pleasant experience. The atmosphere around an effective teacher is not always comfortable. It may be too hot for comfort - a scorching, blistering, searing experience which will never be forgotten. The inspirational challenge does not lead to a life of ease. Steel cannot be made in a kitchen stove. Men do not win the Medal of Honor by merely following precisely the accepted rules of military technique.

This concludes my remarks. I've tried to expand the subject of Military Graphics by giving you a resume of how Engineering Drawing is handled at West Point. I have made practically no reference to specific problems or to classroom procedures, confining myself to the major aspects of the program - objectives - course components - motivation. However, if any are interested in the more minute details, I'll be very glad to discuss them after this session.

# FUNDAMENTALS OF ENGINEERING DRAWING, Revised

By WARREN J. LUZADDER, PURDUE UNIVERSITY

The basic principles of engineering drawing are here presented in such a way that the beginning student can find satisfying answers for all of his ordinary questions. Written in simple, understandable language, the major portion of the text leads up to the preparation of machine drawings. The methods used in such preparation are the same as those in other fields of engineering. Thus the student is given a good foundation for later study in some specialized field such as structural drawing. This revised edition includes many improved illustrations.

Published 1946 • 623 Pages • 6" x 9"

## PROBLEMS IN ENGINEERING DRAWING, Revised

By WARREN J. LUZADDER, J. N. ARNOLD, M. H. BOLDS, PURDUE UNIVERSITY; and  
F. H. THOMPSON, UNIVERSITY OF CALIFORNIA (BERKELEY)

Appropriate to the usual elementary course in engineering drawing, the 69 problems in this workbook can be used with Luzadder's FUNDAMENTALS OF ENGINEERING DRAWING, Revised, or any standard text. They cover all phases of the subject.

Published 1946 • 69 worksheets • 8½" x 11"

## DESCRIPTIVE GEOMETRY

By EARLE F. WATTS, AND JOHN T. RULE, MASSACHUSETTS INSTITUTE OF TECHNOLOGY

Covering the basic material of elementary graphical theory applicable to engineering problems, this text develops the ability of the student to solve such problems by the simplest graphical methods. It does not limit the student to one method of attack in solving problems. All methods are thoroughly described, enabling the student to choose the simplest solution to each problem.

Published 1946 • 301 Pages • 6" x 9"

## PROBLEMS IN DESCRIPTIVE GEOMETRY

By EARLE F. WATTS AND ARTHUR L. GOODRICH, MASSACHUSETTS INSTITUTE OF TECHNOLOGY

These problems have been selected to illustrate the fundamentals of descriptive geometry, the special methods which branch out from those principles, and the application of those methods to the graphical solution of engineering problems. They are designed to correlate with Watts and Rule's DESCRIPTIVE GEOMETRY.

Published 1946 • 64 plates • 8½" x 11"

*Send for your Copies Today!*

**PRENTICE-HALL, Inc.**

70 FIFTH AVENUE

NEW YORK 11, N. Y.

(Continued from page 9)

This picture of the variability and inadequacy existing in high school drawing courses can point to only one method of evaluating the quality of preparation of any high school applicant for college credit. That is the comprehensive placement examination. As a matter of fact, of the 16 schools who reported that they did consider high school drawing for credit, 14 required the passing of an examination before permitting omission of elementary drawing. This examination, however, should not be open to all. Definite pre-exam requirements should be set up. Seven out of the 14 colleges requiring this examination, required approval of the department before granting permission to take the exam.

This examination should be comprehensive in the strictest sense of the word - it should cover all the subjects included in the college course, even though it makes a 3 or 4 hour exam. I know of one college in which an even longer exam is given for this purpose. And a mere passing grade should not be sufficient to warrant exemption. On an A, B, C, D, Fail basis a high C or a B should be necessary to pass. One college states "Students who have been given college credit for first quarter drawing by barely passing our examination are seriously handicapped in second and third quarter work."

Our division is at present preparing an examination for this purpose, and we have hopes that it will soon be ready for use.

And now, what recognition should be given by the college to those who are sufficiently prepared in high school to pass the examination? The colleges provide only two methods by which to take care of those who qualify for advanced standing. They are:

1. To permit (or require) the omission of courses which the applicant has qualified in - but requiring the omitted credit hours to be made up by taking other subjects.
2. To grant outright credit toward college graduation in the amount of the number of credit hours in which the applicant has qualified.

These two methods apply to all students, whether they are entering freshmen or upper class transfers. One of these methods, then, must be applied to students entering with advanced standing in drawing.

It is my contention that college credit toward graduation should only be given for work done in college, and at the college level. Engineering drawing at the college level is distinctly different from high school drawing, as I have indicated at the beginning of this paper. The tempo of the work is greatly increased; principles are considered in their fundamental aspects, and their application to concrete problems is stressed; the material of the course is presented at the mature level of the adult, and the student must rise to this level of maturity in order to understand the work.

College work represents a growth and development

of the student toward an educated maturity, a much faster and more significant growth than high school work can hope to attain. So while we may excuse the entering freshman from rehashing material which he has already learned well, we certainly should not extend college credit when that learning has been acquired at lower than college level. By doing so we defeat the purpose of college work, and actually tend to pull it down to the level of the secondary school.

Therefore when advanced standing has been granted in elementary drawing, the student should be required to substitute credit hours in other work for it. Of those 16 colleges that do accept high school drawing, 8 require such a substitution of credits, 5 give credit toward graduation, while 3 did not specify.

This method of providing for advanced standing is not new to college experience. It has been used for a number of years in the Language, Mathematics, and English departments. It can be, and has been used in giving advanced standing in drawing in at least 8 colleges, as the preceding figures indicate.

And now, just a few comments concerning the questionnaire and some of the data which I have not yet given you. Forty questionnaires were sent out to a cross-section of the engineering colleges over the whole country, in approximate proportion to the college population of the various sections. Thirty-seven replies were received, a few of them incomplete.

In literal reply to question #1 there were 29 who answered "No" and 7 who answered "Yes". If, however, I rephrase the question to "Do you provide some means of permitting students with high school drawing only to qualify for advanced standing in college drawing" it will give more nearly the information we want. By studying the answers to the questions following #1, I determined the response that would have been made to this rephrased question and found that 21 provide no means for obtaining advanced standing, and 16 do provide some means. This is the tabulation shown in the summary.

The tabulations for questions #2 and #3 include only those who answered "Yes" to revised question #1. There were 3 blanks under #2. Under #3 there were a few cases in which a college stipulated two conditions for granting credit, and so the totals do not add up to 16. Two answers to question #3 from colleges in the "No" column indicated that they would grant credit under special circumstances, by means of examination, or #3a. These are not included in the tabulation.

The estimates given under #4a were in most cases an approximation only, and in several cases were omitted entirely, and so cannot be considered too reliable. I can say, however, that the estimate for the Mid-west section, 31%, agrees with what we would have made for Wisconsin. The extremely high estimate for the West Coast was occasioned by the fact that one of the schools contacted there required one unit of high school drawing for entrance.

(Continued on page 31)



TRADE MARK

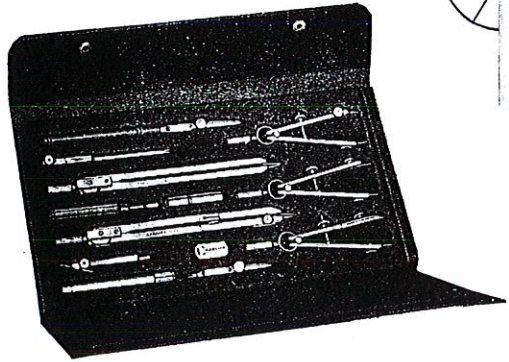

CHARVOZ SET No. 677

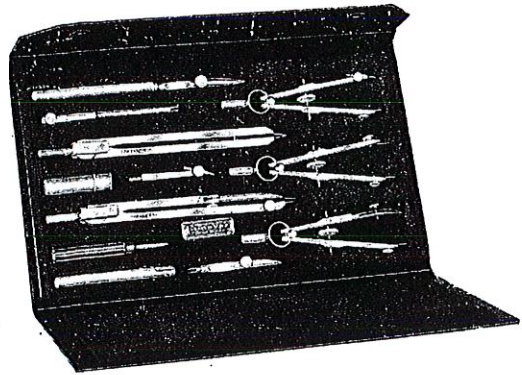

CHARVOZ SET No. 777

A complete attractively priced line of  
College and Professional Drawing Sets

by

**CHARVOZ**

World Famous Manufacturer  
of

Precision Drawing Instruments

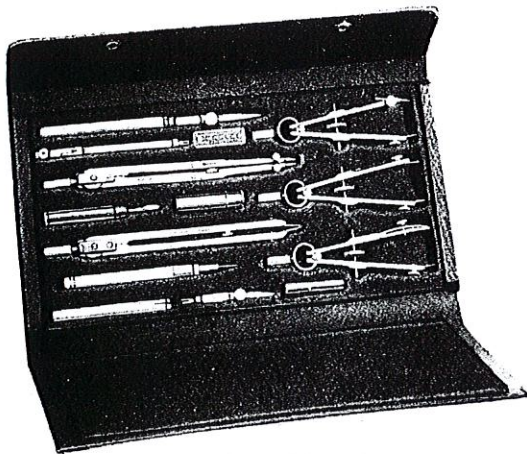

CHARVOZ SET No. 877P

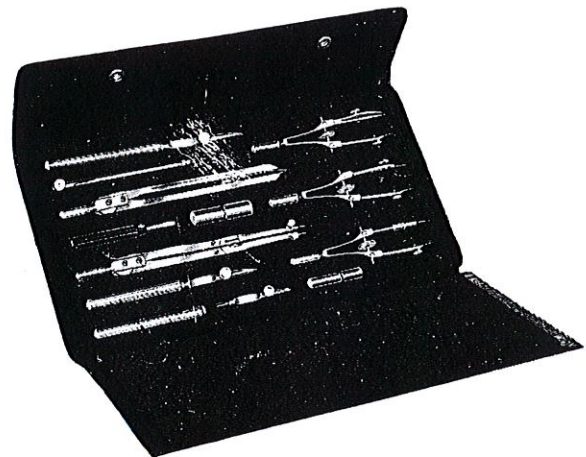

CHARVOZ SET No. 1277  
with stainless steel  
Swiss Bow Instruments

Write and ask for our new 1949 Catalog and Price List

**CHARVOZ-ROOS**  
**CORPORATION**

101 Fifth Avenue

New York 3, N. Y.

(Continued from page 29)

The answers to the second part of question #4 were extremely interesting and revealing. It is quite apparent that at present very few high school students consider themselves sufficiently prepared to ask for exemption in college drawing. Even for those 16 schools that do provide a means for qualifying for

advanced standing, only about 2% of their freshmen did apply for it. This would indicate that the general problem of college credit for high school drawing is not as pressing a question as many of us had supposed.

QUESTIONNAIRE

1. Do you ever accept high school drawing in lieu of your elementary drawing courses?
2. In accepting such drawing in lieu of your courses, do you-
  - (a) Give the student that equivalent credit toward graduation?
  - (b) Require the substitution of other courses (not necessarily drawing courses) to equal in credit value the omitted drawing courses?
3. Under what conditions do you (give credit toward college graduation) for high school drawing, or (accept it in place of your elementary drawing courses)? Strike out one.
  - (a) After passing an examination equivalent to a final in the course in which credit is desired?
  - (b) By certification that the applicant has passed \_\_\_ years of senior high school drawing?
  - (c) By certification that the applicant has passed \_\_\_ years of drawing at a senior high school that has an accredited (by your department or college) drawing course?
  - (d) By submission of satisfactory groups of drawings done in high school.
  - (e) Other.
4. Can you give an approximate estimate of-
  - (a) The percentage of entering freshmen who have had some drawing in senior high school?
  - (b) About how many of these apply for exemption in drawing on the basis of their high school work?
5. Do you care to add any other comments which might apply to this subject?

TABULATION OF REPLIES BY SECTIONS

| Section      | Total Replies | #1  |    | #2 (Yes only) |   | #3 (Yes only) |   |   |   |   | #4  |      |
|--------------|---------------|-----|----|---------------|---|---------------|---|---|---|---|-----|------|
|              |               | Yes | No | a             | b | a             | b | c | d | e | a   | b    |
| Northeast    | 6             | 2   | 4  | 1             | 1 | 1             | 1 |   | 1 |   | 48% | Few  |
| Mid-Atlantic | 7             | 4   | 3  | 0             | 3 | 4             |   |   | 1 |   | 38% | Few  |
| Southeast    | 4             | 1   | 3  | 0             | 1 |               |   | 1 |   |   | 18% | None |
| Southwest    | 3             | 0   | 3  | 0             | 0 |               |   |   |   |   | 20% | Few  |
| East Central | 7             | 4   | 3  | 2             | 0 | 3             | 1 |   |   |   | 42% | 9%   |
| Midwest      | 6             | 3   | 3  | 1             | 2 | 3             |   |   |   |   | 31% | 10%  |
| West         | 2             | 1   | 1  | 1             | 0 | 1             |   |   |   |   | 27% | None |
| West Coast   | 2             | 1   | 1  | 0             | 1 | 2             |   |   |   |   | 90% | None |
| Total        | 37            | 16  | 21 | 5             | 8 | 14            | 2 | 1 | 2 | 0 | 38% | Few  |

## REPORT OF THE BIBLIOGRAPHY COMMITTEE

by

Professor H. H. Fenwick  
University of LouisvilleNEW AND REVISED BOOKS

| Author  | Title  | Ed.    | Publisher   | Year | Pages                 | Price        |
|---|--|--------|---|------|-----------------------|--------------|
| American Geographical Society                       | Manual for the Classification and Cataloguing of Maps, etc.              |        | American Geographical Soc. (Broadway & 156th, N.Y.) |      | 43                    | \$1.00       |
| Cooper, C.D. & Machovina, P.E., Vierck, C.J.        | Engineering Drawing Problems   |        | McGraw-Hill   | '48  | 88<br>(plates)        | 3.50         |
| French & McCully                                    | Engineering Drawing Sheets, Series F                                     | 1      | McGraw-Hill   |      |                       | 4.00         |
| French & Svensen                                    | Mechanical Drawing   | 5th    | McGraw-Hill   | '48  |                       | 2.80         |
| Giesecke, Mitchell and Spencer                      | Technical Drawing  | 3rd    | MacMillan Co.                                       | '49  | 730                   | 4.50         |
| Hoelscher, Springer, & Pohle                        | Industrial Production Illustration                                       | 2nd    | McGraw-Hill   | '46  | 243                   | 4.50         |
| Hood, G.J.  | Geometry of Engineering Drawing  | 3rd    | McGraw-Hill   |      | 388                   | 3.00         |
| Katz-Hyman  | Aircraft Drafting<br>Technical Sketching and Visualization for Engineers | 1<br>1 | MacMillan<br>MacMillan Co.                          | '49  | 386<br>176            | 5.00<br>5.70 |
| Kenny & McGrail                                     | Architectural Drawing for the Building Trades                            | 1      | McGraw-Hill   | '48  |                       |              |
| Luzadder, W.J., Arnold, J.N., Bolds, Thompson, F.J. | Problems in Engineering Drawing  | Rev.   | Prentice-Hall                                       | '48  | 69<br>(plates)        |              |
| Orth, J.D. & Worsencroft, R.R., Doke, H.B.          | Basic Engineering Drawing<br>Problems in Basic Engineering Drawing       |        | Irwin-Farnham<br>Pub. Co.                           |      | 346<br>150<br>(prob.) | 3.50<br>2.50 |
| Russ, J.M.  | Quiz Questions to Accompany French's Engineering Drawing.-7th Ed.        | 1      | McGraw-Hill   | '48  | 54                    | .50          |
| Spencer & Grant                                     | Technical Drawing Problems (Series II)                                   | 1      | MacMillan   | '48  | 138                   | 4.25         |
| Street, W.E.  | Technical Descriptive Geometry   | 1      | D. Van Nostrand                                     | '48  | 179                   | 2.75         |
| Street, W.E., Perryman, & McGuire                   | Technical Descriptive Geometry Problems                                  | 1      | D. Van Nostrand                                     | '48  |                       | 2.50         |
| Turner, W.W.  | Freehand Sketching for Engineers   | 1      | Ronald Press  | '48  | 97<br>sheets          | 2.50         |
| Warner, F.M.  | Applied Descriptive Geometry<br>(with drafting room problems)            | 3      | McGraw-Hill   |      | 252                   | 2.75         |
| Warner & Douglas                                    | Applied Descriptive Geometry Problem Book                                | 1      | McGraw-Hill   | '48  |                       | 2.50         |
| Watts, E.F. & Goodrich, A.L.                        | Problems in Descriptive Geometry   |        | Prentice-Hall                                       |      | 64<br>(plates)        |              |
| Wellman   | Technical Descriptive Geometry   | 1      | McGraw-Hill   | '48  | 508                   | 4.00         |

MAGAZINE ARTICLES

| Author                    | Title  | Publisher                      | Vol.       | Page            | Month              | Year       |
|---------------------------|--|--------------------------------|------------|-----------------|--------------------|------------|
| Bennett, R.B.             | Chart reading & drafting speeded by proportional interval divider (Diag.)        | Chem. Eng.                     | 54         | 138             | Dec.,              | '47        |
|                           | Better light in drafting room and main office (Ill.)                             | Factory Management             | 106        | 98-9            | April,             | '48        |
| Bishop, M.C.              | Boomerang in grading engineering drawing problems                                | J. of Eng. Educ.               | 38         | 768-70          | June,              | '48        |
| Bond, W.L.                | Simple procedure for the making of alignment charts. (Diag.)                     | J. of Ap. Phys.                | 19         | 83-6            | Jan.,              | '48        |
| Bower, C.T.               | Pantograph Leg<br>Linkage adapts special compass for blueprinting                | Am. Mach.                      | 92         | 127             | Nov. 18,           | '48        |
| Candee, A.H.              | Formulas for involute curve layouts  | Product Eng.                   | 19         | 145             | Aug.,              | '48        |
| Cleet, E. Van             | What is a map?   | Science                        | 108        | 521-2           | Nov.,              | '48        |
|                           | Construction of alignment nomogram from empirical data. Lo-Ho (Diags.)           | Franklin Inst.                 | 245        | 227-44          | Mar.,              | '48        |
|                           | Daylight movies, reflecting movies & screen for schools                          | Elect. West.                   | 99         | 78              | Nov.,              | '47        |
|                           | Draughting machines for isometric projection (Ill.) Diags.                       | Engineer<br>Engineering        | 185<br>165 | 518-19<br>536-7 | May 28,<br>June 4, | '48<br>'48 |
| Elrod, S.B.               | Modern dimensioning practice Diags.  | Product Eng.                   | 19         | 123-5           | Oct.,              | '48        |
|                           | Folding stereoscope (Ill.)   | R. Sci. Instr.                 | 19         | 729-30          | Oct.,              | '48        |
| Goodwin, J.B.             | Angle trisected by graphical methods discussion                                  | Civil Engr.                    | 18         | 27-8<br>173-3   | Jan.,<br>Mar.,     | '48<br>'48 |
| Grushky, M.               | Hints on Effective Use of Reproductions  | Eng. N.                        | 141        | 88-90           | Aug.,              | '48        |
|                           | Improved method of reproducing engineering drawings (Ill.)                       | Mach.                          | 55         | 169-70          | Dec.,              | '48        |
| Lasken, H.                | Direct determination of compass settings for proportionate area pie charts       | Am. Stat. Assn. J.             | 43         | 94-5            | Mar.,              | '48        |
| Midgette, E.L. and Others | Characteristics of a good designer; abstract                                     | Mach. Design                   | 201        | 170             | Oct.,              | '48        |
| Parrett, R.E.             | Preparation of layouts aided by photostating (Ill. plans)                        | Factory Management             | 106        | 70-1            | Nov.,              | '48        |
|                           | Perspective drawings device for producing modified isometric projections. (Ill.) | Automobile Eng.<br>Engineering | 38<br>105  | 234-6<br>536-7  | June,<br>June,     | '48<br>'48 |



*Thoroughly tested, widely used*

## **BASIC ENGINEERING DRAWING**

By H. D. ORTH, R. R. WORSENCROFT, and H. B. DOKE, all of University of Wisconsin

**T**HIS text covers thoroughly and in some considerable detail only that essential information regarding the theory and practice of drawing which must be a part of the basic education of every engineering student. The material is presented in such a form that both theory and manual skills are correctly, clearly and definitely explained.

The many schools using BASIC ENGINEERING DRAWING in the first year of its publication have found that its emphasis on essentials and omission of innumerable special techniques of reference value only, have produced a book of exceptional clarity for student study.

### **Table of Contents:**

Instruments and Materials. Orthographic Representation. Sectional Views. Engineering Lettering. Technical Sketching. Mechanical Drawing. Tracing in Ink. Geometrical Constructions. Shop Processes. Principles of Dimensioning. Screw Threads

and Springs. Keys, Pins, Rivets, and Welds. Machine Elements. Conventional Representation. Working Drawings. Pictorial Representation. Intersections and Developments. Graphs and Charts.

346 pages, \$3.50

### **PROBLEMS IN BASIC ENGINEERING DRAWING**

Also by H. D. ORTH, R. R. WORSENCROFT, and H. B. DOKE. This problem book has been prepared for use with the BASIC ENGINEERING DRAWING text and consists of approximately 150 problems on eight and one-half by eleven tear-out sheets which, through saving of time in the initial location and layout of the work, enable the student to obtain a maximum amount of drawing practice and experience. \$2.50

*Texts by* William Wirt Turner, University of Notre Dame

### **SIMPLIFIED PERSPECTIVE**

**T**EXT on the theory and practice of perspective drawing. Treatment equips the user to make architectural, mechanical, and production drawings such as the exploded views finding increasing use in manufacturing. Construction procedures are given on each drawing. Teacher's Manual available. 243 pages, \$5.00

### **FREEHAND SKETCHING FOR ENGINEERS**

**D**EVELOPS sketching ability of students and engineers, teaches theory underlying engineering drawing, and trains in the reading of drawings. The course may be taken without any prerequisite course in drawing. Based on the latest revised American Standard practices. 97 sheets, packaged in envelopes. Teacher's Manual available. \$2.50

**THE RONALD PRESS COMPANY, 15 East 26th Street, New York 10**

# DEPARTMENTS OF ENGINEERING DRAWING . . .

*Solicit your members for subscriptions for the*  
**JOURNAL OF ENGINEERING DRAWING.**

*This is your publication.*



Send subscriptions to:

Ralph T. Northrup, Circulation Manager  
JOURNAL OF ENGINEERING DRAWING  
% Department of Engineering Drawing  
Wayne University  
Detroit 1, Michigan

(Continued from page 22)

(6) Observing the extent of visible area A, and its alignment directly above line 7-9 in the front view, we conclude that area A is the top horizontal surface of the object. Line 10-12 is the only line in the front view that lies directly below area B, hence we conclude that area B is a horizontal surface at mid-height on the front portion of the object.

(7) Comparing the alignment of the top and front views it is apparent that area D matches only line 5-6, area C matches only 3-4, and area E matches only line 2-6. The position of these three vertical surfaces on the object is thus definitely established.

(8) Turning again to the side view, it becomes apparent that all of the above conclusions are confirmed. Area F is obviously the side view of area E; horizontal surfaces A and B appear as lines 16-17 and 18-19, respectively; vertical surfaces C and D appear as lines 16-19 and 18-20, respectively.

By the above reasoning process the shape and position of the five visible surfaces of the object have been definitely established. By similar reasoning the shape of the three remaining hidden surfaces (the back, bottom, and left-end) can be determined. The object can now be visualized as a solid bounded by eight plane surfaces, the

exact shape and location of each surface being known. The correctness of the analysis cannot be challenged, because each conclusion is based upon solid facts and principles.

What is new or different in the material that has been presented here? As far as principles are concerned, very little. The rule of contiguous areas and the rule of configuration only express in concise form what every teacher of drawing already knows. It is the orderly and methodical application of these principles that they take on a new significance. The teacher who will explain the reading of a drawing by a strict adherence to facts and logic can give a convincing demonstration to his students. He can show them that no step in the process requires a special ability that they do not possess, and that a vivid imagination is not a prerequisite to accurate observation and logical reasoning. From a psychological standpoint the battle is half won, for the student acquires a new confidence in his own powers of analysis. He no longer stares at the flat, two-dimensional figures waiting for a flash of inspiration; there is real concrete thinking to be done, and he knows how and where to begin. He has a definite plan of action that he knows will produce results. And with it all, he has also acquired a new respect for the logical science of engineering drawing.

(Continued from page 32)

MAGAZINE ARTICLES--Continued

| Author                        | Title  | Publisher    | Vol. | Page   | Month    | Year |
|-------------------------------|--|--------------|------|--------|----------|------|
|                               | Plant layout templates of acrylic, serve as negatives in blue-printing arrangement   | Sci. Am.     | 177  | 271    | Dec.,    | '47  |
|                               | Plastic viewer redesigned without die cavity change (stereoscope) (Ill.) Diags.  | Product Eng. | 19   | 103    | Apr.,    | '48  |
| Schooley, A.H.                | Simple stereoscope for viewing double lens camera stereographs without transposition (Diag.)   | Science      | 107  | 281    | Mar. 12, | '48  |
| Simmons, R.H.                 | Development in the graphic arts  | Paper Tr. J. | 127  | 142-53 | Nov. 18, | '48  |
| Strasser, F.                  | Button holders solve impossible layout problems (Diags.)   | Am. Mach.    | 92   | 103    | Jan. 1,  | '48  |
| Taylor, N.W.                  | Simplified dimensioning system on cartesian co-ordinates has many advantages as used in machine layouts  | Mach. Design | 2-   | 135-7  | Feb.,    | '48  |
| Things not to do in drafting. | Recommendations for solving common problems prepared for solving common problems prepared for inclusion in S.A.E. Aeronautical drafting manual | S.A.E.-J.    | 56   | 35-8   | Jan. 10, | '48  |
| Wright, F.L.                  | A portfolio of work (Ill. plans and Diags.)  | Arch Forum   | 88   | 65-165 | Jan.,    | '48  |

**Text-Films**  
**on Engineering Drawing**  
**Bring RESULTS . . . . .**  
**Like These . . . . .**

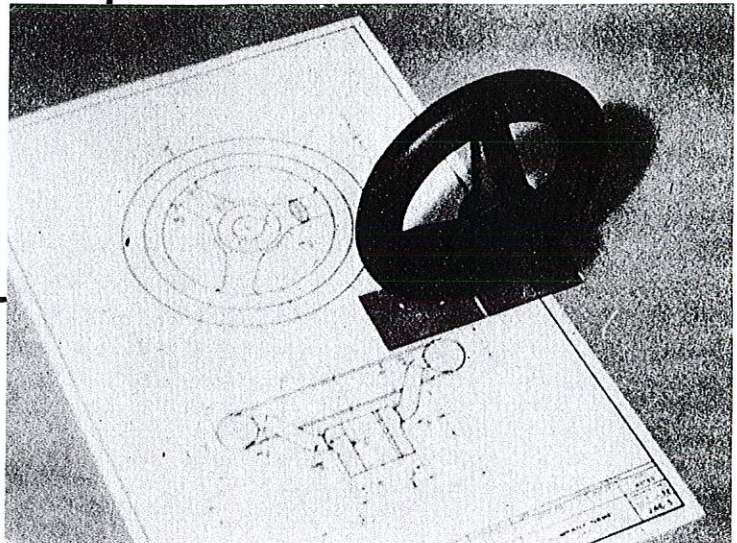

**T**HESE seven sound motion pictures and six silent filmstrips, correlated with French's *Engineering Drawing*, have been in actual classroom use for over a year. In that time, their value to instructor and student has been convincingly demonstrated. The Engineering Drawing Text-Film Series performs a twofold function:

1. In providing the instructor with expert three-dimensional drawings and photographs which save him hours of time usually consumed in blackboard demonstration, more of his classroom time can be devoted to the supervision of *actual drawing practice*.
2. In clear, step-by-step development, the more difficult theories of Engineering Drawing are built up on the screen (and later reviewed in the filmstrips), thus assuring the student a clearer comprehension; in the same manner, actual drawings are created on the screen, providing the student with expert demonstration of accepted drawing techniques.

These films and follow-up filmstrips can perform the same functions in your classroom—increasing the effectiveness of your presentation through a competently visualized treatment of basic Engineering Drawing principles and practices.

**MOTION PICTURE TITLES OF THE  
ENGINEERING DRAWING SERIES**

1. According to Plan—  
Introduction to Engineering Drawing
2. Orthographic Projection
3. Auxiliary Views—Single Auxiliaries
4. Auxiliary Views—Double Auxiliaries
5. Sections and Conventions
6. The Drawings and the Shop
7. Selection of Dimensions

*Fill out attached coupon for further information on this series of Text-Films*



**McGraw-Hill Book Co., Inc.**  
**TEXT-FILM DEPARTMENT**  
**330 WEST 42nd STREET**  
**NEW YORK 18, N. Y.**

Please send Folder MA on Text-Films on Engineering Drawing.

Name .....

Title .....

Address .....