

JOURNAL OF ENGINEERING DRAWING

VOL. 15, NO. 1

FEBRUARY, 1951

SERIES NO. 43



PUBLISHED
BY
THE
DIVISION
OF
ENGINEERING
DRAWING
AND
DESCRIPTIVE
GEOMETRY
A S E E

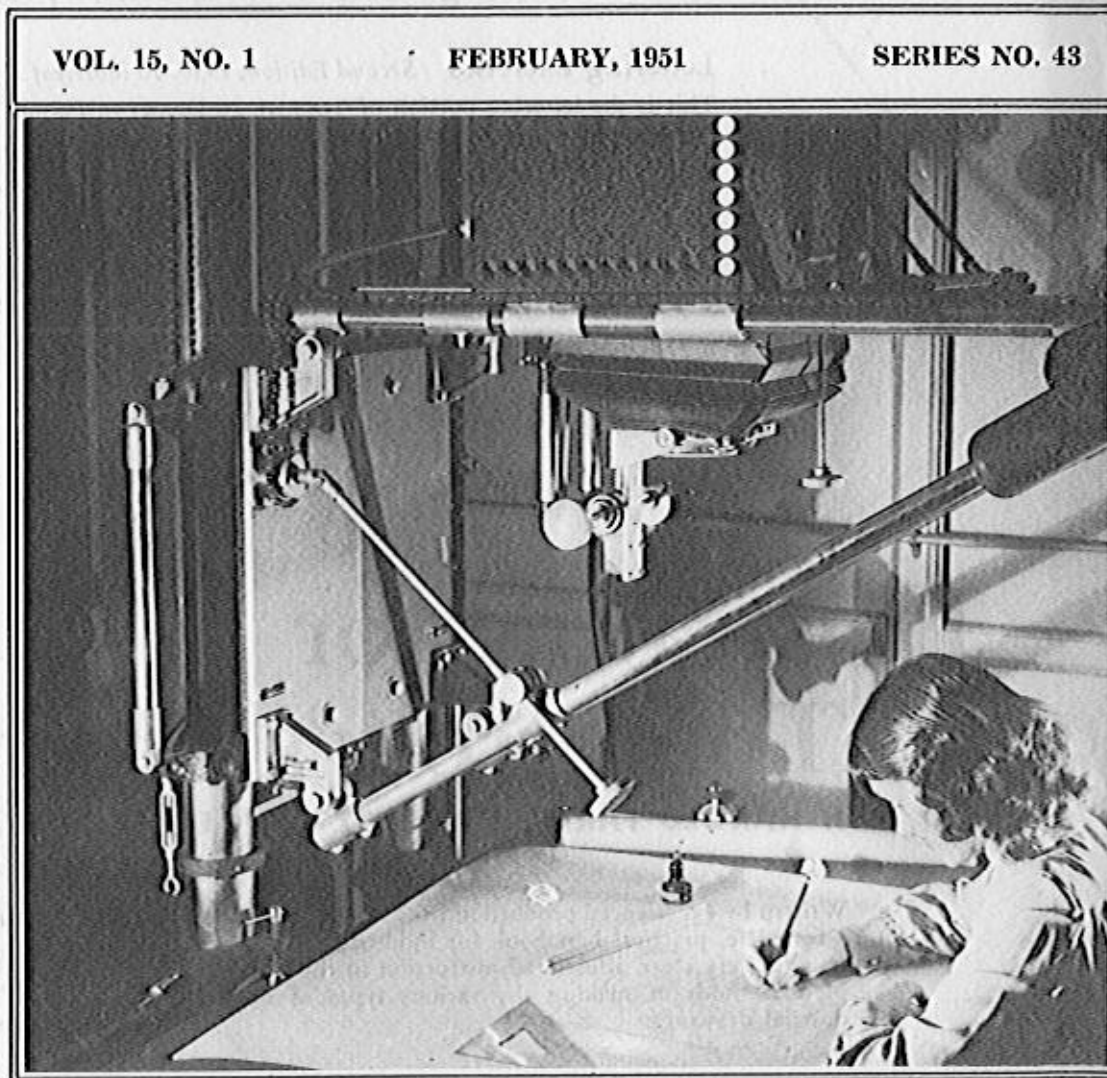

Enlarging a drawing on a Saltzman Overhead Projector

College of Applied Science
Syracuse University
Syracuse, N. Y.

For Engineering Drawing Students

Technical Drawing

F. E. GIESECKE, A. MITCHELL & H. C. SPENCER

Third Edition, 1949. 833 pages. 1001 illus. \$4.50

Outstanding in its field, this book includes easy-to-understand explanations of all basic techniques, excellent illustrations, and many practical problems. Important features of the new edition are the expanded chapter on shop practices; the simple, easy-to-learn teaching of perspective drawing; the complete treatment of dimensioning; the article on the Eckhart method of intersections, and the chapter on aeronautical drafting.

Technical Drawing Problems *Second Edition, 1947. 93 sheets. \$3.50*

Lettering Exercises *Second Edition, 1950. 16 looseleaf sheets. \$1.00*

This is the lettering portion of **TECHNICAL DRAWING PROBLEMS**

Technical Drawing Problems. Series 2 *By Spencer and Grant. 1948. 138 sheets. \$4.25*

Technical Lettering Practice *1949. 13 sheets. \$1.35*

This is the lettering portion of **TECHNICAL DRAWING PROBLEMS. SERIES 2**

Illustrating for Tomorrow's Production

J. HAROLD FARMER, ABBOTT J. HOECKER & FRANCIS F. VAVRIN

1950. 203 pages. 163 illus., 45 in two colors. \$5.00

Written by experienced production illustrators, this is a complete, practical handbook for industrial artists. It gives very clear, illustrated instruction in the simplest methods of making the various types of industrial drawings.

It describes in detail all steps in the preparation of drawings for reproduction and gives useful information on the reproduction processes, themselves, and includes special chapters on aircraft illustrating.

THE MACMILLAN COMPANY

60 FIFTH AVENUE

NEW YORK, N. Y.

JOURNAL OF ENGINEERING DRAWING

PUBLISHED IN THE INTEREST OF TEACHERS OF ENGINEERING DRAWING
AND RELATED SUBJECTS

VOL. 15, NO. 1

FEBRUARY, 1951

SERIES NO. 43

CONTENTS

FRONTISPIECE	Page 4
DIVISION ACTIVITIES by Professor Ralph S. Paffenbarger, Chairman, Division of Engineering Drawing, The Ohio State University	Page 5
DESCRIPTIVE GEOMETRY AND OPTICAL EFFECTS by Professor C. E. Rowe, University of Texas	Page 7
A COURSE FOR THE TRAINING OF ENGINEERING DRAWING TEACHERS by Professor Harold P. Skamser, Michigan State College.	Page 10
A SURVEY OF SUPERVISED CLASS HOURS REQUIRED IN GRAPHICS COURSES by Professor T. C. Brown, North Carolina State College.	Page 13
STANDARDS AS A TOOL FOR THE ENGINEERING GRADUATE by T. W. Ragan, Western Electric Company.	Page 20
THE TWO LANGUAGES OF THE ENGINEER by Professor H. C. T. Eggers, University of Minnesota.	Page 26
COMMENTS AND NEWS ITEMS.	Page 30

Annual Subscription Price, \$1.25

PUBLISHED IN FEBRUARY, MAY, AND NOVEMBER BY
THE DIVISION OF ENGINEERING DRAWING AND DESCRIPTIVE GEOMETRY OF THE
AMERICAN SOCIETY FOR ENGINEERING EDUCATION

PUBLICATION COMMITTEE

T. T. Aakhus, Editor
University of Nebraska
LINCOLN, NEBRASKA

Charles J. Vierck, Advertising
The Ohio State University
COLUMBUS, OHIO

Warren J. Luzadder, Cir. & Treas.
Purdue University
WEST LAFAYETTE, INDIANA

Robert H. Hammond, Ass't Cir. Mgr.
Purdue University
WEST LAFAYETTE, INDIANA

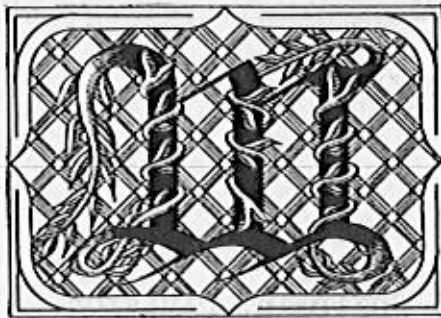

Wisdom
is the
principal thing;
therefore get
wisdom: and
with all thy
getting get
understanding.

Proverbs

Ernest R. Weidhaas '20

DIVISION ACTIVITIES

by

Professor Ralph S. Paffenbarger, Chairman
Division of Engineering Drawing
The Ohio State University

By the time this publication reaches you our mid-winter meeting will have been held and preliminary plans for our Summer School program at Michigan State College in East Lansing will have been considered.

First, I want to extend sincere thanks to Professor William E. Street, Chairman of the Committee, and to members of his staff of the Department of Engineering Drawing at Texas A and M College for the fine work they have done in arranging our program and all details for our mid-winter meeting. To those of you who are fortunate enough to be able to attend, I am certain that you will enjoy not only a fine program but unexcelled hospitality and housing in the finest quarters we have ever had the privilege of occupying during one of our meetings.

Next, I should like to list the officers and committees of the Division together with their duties and the progress of their activities.

OFFICERS

Chairman: Ralph S. Paffenbarger, The Ohio State University, Columbus, Ohio.

Secretary-Treasurer: Clifford H. Springer, University of Illinois, Urbana, Illinois.

Executive Committee: James S. Rising (1 yr.), Syracuse University, East Syracuse, New York.
John G. McGuire (2 yrs.), Texas A and M College, College Station, Texas.
William E. Street (3 yrs.), Texas A and M College, College Station, Texas.
Charles E. Rowe (4 yrs.), University of Texas, Austin, Texas.
Hiram E. Grant (5 yrs.), Washington University, St. Louis, Missouri.
Orrin W. Potter (1 yr.), Past Chairman of Division, University of Minnesota, Minneapolis, Minnesota.

Publication Committee - Journal of Engineering Drawing:

T. T. Aakhus, Editor, University of Nebraska, Lincoln, Nebraska.
Charles J. Vierck, Advertising Manager, The Ohio State University, Columbus, Ohio.
Warren J. Lutzdler, Circulation Manager and Treasurer, Purdue University, West Lafayette, Indiana.
Robert H. Hammond, Assistant Circulation Manager, Purdue University, West Lafayette, Indiana.

The publication committee is responsible for publishing three issues of this Journal, and sit with the Executive Committee in administering the affairs of the Division.

Editor T-Square Page: Jasper Gerardi, University of Detroit, Michigan.

Prepares and edits copy of material for T-Square page allotted to the Division of Engineering Drawing in the Journal of Engineering Education. Serves also on the Executive Committee of the Division.

ASEE General

Council Members: H. C. Spencer, Illinois Institute of Technology, Chicago, Illinois.

Represents the Division in the General Council, which handles the affairs of the parent society and serves also on the Executive Committee of the Division.

Special Awards

Committee: Frank A. Heacock, Chairman, Princeton University, Princeton, New Jersey.
H. C. Spencer, Illinois Institute of Technology, Chicago, Illinois.
O. W. Potter, University of Minnesota, Minneapolis, Minnesota.

One of the duties of this Committee, which is composed of the three immediate past chairmen, is to name a member of the Division for special recognition for distinguished service to the Division and outstanding work in his field. This award is presented annually at our last Division dinner held in connection with the annual meeting of the society.

Advanced Graphics

Committee: Frank A. Heacock, Chairman, Princeton University, Princeton, New Jersey.
John T. Rule, Massachusetts Institute of Technology, Cambridge, Massachusetts.
J. N. Arnold, Purdue University, West Lafayette, Indiana.
J. B. McGuire, Texas A and M College, College Station, Texas.
A. S. Levens, University of California, Berkeley, California.
Clyde H. Kearns, Jr., The Ohio State University, Columbus, Ohio.

This is the third year for this Committee with some slight changes in personnel. They are doing a fine job in encouraging and securing the active cooperation of engineering drawing departments throughout the country in this fertile field. Under the able leadership of Frank Heacock, we can expect excellent progress. Incidentally, Professor Heacock has applied for sabbatical leave of absence in the Spring term 1952 for the purpose of travel, study and research in graphics.

Bibliography

Committee: H. H. Fenwick, Chairman, University of Louisville, Louisville, Kentucky.
H. E. Grant, Washington University, St. Louis, Missouri.
E. F. Tozer, Northeastern University, Boston, Massachusetts.

This Committee has prepared a listing of publications in the field of graphics, both domestic and foreign and should have a revised edition for us at our Summer School meeting.

Committee on Drawing Instruments and Materials:

- J. Howard Porsch, Chairman, Purdue University, West Lafayette, Indiana.
 J. Gerardi, University of Detroit, Detroit, Michigan.
 L. R. Schruben, University of Southern California, Los Angeles, California.
 R. O. Loving, Illinois Institute of Technology, Chicago, Illinois.
 J. M. Russ, State University of Iowa, Iowa City, Iowa.
 E. M. Griswold, The Cooper Union, New York, New York.
 N. C. McGuire, University of Texas, Austin, Texas.
 H. G. Kinner, Rensselaer Polytechnic Institute, Troy, New York.

This Committee is continuing their study that they started last year because of the changing conditions dealing with uncertainties of supply, quality of material, costs and manufacturing difficulties in meeting specifications. This Committee will survey the field again and give us an additional report. They are concentrating primarily on drawing sets (case instruments) but it is hoped that they may find time to make investigations of some of the other materials as well.

Teaching Aids

Committee:

- H. B. Howe, Chairman, Rensselaer Polytechnic Institute, Troy, New York.
 F. M. Warner, University of Washington, Seattle, Washington.
 L. G. Palmer, University of Minnesota, Minneapolis, Minnesota.
 J. B. McGuire, Texas A and M College, College Station, Texas.
 H. L. Winkler, Illinois Institute of Technology, Chicago, Illinois.

This Committee will report on recent developments in this field dealing with movies, film strip, models, charts, etc. They will also be in charge of the exhibit of Teaching Aids to be shown in connection with our Summer School.

Policy

Committee:

- F. J. Higbee, Chairman, State University of Iowa, Iowa City, Iowa.
 Randolph P. Hoelscher, University of Illinois, Urbana, Illinois.
 Justus Rising, Purdue University, West Lafayette, Indiana.

The purpose of this Committee is to serve in an advisory capacity to the Division, and should receive all matters where experience and judgment warrant reference for an opinion. Their recommendations should receive attention at all times.

Election

Committee:

- Clifford H. Springer, Chairman, University of Illinois, Urbana, Illinois.
 Henry C. Thompson, Jr., Purdue University, West Lafayette, Indiana.
 Jean A. Anderson, Illinois Institute of Technology, Chicago, Illinois.

This Committee will prepare ballots for nominations and conduct election for nominees during the month of March. They will also prepare ballots and conduct the election of officers for the ensuing year. This election shall be completed by May 20, and the officers are announced at our business meeting luncheon held at the time of our annual meeting.

Any project that you may be interested in, falling within the jurisdiction of any of the aforementioned Committees should be referred to the committee chairman.

SUMMER SCHOOL FOR ENGINEERING
DRAWING TEACHERS - ANNUAL A.S.E.E. MEETING
MICHIGAN STATE COLLEGE
EAST LANSING, MICHIGAN
JUNE 21-29, 1951

In the November issue of the Journal, we published a rough draft of the proposed outline for our Summer School program. The entire program will be formulated at the Executive Committee meeting of the Division at College Station, Texas, on January 19, and will be published in full in the next issue of the Journal. Following our request in the November issue, as well as in response to some 200 letters of inquiry mailed to engineering school staff members throughout the United States and Canada, we have had numerous replies giving much helpful information and valuable suggestions for this program. It is certain that we will have an extremely interesting session and from all indications one that will be well attended. The general theme of this project will be "Improving Our Status as Teachers of Engineering Drawing."

The local committee selected to arrange the details for our meeting at East Lansing consists of the following:

- C. L. Brattain, Chairman
 O. W. Fairbanks
 N. R. Sedlander
 R. O. Ringoan
 (All of Michigan State).
 P. O. Potts, University of Michigan.
 J. Gerardi, University of Detroit.
 R. T. Northrup, Wayne University.

Three committees have been set up to arrange for various displays for our Summer School. The Committee selected to arrange for Display of Teaching Aids is the same as listed herein as the Division Committee on Teaching Aids. This Committee is headed by Harold B. Howe of Rensselaer Polytechnic Institute.

The Committee on Display of Student Work and Engineering Drawing Course Outlines consists of the following:

- J. Gerardi, Chairman, University of Detroit.
 James S. Rising, Syracuse University.
 Harold K. Skanser, Michigan State College.
 John G. McGuire, Texas A and M College.
 T. C. Brown, North Carolina State College.

The Committee on Display of Instruments and Drawing Materials consists of:

- Ralph T. Northrup, Chairman
 R. W. Grant,
 S. J. Friedman
 (All of Wayne University).
 J. Howard Porsch, Purdue University.
 One member from Michigan State.

(Continued on page 34)

DESCRIPTIVE GEOMETRY AND OPTICAL EFFECTS

by

Professor C. E. Rowe, The University of Texas

Presented at the Meeting of the Southwestern Section, American Society For Engineering Education, A & M College of Texas, April 8, 1950.

Several years ago the author conceived the idea of spinning a generating unit such as shown in Figs. 1 and 5, to generate surfaces of revolution. The spinning mechanism which was hand driven, has been equipped, recently, with an electric motor regulated to produce spinning speeds of 650 to 1100 rpm.

The operation of this device, or surface generator, has been highly interesting from the beginning, but recent experiments with old and new generating units have produced astonishing optical effects which can be checked or predicted on the drafting board.

It is physically impossible to generate a visible surface by the revolution of a line; therefore, a small rod, cord or wire is substituted for the line or generatrix in these experiments, and these will be called lines and considered as such.

Lines of Interference Produced During the Generation of Surfaces of Revolution.

If two or more rods are revolved simultaneously about the same axis to generate the same surface or different surfaces, a line or lines of interference also will be produced. These lines of interference may be mathematically related to the surface. For example, two opposite rods for the first and second generation of the hyperboloid of revolution will appear to generate the asymptotes of the hyperbolic outline, Figs. 1 and 2, but if opposite rods for the same generation are used the axis of the hyperboloid will be generated instead, Figs. 5 and 6.

The explanation of this optical phenomenon was rather elusive. Originally, two red rods as in Fig. 1, were revolved in front of a black background. This produced a reddish gray hyperboloid with black asymptotes. Then, white rods were revolved which produced a gray hyperboloid with the same black asymptotes. Following this, experiments were made with different colors of rods and various background colors, and it was found that the asymptotes were always a shade of the background color. Black rods revolved in front of a white background produced white asymptotes.

The explanation proposed by my colleague, Professor Lenhart, is supported by the optical effects observed during the experiments. A rod revolving about an axis generates a surface which has a certain shade of color. Two rods will generate a surface having a deeper shade of color. The object represented will appear to be twice as dense. This object is seen most clearly in front of a background plane of a contrasting color. If the projections of two rods coincide on the background as in Figs. 2 and 4, only the front rod is seen at that instant, and the observer sees the background as a line through the front half of the surface. We may say that the object is only one-half as dense at this instantaneous location of the rods, and the observer can see the background as a line through it. The author calls this optical effect a line of interference. The nearer rod interferes with or

obscures the view of the rod directly behind it. The line of interference actually appears to be on a frontal plane which passes through the axis of revolution. This location probably is an optical illusion.

A line of interference is produced also by the moving point which is the intersection of the projections onto the background of any two revolving rods. This explains why the spinning of the generating unit shown in Fig. 5 produces the axis shown in Fig. 6. It also explains why the unit shown in Fig. 7 generates the extra hyperbola shown in Fig. 8. Other examples of lines of interference resulting from the crossing of the projections of the rods are shown in Figs. 10 and 12.

An example of lines of interference resulting from both of the above methods is shown in Fig. 14. Here the axis results from the coincidence of the projections of the two halves of the ring. The "figure 8" is produced by the crossing of the projections of ring and rod.

In Fig. 15 a rod is used for the axis, and it prevents the formation of an interference axis as in Fig. 14.

The addition of one or two rods to almost any of the generating units shown may add many new lines of interference which may form a complicated but interesting pattern.

Further Experiments

Next, a series of experiments were made using a different color for each of the two generatrices. For example, in Fig. 1, AB was black and CD was white. With most background colors only one asymptote of Fig. 2 was obtained distinctly. It was rather surprising that the black rod with a black background produced a black asymptote, and the white rod with a white background produced a white asymptote. At first, this seemed to be in contradiction to the results obtained with two rods of the same color. However, a similar explanation seems to hold. The surface generated is a blend of the black and white. With a black background, when the black rod obscures the white rod the black rod and background produce a distinct dark asymptote, but when the white rod obscures the black one the combination of the white rod and background is practically the same shade as the surface, and the asymptote for the white rod does not appear. With a white background, similar reasoning explains why the white rather than the dark asymptote appears.

Shadow Effects

Some surprising shadow effects were obtained. For example, a single white ring as shown in Fig. 13 was revolved with bright daylight coming through a window at the left. An opaque screen having a two inch vertical slot was placed close to the spinning unit, between it and the window. We have already learned that a line of interference is produced which appears to be the axis of the sphere generated. This phantom axis really seems to cast a shadow on the inside of the right side of the sphere. Of course, this is impossible. The left half of the ring casts instantaneous shadows on the right half. If a sphere is generated by one-half of a ring, neither the axis nor the shadow appears. (Continued on page 9)

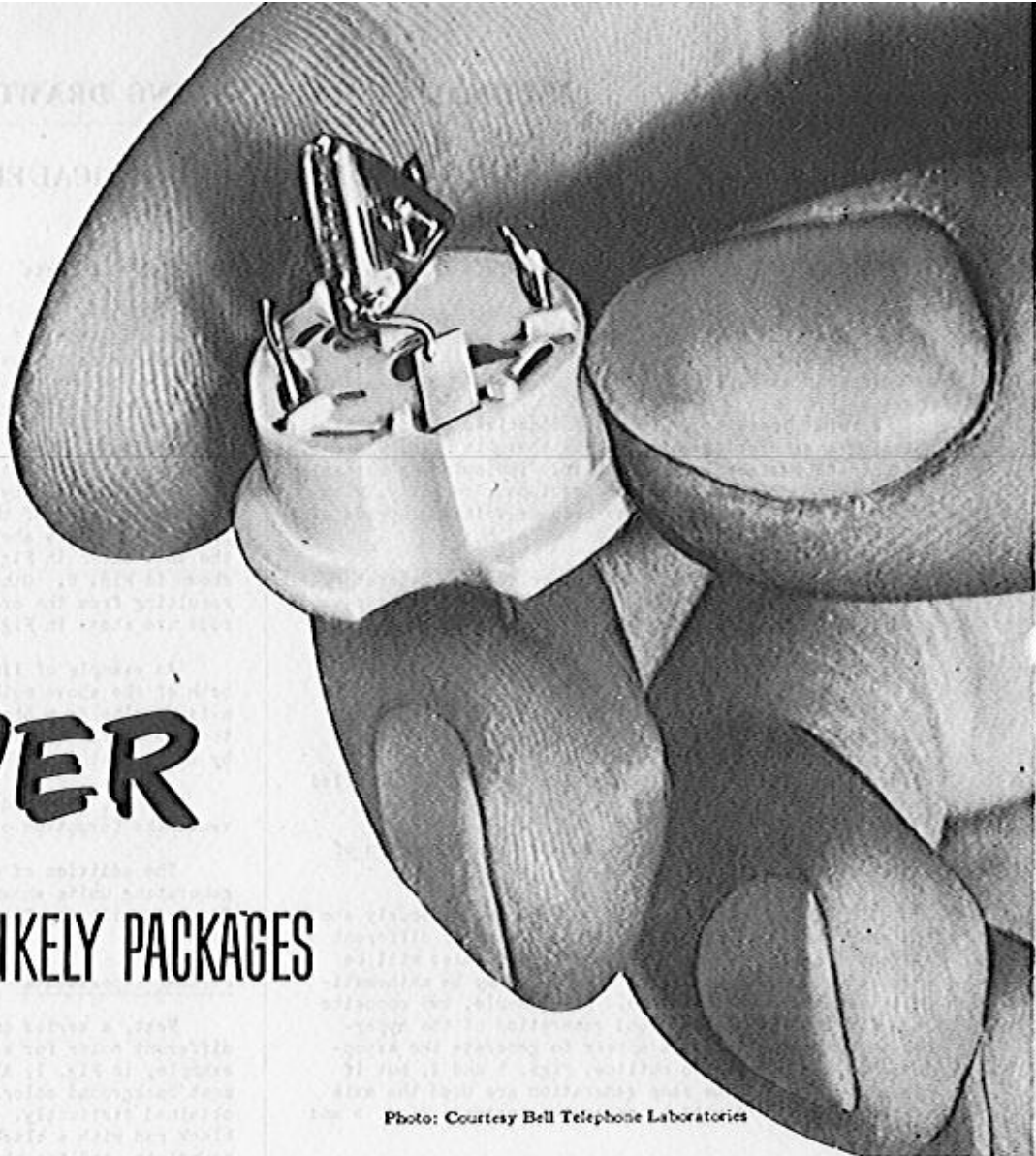

Photo: Courtesy Bell Telephone Laboratories

POWER

OFTEN COMES IN UNLIKELY PACKAGES

It used to be thought that diamonds did not conduct electricity. But physicists of the Bell Telephone Laboratories bombarded diamond chips with millionth-of-a-second bursts of electrons and discovered that the chips then yielded up to 500 times the original current. This discovery may lead to new and better types of electron tubes for long-distance communication. Thus, *power often comes in unlikely packages.*

Unprepossessing youngsters, apparently qualified only for mediocrity, have often made outstanding records of achievement and success in later life. Yet this fact need surprise no man. For just as the diamond chips possess the power which the right agent was able to reveal, so *all* youngsters with but trivial exceptions possess all the qualities *they* need for success, needing only the right influences to bring them out.

Knowing the universal desire for prestige and achievement and the equally universal possession of energy, the conscientious educator looks for ways of showing the boys in his class the possibilities that lie ahead of them, the potentialities within themselves and the road to be followed. The need is as pressing, the opportunity is as great in the class in mechanical drawing.

Here, the work points directly at the adult years, the classroom foreshadows the engineering office. Above all, the work

combines discipline of the hand and discipline of the mind. Great opportunity is presented to enthuse and inspire the beginning student, to awaken dormant ambition for high achievement, to initiate habits which will serve him well. To say it does not matter what quality of drawing instruments the student uses, to say his drawing set can be carelessly chosen and regarded with indifference, is to make this work an ill-starred venture. It is a risk no conscientious instructor will take. The only possible reason for accepting less than the best is an economy of pennies gained at who knows what cost in the future.

EUGENE DIETZGEN CO.

Chicago • New York • San Francisco • New Orleans • Los Angeles
Pittsburgh • Washington • Philadelphia • Milwaukee

Dealers in All Principal Cities



DIETZGEN

EVERYTHING FOR
DRAFTING AND SURVEYING

(Continued from page 7)

Derivation of the Equation in Cartesian Coordinates for a Curved Line of Interference.

In Fig. 10 there are two lines of interference, each a reverse curve, crossing at the center. A portion of one of these is shown in Fig. 17, which is used for the derivation of the equation of the curve. Let R , the radius of the cylinder, be used as unity. The radius r of the gorge circle is shown unequal to R . The elements of the hyperboloid make angle H with a horizontal plane, the axis being vertical. Let α be the angle of revolution between any element of the hyperboloid and its frontal generatrix. Then, with the origin at the center of the gorge circle, the coordinates for a point of interference on any element are as follows:

$x = R \sin \alpha$, which may be written
 $x = \sin \alpha$, since $R = 1$ (1)

$y = (r \tan \alpha + R \tan \alpha) \tan H = (R + r) \tan H \tan \alpha$
 Let $K = (R + r) \tan H$, a constant.
 Then $y = K \tan \alpha$ (2)

Combining equations (1) and (2) to eliminate the parameter α we obtain

$$y = \frac{Kx}{\sqrt{1 - x^2}}$$

Stroboscopic Effects.

Beautiful and interesting stroboscopic effects are produced easily by spinning the units under a single-tube fluorescent lamp placed very close to the unit for maximum intensity. The bluish daylight lamp seems to be most satisfactory. The simple generating units gives the best stroboscopic effects. Spinning the unit shown in Fig. 5 produces a hyperboloid with numerous elements spaced

uniformly around the entire surface. Spinning a circular ring about its diameter generates a sphere with meridians.

Generally, the best effects are obtained with white units spinning in front of a black background and above a black base. Colored backgrounds influence the colors seen on the generated surface, and in some cases practically eliminate them.

The speeds of our motor drive enables us to obtain 7, 8, 9, 10 or 11 flashes per revolution under a single fluorescent lamp.

Spinning speed of unit in rpm = $\frac{7200}{\text{Number of flashes per revolution}}$

A reliable drive which would deliver 1250 to 550 rpm would be preferable because 6 and 12 flashes also could be obtained.

The rod CD of Fig. 13 may be made to show as 7, 8, 9, 10 or 11 cone elements which can be made to stand still or revolve slowly in either direction. For the ring, however, the odd numbers must be doubled, giving 14, 8, 18, 10, or 22 meridians of the sphere.

At eight flashes per revolution on the unit of Fig. 13, the elements of the cone intersect the meridians, but at ten flashes the elements are midway between the meridians. These statements can be verified on the drawing board.

A real stroboscope produces similar effects. The definition is sharper but the results are not as spectacular.

Acknowledgments.

Practically the entire staff of the Department of Drawing have made helpful suggestions. Appreciation of valuable assistance is expressed to Messrs. J. D. McClung, Jack Lenhart, Melvin Eainey, J. R. Holmes, J. R. German and J. D. McFarland.

The direction of sight for a front view is indicated in the dimetric drawings which show the positions of the rods in the generating units.

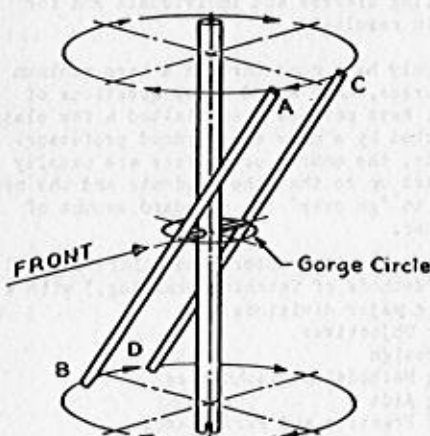

Fig. 1
Rods AB & CD, 180° apart at gorge circle, are for the first and second generation.

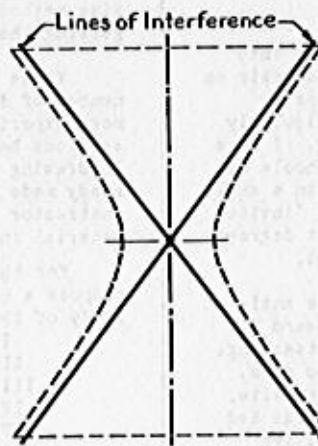

Fig. 2
Hyperboloid generated. Lines of interference appear as asymptotes of the hyperbolic outline.

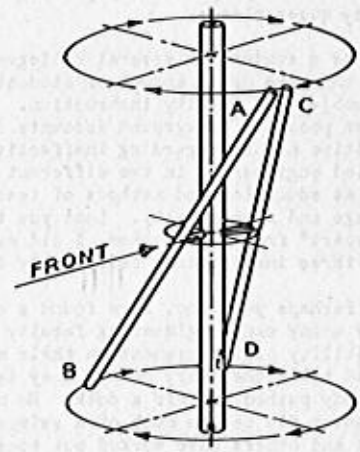

Fig. 3
Rods AB & CD, approximately 150° apart at gorge circle, are for two generations.

(Continued on page 33)

A COURSE FOR THE TRAINING OF ENGINEERING DRAWING TEACHERS

by

Professor Harold P. Skanser, Michigan State College

If you have read Prof. Spencer's article on Joe Doaks or heard his talk at the 1946 Drawing Division Summer School in St. Louis you will appreciate what I mean when I say, this is dedicated to the death of Joe Doaks.

For many years, students and instructors alike have frequently commented on the extreme range in type and quality of college instruction. Usually, the students concede that practically all instructors know the subject matter. They also admit that some men are outstanding in research or leaders in their field, yet do not seem to be effective as teachers.

This has bothered many students, a few young instructors, and once in a while, somebody in an administrative position. Apparently A. S. E. E. is beginning to do something about it through their committee on the "Improvement of Teaching." The booklet, "Effective Teaching," published by McGraw-Hill under A. S. E. E. sponsorship and edited by Fred C. Harris down at V. P. I. in Virginia is another step in the same direction.

I feel sure that you and I can both recall cases, in our own experience, of professors or instructors who were well informed yet unable to do an effective job with a group of students. Surely we are aware of the fact that some superior students do a good job in spite of the quality or kind of instruction, but we can't lean too heavily on that. I believe that one indicator of high quality instruction is success by a large percentage of a class.

I have long since come to the conclusion that there is something more to good teaching than just picking up a few pointers and ideas after graduation. The original system for obtaining an Engineering Drawing faculty member was not too unlike the child's game of "Pin the Tail on the Donkey." We allow a student to whirl through a few courses in drawing, put a text in his hand, give him a pat on the back and lo, we have a teacher. It is not surprising that some people end up putting that tail in some mighty queer places.

As a student in several colleges, I have run into more than the usual amount of student wails of despair on the subject of quality instruction. And, perhaps my rather peculiar background accounts for my particularly sensitive nature regarding ineffective teaching. I have studied engineering in two different Big Ten Schools as well as education and methods of teaching both in a small college and a university. Lest you think I was "invited to depart" from all of them, I did manage to get degrees from three institutions before they found me out.

Perhaps you, too, have found a considerable antipathy among many engineering faculty members toward the possibility of improvement in their methods of teaching. My Dad tells the story of how they taught him to swim. Somebody pushed him off a dock. He managed to survive, but never did become much of a swimmer. By now the Red Cross and others have worked out some very effective step-by-step methods. The Red Cross method was one of the first things that brought home to me how efficient and effective better teaching methods can be. I taught over 100 boys how to swim in less total time than it took me to learn on my own with very amateurish instruction. It took

me a long time to unlearn the bad habits which my lack of effective instruction had permitted me to develop.

Good teaching is an art and even something of a science. As long ago as the golden age of Greece, Cicero said, "Not only is there an art in knowing a thing, but also a certain art in teaching it."

Back in the revolutionary days, Roger Ascham in the Schoolmaster, a publication of those times, said, "Learning teaches more in one week than experience in twenty." I believe the great majority of young drafting instructors would profit by some training on how to teach more effectively.

I will grant there is some justification for the criticism by engineering faculties directed toward some poor teachers who are in education departments. There is considerable finger-pointing at things, about which so-called authorities in education disagree. Of course, many of the things about which there is a divergence of opinion have not yet been settled. There are some things, too, about which there has been disagreement for many years. This is a natural condition, and to be expected, in a field dealing with human nature when there is an almost infinite number of variables and intangibles. Then too, different men can get good results with slightly different methods. There are a few things left to work out even in our concrete field of engineering.

There is, however, a great body of fundamental and useful knowledge about which there is general concurrence and agreement. I refer to some of the basic principles of learning and some of the basic factors of practical psychology.

Since the end of the recent World War, there has been a great influx of new instructors into our field. If these beginners have had the typical preparation of the past, they may be fairly good engineers and pretty good draftsmen, but perhaps rather ignorant of some of the more effective methods of handling classes and individuals and for getting the maximum in results.

These men, commonly have gone through a bare minimum number of drawing courses, have asked a few questions of more experienced men, have perhaps even visited a few class sessions being conducted by a more experienced professor. In drawing departments, the course or courses are usually ready made and well set up so that the students and the new instructor do manage to "go over" the standard amount of material in some manner.

For these new post-war instructors and others I would propose a course in "Methods of Teaching Drafting," with a study of the following major divisions:

- I. Goals or Objectives
- II. Course Design
- III. Teaching Methods and Techniques
- IV. Teaching Aids
- V. Drafting Practice and Performance
- VI. Evaluation

The class should have two lecture periods and three double periods in the drafting room each week. Please follow the course outline on the next page as I continue my discussion.

A COURSE IN METHODS OF TEACHING IN DRAFTING
COURSE PROGRAMS AND ACTIVITIES

	MAX. TIME WEEKS
I. Goals.	
A. Objectives of the methods course.	(Term basis) (Class has 2 lectures and 3 double period laboratory meetings per week)
B. Objectives of a fundamental drafting course.	
C. Study and set-up of aims and objectives of fundamental courses in drafting.	
D. Analysis and summary of what a student should know, understand, be able to do, when he has completed his basic training in drafting.	
	1 wk.
II. Course Design.	
A. Survey of the field of drafting.	1 wk.
B. Surveys of national practice in engineering drawing.	
C. Survey of class and community needs.	
D. Steps in course construction.	
E. Setting up course outline.	
III. Teaching Methods and Techniques. (Application of some principles of learning and applied psychology.)	
A. General methods and techniques in teaching drafting.	4 wks.
B. Planning a unit of work, and making lesson plans, assignments, etc.	
C. Making a job analysis and designing problems to accomplish the aims and objectives set up.	
D. Making individual instruction sheets.	
E. Course flexibility and provisions for individual differences.	
F. Study and practice of certain teaching techniques.	
1. Demonstrations at the blackboard.	
2. Demonstrations at the drafting table.	
3. Lectures, discussions, and recitations.	
G. Motivation and Attitudes.	
H. Class Management, discipline and group psychology.	
IV. The use of Teaching Aids and Devices, etc.	
A. Selection and use of the textbooks, workboards, problem sets, etc.	2½ wks.
B. Equipment and supplies: evaluation of materials, management of equipment, inventory, maintenance, planning a drafting room, reproduction methods, etc.	
C. Visual and audio aids (including models).	
D. Special methods and devices for improving drafting techniques. Also drafting standards, and sources of samples of good practice.	
E. Correlation with the various related fields, industrial contacts and field trips, etc.	
V. Drafting Practice.	
A. Refresher, etc. in the Drafting Room.	2½ wks.
B. Completion of any phases neglected in past training.	
VI. Evaluation.	
A. Mutual and self-criticism, rating charts, etc.	1 wk.
B. Grading: systems and methods of evaluation.	
C. Functions of tests and testing, and the design of good tests.	
D. Evaluation of the Methods Course by its students.	
TOTAL	12 wks.

I. Goals or Objectives.

The purpose of the methods course is to better prepare men to teach drafting; to teach them how to avoid the common errors and pitfalls of mediocre and poor instructors; to open their eyes to possibilities and potentialities in their field. We would try to show them what is being done, what can be done and some of the better and newer methods and techniques of teaching. We would try to make them fully aware of the objectives of a drafting course and to develop a philosophy of life insofar as teaching is concerned. Objectives of drawing would be considered from the point of view of the teacher, the student, and subject matter. The instructor should be made to realize that aims are a guide to methods and an aid in the selection of material. The relation of specific drawing objectives to those of the general field of engineering and education in general should be considered. A number of sample sets of objectives from various sources would be presented to the student. We would also endeavor to call the "best from past experience" for their benefit.

A tourist visited a large structure under construction in Europe and during his inspection asked questions of three of the craftsmen. When he asked the first one what he was doing, the laborer answered, rather grumpily, that he was laying bricks. The second said he was building a wall, and the third workman boasted that he was building a great cathedral. Similarly, a student must see the ultimate purpose if he is going to be at all inspired. Else he bogs down at just laying bricks. Do you know any instructors who are just "laying bricks?" And I wonder, if some of our students aren't just drawing a plate to get it finished and to hand it in.

II. Course Design.

The student would make a brief survey of the field of drafting, study course design, and some surveys of national practices. They should become aware of the steps in course construction, and would also study and discuss, just a little the influence of class and area needs. The student then works out a "course outline" for the type of situation he thinks he is most likely to encounter in the near future. He would later make a unit outline for some section of drawing in which he is particularly interested.

III. Teaching Methods and Techniques.

The largest, and perhaps the most important section of the term's work is concerned with a study of teaching methods and techniques and their use. The first lecture introduces the student to the proper functions of a teacher while in the classroom. It summarizes the seven factors the instructor should consider in preparing to teach a lesson or unit. It also includes many of the ordinary ways of learning and goes into some detail on the three most common methods.

A considerable amount of time will be spent in the study and practice of methods of demonstrating at the blackboard, drafting table, and in conducting discussions and recitations. Approximately 30-40 such demonstrations are to be criticized, evaluated, and fully discussed by the class. During this time, the student carries on two major activities more or less concurrently for an extended period of time. He begins to prepare himself for the series of demonstrations at the blackboard, drafting table, etc. Several lectures and other materials are presented on techniques. For several weeks the first hour of laboratory would be spent on demonstrations, etc., and the second hour would be devoted to one major job each week. For the first week on part III the second hour is devoted to making a unit outline, learning some things about lesson planning, etc. The lecture on lesson plans includes the preliminary steps a teacher should take in planning lessons and units. A more detailed study is made of the four parts of a well-taught lesson; preparation, presentation, application, and checking or testing. The student makes out lesson plans for his unit. Information on visual aids and methods of providing for individual differences is made accessible at this time.

(Continued on page 29)

FUNDAMENTALS OF ENGINEERING DRAWING, Revised

By WARREN J. LUZADDER, PURDUE UNIVERSITY

The basic principles of engineering drawing are here presented in such a way that the beginning student can find satisfying answers for all of his ordinary questions. Written in simple, understandable language, the major portion of the text leads up to the preparation of machine drawings. The methods used in such preparation are the same as those in other fields of engineering. Thus the student is given a good foundation for later study in some specialized field such as structural drawing. This revised edition includes many improved illustrations.

Published 1946 • 623 Pages • 6" x 9"

PROBLEMS IN ENGINEERING DRAWING, Third Edition

By WARREN J. LUZADDER, J. N. ARNOLD, PURDUE UNIVERSITY and F. H. THOMPSON;
UNIVERSITY of CALIFORNIA (BERKELEY)

For use with any standard text, this revised edition features:

- Over one-half the problems completely new
- Every problem from the previous edition redrawn
- All lettering completely uniform
- 69 problems on manila-type, drafting, graph and regular bond paper
- Loose sheets, inserted in a heavy envelope with a booklet of instructions.

Published September 1950 • 71 Plates • 8½" x 11"

DESCRIPTIVE GEOMETRY

By EARLE F. WATTS and JOHN T. RULE, MASSACHUSETTS INSTITUTE of TECHNOLOGY

Covering the basic material of elementary graphical theory applicable to engineering problems, this text develops the ability to solve such problems by the simplest graphical methods. It does not limit the student to one method of attack in solving problems. All methods are thoroughly described, enabling the student to choose the simplest solution to each problem.

Published 1946 • 301 Pages • 6" x 9"

PROBLEMS IN DESCRIPTIVE GEOMETRY

By EARLE F. WATTS and ARTHUR L. GOODRICH, MASSACHUSETTS INSTITUTE of TECHNOLOGY

These problems have been selected to illustrate the fundamentals of descriptive geometry, the special methods which branch out from those principles, and the application of those methods to the graphical solution of engineering problems. They are designed to correlate with Watts and Rule's DESCRIPTIVE GEOMETRY.

Published 1946 • 64 Plates • 8½" x 11"

Send for your Copies Today!

PRENTICE-HALL, Inc.

70 FIFTH AVENUE

NEW YORK 11

A SURVEY OF SUPERVISED CLASS HOURS REQUIRED IN GRAPHICS COURSES

by

Professor T. C. Brown
North Carolina State College

Purpose of the Study.

The Drawing Division staff of N. C. State College has felt a need for evaluating the courses and the teaching methods used at this school. With the knowledge and sincere belief that Basic Graphics constitute one of the fundamentals in all engineering curricula, a study has been started to determine, first of all, what our possibilities are as compared with other schools in the nation. The Drawing Division staff also realizes the paramount importance of good teaching in these basic courses since it is in this area that the engineering student first begins to orient himself in his chosen field.

The purpose of this study, therefore, is to determine the amount of time that the students are in class under the supervision of the teacher. The study emphasizes the amount of time at the teachers disposal for teaching the students in these Basic Graphics courses.

Limitations.

Since credit hours are not universally equal, it was decided that the number of hours of supervised instruction (hours on class) which each student received would be a more accurate unit of measurement for comparing the opportunities for optimum achievement by the student.

Questionnaires were sent to land-grant college, state universities, and the larger schools of engineering as listed by the American Society of Engineering Education. A total of 130 schools were solicited and 107 of these replied. Of those replying, only 99 were suitable for inclusion in the survey because of various reasons. Brown University, Stanford University, Columbia, and CCNY returned their questionnaires too late to be included; the University of Chicago reported they offer no engineering degrees; Harvard does not classify their undergraduate courses nor their students; and, the Naval and Military Academies do not attempt to achieve objectives similar to those of a more diversified engineering school.

Method of Procedure.

The questionnaire was designed to require a minimum of time to answer and self-addressed, stamped envelopes were included for convenience.

The data was assembled as received and charts were designed to graphically illustrate the results.

Any course listed as a first year course was considered as a basic course and any course listed as a first and second year course was considered as advanced in the second year.

Interpretation of the Data.

Figure 1 is a sample of the questionnaire used.

Charts were designed and assembled for the Engineering School (all departments); and, the following engineering departments: mechanical, chemical, electrical, civil, industrial, and ceramic.

Engineering School (Figs. 2, 3 and 4)

Figure 2: This chart is the sum total of all graphics courses (freshman and sophomore levels)

offered in the various engineering schools. These courses included basic engineering drawing, basic descriptive geometry, advanced engineering drawing, and advanced descriptive geometry. The average amount of graphics offered was 274 hours on class.

Certain schools do not require all of the engineering students to take all of the offered courses; therefore, some of the schools do not show a full utilization of courses offered. This amount is illustrated by the horizontal line appearing across some of the columns.

Civil Engineering.

Average amount of total graphics (freshman and sophomore levels) is 240 hours.

Drawing Division
N. C. State College
Raleigh, N. C.

Dear Fellow Teacher of Engineering Drawing and Descriptive Geometry:

In order that we may further the study of our drawing courses within the various curricula here and compare them with those of the nation, we are sending this questionnaire to 130 of the outstanding engineering schools of the country. If you will allow us a few minutes of your time to check the answers, we will be grateful.

	Mechanical	Electrical	Civil Engr.	Chemical Engr.	Descriptive	Mining Engr.	Metallurgical	Industrial	Arch. Engr.	A.E. Engr.	Petroleum Engr.	Ceramic Engr.	General Engr.	Process Engr.	Aer. Engr.	Military Engr.	Marine Engr.	Other
Departments taking basic engineering drawing																		
Departments taking basic descriptive geometry																		
Departments taking advanced engineering drawing																		
Departments taking advanced descriptive geometry																		

Grand total clock hours of contact
(Lab plus lecture)

Basic Engineering Drawing _____
 Basic Descriptive Geometry _____
 Advanced Engineering Drawing _____
 Advanced Descriptive Geometry _____

	Time Given During College Curriculum			
	1st Year	2nd Year	3rd Year	4th Year
Basic Engineering Drawing				
Advanced Engineering Drawing				
Basic Descriptive Geometry				
Advanced Descriptive Geometry				

	Drawing		Descriptive	
	Yes	No	Yes	No
Do you assign outside work?				
Reading assignments				
Sketches				
Drawings				

Are you interested in these results? Yes _____ No _____

We appreciate your cooperation. Enclosed is a stamped, self-addressed envelope to facilitate the return of this questionnaire.

Sincerely yours,

T. C. Brown
T. C. Brown
Associate Professor

Figure 1

Basic engineering drawing (freshman level) required by all civil engineering departments.

Average -- 136 hours.

Basic descriptive geometry (first course) required by 95% of civil engineering departments.

Average -- 86 hours.

Advanced engineering drawing (sophomore level) required by 19% of civil engineering departments.

Average -- 101 hours.

Advanced descriptive geometry (second course) required by 4% of civil engineering departments.

Average -- 71 hours.

Industrial Engineering.

Average amount of total graphics (freshman and sophomore levels) is 234 hours.

Basic engineering drawing (freshman level) required by all industrial engineering departments.

Average -- 139 hours.

Basic descriptive geometry (first course) required by 89% of industrial engineering departments.

Average -- 84 hours.

Advanced engineering drawing (sophomore level) required by 22% of industrial engineering departments.

Average -- 87 hours.

Advanced descriptive geometry (second course) required by 2% of industrial engineering departments.

Average -- 60 hours.

Ceramic Engineering.

Average amount of total graphics (freshman and sophomore levels) is 241 hours.

Basic engineering drawing (freshman level) required by all ceramic engineering departments.

Average -- 137 hours.

Basic descriptive geometry (first course) required by 85% of ceramic engineering departments.

Average -- 87 hours.

Advanced engineering drawing (sophomore level) required by 29% of ceramic engineering departments.

Average -- 70 hours.

Advanced descriptive geometry (second course) required by 7% of ceramic engineering departments.

Average -- 36 hours.

Results.

Engineering School (all departments)

1. Total graphics (freshman and sophomore levels)
Required in all curricula by more than half of the schools surveyed.
Average amount required -- 274 hours.
2. Basic Engineering Drawing (freshman level)
Required in all curricula by all of the schools surveyed.
Average amount required -- 135 hours.
3. Basic Descriptive Geometry. (First course)
Required in all curricula by 75% of the schools surveyed.
Average amount required -- 86 hours.
4. Advanced Engineering Drawing (Sophomore level)
Required in all curricula by 8% of the schools surveyed.
Required in one or more curricula by 42% of the schools surveyed.
Average amount required -- 93 hours.
5. Advanced Descriptive Geometry (second course)
Required in all curricula by none of the schools surveyed.
Required in one or more curricula by 8% of the schools surveyed.
Average amount required -- 62 hours.

Mechanical Engineering.

Average amount of total graphics (freshman and sophomore levels) is 264 hours.

Basic engineering drawing (freshman level) required by all mechanical engineering departments. Average -- 131 hours.

Basic descriptive geometry (first course) required by 97% of mechanical engineering departments. Average -- 84 hours.

Advanced engineering drawing (sophomore level) required by 37% of mechanical engineering departments.

Average -- 94 hours.

Advanced descriptive geometry (second course) required by 7% of mechanical engineering departments.

Average -- 64 hours.

Chemical Engineering.

Average amount of total graphics (freshman and sophomore levels) is 216 hours.

Basic engineering drawing (freshman level) required by all chemical engineering departments. Average -- 136 hours.

Basic descriptive geometry (first course) required by 75% of chemical engineering departments. Average -- 87 hours.

Advanced engineering drawing (sophomore level) required by 13% of chemical engineering departments.

Average -- 99 hours.

Advanced descriptive geometry (second course) required by 2% of chemical engineering departments.

Average -- 54 hours.

Electrical Engineering.

Average amount of total graphics (freshman and sophomore levels) is 239 hours.

Basic engineering drawing (freshman level) required by all electrical engineering departments.

Average -- 136 hours.

Basic descriptive geometry (first course) required by 88% of electrical engineering departments.

Average -- 87 hours.

Advanced engineering drawing (sophomore level) required by 16% of electrical engineering departments.

Average -- 96 hours.

Advanced descriptive geometry (second course) required by 2% of electrical engineering departments.

Average -- 54 hours.

Summary.

1. Total amount of graphics offered averages 274 clock hours.
2. Total amount of graphics used averages about 240 clock hours.
3. Average amount of basic engineering drawing is about 135 hours.
4. All schools and curricula require basic engineering drawing.
5. Average amount of basic descriptive geometry is about 87 hours.
6. Three-fourths of the schools surveyed require basic descriptive geometry in all curricula.
7. An average of 93 hours of advanced engineering drawing is offered by 42% of the schools surveyed and required in all curricula by 8%.
8. An average of 62 hours of advanced descriptive geometry is offered by 8% of the schools surveyed.
9. Three-fourths of the schools surveyed require outside reading in both drawings and descriptive geometry.
10. Forty-three per cent of the schools surveyed require outside sketching in drawing and outside sketching in descriptive geometry.
11. Twenty-four per cent of the schools surveyed require outside drawing in drawing and outside sketching in descriptive geometry.
12. Twenty per cent of the schools surveyed require outside reading, sketching, and drawing in both drawing and descriptive geometry.

ALL GRAPHICS COURSES
ENGINEERING SCHOOL
(ALL DEPARTMENTS)
Fr. & Soph. Levels

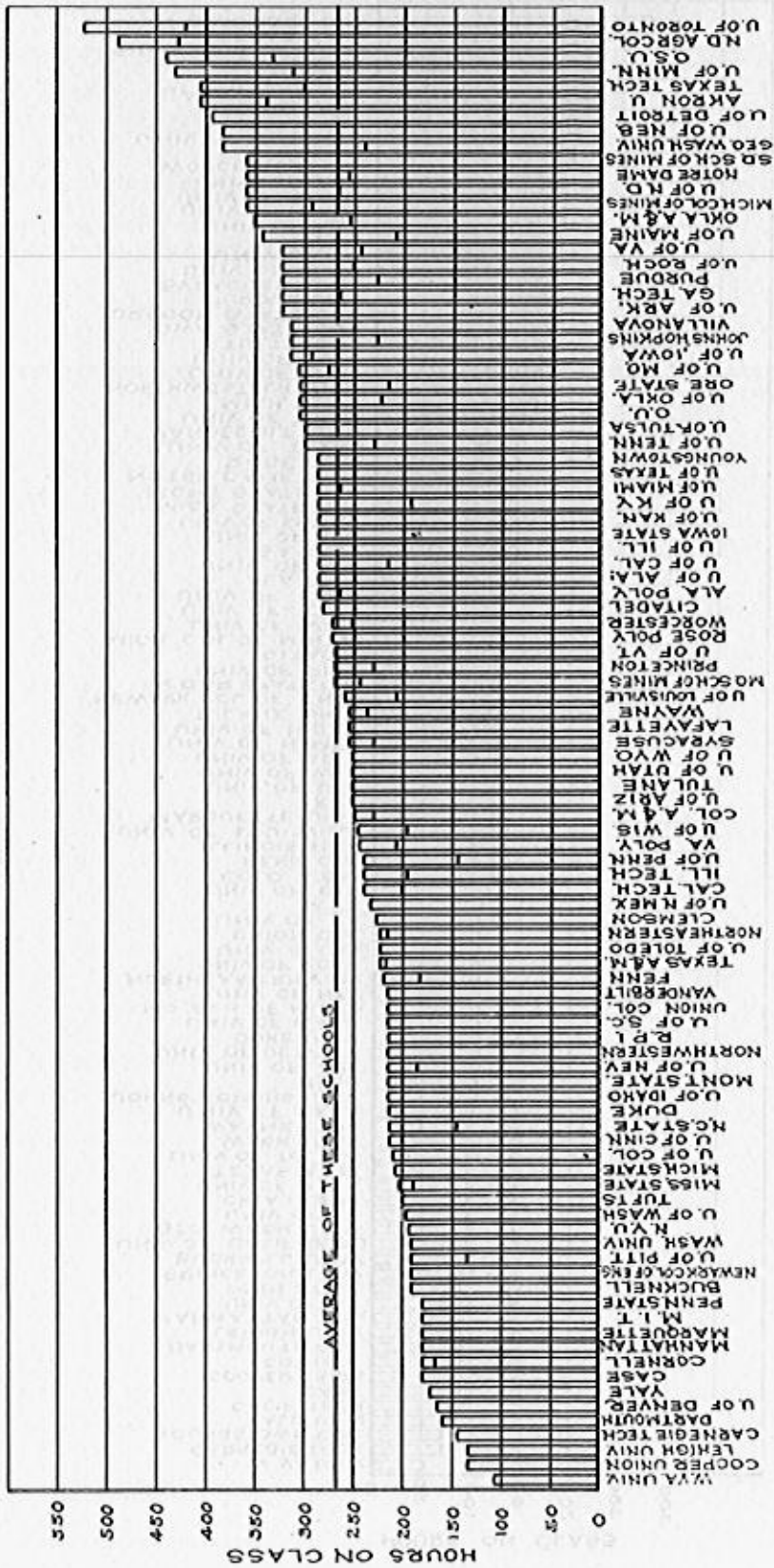

Figure 2 ENGINEERING DRAWING (MT. DEWITT MEMORIAL ENGINEERING SCHOOL)

BASIC ENGINEERING DRAWING
ENGINEERING SCHOOL
(ALL DEPARTMENTS)

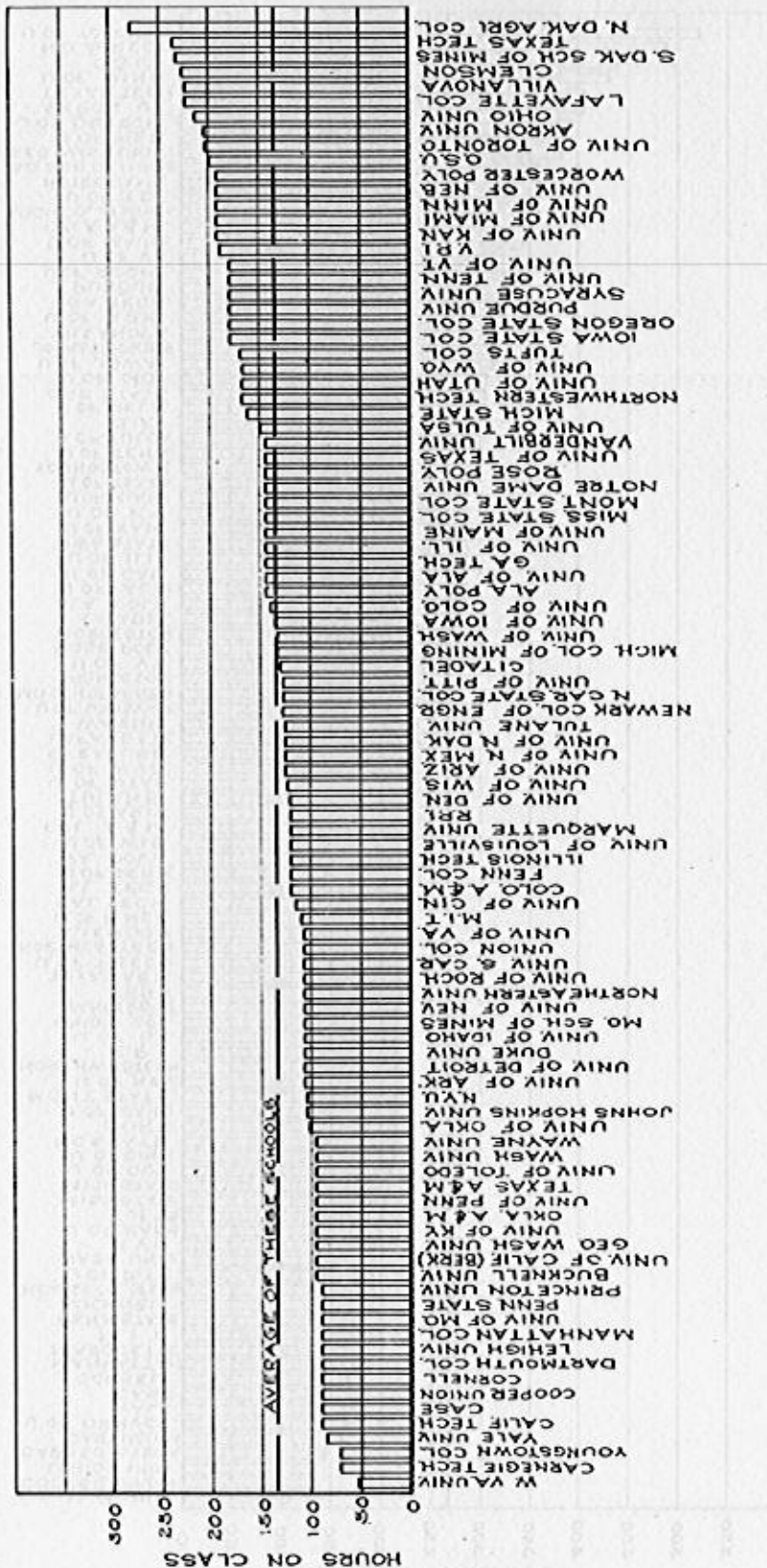
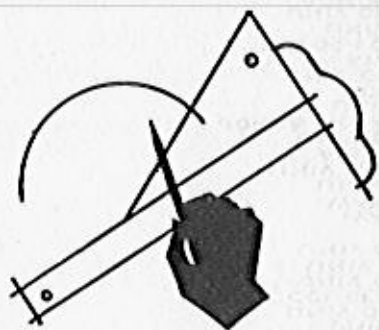

Figure 3

Perfectly designed

for
students
in



ENGINEERING DRAWING

ENGINEERING DRAWING 7th Edition

By THOMAS E. FRENCH. Revised by CHARLES J. VIERCK and associates of the Department of Engineering, The Ohio State University. 694 pages, \$4.50

Over a million copies of this famous encyclopedia of engineering drawing are now in print. Here, in the fully revised 7th edition, the text contains, in addition to much of the material praised in previous editions, added information and new techniques developed in recent years. Unusually broad in scope, *Engineering Drawing* offers invaluable reference material—standard dimensions, graphical symbols, etc.; directions in the selection and care of instruments, their use, the theory of projection drawing and the best methods of illustration; the elements of aircraft, architectural, and structural drawing and practical information on map drawing, graphing of all types, and the construction of diagrams. In addition to this comprehensive coverage, over 1000 illustrations clarify the text and further help to make this book a leader in the engineering and drafting professions for over three decades.

PROBLEMS IN ENGINEERING D

By A. S. LEVENS and A. I.
In press

A complete revision of this set keyed to French's *Engineering* the important subject of dimensioning. Special features of the revision on dimensioning increasing the series of lettering sheets, based 3) several desirable changes in 4) an increase in the total number of sheets, permitting a wider selection.

Send for copy

McGraw

330 West 42nd

LESSONS IN LETTERING New 3rd Edition

By THOMAS E. FRENCH and WILLIAM D. TURNBULL. Revised by A. J. PHILBY, The Ohio State University. Ready in October.

Book I. Vertical Single Stroke 40 pages, 60¢

Book II. Inclined Single Stroke 40 pages, 60¢

The new revision of *Lessons in Lettering* represents a complete modernization of these excellent manuals. All numerals and fractions have been changed to conform to the American Standard Drafting Practice; new sheets are provided on pictorial lettering and the technique of dimensioning. In addition there are treatments of the new American Lettering Instrument Design, the new Speedball Flicker Pen, and enlarged examples of the open and closed types of arrowheads.

INDUSTRIAL PRODUCTION ILLUSTRATION

By RANDOLPH PHILIP HOELSCHER and CLIFFORD HARRY SPRINGER, University of Illinois, and RICHARD F. POHLE, ASF Maintenance Division, Washington, D. C. Second edition. 243 pages, \$5.50

This book covers the entire range of pictorial drawing, from both the theoretical and practical points of view, for those who wish to do production illustration in the aircraft, shipbuilding, ordnance, automotive, or other industrial fields. The three forms of pictorial representation are clearly covered, with the sound basis of theory; methods of laying out and shading sketches; and practice material, needed in acquiring proficiency both in exact mechanical construction and in the more rapid freehand method.

DESIGN OF MACHINE MEMBERS

By ALEX. VALLANCE and VENTON LEVY DOUGHTIE, University of Texas. Second edition. 559 pages, \$5.25

Using the subject of kinematics, mechanics, and factory processes as a foundation, this book explains to the student the theory involved in the design of the elements of operating machines, and points out the variations from theory required by practical applications. This treatment maintains an excellent balance between theory and practice and provides an unusually broad coverage of the field.

AWING

AWING III

EDSTROM, University of California.

engineering drawing problems
awing, 7th ed. The treatment of
ioning is greatly strengthened.
clude 1) Six new problem sheets
al to twelve 2) a completely new
recommended A.S.A. practices
e section on freehand sketching
er of problem sheets to 78, per-

s on approval

-HILL BOOK COMPANY, INC.

Street

New York 18, N. Y.

STANDARDS AS A TOOL FOR THE ENGINEERING GRADUATE

by

T. W. Ragan
Western Electric

Standards are used in practically every phase of the operations of the Bell Telephone System and the Western Electric Company. We regard them as tools of the utmost importance. This discussion will be confined to the use of manufacturing standards by the Western Electric. I regret that time will not permit me to cover Bell System participation in national standardization nor explain how standards are used in our research laboratories in several states and operating companies in every state in the Union.

Before we take up the value of manufacturing standards, I believe it would be helpful for you to have a brief picture of standardization which is one of the broadest of all subjects. This should include a good definition and a few common examples. The Encyclopedia Britannica states that standardization means setting up standards so that quantity, quality, value, performance and service may be gaged. Standards reduce economic waste and are needed to provide a common language so that the buyer and seller can deal with each other fairly and intelligently. We have standards to provide uniformity in the products of different suppliers, interchangeability of parts (and this is most important), lower manufacturing costs and reduced selling costs to the public through simplification of types and sizes. The ASA tells us that a standard is a solution of a recurring difficulty; and that standards are a temporary statement of requirements which should be revised at periodic intervals so that they will never put a brake on the improvement of products and processes. While these definitions are good, I personally prefer this one - "A standard is a statement of the best way we know how to do a thing today".

Standards are so much a part of our daily life that few of us appreciate their value or the extent to which they shape our lives. In a telephone conversation this week with Professor Carlson, he mentioned that this program started at 2:30 P.M. It would be interesting to know if he thought of the hour and minutes as international standards of time and the P.M. as a standard abbreviation for afternoon. Driving out to Evanston, we were halted many times by the red stop light. While waiting for the light to change to green, I looked around at other drivers and wondered if they realized that traffic lights are one of our many national standards. Many other common examples of standards could be given such as money, the railroad track gage and couplings, the 110 volt current for homes, screw threads, etc.

Let's get on to Western Electric standardization which covers a very broad field. In our 29 manufacturing locations in several different states, there are over 71,000 people engaged in making the many varieties of telephone products. The value of this product in 1948 was over one billion dollars. We have a tremendous investment in plant, machinery, tools, materials and miscellaneous equipment. In this connection, let's not overlook the investment in employees. To efficiently manage and operate this high manufacturing organization and keep the different plants together, many standards are used.

To help you visualize what these standards are and how they are used, let's imagine that you are a young Western Electric Product Engineer on Step-by-Step

Apparatus and our Bell Telephone Laboratories in New York City have designed a new Step-by-Step Switch Unit. As most of you know, research and development activities in the Bell System are carried on by this group of scientists, physicists, engineers, chemists, etc. In due time the working model, along with specifications and drawings comes out to you.

Comments on Connector Switch

Figure 1 is a Connector Switch Unit and is the last switch used in a call between two subscribers in the Step-by-Step Dial System. The major components cover items such as relays, condensers, magnets, relay mounting plate, banks, shaft and switch frame. The frame will be discussed later. There are 1200 different parts in this switch and a total of 2200 parts. In 1948 we built 800,000 of this and associated switch units.

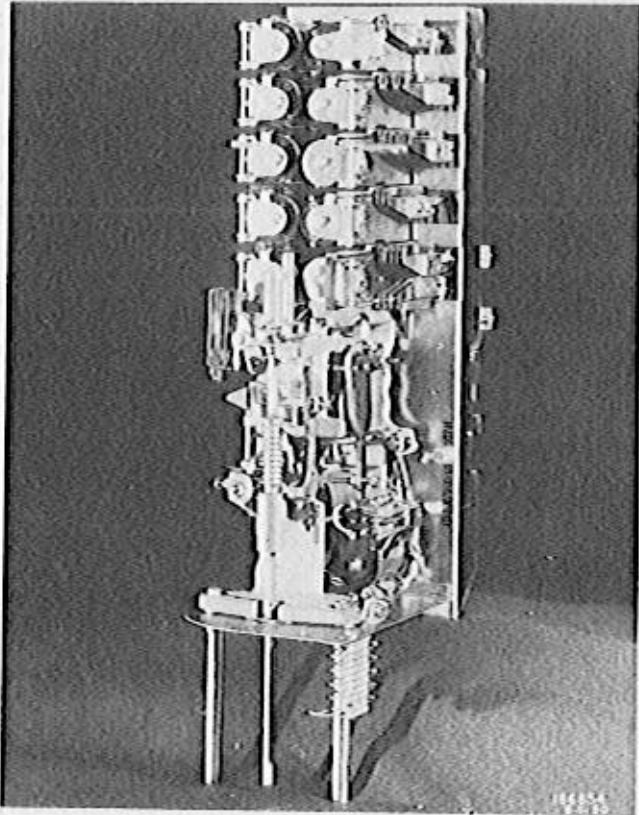

Figure 1
Connector switch unit for
Step-by-Step Telephone
Dial Switching System.

As a Product Engineer, you have the responsibility of providing the manufacturing facilities, such as plant,

machinery, tools, gages, etc.; determining the method of making and assembling component parts; estimating the cost of each part and estimating the cost of the final product. Obviously one engineer would not do all of these things on a large unit of apparatus. Actually, 14 engineers are working on various codes of switch units. Also, many other engineering organizations will give you service in specialized fields upon request.

Now engineering for manufacture was never an easy job and many factors must be considered.

Switch Frame

An excellent example of this is the cast iron switch frame which is common to all the different codes of switch units (another standard). Figure 2, left, shows the frame as it is received from the foundry and Figure 2, right, after all machining operations have been completed.

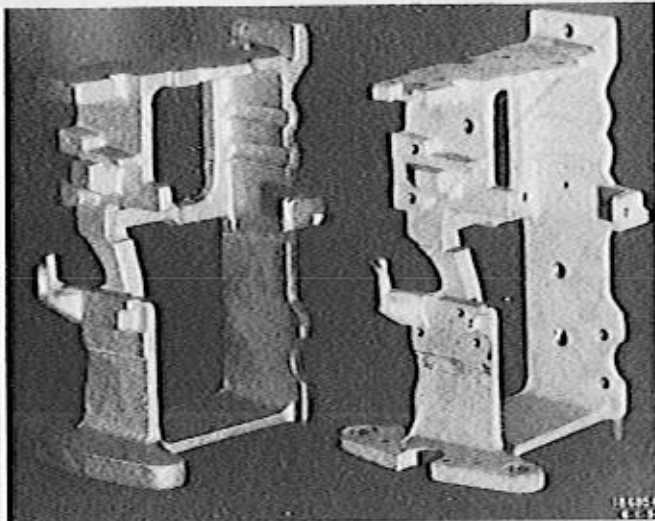

Figure 2

Frame, for Step-by-Step switch (material, cast iron) as received from Foundry (left) after completion of all machining operations (right).

To further emphasize the engineering thinking put on this one part, Figure 3 illustrates a new aluminum die casting switch frame which is now in the development stage. Figure 3, left, is a sample of the casting as produced by the die casting machine and tool. As a matter of information, a 400 ton HP¹ Cold Chamber Die Casting Machine is used along with a very special die casting die. An injection pressure of 20,000 pounds per square inch is exerted in this die. Figure 3, center, illustrates the die casting after trimming and straddle milling on 5 surfaces. The final part following all machining operations is shown in Figure 3, right.

You will note from Figure 4 of the aluminum die casting frame blank that datum lines and planes have been shown for the purpose of fixing critical positions for locating purposes. As you have noted from preceding comments, the slotted openings fixed by the intersection of the datum line and planes 1, 2 and 3 are most important. These openings are used to control all subsequent operations including gaging.

This picture shows that each industry has its own

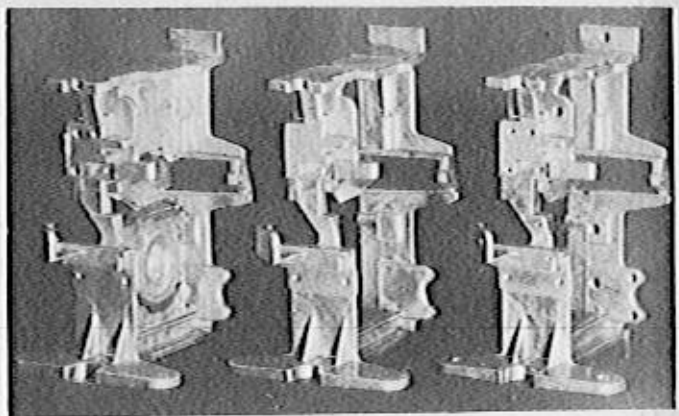

Figure 3

Frame, for Step-by-Step switch (material, aluminum alloy) as produced by the die casting machine (left), after the trimming and straddle milling operations on 5 surfaces (center) and after all machining operations (right).

type of product, and manufacturing facilities and techniques are usually different in each company. The conventional handbooks have their purpose but often are of little help--special tools are needed to do this job in the most efficient manner and at the lowest possible cost. Because of this, the Western Electric has provided you with a number of Manufacturing Standards. I will give a brief description of a few of them that would be used in the manufacture of the new switch unit.

Plant Standards are used in making a building floor plan showing the most economical arrangement of plant facilities, machines and bench positions. Heating and ventilating, toilet and washroom, fire protection, material handling, lighting and power standards are included in this group. Drafting Standards are helpful in converting the Laboratories' design or engineering drawings to manufacturing drawings and in writing associated change orders. Since you are especially interested in this field, I will discuss this topic later in more detail. Much could be said on this subject. Standard Manufacturing Tolerances (16,001) are a guide in limiting specific dimensions on product drawings and as an indication of the general quality or accuracy that can be expected from various machining operations. This book is widely used in the shop and by apparatus draftsmen and engineers.

General Manufacturing Data (16,003) is a supplement to our manufacturing drawings. Among other things, it was created to eliminate frequent repetition of standardized information, both Company and national, on telephone apparatus drawings. It provides tabulated data on many items such as screw threads, general use fastening devices, abbreviations, precious metal contacts, cast alloy mixtures, wood working joints, limiting of drawings (to be discussed later) and torque values for screws. This book is also widely distributed to the shop, draftsmen and engineers.

Piece Part Planning Standards (16,005) aid in the preparation of manufacturing layouts, calculating tool capacity and ordering the proper number of tools. The section on Tool Planning Data is of real value to the planning engineer. For example, data is given for the

(Continued on page 23)

BRADDOCK LETTERING ANGLES

DESIGNED FOR STUDENTS, ENGINEERS,
DRAFTSMEN AND ARCHITECTS

THE BRADDOCK LETTERING ANGLE HAS THREE USES:

1. As an ordinary standard triangle, it is exceedingly accurate.
2. It is used to obtain uniformly and accurately spaced lines for lettering.
3. It is used to obtain parallel lines at uniform spacings.

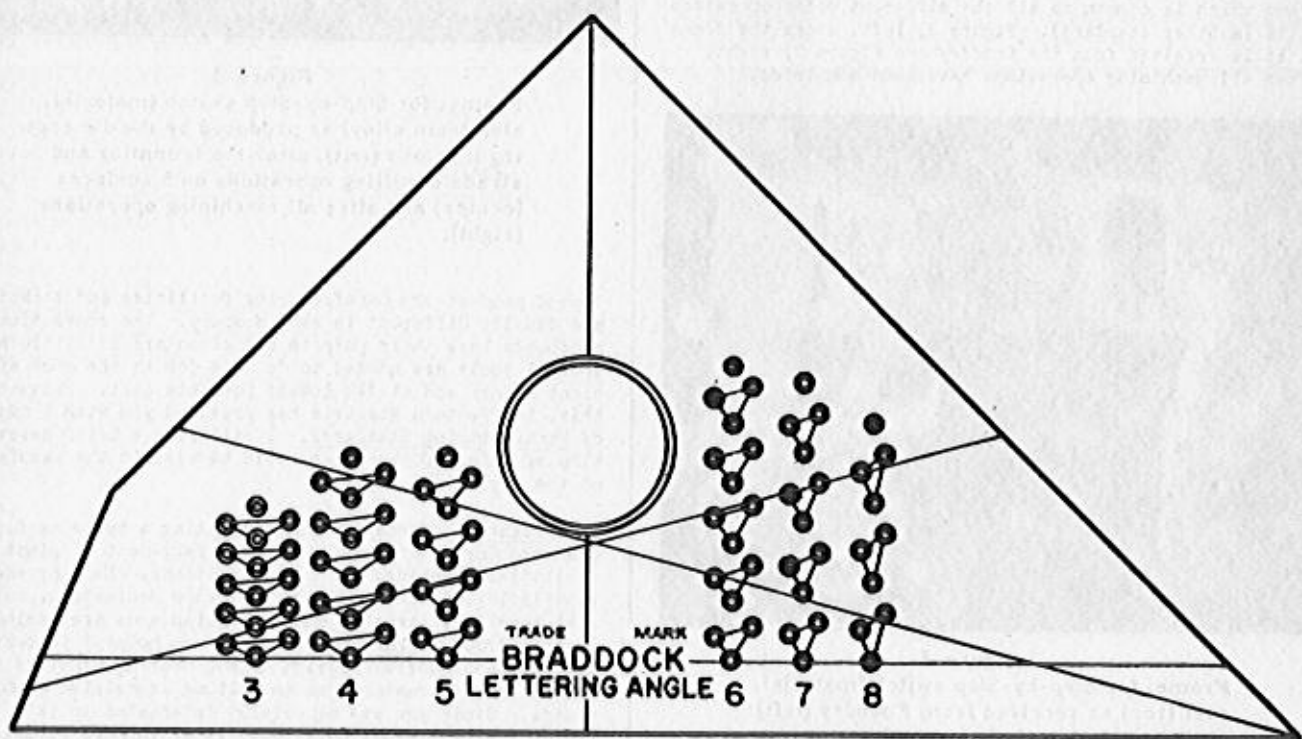

BRADDOCK LETTERING ANGLE—VINYLLITE
STYLE "A" — 5" — 45° SPECIAL CORNER

Our Braddock Lettering Angles are designed to give a quick and easy method of making accurately spaced guide lines for lettering drawings, etc. The simplicity of their application permits the subject to be presented accurately and intelligently. The instrument illustrated above is made specially for several of our large technical schools who use the SPECIAL 67½ degree corner in preference to our regular slotted Angle. The special corner can be made on the 5", 6", 7" and 8"—45. We also manufacture a complete line of Braddock Standard Triangles Vinylite, employing the same high degree of guaranteed accuracy and workmanship as has been maintained through our years of service.

Write to us for Descriptive Circulars.
Your Wholesale Dealer will supply you.

BRADDOCK INSTRUMENT COMPANY

PITTSBURGH 18, PA.

(Continued from page 21)

average number of parts a cutting punch and die will produce between sharpening or repair. The repair time "Out of Service Interval" for the typical punch and die has been standardized. This book is restricted to planning engineers.

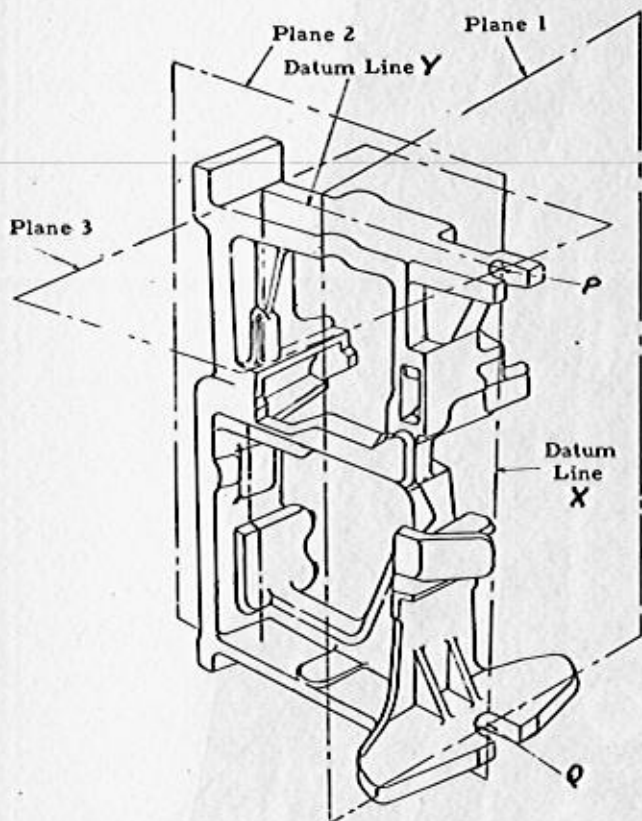

Figure 4
Pictorial view included as a part of the shop drawing of the Step-by-Step switch frame as die cast from aluminum alloy.

our buyers use in purchasing the quality of commercial tool that is required for our business.

Wage Practice Standards guide the engineer and the shop foreman on shop and office occupations, salaries and wages. Safety Clothing and Equipment Standards prescribe such items as goggles and respirators that protect our employees from occupational hazards.

At this time I should like for you to keep a very important fact in mind. Though all of our manufacturing standards are extremely helpful to our engineers and others, they are in no sense a substitute for engineering judgement. They do not do your thinking for you but are essentially guides and references.

Now let us return to the very broad subject of drafting standardization. In a business of our size, we have many different types of drafting and designing work. Time will only permit me to briefly discuss one of these, namely, Apparatus Drafting. This drafting work deals with the manufacture of apparatus and parts used in telephone services. We have over 500,000 active apparatus piece part drawings. The basic design is prepared by the Bell Telephone Laboratories in New York and New Jersey. They furnish engineering or design drawings to the various Western Electric plants. The apparatus drafting in the Manufacturing Division consists of taking these drawings and converting them so that they are suitable for manufacturing purposes. About 20% of this drafting is instrument or line work. The other 80% of the work is of an engineering or analysis nature in connection with new and changed design, of which considerable effort is spent on engineering and shop change orders.

As the Laboratories and Western must keep very close together on apparatus drafting practices, their respective standards organizations have collaborated in preparing suitable drafting standards. Our Apparatus Drafting Standards Book is the result of many years' work. It is published and controlled by the Laboratories and used at all Western plants. Supplementing this book is a manufacturing drafting standard on Western Electric Drafting Routines. These two references make it possible to establish uniform and efficient methods of preparing drawings and change orders for telephone apparatus. Illustrations are used to show preferred methods and short cuts. These two standard books have been of material assistance in reducing drafting costs through reducing drafting time. They also aid in the training of young and new draftsmen.

In the Western apparatus drafting standardization covers far more than the drawing alone. This field includes the four standard books previously mentioned, namely, Apparatus Drafting Standards, Standard Manufacturing Tolerances, Standard Manufacturing Data, and Standard Drafting Routines, and a fifth standard book called General Use Piece Parts. This is a ready reference book containing a complete record of material, size and finish of approximately 12,000 commonly used piece parts mainly in the nature of fastening devices such as screws, nuts, washers, etc. It is widely distributed and aids in procuring parts for use in new apparatus or for substitution in existing apparatus.

While this paper has stressed the value of manufacturing standardization, I should like for you to know that the telephone system must also be highly standardized to give efficient, low cost service. In fact, without standardization we could not operate the 33,400,000 interconnecting Bell telephones now in use.

My Company has used an expanded version of this information in connection with our training program for young engineers. It is hoped that some of these ideas will be of value to you in your college program of training young men to be future engineers.

Material Planning Standards (16,007) help in calculating the amounts of raw materials. It provides material allowance practices and tabulated data on the weight of our materials in different shapes and sizes. This book is likewise restricted to planning engineers. Tool and Gage Design Standards (16,002) give vital data on U.S. design of tools and gages and machine dimensions and clearances that affect tool set-ups. Among other things, it has a special section on Tool Drafting Practices and another important section on Guarding of Punch Press Tools. These two books are used by tool designers, tool makers, tool inspectors and planning engineers.

To make the various parts of our new telephone switch, a number of commercial tools and gages are required. We furnish our buyers, suppliers and shop with Standard Tool Specifications and Standard Ordering Descriptions which are used to procure and inspect the many different types of commercial tools and gages that we use. These standards are based on national standardization practices wherever possible along with studies and tests made within our own plant. We also have a list of Approved Suppliers of Commercial Tools and Gages which

RIEFLER Drawing Instruments

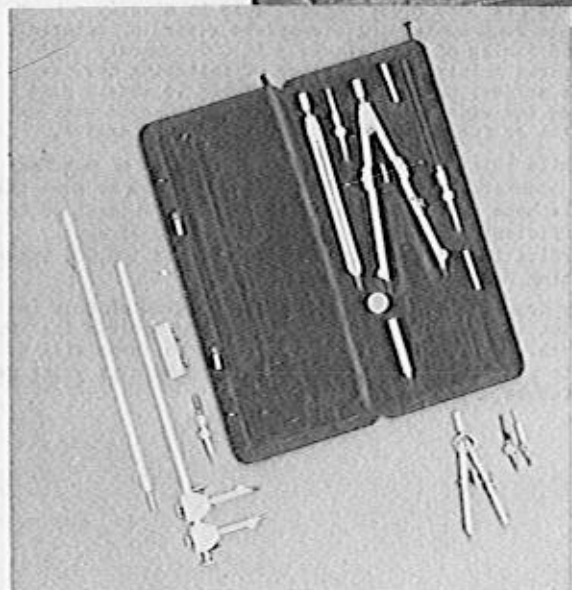
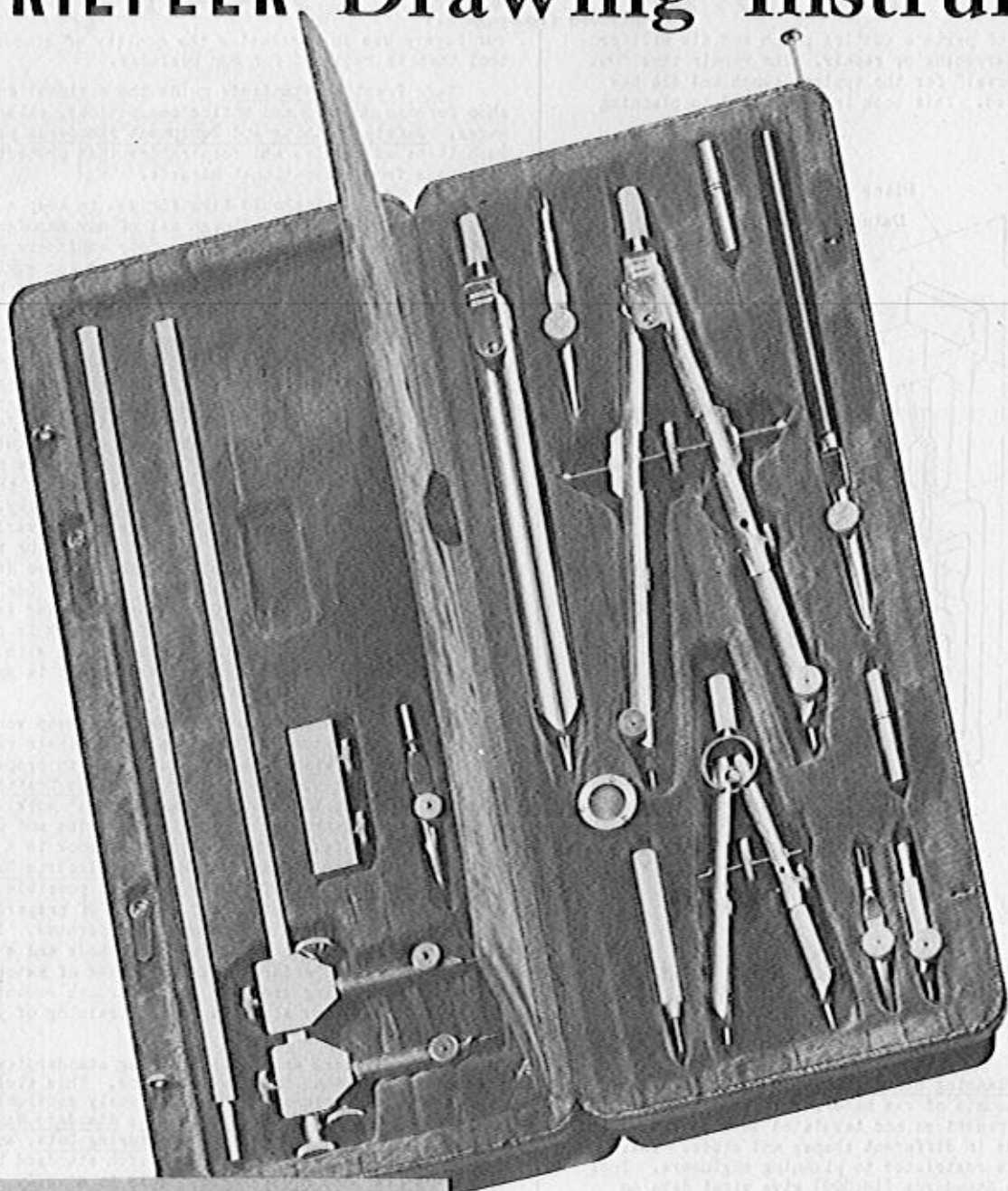

Typical example of the many varieties of the G-Series:

G-1 in double case with spaces provided for addition of beam compass and combination bow.

GRAMERCY

IMPORT COMPANY, Inc.

16 BEAVER STREET • NEW YORK 4, N. Y.

-World Famous *for* Quality

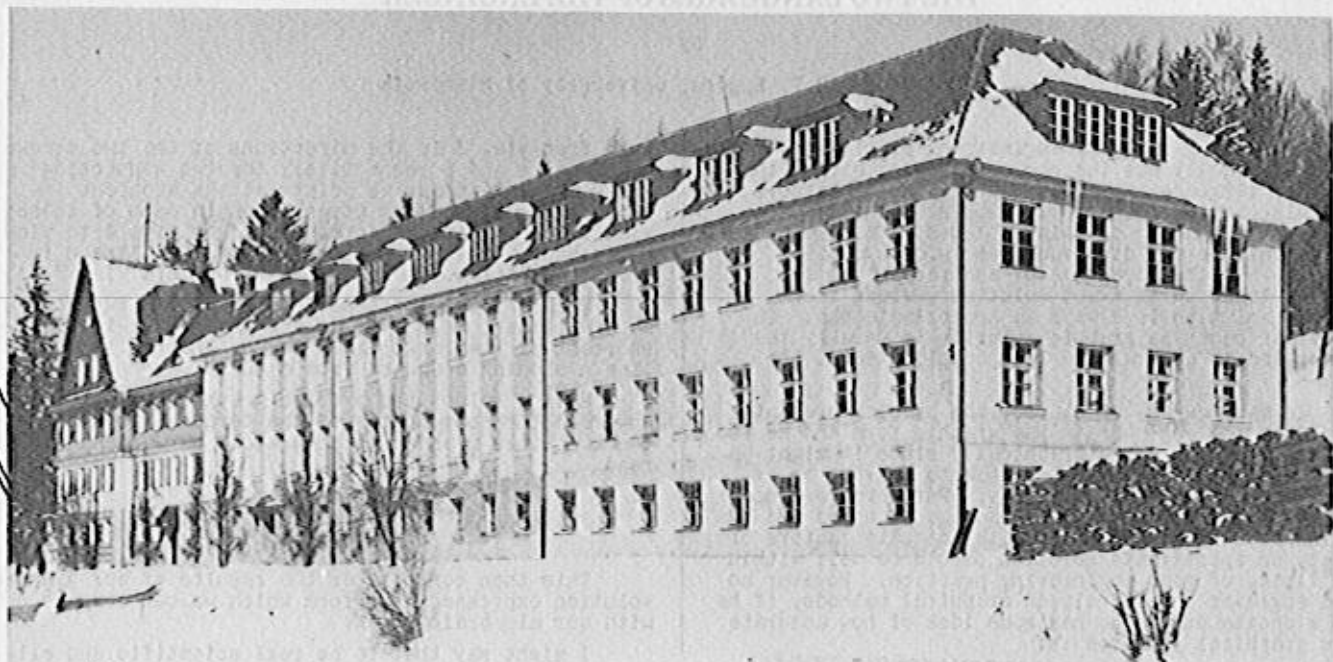

Completely Equipped Factory

Strict Apprenlice Education

Full Staff of Long-Experienced Craftsmen

Constant Rigid Inspection

UNSURPASSED
PRECISION,
THE RESULT OF
RIEFLER'S...



THE TWO LANGUAGES OF THE ENGINEER

by

Professor H.C.T. Eggers, University of Minnesota

In working out many engineering problems the engineer usually has the choice of using either the symbolic language of algebra consisting of letters, numerals, and various other symbols or the graphic language consisting of points, lines, etc. Each has its advantages and disadvantages. The symbolic language has the advantage of accuracy since it usually leads to an exact solution whereas the graphic solution is always an approximate one. On the other hand the graphic solution is usually the faster and in general the less complicated of the two.

In many cases, of course, the problem presents itself to the engineer in the graphic form and he is almost forced to solve graphically since it might be extremely difficult or impossible to convert or express the problem algebraically. Furthermore since the graphic method has the advantage of speed and the engineer is working usually with adequate factors of safety an approximate solution should be well within the limits of good engineering practice. However no good engineer should rely on graphical methods, if he has a choice unless he has some idea of how accurate this graphical solution is.

Those of us who are teaching in the field of graphics have a rare opportunity especially in dealing with many of those space problems encountered in descriptive geometry to have the future engineer put the "acid test" on his solution and let him determine exactly how good the graphic solution is.

To illustrate let us consider the following problem.

Given the two skew lines:

$$q \begin{cases} x - z + 8 = 0 \\ 2x - 5y + 20 = 0 \end{cases}$$

and

$$r \begin{cases} 4x + 3z - 24 = 0 \\ x - y = 0 \end{cases}$$

Required:

The shortest connecting line with a gradient of 20%. Check algebraically.

Note: In mining operations it frequently becomes desirable to locate and construct a connecting horizontal passageway, or, for proper drainage, a nearly horizontal passageway between two adjacent shafts. Due to the high cost of these operations such a passageway should be as short as possible. Such a problem is usually presented to the engineer graphically on a map but it is of such a character that it may easily be adapted to algebraic form and treatment. The problem under discussion here illustrates such a problem.

Graphic Solution:-

Multiple or auxiliary views seem to provide the most convenient way for solving the problem graphically.

In the figure the two given lines q and r are set up in the frontal and horizontal views. The two lines are then projected onto plane 3, so selected that the two lines appear parallel. View 3 is really the key view to the solution. The two arrows near the center of the print indicate the directions of two lines having a gradient of 20%. One of these directions is downward from q to r and the other downward from r to q . Thus since the statement of the problem was not specific on the question of gradient we can expect two solutions. If now we project in-

turn from view 3 in the directions of the two arrows on planes 4 and 5, respectively the two connecting lines m and n appear as points at the apparent intersections of the two given lines in each of these views. Line m is projected back from view 4 to view 3 and hence to views H and F . Similarly line n is projected back to the original views thru view 3.

View 3 shows the true lengths of the two connecting lines. Hence if we are interested in the shortest of these two lines we see that it is the line n sloping downward from q to r .

Having solved the problem graphically we will now read the coordinates of the terminal points of the two lines m and n as accurately as we can. They read

$$\begin{pmatrix} -3.00, 2.80, 5.00 \\ 4.50, 4.45, 2.08 \\ -1.67, 3.33, 6.32 \\ 2.45, 2.45, 4.70 \end{pmatrix}$$

This then constitutes the results of our graphic solution expressed in a form which we can compare with our algebraic check.

I might say that to be real scientific and eliminate the human element as much as possible the graphic solution should be read and recorded before the algebraic solution is calculated.

Algebraic Solution:-

Let the terminals of the connecting line on lines q and r be the points (x_1, y_1, z_1) and (x_2, y_2, z_2) respectively.

The condition that point (x_1, y_1, z_1) be on line q gives the two equations

$$x_1 - z_1 + 8 = 0 \quad (1)$$

$$2x_1 - 5y_1 + 20 = 0 \quad (2)$$

The condition that point (x_2, y_2, z_2) be on line r gives the two equations

$$4x_2 + 3z_2 - 24 = 0 \quad (3)$$

$$x_2 - y_2 = 0 \quad (4)$$

The condition that the gradient be 20% is

$$\frac{y_2 - y_1}{\sqrt{(x_2 - x_1)^2 + (z_2 - z_1)^2}} = 1/5 \quad (5)$$

The condition that the connecting line be the shortest line is

$$D^2 = (x_2 - x_1)^2 + (y_2 - y_1)^2 + (z_2 - z_1)^2 = \text{minimum} \quad (6)$$

Thus we have six simultaneous equations involving six unknowns.

From equations (1) and (2) we can express x_1 and z_1 in terms of y_1

thus

$$x_1 = \frac{5y_1 - 20}{2}$$

$$z_1 = \frac{5y_1 - 4}{2}$$

From equations (3) and (4) we can express x_2 and z_2 in terms of y_2

thus

$$x_2 = y_2$$

$$z_2 = \frac{24 - 4y_2}{3}$$

Reference: THE TWO LANGUAGES OF THE ENGINEER by
Professor H.C.T. Eggers, University of Minnesota

Replace cut in article by the following cut:

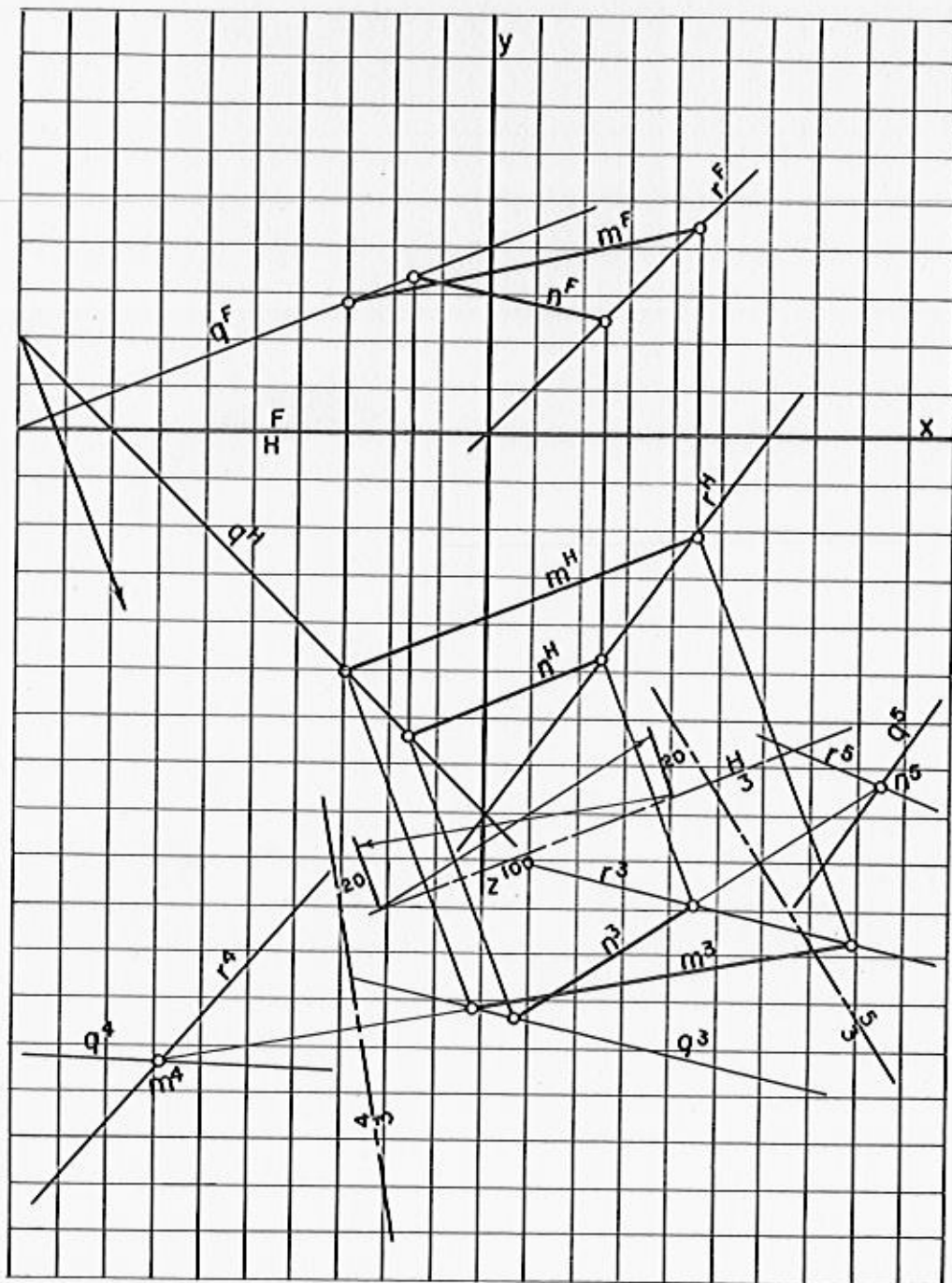

Replace equation $y_1 - y_2 = 0$ in line 16 column 3

by: $y_1 - y_2 \neq 0$

Replace line 16 column 4 which read "Thus an overall measure of the graphic solution is"

by: "Thus an overall measure of the accuracy of the graphic solution."

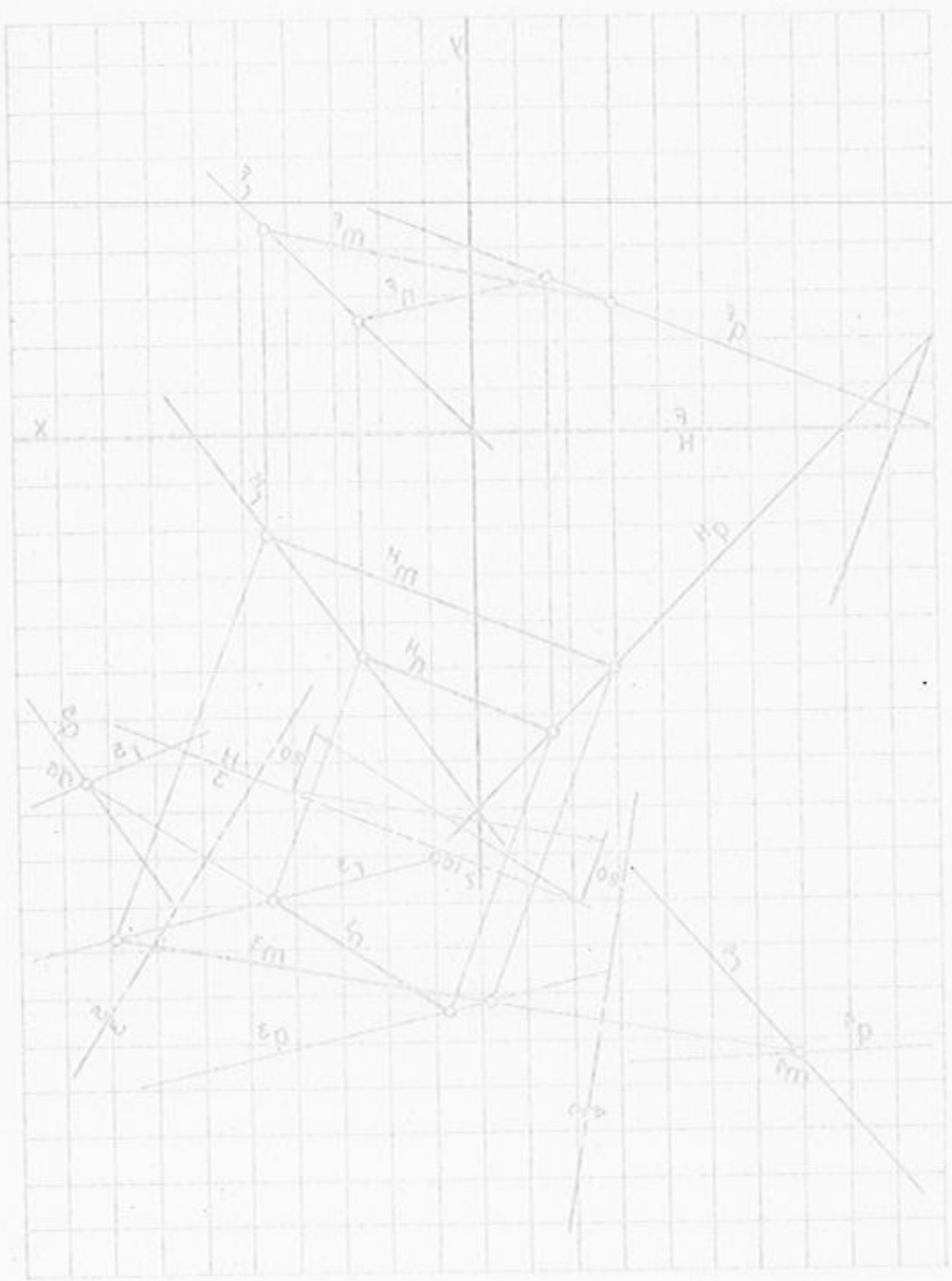

Replace equation $y_1 - y_2 = 0$ in line 16 column 3
 by: $y_1 - y_2 = 0$
 Replace line 16 column 4 which read "Thus an overall measure of the
 graphic solution is"
 by: "Thus an overall measure of the accuracy of the graphic
 solution."

Substituting these values in equations (5) and (6) respectively we obtain the following equations.

$$\phi(y_1 y_2) = 45y_1^2 - 186y_1 y_2 + 80y_2^2 + 360y_1 = 24y_2 - 720 = 0 \quad (7)$$

$$D^2 = F(y_1 y_2) = 243y_1^2 - 6y_1 y_2 + 68y_2^2 - 1800y_1 - 120y_2 + 3600 = \text{minimum} \quad (8)$$

The condition for minimizing equation (8) is

$$\frac{\partial F(y_1 y_2)}{\partial y_1} = \frac{\partial F(y_1 y_2)}{\partial y_2} \quad (9)$$

$$\frac{\partial \phi(y_1 y_2)}{\partial y_1} = \frac{\partial \phi(y_1 y_2)}{\partial y_2}$$

which produces the equation

$$48y_1^2 - 35y_1 y_2 - 13y_2^2 - 192y_1 + 192y_2 = 0$$

which breaks up into two linear factors

thus

$$(y_1 - y_2)(48y_1 + 13y_2 - 192) = 0 \quad (10)$$

By the conditions imposed on the problem namely that the gradient is different from zero, that is

$$y_1 - y_2 \neq 0$$

we obtain

$$48y_1 + 13y_2 - 192 = 0$$

or

$$y_1 = \frac{192 - 13y_2}{48} \quad (11)$$

Substituting this value of y_1 in equation (7) namely

$$\phi(y_1 y_2) = 0$$

we get a quadratic equation in y_2 only, namely

$$307989y_2^2 - 2108160y_2 + 3317760 = 0 \quad (12)$$

Solving we get the two solutions

$$y_2 = 4.39 \text{ and } 2.45$$

Thus working back thru our starting equations we get for our algebraic solution the coordinates of our four terminal points

$$\begin{pmatrix} -2.98, 2.81, 5.03 \\ 4.39, 4.39, 2.15 \\ -1.65, 3.34, 6.35 \\ 2.45, 2.45, 4.73 \end{pmatrix}$$

The differences between the graphic and algebraic solutions are

$$\begin{array}{r} 3.00 - 2.98 = .02 \\ 2.81 - 2.80 = .01 \\ 5.03 - 5.00 = .03 \\ 4.50 - 4.39 = .11 \\ 4.45 - 4.39 = .06 \\ 2.15 - 2.08 = .07 \\ 1.67 - 1.65 = .02 \\ 3.34 - 3.33 = .01 \\ 6.35 - 6.32 = .03 \\ 2.45 - 2.45 = .00 \\ 2.45 - 2.45 = .00 \\ 4.73 - 4.70 = .03 \end{array}$$

$$.39$$

The sum of the correct (algebraic) coordinates are (neglecting sign)

2.98
2.81
5.03
4.39
4.39
2.15
1.65
3.34
6.35
2.45
2.45
4.73
42.72

Thus an overall measure of the graphic solution is

$$\frac{.39}{42.72} \times 100 = .9\%$$

or slightly less than one per cent.

The accuracy here agrees in general with what may be expected when reasonable care is exercised. Thus we see that graphical results compare favorably with those obtained from the slide rule, planimeter, or other approximate method.

It should be pointed out that most algebraic checks do not become quite as long and involved as the one here illustrated which required the solution of six simultaneous equations and the application of a formula (equation 9) from Advanced Calculus. However the problem typifies, in general, the proposition that where a choice is possible the graphic solution is quicker, less involved, and usually quite satisfactory.

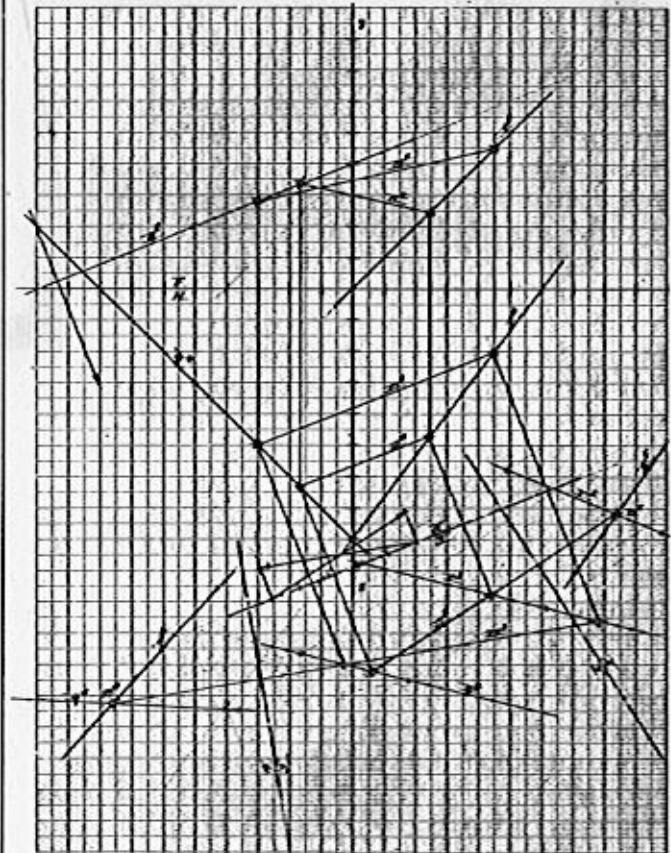

KEUFFEL & ESSER CO.
Est. 1857

NEW YORK

HOBOKEN, N. J.

CHICAGO

ST. LOUIS

DETROIT

SAN FRANCISCO

LOS ANGELES

MONTREAL



Drafting, Reproduction,

Surveying Equipment

and Materials.

Slide Rules,

Measuring Tapes.

(Continued from page 11)

The next week the student begins to study job analysis and how to design problems to accomplish the aims and objectives of his course. The lecture on this subject includes the steps in making a job analysis, and covers the five common types of problems and the various sources of problem material; then gives some details and pointers on designing problems. When the student has a rough idea of what he is going to put into his problem, he is given a chance to peruse a large collection of sample problems.

At this stage, to help the student with his classroom demonstrations and his problem design, we begin to study motivation. Some of the points of view of industrial leaders toward drafting are presented. The common methods of obtaining interest and pointers on maintaining interest are also discussed.

The following week students will study and make instruction sheets and consider course flexibility and provision for individual differences.

Some time is to be spent in studying and discussing how to develop the best attitudes, habits, and ideals in students. Putting the responsibility where it belongs also comes in for its share of attention. Once again a philosophy of education comes to the fore. There would be lectures on classroom management and discipline, plus discussions of the subject. Typical actual problem cases would be offered for solution, or proper handling. The philosophy behind good class management and the objectives of a drafting course are kept in the forefront here.

IV. Teaching Aids.

Falling in naturally with classroom management is the study of equipment and supplies in the drafting room. During the study of equipment, the students are taught how to judge and evaluate a set of instruments, how to run a simple material and supply control, and they learn a little bit about the use, advantages and disadvantages of a half-dozen common reproduction methods.

Following this there is a lecture on the advantages of textbooks; how to select, judge, and use textbooks, workbooks, etc. A very simple basic system for rating textbooks is presented and the relative importance of each phase is discussed briefly. The students are also made aware of how to obtain opportunities for comparison of many of these items at one time.

Throughout the term students would browse through many textbooks, workbooks, visual aids, gadgets, etc., in the performance of the major jobs. Visual aids, principles, and theories would be studied briefly and in some cases visual aids evaluated. The students would be given information concerning about ten sources of movie films, strips, slides, etc. They would receive some information on when and how to use training aids, and why to use them. They would also be given, for their files, a listing of available films, names of magazines in the visual-audio aids field, as well as a listing of many of the available film strips and slides on drafting; and a brief bibliography on visual and audio-education. A summary

of the nature and chief functions of teaching aids would be presented.

Quite a bit on "methods of improving performance" is included in the material students receive. Much of this is presented daily during the term, as "tips" on the bulletin board. A final summary of these is given to the class. As for the rest of it, students read it, then the class discusses when and how to use it.

Parts of two lectures include correlation and coordination. Some of this material is given early enough so that each student would have an opportunity to work correlation into his demonstrations, unit outlines, problems, instruction sheets, etc.

Each term, students make at least one field trip to an industrial concern with the principle emphasis on how to most effectively prepare students for such a trip.

The students would be encouraged to keep a set of manila folders of all material received, collected, and produced during the term. This would be the beginning of a file on drafting, and teaching drafting which the young instructor might use in his own classrooms and offices.

The following is a list of major student activities during the term. Normally, one of these would be completed each week, although some run concurrently with other activities over an extended period of time, and, naturally some of these things are interwoven with each other.

1. Each student works out his own set of objectives for his future use when teaching drafting. This may sometimes be a composite of those found in some of the better sources.
2. The student sets up a course outline and tentative time schedule for a course in the basic fundamentals of drafting.
3. The student designs a unit in drafting, makes up lesson plans, assignments, and later, a test to go with it.
4. He designs a problem or two of a type not too conveniently found in average textbooks or workbooks--one to fit his particular course needs.
5. He designs an individual instruction sheet for specific conditions in order to help provide for course flexibility and individual differences.
6. He conducts before the class at least one of each of the following and participates in discussion and criticism of all of them.
 - a. Blackboard demonstration
 - b. Drafting table demonstration
 - c. Lecture or recitation discussion
7. He contributes some aid to teaching or class management. A project, model, visual aid, etc. (Continued on page 30)

8. He does a little refresher drawing (Part V) to perfect his techniques or explores an essentially new area which his past training has neglected. It would be our hope that he might learn to dig things out for himself, just a little better, because of this.

9. He designs a test covering the unit he worked on earlier, or covering some similar area.

10. He gets a little practical experience in grading drawings by studying old unclaimed elementary and advanced engineering drawings; architectural drawings, and lettering plates. The student studies notations and corrections made by experienced instructors on each type. He assigns a grade evaluation to each drawing (we would compare results later) and makes a study of grading systems and methods of evaluation.

COMMENTS AND NEWS ITEMS

Under the title, "Stature of the Professional Engineer," Dean Clement J. Freund of the University of Detroit in part made the following significant statements:

"It is fair to say that most engineers never think about professional standing. If the question is brought to their attention, they toss it off as unimportant. On the other hand, a very few engineers, probably the best of them, do think, and think hard, about professional standing.

All engineers want to be known as professional men. But are we sure that we know just what a professional man is? What constitutes professional standing? How do we distinguish the engineer who is professional from the engineer who is not professional?

The professional man, in the opinion of authorities, is such to the extent that he is motivated by a desire to serve his fellow men; and an engineer is not professional to the extent that he has no interest in his fellow men.

An engineer may become the world's authority in reinforced concrete or in the metallurgy of alloy steel, or in jet engines, or in the refining of petroleum, or in aerodynamics, but he will never become professional if he has no concern for the well-being of the community.

In my own view, the most important item in the professional engineer's relation to his fellow men is keen sense of right and wrong. The engineer's understanding of science and applied science gives him control over the life and death of his fellows. The atomic bomb is an obvious example. When anybody had that much power over his fellows, it is of tremendous consequence that he shall possess a sensitive moral judgment."

Also from the University of Detroit we received a news item of this heading, "Research Project Completed at U of D."

"A project involving three years of research by 23 people was completed recently, resulting in the compilation of a new set of automotive drafting standards at the University of Detroit.

Announcement was made by Jasper Gerardi, assistant dean of the Engineering College of the University.

'These standards,' said Gerardi, 'will be abridged in booklet form and will be available at minimum cost to Engineering students in January.'

He added that a steering committee of executive engineers and automobile part suppliers worked as researchers to make the project a success."

An old friend of the Drawing Division, Professor William Roever, of Washington University writes, "I have noticed with interest the article entitled, 'Projected Trimetrics,' by Ernest J. Zellmer in the November, 1950 number of the Journal of Engineering Drawing. Concerning this type of projection, I should like to bring to the attention of the readers of the Journal of Engineering Drawing the Theorem of Schwarz and An Introduction to the Theorem of Gauss as given on pp. 26-31 in my monograph entitled, Fundamental Theorems of Orthographic Axonometry And Their Values in Picturization."

The Illinois Institute of Technology is now offering a Technical Drawing Curriculum leading to the degree of Bachelor of Science in Technical Drawing. Their stated objective is to provide a sound foundation in engineering fundamentals and professional education in drafting and methods of teaching. They are to be congratulated for their leadership and foresight. The editor hopes to soon publish a paper setting forth complete details of their program.

To our present knowledge the following engineering drawing staffs have subscribed 100 per cent to the Journal: the University of Minnesota, The Ohio State University, Syracuse University, and the University of Nebraska.

Space requirements have not permitted us to publish in full many of the excellent graphs that were prepared by T. C. Brown on his paper, "A Survey of Supervised Class Hours Required in Graphics Courses", published in this issue.



University Engineering Departments

USE THE

JOHN S. SWIFT CO., Inc. PLANOGRAPH PROCESS

FOR THE REPRODUCTION OF

DRAWING SHEETS



PROBLEM BOOKS



MECHANICAL DRAWINGS



MAPS—CHARTS



INSTRUCTION MATERIAL

Your Choice of Binding: LOOSE-LEAF, SEWED AND CASED, WIRE SPIRAL, PLASTIC, ETC.

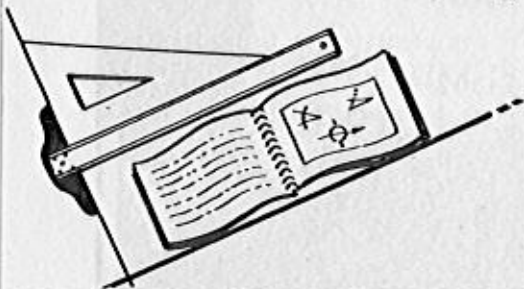

JOHN S. SWIFT CO., Inc.

OPERATING FIVE PLANTS

New York 1, N.Y. 455 West 30th St Lackawanna 4-1144	Chicago 7, Ill. 17 N Loomis St MONroe 7020	St Louis 3, Mo. 2100 Locust St CHEstnut 7141	Cincinnati 2, O. 3rd and Vine Sts PARKway 4148	Cleveland 13, O. 116 St Clair Ave., N.W. FRospect 4488
---	--	--	--	--



**WILD
HEERBRUGG**

*Drawing instruments
of highest accuracy*

The leading Swiss manufacturer of precision instruments introduces an Instrument Set of outstanding merit. Drawing instruments of highest precision and of great accuracy in performance for the most exacting standards.

• Rustproof steel 5 times stronger than brass • Improved straight guidance of the compass-head • Maximum degree of precision is guaranteed • Fine finish of the drawing pens • A modern metal case, not an old-fashioned box.

ASK FOR BOOKLET RZ3006

HENRY WILD SURVEYING INSTRUMENTS SUPPLY CO.
OF AMERICA, INC.

26 COURT STREET, BROOKLYN 2, N. Y. • TRIANGLE 5-0644

(Continued from page 9)

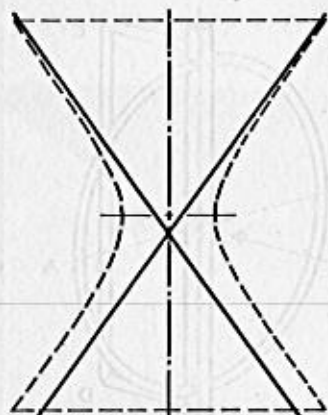

Fig. 4
Hyperboloid generated. Lines of interference intersect below the gorge circle.

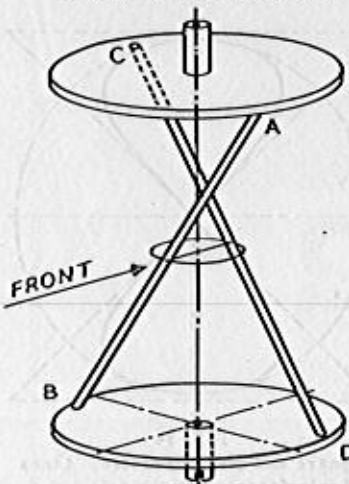
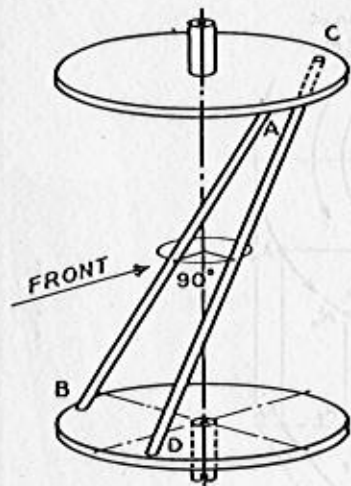

Fig. 5
Rods AB & CD, 180° apart at gorge circle, are for the same generation.



Fig. 6
Hyperboloid generated with line of interference as its axis.



Rods AB & CD, 90° apart at gorge circle, are for the same generation.



Fig. 8
Hyperboloid generated with lines of interference appearing as a hyperbola.

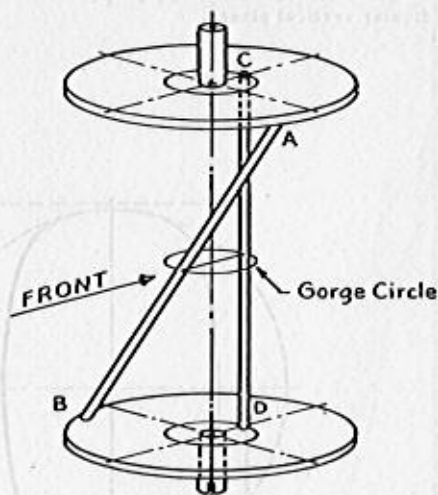

Fig. 9
Rods AB & CD, 180° apart at gorge circle, are generatrices for a hyperboloid and a cylinder.

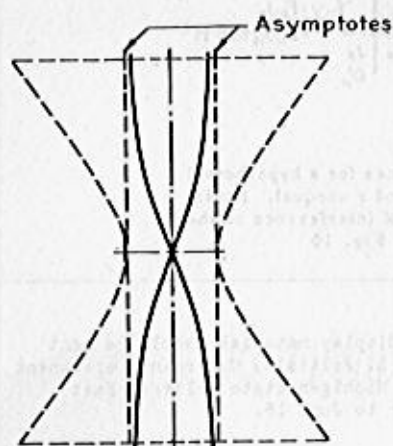

Fig. 10
Outline elements of cylinder are asymptotes of the curved lines of interference.

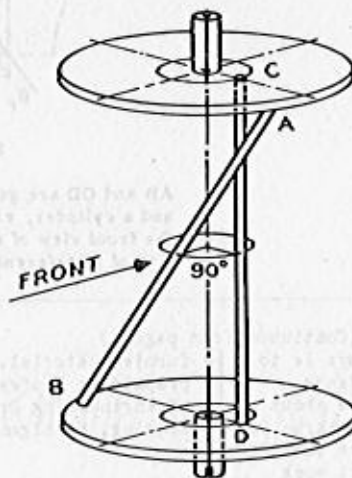

Fig. 11
Rods AB & CD, 90° apart at gorge circle, are generatrices for a hyperboloid and a cylinder.

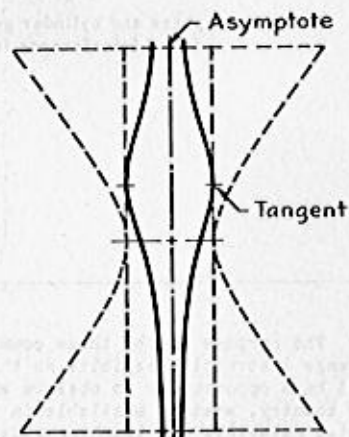

Fig. 12
The axis appears to be the asymptote of the curved lines of interference.

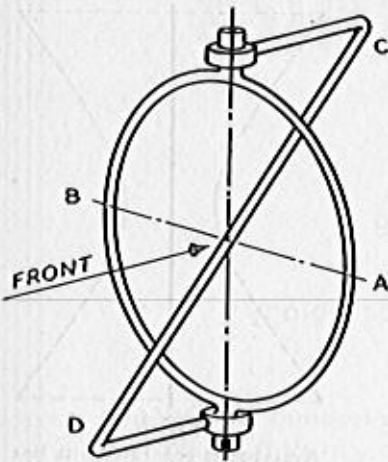

Fig. 13
Ring and rod CD in mutually perpendicular vertical planes.

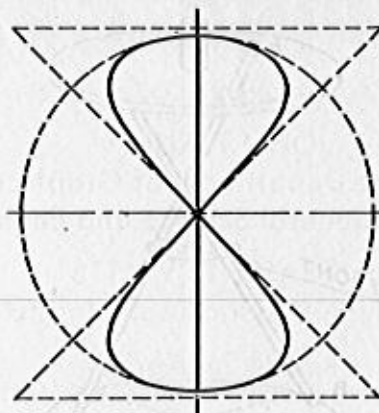

Fig. 14
Sphere and cone generated. Lines of interference are the axis and a "figure 8".

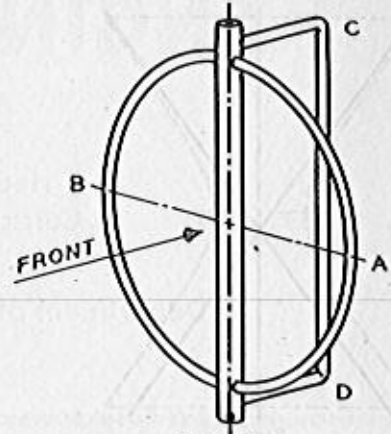

Fig. 15
Ring and rod CD in perpendicular planes which intersect along axis.

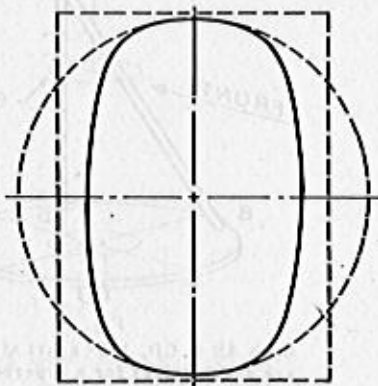

Fig. 16
Sphere and cylinder generated. Line of interference is an oval.

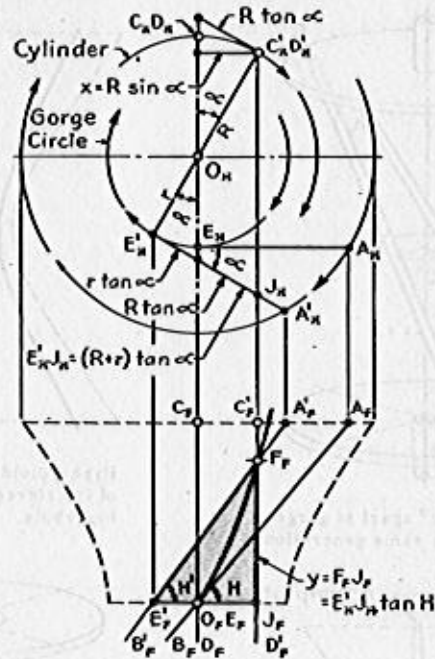

Fig. 17

AB and CD are generatrices for a hyperboloid and a cylinder, radii R and r unequal. F_f is the front view of a point of interference on the line of interference. See Fig. 10.

(Continued from page 6)

The purpose of the three committees on displays is to arrange instructive exhibits so that all in attendance will have opportunity to observe what is being done about the country, what is available in way of various instruments, materials and teaching aids. It is the hope that each school will be represented not only in student work but will cooperate with the other committees in furnishing interesting display material. Please get in touch with these committee chairmen regarding your willingness to

furnish material. All display material should be sent prepaid to Professor C. L. Brittain, Chairman, Department of Engineering Drawing, Michigan State College, East Lansing, Michigan, prior to June 15.

Be sure to arrange to attend this meeting. An invitation is extended to all interested in addition to our own Division members.

ENGINEERING GRAPHICS

by

JOHN T. RULE

Head of the Department of Graphics and
Curricula of General Science and Engineering

and EARLE F. WATTS

Department of Graphics, Massachusetts Institute of Technology

Ready in April

Designed as a basic course in Engineering Graphics, this book attempts to bring together and coordinate graphical processes of value to the engineer. Its aim is to survey the field in a manner that will point up for the student the power of graphical methods and give him the "graphical state of mind" so that he will weigh the value of a graphical solution against those of an algebraic solution in any problem he may meet. The book is basically fundamental theory supplemented by illuminating practical applications.

Contents

I. THE STRAIGHT LINE AND CIRCLE: A. Brief History of Constructive Geometry. The Tools of the Geometer—Classical Constructions. B. Drafting Tools—Pencils, Boards and T Squares, Triangles, Dividers, Compasses. C. Precision in Drafting. Accuracy in: Lines, Parallel Lines, Angles, Scales, Cumulative Errors, Shrinkage. D. Elementary Constructions. Simple Euclidean and Practical Constructions. E. Approximate Constructions. Length of Arcs. Use of Templates. F. Graphical Arithmetic. Addition. Subtraction. Multiplication. Division. Mean Proportional. Square Root. Graphical Algebra.

II. THE CONSTRUCTION OF CONIC SECTIONS: Historical. Sections of a Cone. Ellipse. Parabola. Hyperbola. Circles of Curvature. Diameters and Chords of Conics. Axes and Foci. Eccentricity.

III. PROJECTIVE CONSTRUCTIONS: Projective Geometry. Elements of Infinity. The Point and Line at Infinity. The Infinite Circle. Dividing a Line into Segments. Cross Ratio. Pencils of Lines. Map Nets. Desargue's Theorem. Projective Properties of Conics. Conics by Intersecting Pencils. Pascal's Theorem—Line Conics. Brianchon's Theorem. Fair Curves.

IV. ROULETTES AND SPIRALS: Cycloid. Epicycloid. Hypocycloid. Trochoid. Envelope Roulette. Catenary. Involute. Glissettes. Archimedean Spiral. Logarithmic Spiral.

V. VECTOR GEOMETRY: Scalars and Vectors. Composition and Resolution of Vectors. Funicular Polygon. Relative Motion.

VI. GRAPHICAL SCALES: Scales Defined. Scale Modulus. Adjacent Scales. Sliding Scales. Perpendicular Scales. Rectangular Coordinates. Perpendicular Uniform Scales. Scale Transformation. Perpendicular Logarithmic Scales. Logarithmic Graph Papers. Scales for Exponential Equations Representing Three Variables. Parallel Scale Align-

ment Charts. Nomography.

VII. EMPIRICAL CURVES: Graphs of Engineering Data. Engineering Curves. Straight Lines in Rectangular Coordinates. The Direct Plot. Constants of a Straight Line. The Power Law. Power Curves. The Straight Line on Logarithmic Paper. Determining Constants of Power Curves. Extending a Logarithmic Graph. The Exponential Equation. Exponential Curves. Semilogarithmic Graphs. Determining Constants of Exponential Curves. The Logarithmic Curve. Natural Logarithms. General Procedure for Data of Unknown Form.

VIII. PERIODIC CURVES: Harmonic Law. Sinusoid. Harmonic Motion. Composition of Harmonic Curves. Fourier Series. Harmonic Analysis.

IX. GRAPHICAL CALCULUS: Derived Curves. The Area Law. Graphical Integration. Ray Polygon Method. Use of Integral Curves. The Slope Law. Use of Derivative Curves. Graphical Differentiation. Families of Curves. Numerical Integration. The Formal Calculus.

X. THE GEOMETRY OF PROJECTION DRAWING: Orthographic Drawing. Principal Views. Visualization. Sketching in Orthographic Projection. Pictorial Sketching. Projection. Correspondence. Quadrants. Mongean System. Basic Theorems and Constructions of Orthographic Projection. The Three View System. Series of Views. Fundamental Views of a Line. Views in Specified Directions. Fundamental Views of a Plane. Plane Constructions on Oblique Planes. Rotation.

XI. PICTORIAL PROJECTION: Axonometric Projection. Isometric. Isometric Circles. Oblique. Dimetric and Trimetric.

XII. CONVENTIONS OF PRACTICAL DRAFTING: Sections. Threads. Dimensioning. Detail Drawings. Engineering Standards.

Send for a copy on approval

McGRAW-HILL BOOK COMPANY, Inc.

330 WEST 42ND STREET

NEW YORK 18, N. Y.

VAN NOSTRAND FOR COLLEGE TEXTS



Have You Examined The NEW 3rd Edition Of
SMUTZ and GINGRICH'S

DESCRIPTIVE GEOMETRY

By FLOYD A. SMUTZ and RANDOLPH F. GINGRICH

Both of Kansas State College of Agriculture and Applied Science

- Designed for students of the freshmen and sophomore level as an integral part of their training in engineering drawing.
- Definitions, notations and nomenclature are in accord with the recommendations of a standards committee of the Drawing Division of the American Society for Engineering Education.
- Entire book rewritten in clear and simple language, with problems rearranged in a more logical sequence.
- New cuts have been made for all illustrations.
- New problems have been added to replace those found to be of little value.
- Application problems are designed for 8 1/2 x 11 inch drawing paper and are worded to direct the attention of engineering students to the usefulness of descriptive geometry in their training program.
- All solutions are made by methods used in engineering drafting rooms.
- Definitions of words that may be new to the student are contained in a glossary for handy reference.

CONTENTS: I. Introduction; II. Projection of a Point; III. Auxiliary Projections of Lines; IV. Auxiliary Projections of Planes; V. Revolution Method; VI. Non-Intersecting Lines; VII. Surfaces; VIII. Tangents to Surfaces; IX. Intersecting Surfaces; X. Applications to Shades and Shadows; XI. Glossary.

142 pp. _____ 7 x 10 _____ Cloth _____ Illustrated _____ \$3.00

ENGINEERING DESCRIPTIVE GEOMETRY by Charles Elmer Rowe

More than 1000 problems furnish excellent practice for the student in this text which gives very detailed attention to shades, shadows and perspective. Particular emphasis is placed upon orientation which aids the student in developing powers of visualization. The text follows the direct method which the author believes makes the subject more interesting.

299 pp. _____ 6 x 9 _____ Cloth _____ Illustrated _____ \$3.50

TECHNICAL DESCRIPTIVE GEOMETRY by William E. Street

A new approach to the subject is used in this text which develops the draftsman's method of treatment in obtaining size, shape and position of every detail of structures and machines. Illustrations and problems are arranged in progressive order depending upon the method of solution.

179 pp. _____ 7 x 10 _____ Cloth _____ Illustrated _____ \$3.00

If You Teach or Direct These Courses, EXAMINATION COPIES Are Available for You Upon Request.



D. VAN NOSTRAND COMPANY, INC.

PUBLISHERS SINCE 1848

250 FOURTH AVENUE

NEW YORK 3, NEW YORK