

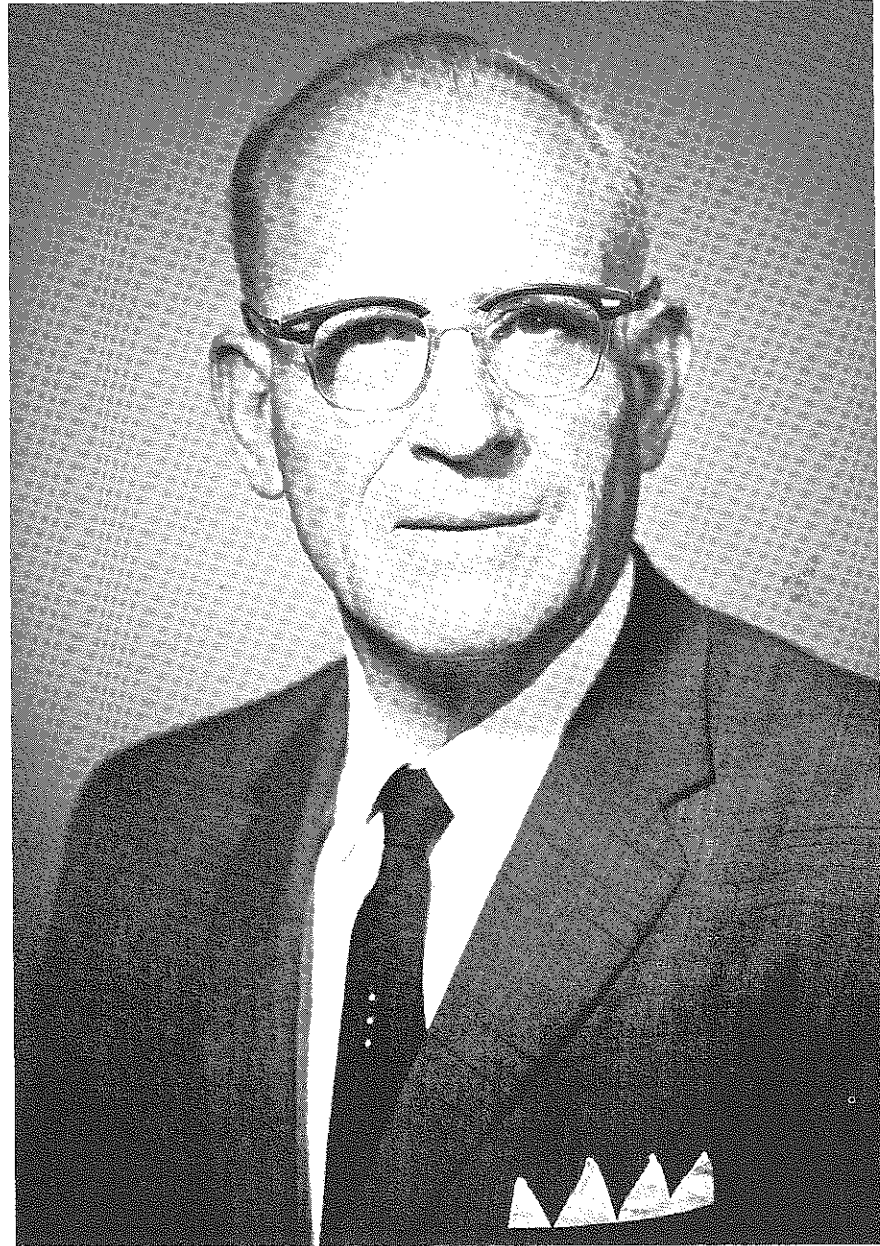

ENGINEERING GRAPHICS  
WINTER 1969  
VOLUME 33  
NUMBER 1  
SERIES 98



William E. Street





# The Journal of Engineering Graphics

## EDITOR

Borah L. Kreimer  
 Northeastern University  
 Suburban Campus  
 South Bedford Road  
 Burlington, Massachusetts  
 01803

## ASSOCIATE EDITOR

Ernesto Blanco  
 Tufts University  
 Medford, Massachusetts  
 02155

## ASSISTANT EDITORS

William S. Chalk  
 University of Washington  
 Seattle, Washington  
 98105

Herbert W. Yankee  
 Worcester Polytechnic Institute  
 Worcester, Massachusetts  
 01609

## TREASURER & CIRCULATION MANAGER

Wilfred P. Rule  
 Northeastern University  
 Room 400DG  
 Boston, Massachusetts  
 02115

## ADVERTISING MANAGER

Kenneth E. Botkin  
 Purdue University  
 MGEL 104A  
 W. Lafayette, Indiana  
 47907

Published for teachers and others interested in Engineering Graphics. It is published three times per year -- Fall, Winter, and Spring. The subscription rates are: \$2.00 per year in the United States (single copies 75¢). Foreign rates upon request.

Published by the Division of Engineering Graphics, ASEE  
 WINTER 1969 VOLUME 33 NUMBER 1 SERIES 98

The views expressed by the individual authors do not necessarily reflect the editorial policy of the JOURNAL OF ENGINEERING GRAPHICS or the Division of Engineering Graphics of ASEE. The editors make reasonable effort to verify the technical correctness of the material published; however, final responsibility rests entirely with the individual authors.

## CONTENTS

ARTICLES	Page
TEACHING THE DESIGN PROCESS IN THE FRESHMAN YEAR - Ralph M. Coleman	21
USING THE TEAM APPROACH IN TEACHING ENGINEERING GRAPHICS AND DESIGN - Earl D. Black	28
COMPUTER PRODUCED NOMOGRAPHS - Edward V. Mochel	37
WHAT A SCIENTIFIC COMPUTER CENTER CAN DO FOR THE ENGINEER - J. B. Vail and J. R. Sandlin	42
A VECTOR ANALYSIS APPLICATION TO GRAPHICS - Fryderyc E. Gorczyka	49
AN EASY GRAPHICAL METHOD FOR FINDING THE RESULTANT OF ANY TWO FORCES - Pedro Ramon Moliner	52
A COMPARATIVE STUDY OF METRIC AND UNIFIED (U. S.) FASTENERS - Robert Shaffer and Charles J. Baer	56
<b>FEATURES</b>	
EDITOR'S BOARD	3
IN THE DIVISION	
PROFESSOR HIGBEE	5
EDUC. REL. COM. REPORT	6
MID -YEAR MEETING, 1969	8
ASEE ANNUAL MEETING	10
TEACH. TECHNIQUES COM. REPORT	13
BIBLIOGRAPHY COMMITTEE REPORT	14



New from  
Addison  
Wesley

## ENGINEERING DESIGN GRAPHICS

By JAMES H. EARLE  
*Texas A & M University*

This text is designed as an introduction to engineering design through the application of descriptive geometry and graphical principles at the freshman level. Content is structured to guide the student through the design process from problem identification to the design and analysis of his solution, including team dynamics, gathering data, human engineering, patents, technical reports, oral presentation and final implementation. The design process is emphasized through numerous industrial examples, illustrations and photographs using graphical methods as a primary tool of design and analysis. Principles are developed in sequential steps printed in two colors utilizing programmed instruction techniques. Material is available for courses varying in length from one semester to three semesters. The text is suitable for both technology and engineering programs.

*In press (1969)*

## DESIGN and DESCRIPTIVE GEOMETRY PROBLEMS 1, 2, and 3

By J. H. EARLE, S. M. CLELAND, J. P. OLIVER,  
L. E. STARK, P. M. MASON, N. B. BARDELL,  
R. F. VOGEL, and M. P. GUERARD  
*Texas A & M University*

- 1: 60 problems, *paperbound* \$3.95.
- 2: 69 problems, *paperbound* \$3.95.
- 3: *In press, paperbound* (1969).

These are the first three in a planned series of annual versions of a problem book providing a semester's work in descriptive geometry as taught in engineering graphics programs. Each version is composed of entirely different problems. This is designed to provide

fresh sets of up-to-date assignments, and to eventually produce a large source of unduplicated problems.

The contents are designed to introduce the student to the engineering design process through a series of engineering problems that are solved with descriptive geometry. The books clearly develop the relationship of abstract principles to a variety of concrete problems which are illustrated by photographs and drawings. By this combination of theory and practical application, the student is introduced to engineering, creativity, and design.

*Teacher's Guides and Solutions Manuals*

## ENGINEERING GRAPHICS and DESIGN PROBLEMS 1, 2, and 3

By J. H. EARLE, S. M. CLELAND, J. P. OLIVER,  
L. E. STARK, P. M. MASON, N. B. BARDELL,  
R. F. VOGEL, and M. P. GUERARD  
*Texas A & M University*

- 1: 68 problems, *paperbound* (1967).
- 2: 79 problems, *paperbound* (1968).
- 3: *In press, paperbound* (1969).

These are the first three in an annual series of new versions of a problem book designed to provide fresh and up-to-date sets of unduplicated problems.

Intended for freshman-level college courses in engineering graphics, the books introduce students to engineering, communications, and design. Content areas include the use of instruments, geometric construction, graphical trigonometry, graphs, sketching, orthographic projection, auxiliaries, sections, fasteners, pictorials, design problems, and engineering analysis. The books provide a large number of actual industrial examples, most of which are illustrated by photographs or industrial drawings.

*Teacher's Guides and Solutions Manuals*

---

Write for approval copies

---

**Addison-Wesley**  
PUBLISHING COMPANY, INC.  
Reading, Massachusetts 01867



THE SIGN OF  
EXCELLENCE



# Editors' Board

## A LOOK BEYOND



A Guest Editorial  
by  
Klaus Kroner  
University of Massachusetts

Most of our profession have, over the past decade or so, been very much concerned with modernizing Graphics course contents. In some instances, Graphics teachers were alert to the changing times and initiated introduction of challenging and motivating topics themselves, while in other cases changes were brought about by pressure from the degree granting departments or deans.

Thus, at the expense of drafting skills and rote exercises, we have, to varying degrees, introduced our students to such topics as Graphical Calculations, Nomography, and, at last, open-ended Design Problems in the Freshman courses; and at most institutions, this is being accomplished in fewer contact hours than were available when the "traditional" Graphics courses were being taught.

It took time to convince many teachers that the introduction of Design at the Freshman level is not only desirable from the Engineering Education point of view, but is actually possible in spite of the students' lack of sophistication in the fields of mathematics, materials, mechanics, etc. Now there is considerable evidence -- as manifested by the large number of entries in the Design Competition at the 1968 Annual Meeting -- that Creative Design has become a major topic in the Graphics courses of many engineering schools. There is no doubt that the 1967 Summer School, sponsored by the Division, was the influencing factor which brought this about. The question that now comes to mind: What next? Is the Design approach the ultimate in Graphics Education? I don't believe this is so. The Engineering World is not going to stand still; hence, curricula will and must continue to be dynamic and alert to the need of the profession.

Before speculating too much about the future, I would like to suggest a pause in this

relentless drive. We have been so intent on making our semester - to - semester course changes, lest we fall behind in our race towards the "Goals" which have been set for us, that no time has been taken to look about us and take in the overall vista that surrounds us. What, for example is being done in our vocation, in other countries? It is difficult to imagine that Graphics is a static field elsewhere, while undergoing continuous change here at home. Yet one finds little evidence in our professional literature of any organized effort to study foreign curricula in the field of Graphics. Are we so egotistical that we think nothing can be learned from our brethren abroad? Surely there must be valuable experiences, ideas, and suggestions to be gained from better communication with our associates across the oceans. Should a publication similar to the JOURNAL OF ENGINEERING GRAPHICS exist in a foreign country, perhaps a subscription exchange can be arranged; then our editor and his staff would be made aware of noteworthy papers written overseas. Undoubtedly, valuable articles and books have been written abroad which should be brought to our attention, translated, if necessary, and published in appropriate form in this country.

An attempt at organizing an International Conference was underway, a few years ago, mostly at the urging of Professor Steve Slaby of Princeton University, but unfortunately this never developed because of funds. Would it not, however, be a fruitful endeavor to urge a few Division members to visit Engineering Schools and Technical Institutes in other countries? Through interviews with faculty members and by observation information could be gathered on unique teaching methods, innovations, subject matter, and the whole approach to Graphics Education. Subsequently, our emissaries could be asked to report their findings at meetings and/or through articles in the JOURNAL.  
(continued on page 25)

# BRADDOCK LETTERING ANGLES

VERSATILE LETTERING TRIANGLES FOR

SYSTEMATIC  
DIMENSIONING  
UNIFORM  
LETTERING

ACCURATE  
SPACING  
PRECISE  
DRAWING

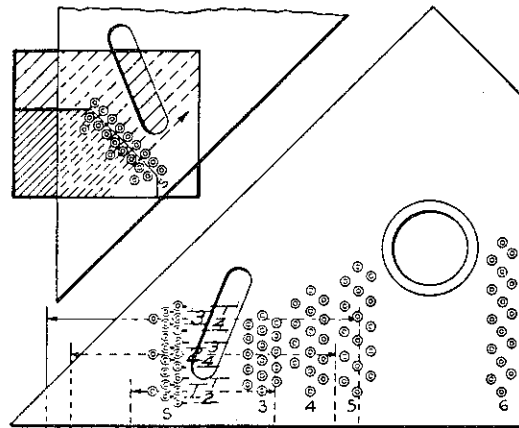

Style "A"

- 5"-60
- 6"-60
- 7"-60
- 8"-60
- 9"-60
- 4"-45
- 5"-45
- 6"-45
- 7"-45
- 8"-45
- 6"-45 Brd.-Rowe
- 8"-45 Style "C"

Style "B"

- 5"-60
- 6"-60
- 7"-60
- 8"-60
- 9"-60
- 4"-45
- 5"-45
- 6"-45
- 7"-45
- 8"-45
- 6"-45 Brd.-Rowe
- Lettering Device

SYSTEMATIC DIMENSIONING

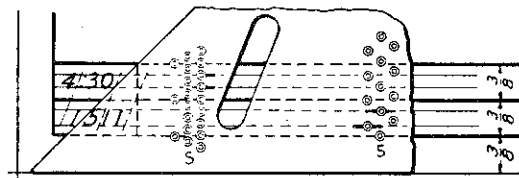

LAYING OUT TITLE STRIP

8"-45 Style "B" Brd.-Rowe

Our Braddock Lettering Angles are designed to give a quick and easy method of making accurately spaced guide lines for lettering drawings, etc. The simplicity of their application permits the subject to be presented accurately and intelligently.

## BRADDOCK INSTRUMENT COMPANY

PITTSBURGH, PA. 15104

# IN THE DIVISION



Professor Emeritus Frederic G. Higbee, head of Engineering Drawing at the University of Iowa from 1905 until 1951, died on Tuesday December 3, 1968 at Mercy Hospital in Iowa City. Professor Higbee, 87, had been admitted to the hospital on November 14 with emphysema.

Funeral services were held at the Beckman-Butherus Funeral home in Iowa City.

The recipient of numerous awards and honors, Professor Higbee was the author of six books and was listed as an authority on descriptive geometry and engineering drawing in "Who's Who in America," "Who's Who in Engineering" and "Who Knows and What."

In 1950 he received the Division of Engineering Graphics' first Distinguished Service Award for his outstanding contributions in the field of graphics.

Born in Fremont, Ohio, Professor Higbee attended Kenyon Military Academy and the Case School of Applied Science in Cleveland. He received his B. S. degree from Case in 1903 and served as an assistant engineer with the Osborn Engineering Company of Cleveland during the following year.

After a year as an instructor at Case, he became assistant professor and head of Engineering Drawing at the University of Iowa in 1905.

In 1908 he received an M. E. degree from Case, and in 1909 he was promoted to Professor of Engineering Drawing at the U of I.

In 1912 he married the former Beth Mather of West Branch, Iowa.

Aside from his duties in the Engineering Drawing Department, Professor Higbee served from 1926 to 1951 as director of convocations at the University of Iowa. He also served as a member of the Athletic Board and the Transit Board, and as chairman of the Campus Planning Committee he evolved in large part the general campus plan of the University.

In the early 1930's he was the secretary of the U of I Alumni Association. He was an active member of the Engineering Drawing Division of A. S. E. E. and was the first editor of the JOURNAL OF ENGINEERING DRAWING.

Before retiring, after 47 years of service at the U of I in 1952, Professor Higbee had also served as acting dean of the College of Engineering for one year.

Active in community affairs, he was a pioneer member and first chairman of the Iowa City Zoning Commission in 1924-25, and later became chairman of the Iowa City Board of Adjustment.

As chairman of the Iowa City Engineers Club committee which stressed the value of good engineering practices in road construction, he led a public speaking campaign to promote the authorization of a bond issue for road construction in Johnson County. As a member of the Red Cross Board in the early 1920's, when annual drownings occurred in the Iowa River,

Professor Higbee originated a city river patrol system.

In 1952 he was awarded the Iowa City Engineers Club Distinguished Service Award for "contributing his time, energy and professional skill to the development of a greater Iowa City."

His survivors include his wife and two sons, Frederic Goodson Jr. of Media, Pennsylvania, and Jay Anders of Seattle, Washington as well as seven grandchildren and two great grandchildren.

ENGINEERING GRAPHICS IN THE TWO YEAR COLLEGE  
A Report Of The  
EDUCATIONAL RELATIONS COMMITTEE

Three years ago the Educational Relations Committee of the Engineering Graphics Division presented a report regarding Engineering Graphics education in secondary schools.\* Included in that report were recommendations for a typical high school Graphics course outline, listing individual topics and the amount of time that should be devoted to them. The necessity for rapport between college and high school teachers was also emphasized.

Since then the E.R.C. has turned its attention to the junior and community colleges and the two-year technical institutes to see how the Division could assist in the development of first-class Graphics curricula at that level. It was decided to investigate first the present state of Graphics education in those schools. To this end the committee prepared a questionnaire which sought to determine the nature of the typical Engineering Drawing course. Last spring copies of this form were sent to limited number of two-year institutions, and subsequently 41 replies were received. This is, admittedly, a rather small number from which to derive statistically useful information, nor was the sample geographically well distributed (18 of the replies came from one state). Perhaps, however, some general conclusions can be derived from the data at hand.

In the tabulations shown, only those schools which indicated that they had technical-oriented programs from which students could transfer to engineering colleges, were taken into consideration. The questionnaire provided a place where the types of technical curricula could be checked. To the question relating to their schedule, only three said they operated on the quarter system, none are on a trimester plan and all others work on a semester schedule.

From Table A one discovers that a majority of the responding schools is municipally operated, and that Civil, Electrical, Industrial and Mechanical Engineering curricula are fairly evenly represented in this sample.

individual schools ranged from none to ten. The breakdown of individual topics within their "basic" drawing courses is shown in Table B. For a first course, the coverage would appear to be adequate with one notable exception -- design. Only two of the schools indicated inclusion of creative design in their course outline. The time spent on teaching the use of instruments seems rather excessive for a college-level course. Even in the high school course less than two percent of the total course time was recommended for this topic.

It is interesting to compare the percentage of exposure time for the principal subjects as reported by the two-year institutions with the percentages recommended by the E.R.C. for secondary schools. Orthographic projection, dimensioning and working drawings were ranked

TABLE A  
Selected Responding Institutions, Their Affiliations, and Selected Programs Offered.\*

College	Affiliation			Programs				Others
	State	Municipal	Private	Agr.	Civil	Elect.	Ind. Mech. Chem.	
<b>ILLINOIS</b>								
1. Chicago City C.		x					x	Automotive Air Condition, Horticulture
<b>MASSACHUSETTS</b>								
1. Bristol C. C.			x					General
2. Greenfield C. C.	x				x			
<b>MICHIGAN</b>								
1. Alpena C. C.		x			x	x	x	
2. Lake Michigan C.		x			x	x	x	Pre-Engin.
3. Lake Superior S. C.	x				x	x	x	Geological, Mining, Geophysical, Metallurgical
4. Southwestern Mich.	x				x	x	x	
<b>MISSOURI</b>								
1. Crowder College		x			x	x		
2. Florissant Valley CC		x			x	x	x	
3. Meramec C. C.		x			x	x		Arch. Drafting Tech. Illus. Architectural
4. Metropolitan J. C.					x	x	x	
5. Mineral Area C.		x			x	x	x	
6. Missouri West C.		x			x	x	x	
<b>NEW JERSEY</b>								
1. Mercer County C.C.		x			x	x	x	
2. Middlesex County C.		x						Engineering Science
3. Ocean County C.	x				x	x		
4. Union College			x		x	x	x	
<b>NORTH DAKOTA</b>								
1. Lake Region J. C.			x		x			Drafting
2. State School of Science	x							Pre-Engineering
<b>TEXAS</b>								
1. Alvin J. C.	x				x	x	x	
2. Amarillo College	x				x	x	x	Data Proc., Drafting
3. Central Texas C.	x				x	x	x	
4. Del Mar College		x						
5. El Centro College					x	x	x	
6. Howard County J. C.					x	x	x	
7. Kilgore J. C.		x			x	x	x	
8. Navarre J. C.	x				x	x	x	Aerospace
9. Odessa J. C.	x				x	x	x	Data Proc., Drafting
10. Paris Junior C.		x			x			
11. St. Philip's C.		x						
12. San Antonio C.		x			x			Pre-Engineering
13. San Jacinto C.	x				x			
14. South Plains C.	x				x	x	x	
15. Texarkana College	x				x	x	x	
16. Weatherford C.		x						Drafting
TOTAL	13	21	1	11	22	21	21	4

\*Only those listed from which students can transfer to 4-year engineering curricula.

The list of graphics-related courses at the

identically in both instances and the difference of actual percentages is remarkably small between the two. The comparison of these and other major topics is included in Table B.

TABLE B

Percentage of Course Contact Hours

Topic	2-Year College Survey	High School Course Recommendation
1. Orthographic Projection	17.6	14.5
2. Dimensioning	10.3	9.4
3. Detail & Assembly Drawings	10.1	9.4
4. Applied Geometry	8.3	6.1
5. Sections	7.7	7.8
6. Sketching	7.0	8.3
7. Isometric	6.5	7.2
8. Oblique	5.0	5.6
9. Developments	4.8	---
10. Instruments	4.4	1.7
11. Auxiliary Views	3.8	8.3
12. Perspective	2.6	---
13. Threads & Fasteners	2.2	5.6
14. Electrical	1.4	---
15. Charts & Graphs	1.3	---
16. Graphical Math. & Nomography	1.2	---
17. Lettering	1.1	3.9
18. Miscellaneous	4.7	12.2
Total	100.0%	100.0%

Finally, the questionnaire asked for comments, from the respondents, to the question "In what way should, or could, the Engineering Graphics Division of A. S. E. E. be of assistance to the faculty of technical programs in two-year institutions?" All the comments which were received are listed in Table C. Many of these indicate a desire for increased communication

between our Division and themselves in the form of recommended course outlines and current information on the status of Graphics, both in academic and the industrial world. Suggestions appeared also that workshops be established which would be designed specifically to aid the graphics instructors in the two-year colleges to develop improved teaching techniques and to bring them up to date on new trends in graphics education.

Thus it is evident that these teachers wish to have closer liaison

Thus it is evident that these teachers wish to have closer liaison with the Division. It should be the Division's concern to furnish the assistance requested. After all, if we do not provide professional advice and encouragement, to whom can these colleagues turn?

When the Division decides to sponsor a workshop or conference for the benefit of the junior college graphics teachers, the Educational Relations Committee will be ready to assist most enthusiastically in the preparation of such a program.

Submitted by: Klaus E. Kroner  
 Submitted by: Klaus E. Kroner  
 Assoc. Prof.  
 Basic Engineering  
 Univ. of Mass.  
 Chmn. - E.R.C.

TABLE C

COMMENTS TO: "In What Way Should or Could the Engineering Graphics Division of ASEE be of Assistance to Faculty of Technical Programs in Two-Year Institutions?"

1. Prepare list of curriculum recommendations for graphical courses.
2. Develop program which is recognized by the 4-year schools.
3. Publish course outlines from various other colleges so faculty members will know what other schools are doing.
4. Inform us of the graphics responsibilities from year to year. What is being taught (topics) in Graphics?
5. Devise a basic engineering graphics course that is the same for all 4-year colleges.
6. Provide outlines of courses we should offer so that our students will not have difficulty in transferring to 4-year institutions.
7. Have 4-year programs in the areas that 2-year programs cover, so that students may continue and pursue a BS.
8. Keep the engineering graphics and technical drafting (terminal program) as closely related as possible. This would tend to strengthen both programs.
9. Advise as to which areas of graphics or other fields are considered to be the most important in the engineering field. This could be helpful in terms of emphasis.
10. Advise by predicting trends in the program.
11. What does Industry need and want?
12. Give educators some guidance, recommendations, and information.
13. Aid the faculty in keeping up with trends in institutions that are potential employers of the student graduates and aid in keeping the institution (educational) abreast of progress.
14. Plan workshops, provide list of available instruction aids in Graphics.
15. Offer work-shops in the summer with men from Industry on the program. They can explain what they want the student to know to be maintained in Industry.
16. Establish work-shops for the primary purpose of paralleling the basic engineering drawing course. Not so much in sequence, but in content.
17. Affording up-to-date drafting standards, techniques, and ideas to keep adjacent with Industry.
18. Don't forget the vast number of not-so-gifted that the community colleges serve. Try to pinpoint common denominator needs of Industry for lower level graphical work.
19. Information on new equipment.
20. Advise as to new methods and technologies; advise as to how better to distribute the assigned material, which courses have the priority.
21. Promote 4-year programs in technical or industrial education to allow students with a 2-year AS degree in occupational programs to transfer without loss of credits.
22. Know the teachers of technical courses in your particular geographical area. Meet with them.
23. Send appropriate publications lists to all graphics instructors.
24. Teach more down-to-earth practical drafting and not the theory that is piled in the ASEE Engineering Graphics Magazine.
25. In my opinion, a good program is a good instructor. If money is to be spent, spend it on a good instructor.

MID — YEAR MEETING  
LOUISIANA STATE UNIVERSITY  
January 1969

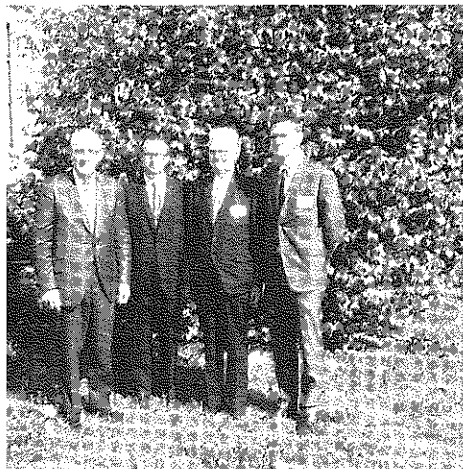

Host Committee  
Mid-Year Meeting  
Louisiana State University



Division Chairman, Earl Black  
talks with LSU Host, Bill Street

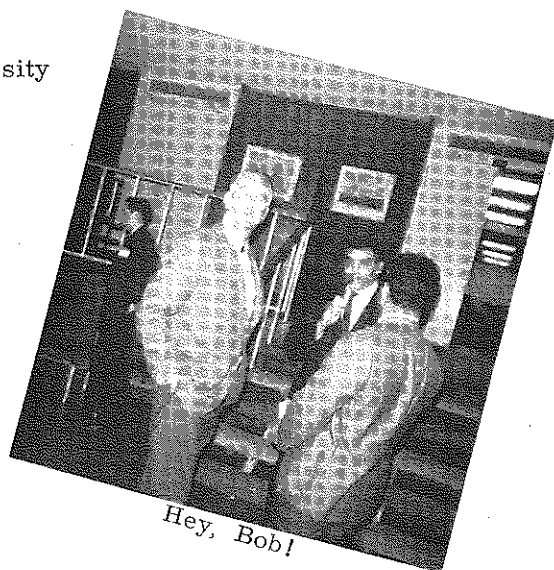

Hey, Bob!

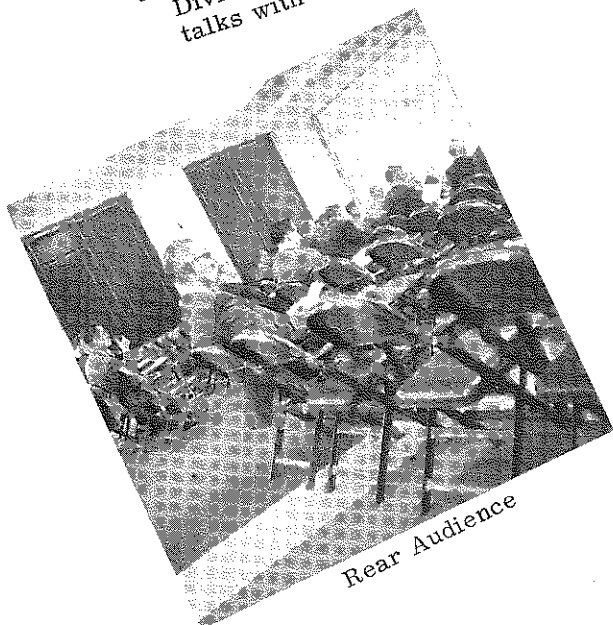

Rear Audience



Spy for 1970

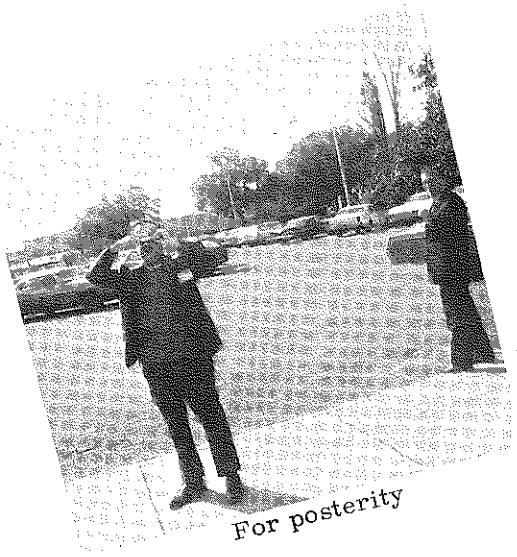

For posterity

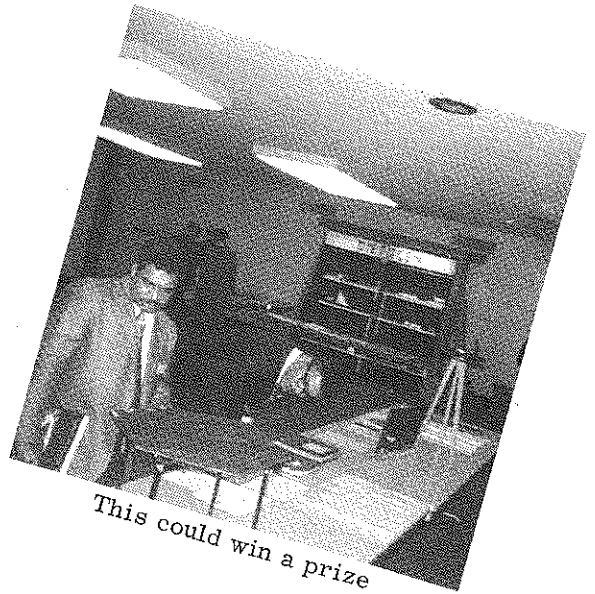

This could win a prize

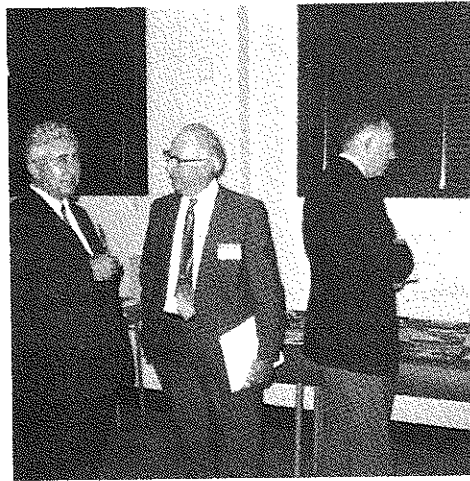

"Where were you?"



Missed my ride!



Coming or going?



ASEE ANNUAL CONVENTION  
PENNSYLVANIA STATE UNIVERSITY  
June 1969

ENGINEERING GRAPHICS DIVISION  
PROGRAM

Sunday, June 22

6:00-10:30 p. m.

Executive Committee  
Dinner & Business Meeting  
Earl Black - presiding

Making Preparations for Class.  
Securing Student Participation.

Sunday, June 22

10:00 a. m. -9:00 p. m.

Display of Student's Projects  
C. C. Cooley - chairman  
R. J. Foster - Coordinator

Tuesday, June 24

12:00-3:30 p. m.

Luncheon & Business Meeting  
Steve M. Slaby - presiding

Wednesday, June 25

10:00-11:45 a. m.

Conference

James H. Earle - presiding

"The Engineer and His Responsibilities  
in Communication"

Eivind Ramberg

Newark College of Engineering

"Legal Responsibility of the Engineer"

Daniel L. Griffin, Jr.

Iowa State University

"The Engineer's Responsibility in  
Developing Engineering Standards"

Roy P. Trowbridge

Director of Engineering Standards  
General Motors Corporat

Monday, June 23

8:00 a. m. -9:00 p. m.

Display of Student's Projects  
Judging of Projects  
A. L. Hoag - chairman

Tuesday, June 24

10:00-11:45 a. m.

Conference

Steve M. Slaby - chairman

Panel Discussion

"Creativity, Communication, and  
Teaching Techniques"

1. Ivan L. Hill

Illinois Institute of Technology

2. Hugh S. Rogers

Pennsylvania State University

3. James S. Blackman

University of Nebraska

Topics

Developing Engineering Graphics  
Courses.

Wednesday, June 25

6:30 p. m.

Annual Division Banquet

Earl D. Black - presiding

Award of Distinguished Service Award

Recognition of Division Officers

"Where Were You"

George J. Cowell

University of South Florida

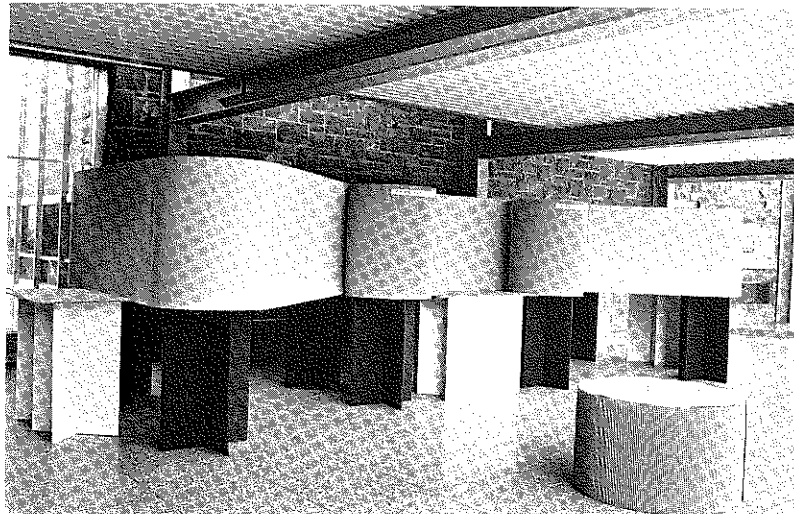

Part of Design Display Area at Penn State



The Annual Meeting of ASEE has become one of great interest to those who are engaged in teaching Introductory Creative Design. The first Design Display (June 1968 at UCLA) was an experiment on the part of the Engineering Graphics Division which proved to be extremely successful. The exhibit was visited by many people from all engineering disciplines and was well received. Plans are now being made for the Second Annual Introductory Creative Design Display.

it may be a difficult task, he seems sure that the needs of the Division will be met with more satisfaction than in the past. This means that accommodations will be better and cooperation will be greater (a very difficult task) for the event that has proven to be beneficial to our discipline ----- The Annual Introductory Design Display.



Robert J. Foster



C. C. Cooley

Through the efforts of C. C. Cooley (University of Detroit, and Robert J. Foster (Penn State University) the next Introductory Design Display should set the pace for the future. Bob Foster is making every effort to secure a location close to the main exhibit area so that it will be more convenient for everyone to visit. Although

Professor C. C. Cooley is now in the process of organizing the main event. All indications point to the fact that he, too, is dedicated to better results --- if that is possible ----- that were achieved by John Barylski. This, of course, can be done with the cooperation of all who are engaged in teaching this subject.

---

REPORT OF THE DISPLAYS COMMITTEE

The Second Annual Introductory Design Display is planned for Pennsylvania State University during the ASEE Annual Meeting in June 1969.

Since early in September, of the current school year, planning for this Second Annual Display of Student Designs has been under way.

Those who attended the UCLA meeting in June, 1968 will recall that, under the leadership of Professor John R. Barylski of SMTI in New Bedford, Massachusetts, the first such display effort was presented and well received.

For the current year Chairman Earl Black of the Division of Engineering Graphics has appointed the following to the Displays Committee:

- C. C. Cooley - chairman  
University of Detroit  
College of Engineering  
Department of Design & Simulation  
Detroit, Michigan 48221  
Phone - 342-1000, ext. 313
- Robert A. Britton  
University of Missouri at Rolla
- Roland O. Byers  
University of Idaho

William A. Earl  
 SUNY College of Ceramics  
 Robert J. Foster  
 Pennsylvania State University  
 Herbert T. Jenkins  
 University of Michigan  
 Junius H. Kellman  
 Ventura College  
 Jack T. Kimbrel  
 Washington State University  
 Joseph W. McCutchan  
 University of California of L. A.  
 Robert L. Ritter  
 Loyola University of Los Angeles  
 Jacob H. Sarver  
 University of Cincinnati  
 Marvin L. Weed  
 Penn State Univ. at McKeesport

Correspondence between the chairman and several committee members has resulted in progress toward final definition of the activity.

Graphics and Design teachers who plan to have student work submitted for competition should read the material below in order to effectively correlate their planning and effort for maximum results.

1. While the dollar amount of the prize monies has not been finalized, at this writing, every effort is being made to maximize the amount, recognizing that this is in itself a motivation to participate.
2. Categories for the displays will be, in all probability, as follows, with the related prizes distributed among these categories;
  - A. Designs including prototype, mock-up or model.
    1. Freshman - individual
    2. Freshman - team
    3. Sophomore - individual
    4. Sophomore - team
  - B. Designs without prototype, mock-up, or model.
    1. Freshman - individual
    2. Freshman - team
    3. Sophomore - individual
    4. Sophomore - team
3. Teachers planning to enter display materials in any of the categories are urged to write to the Chairman of the Displays Committee at an early date, furnishing an 8 1/2 x 11 sheet for file purposes, which gives the complete address, including phone number of the one person at the institution that all correspondence is to be directed to. Additionally and separately, the Chairman would appreciate tenta-

- tive information regarding the planned display. Include such information as approximate floor space needed, general physical form of the display and whether electrical power is needed for prototype operation.
4. The above 8 1/2 x 11 sheets will be used to form an address file. By April 1st, or earlier, a packet of entry blanks and all detailed information relative to entering your materials, will be sent to these addresses. This packet of material will attempt to spell out ALL information needed for entry.
  5. Between the present date and the April 1st date, communicate with the Chairman of the Displays Committee for "to-date" information relative to the display.
  6. LOOK FOR additional information in the Spring issue of the JOURNAL OF ENGINEERING GRAPHICS.
  7. At the Pennsylvania State University, College of Engineering, work has already been done, and the plans made for this event. Professor Robert J. Foster of Engineering Graphics has agreed to act as local coordinator and chairman of the activity. Professor Hugh Rogers of the same department is working one-quarter time to finalize the display format.

The accent on design so appropriately blended into the Engineering Graphics activity for Freshmen and Sophomores at colleges of engineering is bringing forth some excellent design work. It is surely a responsibility of the teachers to see that the members of ASEE generally and the Division of Engineering Graphics in particular are made aware of the fine work being done. One of the excellent ways to do this is to alert your students to this activity early in the school year, so that they may develop design projects suitable for entry, and, hopefully, of a caliber that will merit one or more of the prizes.

We look forward to seeing you and your student designs at Penn State, June 23-26, 1969.

As preparation of this material is being concluded, word comes from Mr. Frank Oppenheimer of Gramercy that Mr. Alfred Kreidler is once again donating \$1000 to this worthwhile activity. The writer has communicated his expression of appreciation to both these gentlemen on behalf of the Division of Engineering Graphics. Further details of this will appear in the Spring issue of the JOURNAL OF ENGINEERING GRAPHICS.

Professor C. C. Cooley  
 Chairman - Displays  
 Committee

TEACHING TECHNIQUES COMMITTEE  
REPORT

This is a summary based on on-going projects of committee members and other available information at this time.

Professor Klaus E. Kroner of the University of Massachusetts has prepared computer-mediated instructional programs for self-study or review programs which are stored in the computer. These programs operate like a programmed learning sequence where the student has specific questions directed to him on the computer from which he selects an answer (as from a multiple choice question). The computer indicates whether his answer is right or wrong, and gives reasons why it is right or wrong. The time required per program varies from 5 to 10 minutes. Programs have been written for Orthographic Projection and Fundamentals of Descriptive Geometry. He plans to add additional programs in the near future.

Professor William E. Schneerer of Case Institute of Technology has published a programmed learning text covering basic graphics content in engineering drawing, descriptive geometry and graphical calculus and mathematics. His text provides for self-testing throughout and a sketch pad for carrying out suggested drawing or sketching activities in conjunction with the text. He refers to the sketch pad as a pad for "doodling". This text is unique in the field of Engineering Graphics, as far as I know. It is excellently presented and illustrated and furnishes the Case student basic material in Graphics which he can learn or review. The Case student is not required to take Graphics, but the engineering faculty requires that he be able to demonstrate a proficiency in Graphics by passing an examination on the content put forth in Bill's text. It is also being used at Rochester Institute of Technology as review material for a proficiency examination which, if passed, allows the student to elect a course in Computer Graphics in lieu of the first required Graphics course.

The University of Minnesota faculty members in Engineering Graphics, Professors Springer, Palmer, and Clausen have produced a large volume of programmed learning material on many basic Engineering Graphics topics.

The chairman of the Teaching Techniques Committee has prepared three videotapes of a series of 10-12 Engineering Drawing lectures which he hopes to complete. The first is Orthographic Projection: Normal Surfaces, and includes discussion on reference planes, projection, arrangement of views, and the use of isometric drawing as an aid to visualization. The second and third are on Orthographic Projection:

Inclined Surfaces, Oblique Surfaces. Transparencies are used and in addition to presenting basic theory, problems are solved for a third view using surface and point labelling. Further presentations are planned on: Orthographic Projection, Cylindrical Surfaces, Auxiliary Views, Sectioning, Basic Dimensioning Principles, Tolerances and Limit Dimensions, Pictorial Drawing (Isometric and Oblique), Working Drawings. Also, beginning work in Computer Graphics, using the IBM plotter, has been tried for three view drawings and tentative plans are being made to combine the Fortran language and the matrix transformation of coordinates in three dimensions to that of two dimensions so as to effect the isometric or perspective drawing of objects in rotated and translated positions as may be desired.

Professor Ludwig Schweinfurth of the University of Puerto Rico is undertaking an elaborate doctoral study at Texas A & M University under the direction of the Engineering Graphics Department which shows great promise. He seeks to formulate an Engineering Graphics program for the University of Puerto Rico based on the best thinking of authorities in the field and other persons having a concern for graphics. At present he has worked up a comprehensive set of objectives to be critically evaluated by the experts.

Professor Carl J. Buckman has conducted a worthwhile survey of 55 colleges and universities from which 38 schools responded to the many questions asked regarding whether or not they utilize certain teaching techniques and methods in the teaching of engineering graphics courses; and if so, their rating of the relative value of each technique. He has explored the uses of all the visual aids and materials used in recent years, and has looked into techniques being used in the presentation of computer graphics. In my opinion, his study clearly merits publication in the JOURNAL OF ENGINEERING GRAPHICS. As far as I know, it represents the only analysis of this kind and he has authorized me to have it published in an early edition of the Journal as practical. The chairman believes that Professor Buckman (now retired) merits a high commendation from all of us for his exceptional efforts on behalf of the Teaching Techniques Committee and for this comprehensive analysis of teaching techniques which has potential usefulness to all of us.

Dr. Ernest C. Schamehorn - chairman  
Teaching Techniques Committee

REPORT OF  
BIBLIOGRAPHY COMMITTEE

The following publications are now available:

<u>AUTHORS</u>	<u>TITLE</u>	<u>PUBLISHER</u>	<u>ED.</u>	<u>YEAR</u>	<u>PAGES</u>	<u>PRICE</u>
Almfeldt, M. W. Arnbal, C.A.	ENGR. GRAPHICS PROB. BK. II	Wm. C. Brown	1	1967	125	4.50
Beakley, G. C.	ENGINEERING; AN INTRO. TO A CREATIVE PROFES- SION	MacMillan Co.	1	1967	548	9.95
Calendar, H. L. Brown, W. J.	ENGR. PROB. FOR FUND. OF 3-D DESCR. GEOMETRY	Harcourt, Brace and World	1	1967	82	5.50
Cowell, G. J.	ENGR. GRAPHICS PROB. BK.	Wm. C. Brown	1	1966	110	4.00
Earle, J. H. Cleland, S. M. Oliver, J. P. Mason, P. M. Bardell, N. B. Guerard, M. P.	DESIGN AND DESCRIP. GEOMETRY PROB. I	Addison-Wesley	1	1967	60	3.95
Earle, J. H.	ENGR. GRAPHICS AND DESIGN PROBLEMS I	Addison-Wesley	1	1967	68	3.95
Fetter, W. A.	COMPUTER GRAPHICS IN COMMUNICATION	McGraw-Hill	1	1965	110	
French, T. E. Vierck, C. J.	A MANUAL OF ENGR. DRAWING FOR DTUDENTS AND DRAFTSMEN	McGraw-Hill	10	1966	701	9.95
French, T. E. Vierck, C. J.	FUND. OF ENGR. DWG.	McGraw-Hill	2	1966	576	7.95
Giesecke, F. E. Mitchell, A. Spencer, H. C.	TECHNICAL DRAWING	MacMillan	5	1967	882	9.95
Giesecke, F. E. Mitchell, A. Spencer, H. C.	TECH. DWG. PROB. SERIES I, MANUAL	MacMillan	4	1967	103	5.95
Grant, H. E.	ENGR. DWG. WITH CREATIVE DESIGN	McGraw-Hill	1	1968		
Hamilton Hotchkiss	WORKSHEETS FOR BASIC GRAPHICS	Wm. C. Brown	1	1967	93	5.75
Heacock, F. A.	GRAPHICS IN SPACE FLIGHT	McGraw-Hill	1	1964	144	4.50 h. c. 2.50 s. c.
Henry	PROB. IN ENGR. GRAPHICS, SERIES A	Wm. C. Brown	1	1965	48	2.55
Hornung, W. J.	ARCHITECTURAL DRAFT.	Prentice-Hall	4	1966	277	9.12

## Bibliography Committee Report (continued)

<u>AUTHORS</u>	<u>TITLE</u>	<u>PUBLISHERS</u>	<u>ED.</u>	<u>YEAR</u>	<u>PAGES</u>	<u>PRICE</u>
Hill, P. H.	ENGR. GRAPHICS AND DESIGN PROB. SHEETS AND DESIGN PROJECTS BOOKLET	MacMillan	1	1964	44	7.75
Hill, P. H.	A SHORT COURSE IN ENGR. GRAPHICS AND DESIGN PROB. SHEETS AND DESIGN PROJECTS BOOKLET	MacMillan	1	1964	24	5.50
Levens, A. S. Edstrom, A. E.	PROB. IN MECH DWG. 2nd COURSE WORKSHOP CORR. WITH MECH. DWG.	McGraw-Hill	3	1967	176	3.95
Lindgren, C. E. S.	FOUR DIMENSIONAL DESCR. GEOMETRY	McGraw-Hill	1	1968	129	
Luzadder, W. J.	FUND. OF ENGR. DWG.	Prentice-Hall	5	1965	726	10.95
Luzadder, W. J.	BASIC GRAPHICS FOR DESIGN ANALYSIS, COMMUNICATIONS AND COMPUTERS	Prentice-Hall	2	1968	656	9.95
Luzadder, W. J. Arnold, N. J. Thompson, F. H.	PROB. IN ENGR. DWG. (Workbook)	Prentice-Hall	5	1966	71	4.95
Martin C. L.	DESIGN GRAPHICS	MacMillan	2	1968	320	9.95
McCartney, T. O.	PRECISION PERSPECTIVE DWG.	McGraw-Hill	1	1963	256	11.00
Muller, E. J.	ARCH. DRAWING AND LIGHT CONSTRUCTION	Prentice-Hall	1	1967	450	10.95
Paré, E. G. Loving, R. O. Hill, I. L.	DESCR. GEOMETRY	MacMillan	3	1965	383	6.50
Raskhodoff, N. M.	ELECTRONIC DRAFT. AND DESIGN	Prentice-Hall	1	1966	594	12.95
Paré, E. G. Loving, R. O. Hill, I. L.	DESCR. GEOMETRY WORKSHEETS SERIES A SERIES B SERIES C	MacMillan		1968 1966 1967	76 76 72	4.95 4.95 4.95
Rising, J. S. Arnbal, C. A.	ENGR. GRAPHICS PROBLEM BOOK I	Wm. C. Brown	1	1964	406	7.25
Seid, R.	APPLIED PROB. FOR FUND. OF 3-D DESCR. GEOMETRY	Harcourt, Brace, and World	1	1967	70	5.00
Shiels	PROB. IN DESCR. GEOM.	Wm. C. Brown	1	1966	99	3.25
Shiers, G.	DESIGN AND CONSTR. OF ELECTRONIC EQUIP.	Prentice-Hall	1	1966	362	11.25

## Bibliography Committee Report (continued)

<u>AUTHORS</u>	<u>TITLE</u>	<u>PUBLISHER</u>	<u>ED.</u>	<u>YEAR</u>	<u>PAGES</u>	<u>PRICE</u>
Silberg, M. D. Halasz, S. T.	WORKSHEETS IN GRAPH. SCIENCE AND CREATIVE DESIGN	Prentice-Hall	1	1965	104	7.95
Slaby, S. M.	FUND. OF 3-D DESCR. GEOMETRY	Harcourt, Brace, and World	1	1966	383	7.95
Slaby, S. M. Gum, H. S.	WORKBOOK FOR FUND. OF 3-D DESCR. GEOMETRY	Harcourt, Brace and World	1	1966	72	5.95
Street, W. E.	TECH. DESCR. GEOM.	D. Van Nostrand	2	1966	192	5.50
Thornhill, R. E.	ENGR. GRAPHICS AND NUMERICAL CONTROL	McGraw-Hill	1	1967	349	
Vierck, C. J. Hang, R. I.	FUND. OF ENGR. DWG. PROBLEMS	McGraw-Hill	2	1968		
Vierck, C. J. Hang, R. I.	ENGR. DWG. PROB.	McGraw-Hill	2	1968		
Wellman, B. L.	INTRO. TO GRAPH. ANALYSIS AND DESIGN	McGraw-Hill	1	1966	559	8.95
Woodworth, F. M.	GRAPHICAL SIMULATION	International Textbook	1	1967	574	9.00
Zulauf, E. C. Burnett, J. R.	INTRODUCTORY ANALOG COMPUTATION WITH GRAPHICAL SOLUTIONS	McGraw-Hill	1	1966	128	4.95 h.c. 2.50 s.c.

The above information was furnished by publishers. Some publications may have been omitted. The Bibliography Committee is making every effort to complete the list and any additions will be printed in the JOURNAL OF ENGINEERING GRAPHICS as they are obtained.

Respectfully submitted  
Wayne Felbarth - chairman

---

 NEW BOOKS

MANUAL OF STRUCTURAL DETAILS FOR  
BUILDING CONSTRUCTION - Alonzo Wass.  
Prentice-Hall - 1968 - 386 pages.

Designed for self-instruction, including  
reviews of drawing practice, construction  
symbols, and information from the whole range  
of building construction.

ENGINEERING DESIGN GRAPHICS - James H.  
Earle - Addison Wesley - 1969 - 757 pages

A text which integrates the Engineering  
Graphics with the study of Introductory  
Creative Design and the Design Process.

# DECIMAL CIRCLE PROVEN FOUR TIMES EASIER!

Twice as many answers found in half the publishing space.

For a free copy from p. 83 Mar' 67 ASCE magazine phone or write me:

## DIAGRAM OF PRINCIPLE .....

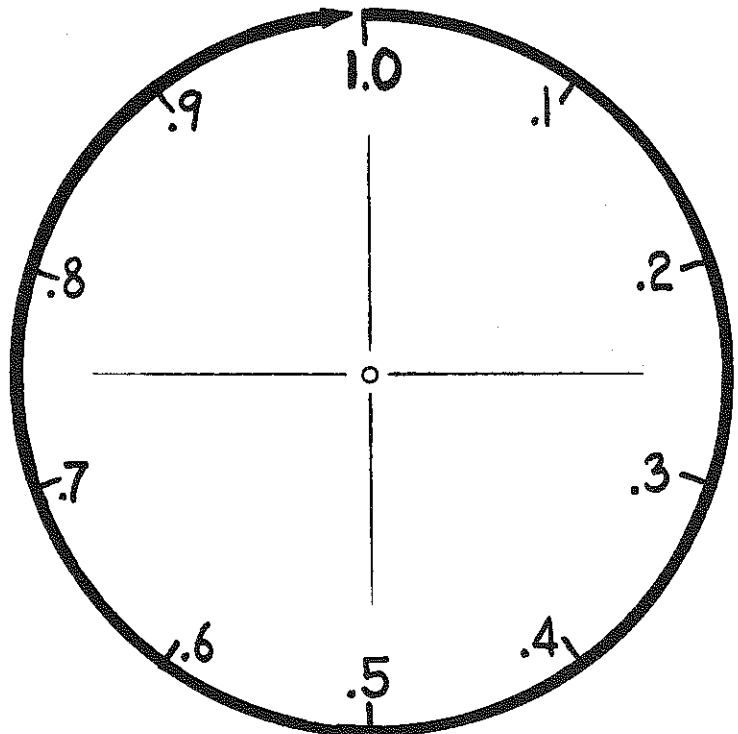

**UNIT PROTRACTORS** \$1 each retail, \$60/100 whlse.  
Phone buyer at campus bookstore, or mail your check to:

Unit Protractors are calibrated to decimal circle principle. Scale of 1000 division marks per revolution, see-through plastic, 5" diam. One instruction sheet and sample calculation free with each order. Used by budget illustrators, satellite trackers, frequency calibrators, utility meters, odometers, tachometers. Worthy of wider application. Works copyrighted 1962,3,4. Item copyrighted 1964 and reprinted by California Council of CE & LS 1965,6. Advertisement © Landsite 1968 world rights reserved except for potentiometers, daymeters, sextants, sundials, plans, calculations, reports, reviews, articles, textbooks.

**ROGER ALGEE, E. I. T.**  
2611 SPRING STREET  
PASO ROBLES, CALIF. 93446  
Telephone (805) 238-3739

# Engineering Graphics texts

*Now for courses that combine  
technical drawing  
descriptive geometry, and  
graphs, graphical computation, and design—*

## ENGINEERING GRAPHICS

By the late Frederick E. Giesecke; the late Alva Mitchell;  
Henry Cecil Spencer, on leave, The Illinois Institute of Technology;  
and Ivan Leroy Hill and Robert Olin Loving, both of The Illinois Institute  
of Technology

Based largely upon the authors' classic text, *Technical Drawing*, this new book is designed so that it may be used effectively in either a one- or two-semester course combining technical drawing, descriptive geometry, graphs, graphical computation, and design.

### New Chapters on Descriptive Geometry

*Engineering Graphics* incorporates several new chapters on descriptive geometry, covering Points, Lines, and Planes; Parallelism and Perpendicularity; Intersections; Developments; Line and Plane Tangencies; Cartography; Geology and Spherical Geometry; and Graphical Vector Analysis. A less time consuming system of notation consisting of simple arabic numbers is introduced in these chapters.

Reflecting the high standards that teachers have appreciated in *Technical Drawing*, the new *Engineering Graphics* includes a wealth of carefully executed illustrations and original problems.

Beginning with a section on technical drawing, the text proceeds to descriptive geometry, then to graphs, graphical computation, and design. Throughout, the authors employ the same clear, teachable style that made their previous book the leader in its field.

### Emphasis on Technical Sketching

Outstanding in the first section on technical drawing is the emphasis on technical sketching. The approach is unique in that it integrates the basic concepts of views with freehand technique so that the subject of multiview drawing can be introduced through the medium of sketches.

*Engineering Graphics* conforms throughout to the latest *USA Standard Drafting Manual Y 14.*, and includes many technological developments of the past few years.

1969, approx. 928 pages, \$10.95

In addition to the problems in the text, a *new* complete workbook covering all major topics will be available for use with *Engineering Graphics*:

*Engineering Graphics Problems, Series 1*, by Henry Cecil Spencer, Ivan Leroy Hill, and Robert Olin Loving, 1969, approx. 114 sheets, paper, prob. \$5.95



# from The Macmillan Company

## *Popular texts and workbooks for basic courses.*

### **Technical Drawing, Fifth Edition**

By the late Frederick E. Giesecke; the late Alva Mitchell; Henry Cecil Spencer; and Ivan Leroy Hill

The number one text in its field, *Technical Drawing*, Fifth Edition has been thoroughly revised according to the current USA Y 14 American Standard Drafting Manual, including the latest American Standard on Dimensioning and Tolerancing for Engineering Drawings. The very recent emphasis on "design in engineering" has been developed with the cooperation of leading engineers and manufacturers who represent the most current thinking in technical drawing.

1967, 882 pages, \$9.95

(A full program of supplementary materials is available.)

### **Design Graphics, Second Edition**

By C. Leslie Martin, University of Cincinnati

Thoroughly updated, and containing a wealth of new material, this text provides the most complete and comprehensive treatment of graphical representation available today. It presents in step-by-step fashion all the concepts and skills necessary for developing and presenting a design. Exceptionally well illustrated, *Design Graphics* covers every topic of use to students or professionals in this field.

1968, 307 pages, \$9.95

### **Descriptive Geometry Worksheets**

Series A, B, and C

By E. G. Paré, Washington State University, R. O. Loving, and I. L. Hill, both of The Illinois Institute of Technology

Designed to accompany any textbook on descriptive geometry, these workbooks contain practical problems as well as problems that teach relevant theory. They have been prepared to show the usefulness of graphics in solving spatial relationships of points, lines, and planes in engineering and technology.

Series A, Third Edition  
1968, 77 sheets, paper, \$4.95  
(Key to Series A available, gratis)

Series B, Second Edition  
1966, 76 sheets, paper, \$4.95  
(Key to Series B available, gratis)

Series C, Second Edition  
1967, 72 sheets, paper, \$4.95  
(Key to Series C available, gratis)

Write to the Faculty Service Desk for examination copies.

**THE MACMILLAN COMPANY**, 866 Third Avenue, New York, New York 10022

In Canada, write to Collier-Macmillan Canada, Ltd., 1125B Leslie Street, Don Mills, Ontario

# THE SPACING DIVIDER

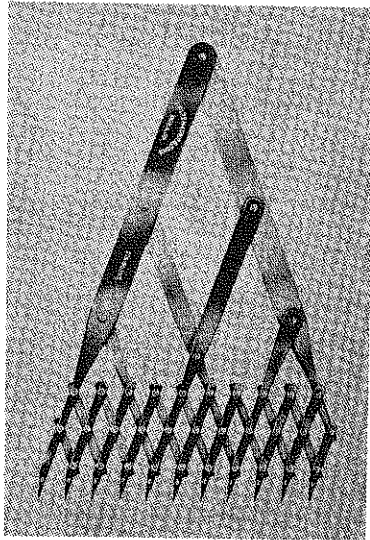

No. 2960—6 INCH  
(ILLUSTRATION HALF SIZE)

This instrument consists of eleven points so adjusted that they divide their variable setting into ten or less equal parts. It can also be used inversely to give multiples up to ten and in graphic solution of ratios. Adjustable distance between points on the 6 Inch Instrument is minimum  $\frac{3}{16}$ " , maximum  $\frac{5}{8}$ " and on the 12 Inch minimum  $\frac{1}{4}$ " , maximum  $1\frac{1}{4}$ " .

## Catalog on Request Covering:

Drawing Instruments

Protractors

Rolling Parallel Rules

11 Pt. Spacing Dividers

Drafting Scales

S.S. Straightedges

S.S. T-Squares

S.S. Triangles

Circular and Linear Engraving

for the

DRAFTING ROOM—PATTERN LOFT—LAYOUT TABLE

**THEO. ALTENEDER & SONS**

*Makers of Fine Instruments Since 1850*

1217 Spring Garden Street

Philadelphia 23, Pa.

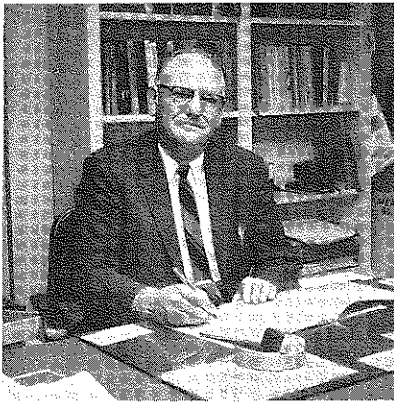

# TEACHING THE DESIGN PROCESS IN THE FRESHMAN YEAR

by

Professor Ralph M. Coleman  
Department of Engineering Graphics  
University of Texas at El Paso

It is not a matter of whether engineering design concepts and procedures will be taught in the freshman graphics courses, but rather how it will be taught.

There are at least two schools of thought as to how design projects can be included in the freshman year and successfully executed by beginning graphics students. The first method, which appears to be prevalent in many colleges and universities, is to apply the fundamentals of drawing as the need presents itself in the design project. The second method is to teach the fundamentals as engineering problems and then devote six to eight weeks to the design projects and the design process. Both methods have been used by the author, for approximately eighteen years with success, but the second method has proven to be best suited to the general needs of the student as his training will relate to industry.

Each method will have some disadvantages which will be obvious to the experienced instructor. There is a danger in the "need to know" method since the student may work on a design project which will give him only a limited knowledge of certain kinds of drawings such as multiview, sections, and insufficient knowledge of dimensioning and tolerancing. This danger would not exist in schools where graphics is taught for two or more semesters or where the design process can be included in the sophomore year.

Regardless of the method used, the so-called "basic fundamentals" must be included in the freshman year. It is an established fact that the design process can be taught to freshman students if proper detailed planning and organization is used.

Over the past twenty years the author has developed a process and organizational procedure which might be of some help to those instructors who have, as yet, not included de-

sign in their freshman graphics courses. Many good authors and professors have contributed much valuable information and many suggestions in developing the procedures used at the University of Texas at El Paso. The organization and procedures will be outlined in a step by step explanation. The time at which the design project is assigned is of minor importance in relation to the overall learning process. The steps as listed do not necessarily have to be followed in the order in which they are given in this discussion.

STEP 1. When introducing the design process, a thirty or forty-five minute lecture should be prepared. If possible, have an engineer from industry give a part of the lecture. The well-planned lecture will be supplemented with actual models, slides, and charts. The visiting engineer must be selected with great care. It is in this step that additional motivation must be given to the student engineer.

STEP 2. Discuss and explain the design process by having the students suggest several ideas for designs. As they are suggested, list them on the blackboard. Take one of the ideas and establish the need, goals to be accomplished, research all possible sources of information, various concepts of the design, experimentation, manufacture, distribution and consumption, etc. Discuss all phases of the design.

STEP 3. In the third step the instructor should assume the role of administrative engineer and proceed to organize the student engineers into satisfactory groups as to size, student schedules, engineering interest (major field), availability to meet at specified times other than regular class hours, etc. A form similar to the one shown as

Form 1 may be used. This form can be passed out before the first step, if it is desirable. After the forms have been collected and the information analyzed, the Administrative Engineer can form as many groups as are needed to include all students. Each group should have from three to six students.

ENGR. DESIGN

1. COURSE: \_\_\_\_\_ SECTION: \_\_\_\_\_

2. YOUR NAME: \_\_\_\_\_ AGE: \_\_\_\_\_  
Last First

3. ENGR. INTEREST (Show 1st, 2nd, and 3rd choices by placing 1, 2, 3, in the circles.)

MECHANICAL    CIVIL    ELECTRICAL    INDUSTRIAL  
 CHEMICAL    ARCH.    ENGR. MECHS.    ENGR. SCS.  
 METALLURGY    OTHER

4. YOUR CLASSIFICATION  Freshman  Soph.  Junior  Senior

5. FILL OUT FOLLOWING WEEKLY SCHEDULE, MARKING COURSES TAKEN IN APPROPRIATE TIMES, IF UNAVAILABLE AT OTHER TIMES, MARK "W" IN CORRESPONDING PLACE.

HOURS	MON.	TUE.	WED.	THURS.	FRI.	SAT.
8:00-9:00						
9:00-10:00						
10:00-11:00						
11:00-12:00						
12:00-1:00						
1:00-2:00						
2:00-3:00						
3:00-4:00						
4:00-5:00						

6. YOUR CAMPUS ADDRESS: \_\_\_\_\_ TEL. NO. \_\_\_\_\_

7. YOUR HOME ADDRESS: \_\_\_\_\_ TEL. NO. \_\_\_\_\_

8. NAMES OF OTHER STUDENTS IN YOUR SECTION WITH WHOM YOU MIGHT LIKE TO JOIN AS A STUDENT GROUP.  
 \_\_\_\_\_  
 \_\_\_\_\_

9. CAN YOU BE FREE FOR GROUP MEETINGS (ON CAMPUS) ON WEEKDAY NIGHTS? \_\_\_\_\_ ON SATURDAYS? \_\_\_\_\_

10. REMARKS: \_\_\_\_\_  
 \_\_\_\_\_  
 \_\_\_\_\_

FORM 1.

**STEP 4.** Announce, to the student, which group he will work with.

**STEP 5.** Appoint a "Project Engineer" within each group or permit the group to select their own leader. Announce that all others in the group will have the title of Assistant Project Engineer. At this point, the administrative engineer must stress that the project engineer is responsible for the work of his assistants and must make regular reports to the administrative engineer.

**STEP 6.** Pass out a form similar to the one shown as Form 2. On this form, members of each group will suggest ideas for their design project. The Administrative Engineer must analyze the feasibility and scope of the suggestions in relation to the time allotted and the students' ability. They will call upon many sources for information. Should any group fail to suggest a feasible project, the Administrative Engi-

ENGR. DESIGN

DATE: \_\_\_\_\_

DESIGN IDEAS

The following idea or ideas are hereby submitted for consideration as a design project to be completed this semester in partial fulfillment for credit in Engineering Graphics.

Idea #1. \_\_\_\_\_  
 \_\_\_\_\_  
 \_\_\_\_\_  
 \_\_\_\_\_

Idea #2. \_\_\_\_\_  
 \_\_\_\_\_  
 \_\_\_\_\_  
 \_\_\_\_\_

Idea #3. \_\_\_\_\_  
 \_\_\_\_\_  
 \_\_\_\_\_  
 \_\_\_\_\_

Respectively Submitted By:  
 \_\_\_\_\_  
Last First Middle

FORM 2.

neer must be prepared to suggest a large number of ideas. Without exception one of the design ideas will be accepted.

**STEP 7.** After the project has been decided upon, pass out a sufficient supply of reporting forms similar to Form 3. Explain the reporting form and again stress the importance of the role of the Project Engineer in listing the work accomplished, the work planned for the next session or group meeting, or the failure to work by anyone in his group. The Project Engineer's signature as well as that of the Assistant Engineer must appear on every report. This type of reporting will prevent non-performance by various individuals.

The reports are turned in to the Administrative Engineer at the end of each class period. The report must be studied in every detail so that the status of each project will be known at all times.

**NOTE:** A large graph, posted where all groups can compare their progress with that of the others, has been found to be useful by the author. The chart or graph can be kept current by the office secretary or lab assistant.

ENGR. DESIGN  
DESIGN PROJECT  
Individual Progress report

Name of Project \_\_\_\_\_  
Name of Project Engineer: \_\_\_\_\_ Date \_\_\_\_\_  
Report No. \_\_\_\_\_

Work Completed Last Period: (Give Details)

Work Planned for Next Period: (Give Details)

Record of Time Spent:

	Tasks Worked On
Hours Expended	_____
○	_____
	_____
	_____
	_____

Section No. \_\_\_\_\_ Signature of Assistant Project Engineer  
Group No. \_\_\_\_\_ Signature of Project Engineer

FORM 3.

**STEP 8.** After the first seven steps have been initiated and are functioning, call an executive meeting of all Project Engineers and conduct the meeting in the form of a conference. The meeting place should not be in a regular class room if it can be avoided. The meeting place should give the impression of a board of directors' meeting with name plates for each Project Engineer placed on the conference table. At these meetings, which should be called at least once a week, an oral report is given in a formal manner, by each Project Engineer, as to the status of his group's design project. If possible, the Administrative Engineer should have his secretary present to take notes on each report, not for the purpose of grading, but as a matter of record-keeping. The Project Engineers should be informed of this procedure. Each report should be limited to 5-8 minutes.

About once each week the Assistant Engineers of all the projects should be assembled without the presence of the Project Engineers. In these sessions, problems in each group may be discussed and solutions found. By meeting with the Assistant Engineers, no one will feel that he is left out of the overall plan. It can also be determined,

in these meetings, whether the Project Engineers are functioning in a satisfactory manner.

A few of the design projects accomplished in the freshman year, at the University of Texas at El Paso, are shown in the following figures.

In Figure 1 the problem was to design an educational toy for use in the Head Start program. This design has attracted the interest of firms concerned with the manufacture of educational toys. No details of the toy will be mentioned because of the present exposure for manufacture.



Figure 1

In Figure 2 the problem was to design an AUTOMATIC SWITCHING JUNCTION BOX which would allow several items of equipment to be operated using one generator and provide a means of switching generators without de-energizing the equipment.

The students shown in Figure 3 are demonstrating and explaining, in the oral report, their concept of an overpass for pedestrians on the U. T. El Paso campus.

Figure 4 is a proposed Siren System to activate a car radio to let the driver know that an ambulance or police car is demanding the right-of-way. Research had to be done through Federal Communications to

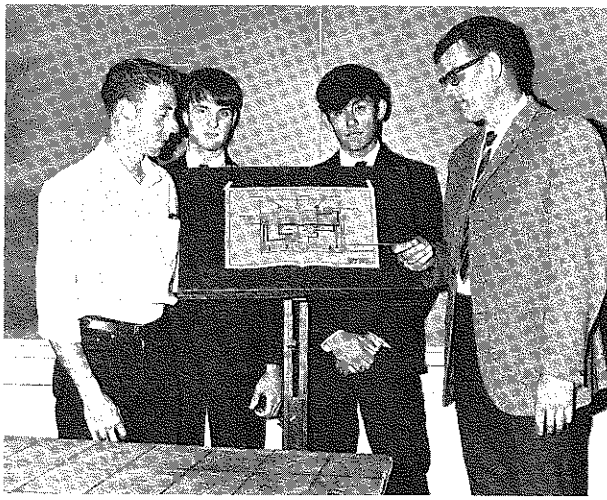

Figure 2

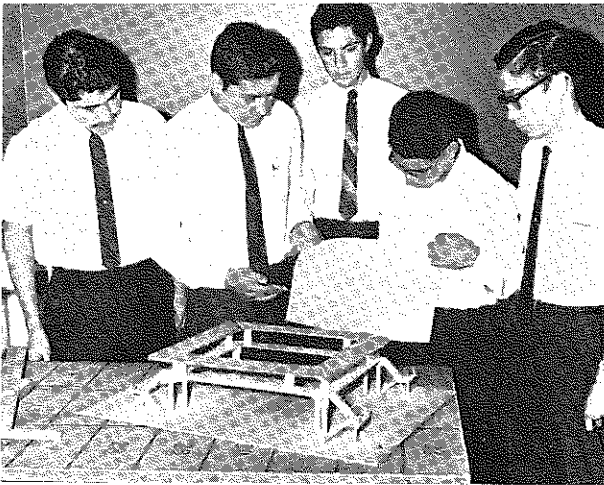

Figure 3

determine a frequency and other lawful aspects. The working model illustrates that considerable technical knowledge and research was used.

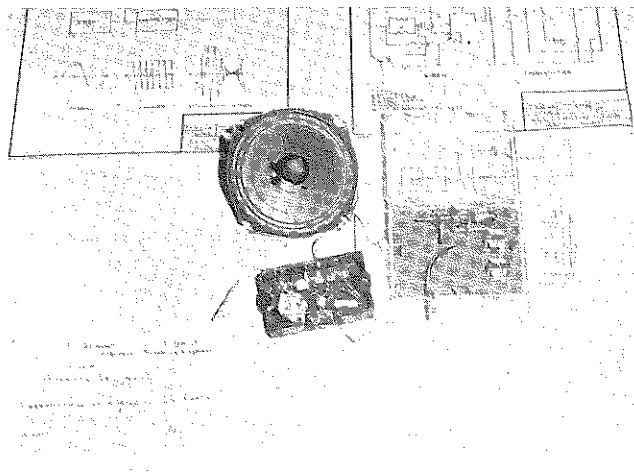

Figure 4

Figure 5 is a proposed Monrail System connecting the two international cities of Juarez and El Paso. At first, this project appeared to have a scope beyond the ability of the freshman student. Such was not the case. The design of the mechanical structures and humanistic elements, such as load, time, cost, immigration inspection, etc. was an excellent example of what a group of freshman engineering students can really do.

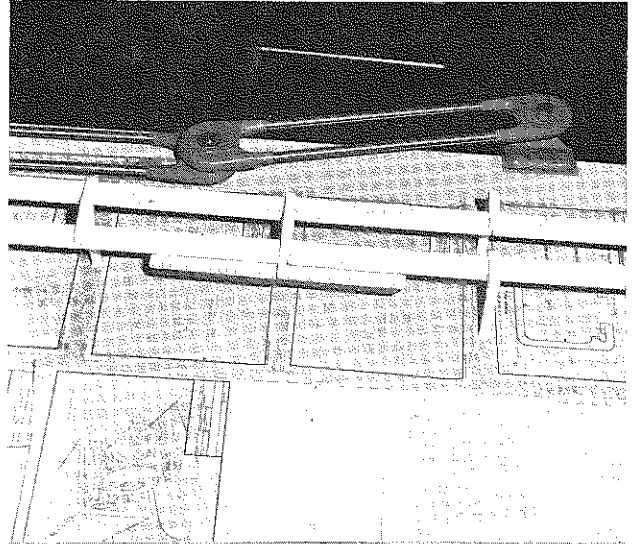

Figure 5a

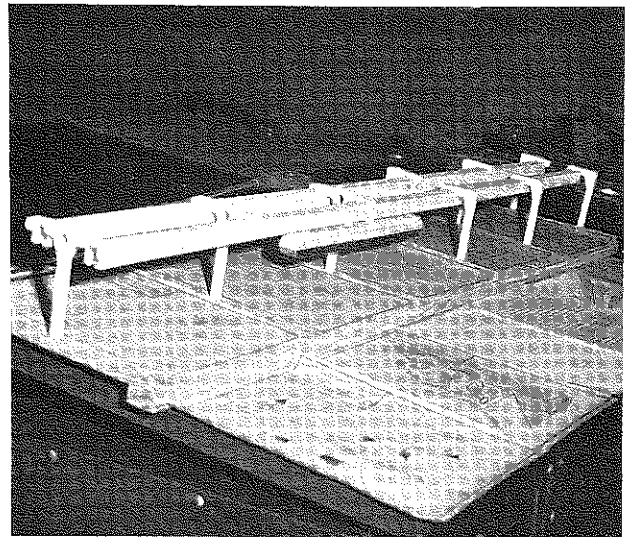

Figure 5b

For the wives who have trouble backing the family car onto the street, may use a turntable such as the design shown in the Figure 6. The prototype is a good example in teaching gears, gear ratios, and the use of standard materials when possible.

The teaching, or coordination, of graphics with the use of the computer and the Cal-Comp Plotter was well illustrated in the oral and written report and a work-

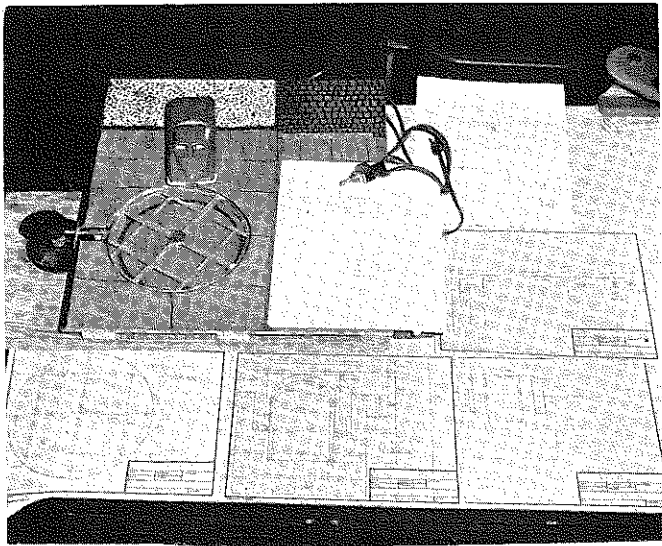

Figure 6

ing model. The problem selected was a design for an Acoustical Cone for an outdoor area or a high fidelity set. Certainly, the subject of acoustics is complex and well in advance of the scientific and technical ability of the freshman student, but in this project the design group was able to determine the correct curvature of the "cone" for the proper deflection of sound when produced in an area below the cone. The program was punched and fed into the computer with a multiple of variables. The deflections of the sound waves were then plotted on the Cal-Comp Plotter. The optimum deflection determined the desired curvature of the cone. Projects of this type illustrate how graphics can be coordinated with other disciplines and departments. See Figure 7.

Additional design projects, accomplished in the author's classes included such items as a Landing Area for a Helicopter Field, Fertilizer Spreader, Underwater Scooter, Anti-Skid Device, Transparency Stabilizer, Fall-Out Shelter, etc.

In the fall of 1969 the University of Texas at El Paso will offer a second semester course, following the basic graphics course, which will be Freshman Engineering Design. This type of course will further stimulate the student to use his knowledge of graphics in the engineering process.

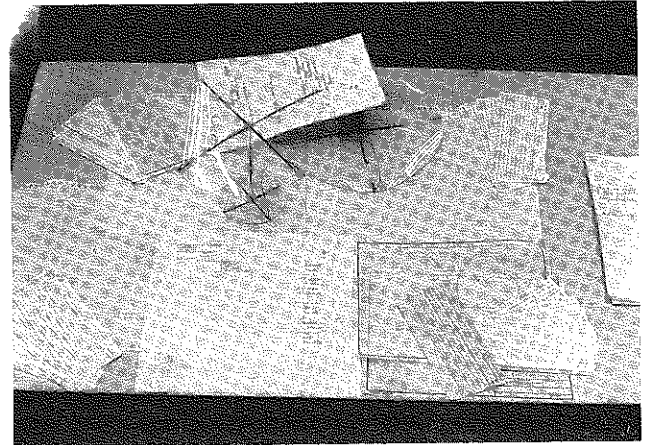

Figure 7

SUMMARY. By having a definite plan of organization and procedures, the graphics instructor will find that he has a controlled situation and can expect pleasing results. Both, an oral and typewritten report should be required from each group. The oral report should be given before an audience of fellow classmates, Engineering Faculty, and engineers from industry. The oral and written reports may be conducted as a contest with judges selected from industry. The instructor of graphics must not feel that a panel of judges is absolutely necessary. Enthusiasm and zeal can be attained by merely having a learned audience present from the engineering profession.

(Pictures by Otto Hans & Frawley)

=====

A LOOK BEYOND (continued from page 3)  
It would appear plausible that those teachers visited would welcome to get a first-hand account of the latest developments in Graphics Education in the United States.

Who would undertake a venture of this kind? Two situations which would make a journey feasible for an individual come to mind:  
1) Certain teachers may find such a venture a suitable condition for receiving sabbatical leave.  
Or 2) those among us who are successful proposal

writers may find it possible to take a leave of absence for this purpose with a grant to back them.

The information gathered in this way may not necessarily be useful in our specific individual efforts, but I refuse to believe that such an activity would not be a mutually beneficial enterprise. We would certainly all gain by this kind of exchange of ideas, if for no other reason than simply to be better informed teachers.



*A New Graphics Program!*

# THE ENGINEERING FUNDAMENTALS SERIES

Developed by  
Virginia Polytechnic Institute

The ENGINEERING FUNDAMENTALS SERIES is specifically designed for a sequence of instruction that integrates the traditional courses in Engineering Drawing and Descriptive Geometry. Problems in the books on graphics consist of both freehand and instrument drawings that help the engineering student understand the application of graphics to the engineering profession. All drawing pages are printed on white ledger paper.

## Graphics—Book I

Joseph B. Dent and W. George Devens  
Virginia Polytechnic Institute

*Graphics—Book One* presents the theory of orthographic projection in the study of points, lines, planes, and solids.

1968—\$3.25

## Graphics—Book II

Joseph B. Dent and W. George Devens  
Virginia Polytechnic Institute

*Graphics—Book II* continues the study of projection in pictorial forms—axonometric, oblique, and perspective—for additional projection theory and training in three dimensional space visualization.

1968—\$3.25

## Graphics—Book III

Joseph B. Dent and W. George Devens  
Virginia Polytechnic Institute

*Graphics—Book III* presents Descriptive Geometry through the application of basic projection principles to the solution of engineering problems.

1969—\$3.25

## An Introduction to Computers and Elementary Fortran—Book IV

Robert C. Heterick and James H. Sword  
Virginia Polytechnic Institute

*An Introduction to Computers and Elementary Fortran—Book IV* presents an overview of the computer and its use as an engineering or scientific tool. The language and machine specifications conform, in general, to computers of the IBM 360 series but may be adapted to others.

1969—\$3.25

## Notes on Graphical Calculus and Vector Analysis

D. H. Pletta and W. George Devens  
Virginia Polytechnic Institute

*Notes on Graphical Calculus and Vector Analysis* supplements text material used in the freshman engineering course. Topics covered include graphical calculus, vectors and vector algebra, and hyperbolic functions.

1969—\$1.25

WM. C. BROWN BOOK COMPANY  
*An Affiliate of*  
WM. C. BROWN COMPANY PUBLISHERS ♦ Dubuque, Iowa 52001





*An Integration of Engineering Drawing, Descriptive  
Geometry, and Engineering Problems Solution...*

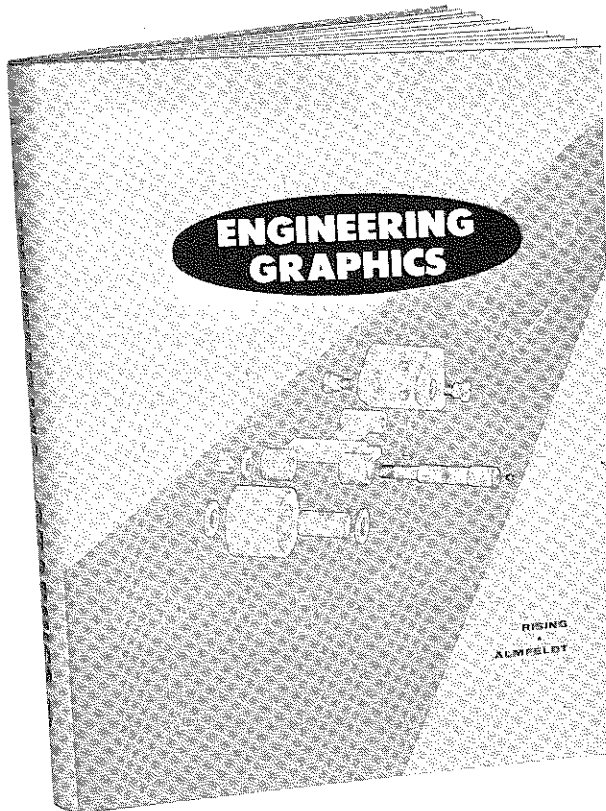

## ENGINEERING GRAPHICS, Third Edition

**James S. Rising and Maurice W. Almfeldt**  
Iowa State University

This text presents the basic principles and graphical theory of communication drawings in a logical and integrated manner. Innovations include the initial introduction of orthographic and multiview projection by the study of a point and its spatial location. Experience has shown that the student can better visualize the principles of projection applied to a point in space rather than to a solid with the complications of invisible edges and surfaces. The next logical step joins two *points* to form a *line*, with succeeding steps to develop basic theory of the *plane* and the *solid*.

Included are numerous illustrations and all appear on the same or facing page as the related text material. The third edition contains an enlarged unit on Production Dimensioning which includes ASA cylindrical parts; Z and N charts; and concurrency charts. Practice problems from the several fields of engineering illustrating principles previously discussed are presented at the end of each unit.

416 pp.—Cloth Bound—\$8.50

*Also Available*

### Problem Book I

**James S. Rising and Carl A. Arnbal**  
Iowa State University

This set of engineering graphics problems is keyed to the first 16 units of the text and is designed for a semester's work. Contained are 76 sheets of problems; layouts for practice of graphical theory, engineering applications and worded problems; and quality green tinted drawing paper for all problems.

\$3.95

### Problem Book II

**Maurice W. Almfeldt and Carl A. Arnbal**  
Iowa State University

This set of engineering graphics problems is keyed to units 17-37 of the text and is designed for a semester's work. This workbook contains 88 sheets of problems; graph paper in 10 x 10, log and semi-log for the graphical analyses found in units 33-37; and quality green tinted drawing paper for all problems.

\$4.95

**NOTE:** An answer key is available for those problems in Book I and Book II

**WM. C. BROWN BOOK COMPANY**

*An Affiliate of*

WM. C. BROWN COMPANY PUBLISHERS ♦ Dubuque, Iowa 52001



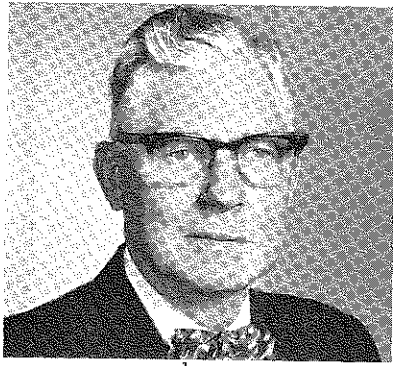

by  
Earl D. Black  
General Motors Institute

# USING THE TEAM APPROACH IN TEACHING ENGINEERING GRAPHICS and DESIGN

The trend in using design as a vehicle for teaching engineering graphics and its integration with other courses in engineering education raises several questions that should be considered. First, how can the fundamental principles be emphasized? How can creative design be taught effectively? How can individual student interest and a sense of responsibility be maintained? How can practical applications be used without monotonous stereotyped procedures? How can an atmosphere of reality be provided in class situations? How can student progress be evaluated? (and) Does the teacher need more or less time for preparation and teaching?

To explore these questions the author conducted an experiment over a three year period, 1965 to 1968, using the team approach in teaching graphics integrated with design, involving over 468 students in 24 individual classes. The classes averaged approximately 20 students who completed the beginning course from an average initial enrollment of slightly more than 21 students per class. The classes were divided into teams of three to five members, working together on design problems during laboratory sessions.

When measured by the final examination scores, given to all students taking the course, there is little measurable difference in knowledgeable facts attained by students involved in the team approach to learning. The true value of team organization within a class as is the intangible factors. Most students seem comfortable and interest runs high where design is used as a vehicle of instruction. A reduction of student absences and fewer freshman dropouts add weight in favor of the team approach.

## CLASS ORGANIZATION

It was apparent, from past experience, that classes vary in individual previous training and ability. Therefore, a diagnostic test

was designed and validated to determine the starting point of all students in each class in order to make a more accurate comparison and conclusion. This test consisted of four pages and was given to all students during the first hour of the first laboratory session. Diagnostic scores were recorded individually for later comparison of progress in grade attainment.

The diagnostic test consisted of 8 problems in form comparison, 14 problems in matching pictorial drawings with corresponding multiviews of objects, and 12 line-completion drawings which included primary auxiliary and sectional views.

By the end of the second laboratory session, students were assigned to teams of which at least one student had attained an average or above average diagnostic test score. Students from the same sponsoring GM Division were also assigned to different teams. Team group leaders were determined by two methods. At the beginning of the experiment they were selected on the basis of the diagnostic test score. Later they were selected by the team group and were changed at the end of each six weeks to give more students practice in coordinating team projects.

## TEAMWORK

Teamwork means joint action by a group. Teamwork is a necessity in our lives, and especially in American industry. In most laboratory instruction it is difficult to prevent more or less unorganized teamwork. This usually consists of two or three buddies getting together and making comparisons of individual work performances. If another student proposes an idea that is better than his own, he is likely to change his own approach. The change can either broaden his experience or throw him into a state of semi-confusion.

Casual teamwork is also obvious when three or four students congregate around another who automatically becomes a leader. Such an unorganized group often gets noisy and disturbs others around them.

Organization of teams should minimize confusion by established rules of operation. The work area assigned to individuals should be convenient to the team group. Problem assignments should be selected to require working together but should also require individual performance on a given unit. Open-end design problems should have more than one satisfactory answer, but should have an objective of proper function with simplicity and economical processes. Each team member should be required to do his share of work involved. Detailing should be divided into even work loads. Each student should be able to answer any question directed to his team.

There is an old saying "It is by our mistakes that we learn." Each team member can make sketches of his own ideas and then discuss them with the others. In this way he will develop in ability to analyze and reconstruct design requirements and get practice in communicating his ideas man to man. He should develop in ability to determine where he has erred or help others to see where they have made mistakes. By comparing ideas, mistakes can be corrected before they are incorporated in the design and before it is finalized. Added experience is gained by the exchange of ideas with others.

Working by teams can also be a help to the timid student who hesitates to ask questions of the teacher. It provides a supervised and ethical means of discussion among students that can be organized with some control. The team approach also gives the student experience in the give and take that is needed when working with others. Furthermore, added interest tends to motivate the student and has helped to reduce the attrition rate of students who drop out of school. It develops a sense of responsibility through the distribution of the work involved.

Of course there are some disadvantages in the team approach that should be carefully considered. Some students may overdepend upon the others of his team. The teacher should carefully check group discussions, not only to provide a sense of direction, but to give proper supervision. The group leader often develops a possessive attitude and an extra measure of responsibility rather than limit himself to coordinate activities, thus antagonizing his fellow team members. Also, a few better students may feel that the slower student is a drag on individual progress. These students may react negatively to the team approach. Too, a group

discussion can easily be turned to subjects foreign to the problem assignment. The teacher should make it a point to check such conditions and take measures to correct any irregularities

## GRADE ATTAINMENT COMPARISONS

Figures 1, 2, and 3 show the results of the Diagnostic Test and a comparison of Actual Grades Attained by students participating in the experiment in three successive years.

Figure 1 shows that 10 students of 147 in the school year 1965-1966 began the course in Graphics for Engineers with a probability of failing. Yet the lowest final grade was 70, a passing grade without honor points. The diagnostic test score median for this group was 80, while the actual grade attainment median in the course was 86. Grade distribution ranged from 70 to 95. A slow start did appear to hold back the better students. In fact, 2 student diagnostic test scores indicated a capacity of 96 and 98 respectively. Class size averaged 18.3 for 8 classes participating in the experiment.

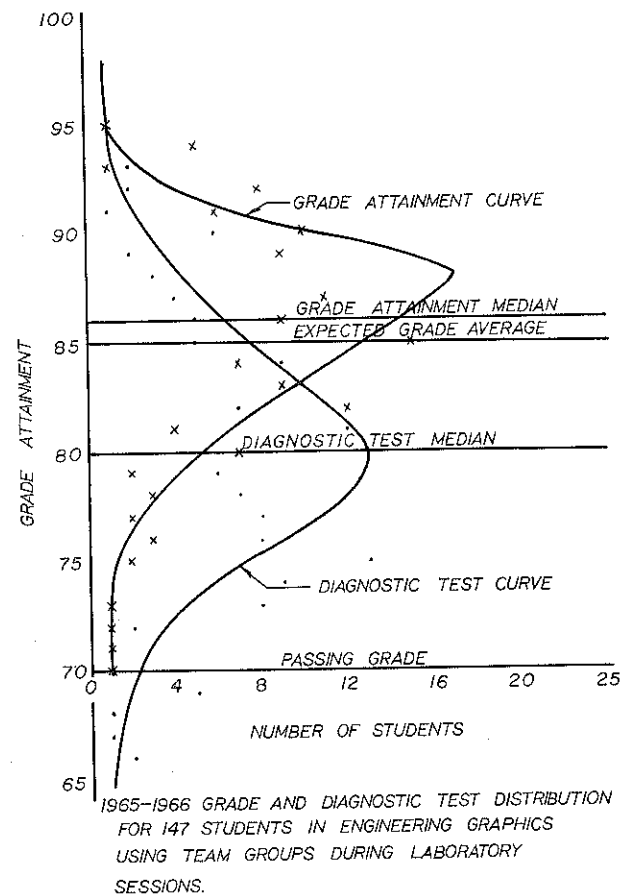
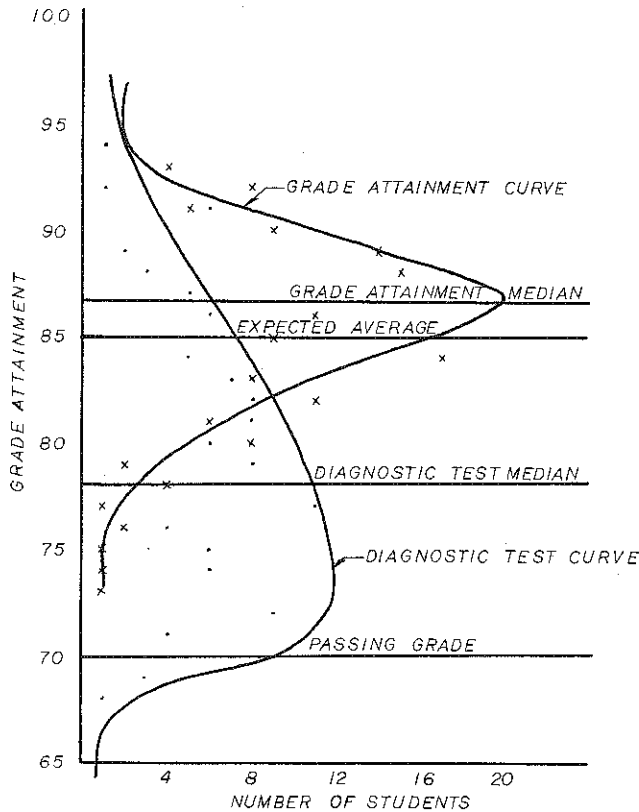

Fig. 1

Figure 2 shows the grade attainment and

Diagnostic Test Score distribution curve for 162 students participating in the experiment during the school year 1966-1967. The diagnostic test scores indicated 17 students beginning the course with a probability of failing. The class median for the diagnostic test score was 78 -- two points lower than the previous year. However, the median for actual grade attainment was 86.7 for the end of the course and the grade spread was from 73 to 97. The top grade potential and actual grade attainment was the same. Eight classes averaged slightly over 20 students per class.



1966-1967 GRADE CURVE FOR 162 STUDENTS IN ENGINEERING GRAPHICS WORKING IN TEAM GROUPS

Fig. 2

Figure 3 shows the Grade Attainment and Diagnostic Test Score distribution curve for 161 students in 8 Graphics for Engineers classes averaging slightly over 20 students per class. This group had 3 students who began the course with a probability of failure. There were only two failures. The low grade was 55 compared to a 58 probability. The high grade prediction was 98 compared to 96 probability. The diagnostic grade median was 82. The expected grade attainment median and actual grade earned median were both 85 for this year. The same diagnostic test was used for all classes.

#### STUDENT AND TEACHER REACTION

Students who were either appointed or

elected as group leaders were asked to write a report of their activities, reaction, and special problems which they face with the team approach. They were requested to be objective to list both the advantages and disadvantages of using the team approach.

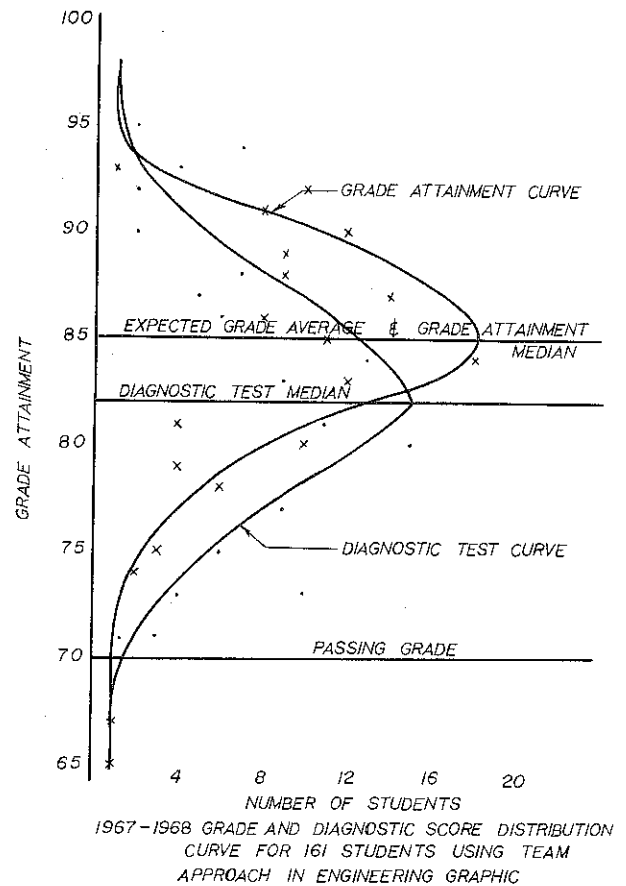

Fig. 3

#### STUDENT AND TEACHER REACTION

Students who were either appointed or elected as group leaders were asked to write a report of their activities, reaction, and special problems which they faced with the team approach. They were requested to be objective, to list both the advantages and disadvantages of using the team approach, and to hold their reports to a maximum of two pages. The following is taken from 65 student reports, and remarks are listed in the order of number of times mentioned.

All 65 group leaders expressed opinions of benefit to themselves for having had the experience of coordinating group assignments

Twenty-eight reports indicated that the group leader learned more trying to help others. Twenty-eight students also thought that they may have been of some assistance to the teacher in helping slower students with small details. Twenty-

three group leaders spent excessive time in coordinating team efforts and had difficulty in completing their own part of the assignment.

Twenty-one reports showed that the group team efforts gave students practice and developed skills in communication of ideas and problems between the "workforce" and "management". Twenty reports listed the idea that the group leader can be the main link between the teacher and individual students. Eighteen listed the development of a sense of responsibility to the group as a major benefit of using the team approach.

Twelve reports objected to the group leader having to spend more time studying in order to coordinate the work to be done. Eleven reports declared that the group approach provided experience in leadership, and nine reports recognized that poorer students got more individual attention using group methods of instruction. Nine reports listed the group method as providing organized cooperation among students.

Eight reports listed "the success of the group system depends upon a clear understanding of the group leader responsibility versus that of the other members of the team." Eight reports also listed having practice in coordinating the work of others as an advantage to the team group system, and eight listed the advantage of easily and quickly dispensing needed information among students in the class.

Seven reports expressed the idea that the team approach to learning provided the group leader numerous opportunities for reviewing subject coverage. Seven reports suggested that the group leaders helped to organize the class.

Six reported that the group approach tends to encourage cooperation as well as require coordination among the students of a team.

Five reports suggested that the group leader should be given detailed preliminary instruction in order to be of maximum effectiveness with the group, and five reported that students may depend too much on one or two others of the group to solve the problems to their own detriment.

Five reports expressed a satisfaction gained from being able to help others and indicated that this satisfaction more than made up for the extra time required. Five reports listed team organization within a class reduces petty questions about assignments, as well as promote better work on the part of most students.

Four reports indicated the approach requires more definite boundaries of operation. Four said a poorly chosen group leader can be a hinderance to the group

instead of an asset. Four reports gave the objection that group leaders lack experience in distributing assignments and organization of work to be done and can easily make errors where special attention should be given to students.

Four claimed the group leader often lacked the experience of others in his group. Yet four reports listed the team approach as offering the student, new to graphical methods, a sort of tutoring service as a point in favor of team groups within a class. Four reports listed "students learn to spot errors in the design stage before production tools and processes are begun," and four listed "the team tends to test the individuals within the group by the exchange of ideas."

Three reports suggested that the team approach helps students in budgeting time available, and that being a member of a team required working faster and more accurately on the part of all members of the team.

Three reports suggested that the evaluation of the coordinating on the part of the group leader and his extra work requirement is difficult, and three gave the objection of "the method for determining the group leader was inadequate," and further, that it can be difficult for the teacher to be sure that the group is being led "down the right alley."

Two reports stated that the team approach tends to reduce teacher involvement with students unless he gets "nosey," and students are reluctant to ask for help from a group leader who knows little more than they do. Answering stupid questions by other students wastes valuable time, was listed on two reports. Two indicated that some students resent the leadership of other students in the class as per two group leaders. The team approach tends to divide the class into distinct cliques, was claimed by two.

Working by teams sometimes twists and turns the simplest of problems to difficulty, said two reports, and the team approach was acceptable. At times, it was either too flexible or too rigid in operation, was listed by two other reports.

Two reports listed the team approach gives the shy student an easier way to find information by individual discussion on a student level. Two claimed that the team coordinator, usually being a better student, does not need as much time as others and has a profitable time in self-improvement in basic understanding and practice in communication. Two listed the team approach tends to relieve student tension where a large class makes it impractical to have constant contact between

the teacher and individual students.

Being a group leader requires that he be "on top" of each assignment, was claimed by two reports.

One report claimed that the team approach changes individual student status from one of nonentity to one of recognition and one claimed that the group approach tends to develop student independence even though they help each other.

## EVALUATION

Contrary to some student opinions, using the team approach does not reduce the student-teacher contact time with the alert and conscientious teacher. Nor does it reduce teacher preparation time. The class instruction time must be carefully prepared and presented in order to adequately emphasize fundamental principles to be learned. Creative design should be coincidental to instruction and encouraged as an opportunity for analysis and application of fundamental principles. The design processes can be used as a motivating device for increasing student interest with less monotonous and stereotyped procedures in teaching. The mere fact that students have a common problem in design provides an atmosphere of reality in class situations.

Student progress is evaluated in much the same manner as with conventional classes. A grade value for each student's performance can

be established on the basis of time requirements, complicity of the work, and the individual's quality performance. Project units can be classified as: easy, medium easy, medium difficult, and difficult. Grades should be recorded accordingly. The diagnostic test scores can be used to show the student's individual progress and expected performance.

The mere fact that a student is working on a common team problem, and his individual efforts contributes to the progress of the entire team achievement, develops a sense of responsibility, increases his interest, and promotes an increased effort on his part. He is usually desirous of making a good impression on his teammates as well as the teacher.

Final examination and grade achievement of individual students involved in the experiment indicates that creative design can be integrated in beginning engineering graphics courses, at least in limited portions, without reducing actual learning achievement in required factual knowledge and engineering principles normally expected.

The chief value and intangible factor of the experiment was the apparent happiness and enthusiasm of participating students in combining the team approach to instruction with a measure of creative design. A happy and interested student makes teaching easier.

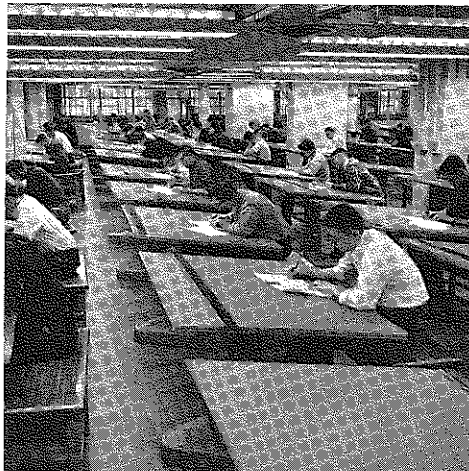

Designing At GMI



RIEFLER

Miracle Bow

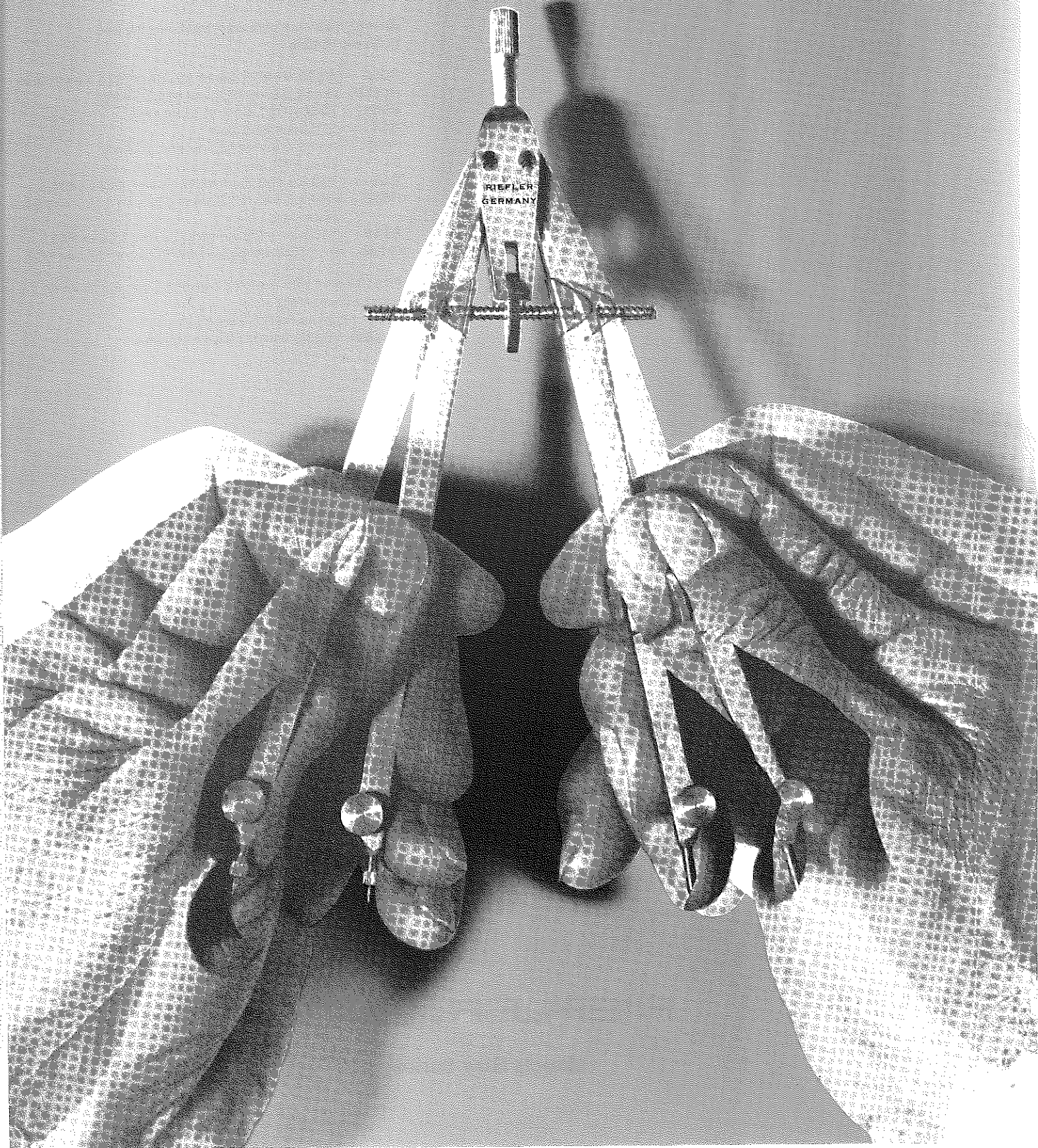



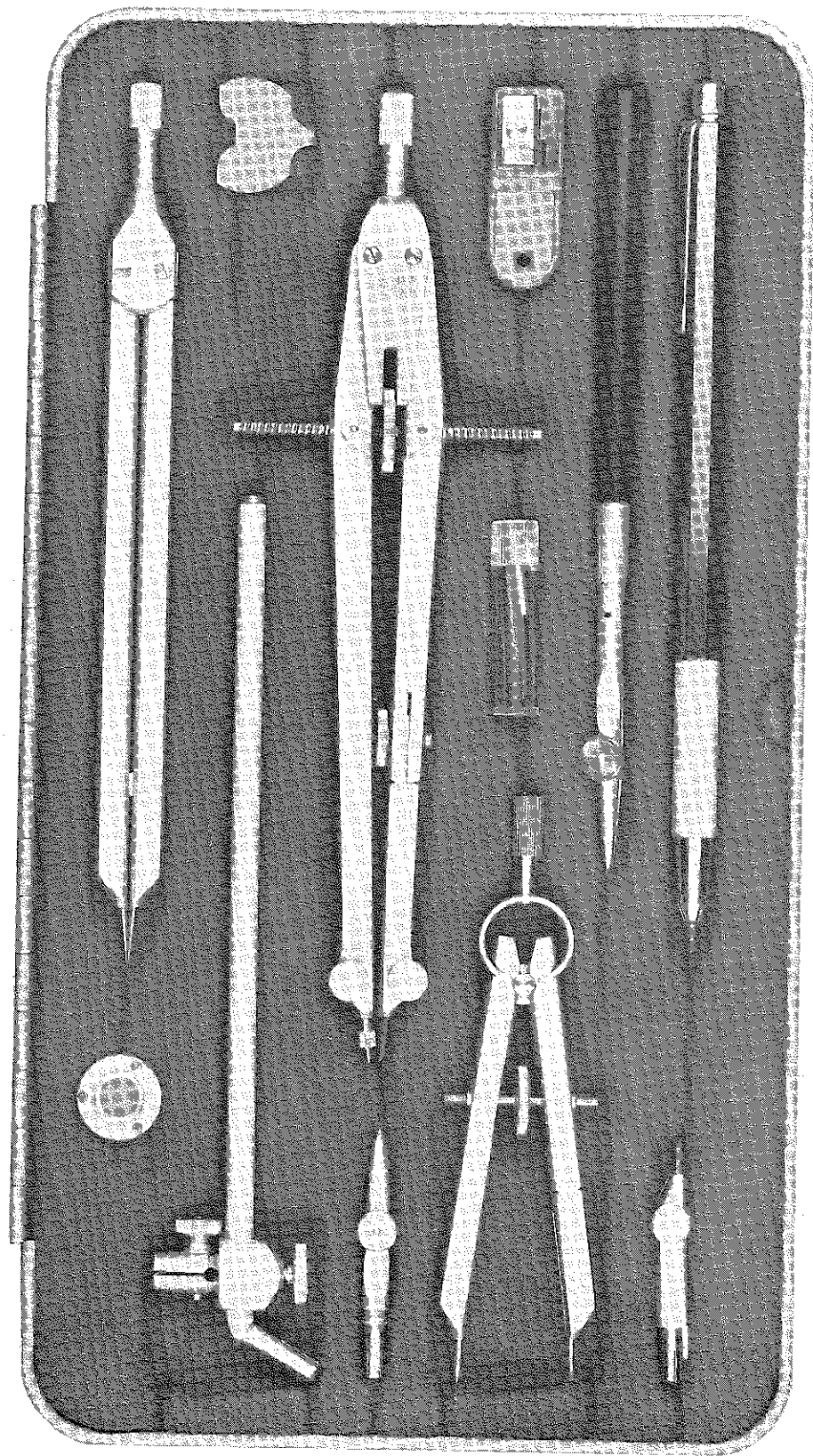

**Available Instruments and Set Combinations**

- R400** 6½" Miracle Bow fixed pencil
- R64** 6½" Miracle Bow with pen and pencil attachments and slip handle threaded needle point
- R64A** Same with lengthening bar
- R108** 6" divider
- R113** 4½" bow divider (not shown)
- R114** 4½" bow pen (not shown)
- R115** 4½" bow pencil (not shown)
- R113D/A** 4½" bow combination with pen, pencil and divider attachments
- R118** Drop bow (not shown)

**All Individual Instruments Attractively Packed in Plastic Sheath**

- R052** R400, R108 in plastic sheath or hard plastic case
- R052P** Same with mechanical pencil MC82
- R055** R400, R108, R115 in wood case
- R64** In hard plastic case
- R64P** Same with mechanical pencil MC82
- R1** R64, R108 slip handle in wood case
- R1A** R64A, R108 slip handle in hard plastic case
- R8AP** R64A, R108, R113D/A slip handle in metal case or wood case
- R8AP** Same plus Gramo-inker holder, 2 extra nibs,
- Gramo** 2 mechanical pencils MC82 in hard plastic case

All sets come with lead and needle boxes, screwdriver, and polishing cloth

Instruments are heavily chromium plated  
Available in satin finish or highly polished

**R8AP in metal case or wood case**  
Instruments heavily chromium plated  
Satin Finish or Highly Polished

**RIEFLER Gramercy**

**Miracle Bow Series**



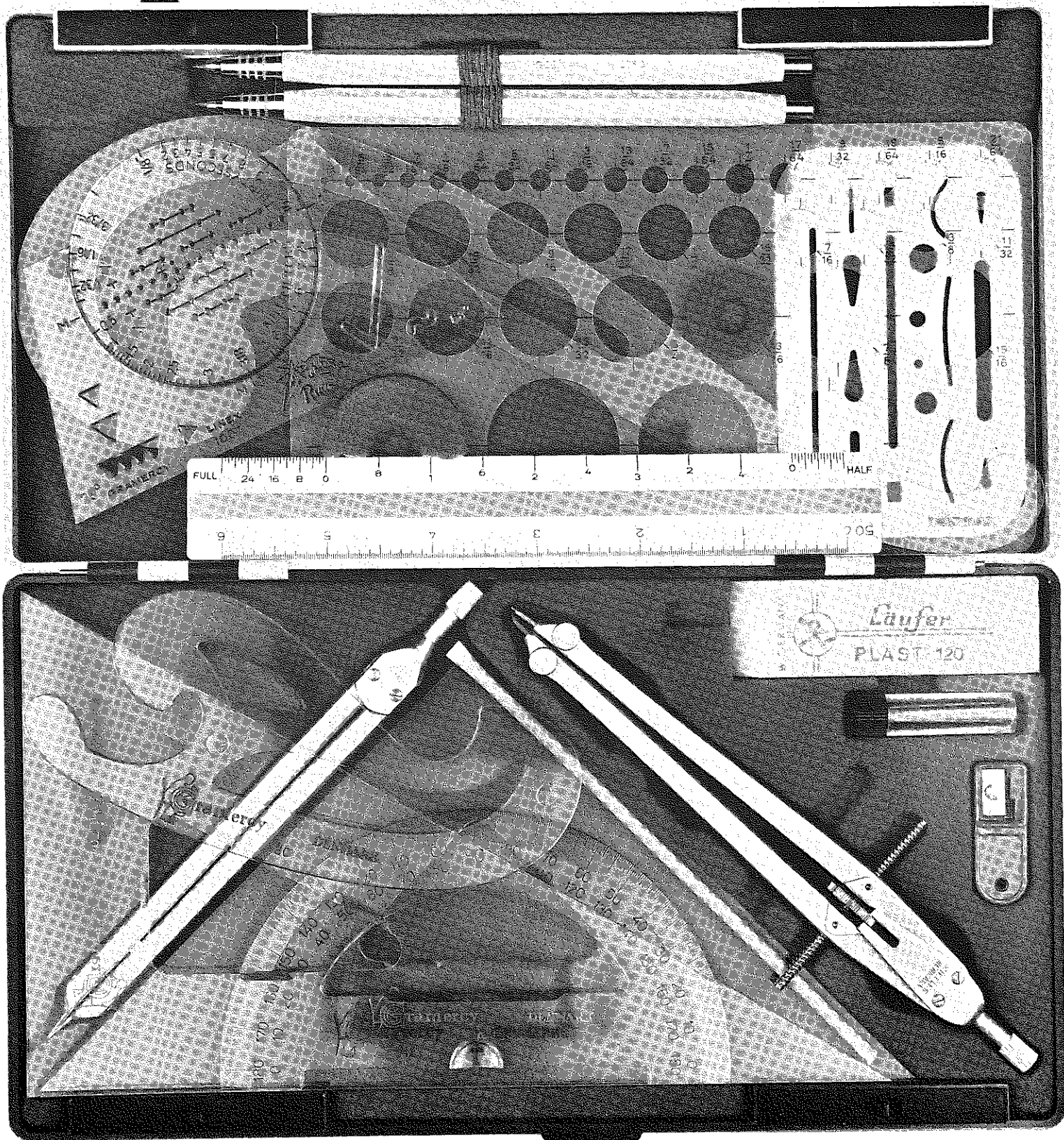

**R441 The Compact Drafting Kit**

Content:

R400, R108 acrylic triangles 45° 6" and 60° 8," protractor 180° 5," curves #80 and #82, metal erasing shield, 2 mechanical pencils MC82, 1 extra lead, leadpointer, circle template #1117, plastic eraser, lead and needlebox, special combination scale 6" with architects, civil, mechanical engineers divisions, engine divided—extra addition: lettering guide

Also Available:

R440—Same however R64 with pen part and slip handle instead R400 and eraser



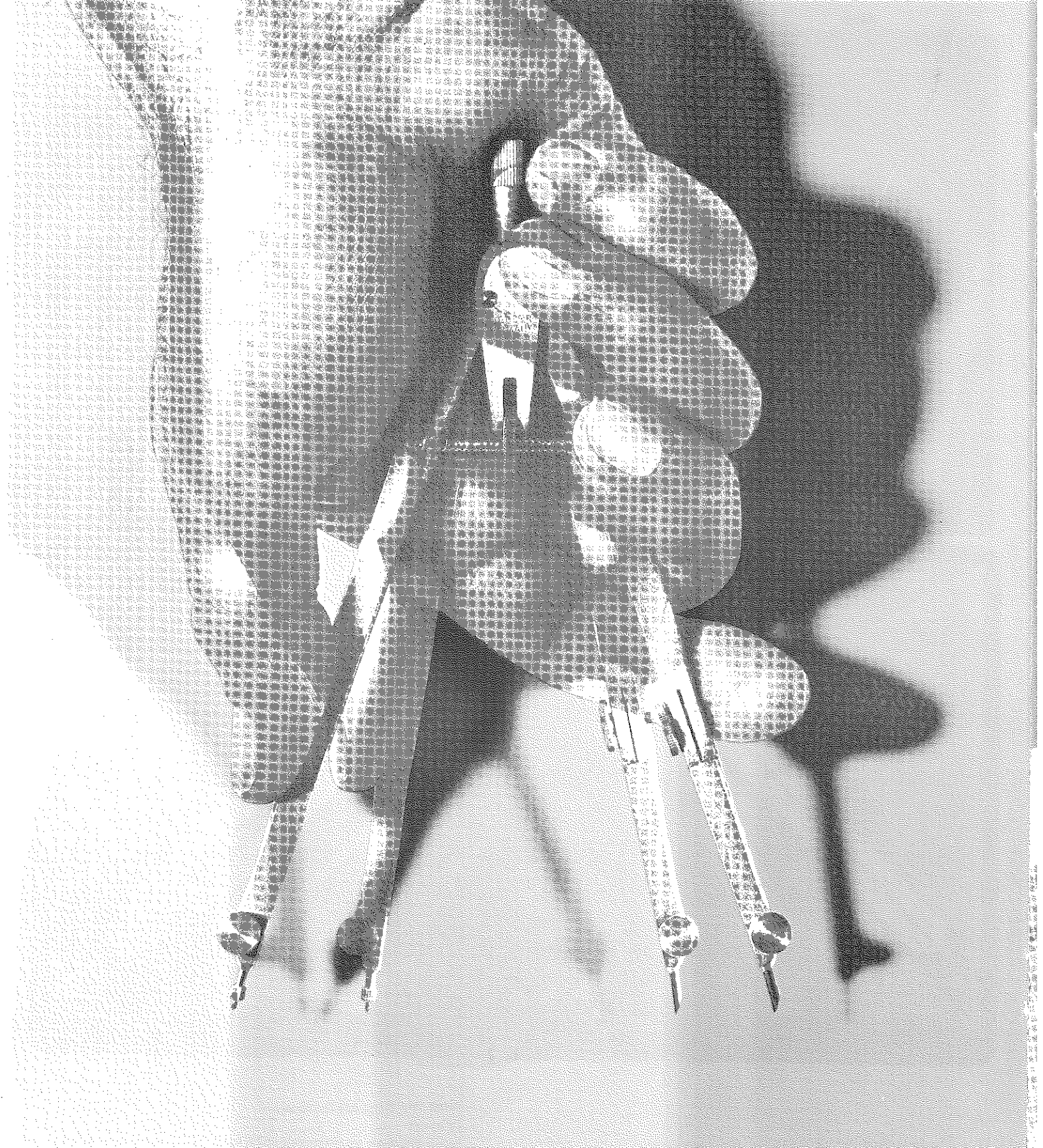

**“Push-Pull”  
The Animated Action Bow**

center screw used for fine adjustment only



# COMPUTER PRODUCED NOMOGRAPHS

by

Edward V. Mochel  
Associate Professor  
School of Engineering and Applied Science  
University of Virginia

This article describes a procedure for plotting functional scales. The procedure is valid only for single-valued functions, but a function with a double value could be plotted as two separate scales. The plotted scales may be aligned with appropriate geometry to produce nomographs. A parallel-scale nomograph can be produced directly. Other types could be put together by a paste-up technique or a refinement of the computer program. The procedure will not draw curved-line scales as presently written, but this is also a possible outgrowth of the program.

The procedure to draw the functional scales has nine parameters (XO, YO, VI, VF, INTL, INTT, MD, NDEC, and FUNCT).

The first two, XO and YO, are the x and y coordinates, in inches, of the left-hand end of the scale. The value of the variable which will appear at this point is VI (initial or left-hand value).

The next two parameters are the initial value (VI) and the final value (VF) of the variable. The initial value will appear on the left end of the scale and the final value will appear on the right end. Unfortunately there are certain restrictions on these parameters. They may be positive or negative, but cannot have more than 5 digits to the left or 5 digits to the right of the decimal place. These restrictions are imposed by the plotter software, as certain values will be labeled with numbers and the plotter package\* will only write numerical values within these ranges. The number of digits which will be printed is determined by the eighth parameter, NDEC. Also, either VI or VF may be zero.

This procedure which draws the functional scales is dependent upon the user for certain intelligence. It assumes that the user has made some calculations beforehand, and has selected such items as a scale modulus or a functional modulus. The parameters VI, VF, INTL, INTT and MD are interdependent, and cannot all be selected at random. More will be said about their relationship after each has been briefly

described.

The next two parameters are INTL (interval between labeled tick marks) and INTT (interval between adjacent tick marks). They must be in agreement with the previous two parameters, VI and VF, and in agreement with each other. For example, assume we are plotting a scale of R which will range from  $R = 1$  to  $R = 7$  ( $VI = 1$ ,  $VF = 7$ ). We could select an interval for tick marks of  $INTT = +2$  or  $+1$  or  $+5$  or  $+0.1$ , but we could not use an interval of  $+2.5$  or  $+0.9$  or  $+0.7$ .

The number of tick-mark intervals must be an integer, and is equal to the total range ( $7 - 1$ ) divided by  $INTT$ . Assume we let  $INTT = +0.05$  in this example. This would result in 120 spaces between tick marks ( $6/.05 = 120$ ) or 121 tick marks. See Figure 1(a).

Usually, we would not label each tick mark with a number, so we select a second interval (INTL) for labels. In our example, INTL could be  $+0.5$  or  $+0.1$  or  $+2.0$ , but again it could not be  $+0.7$  or  $+4.0$ . INTL must agree with the range ( $VF - VI$ ) so that the number of the labeled tick mark is also an integer. Furthermore, INTL must agree with the tick mark interval (INTT) so the ratio of these two ( $INTL/INTT$ ) is also an integer. This means that we can label every fourth or tenth tick mark, but cannot label every  $1\frac{1}{3}$ th or  $3\frac{1}{2}$ th tick mark. In the same example, if we choose  $INTT = +0.5$ , we could let  $INTL = +1.0$ . This means that every 20th tick mark ( $INTL/INTT = 1.00/.05 = 20$ ) would be labeled, and we could plot numbers 1, 2, 3, 4, 5, 6, and 7 on the scale. See Figure 1(a) for a plot of this scale.

In a non-linear scale, it is somewhat difficult to predict crowding of labeled tick marks, so the program only prints the numerical values when sufficient space is available. In crowded

---

\* The 0-0003 Calcomp Plotter package was used with ALGOL language on a Burroughs 5500 computer and a Calcomp 570 digital plotter in all this work.

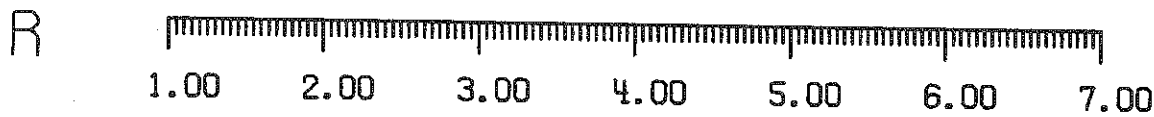

Figure 1(a)

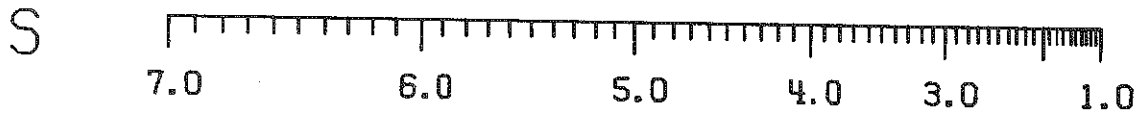

Figure 1(b)

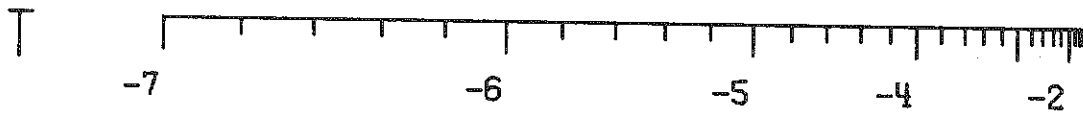

Figure 1(c)

conditions, some labels will be omitted.

The two parameters, INTT and INTL, must carry the same correct sign. If the values (from left to right) are increasing algebraically, then INTT and INTL must both be positive. In our example of VI=1 and VF=7, both INTT and INTL are positive. See Figure 1(a), where  $f(R) = R$ .

If VI=7 and VF=1, then both must be negative. See Figure 1(b). Also, if VI=-1 and VF=-7, then both must be negative. If VI=-7 and VF=-1, both should be positive as the values of the variable T are increasing to the right. See Figure 1(c), where  $f(T) = T^3$ .

Also, notice in Figures 1(b) and 1(c), some tick marks have not been labeled with a number. The program omitted the numbers to prevent crowding.

The next parameter (MD) is the functional modulus. This factor equates the length of the scale (L) to the range of values in the following formula:

$$L_n = MD [f(n)]$$

This gives the length ( $L_n$ ) in inches along the scale where the value N will be located (measured from  $L=0$ ). The total length of the scale, is therefore  $L_{total} = MD [f(VF) - f(VI)]$ .

Generally, for a 3-scale nomograph, the value of MD is chosen for two scales by selecting a range and an approximate length. The spacing between the scales, and the two moduli ( $MD_1$  and  $MD_2$ ) then determine the third modulus ( $MD_3$ ). In

any event, the computer does not select the modulus, and this information must be calculated by the individual and furnished to the computer. This particular program is written so that the modulus is always positive.

The eighth parameter, FUNCT, is the name of the procedure which describes the particular function which is being plotted. This procedure must be declared before the FSCALE procedure uses two procedures from the Calcomp plotter package 0-0003, and this plotter package must precede the FSCALE in the program. The two plotter procedures are PLOT (draws straight lines), and NUMBER (prints values of the variable to label axes). Generally, a third procedure of the plotter, SYMBOL, is also used, which can print the name of the variable (such as "R", "S", and "T") near the appropriate scale, and also to print a title.

Before FSCALE can be called on to begin the drawing, an origin must be established by the proper statement as described in the plotter package. For example, PLOT (0, 0, -5) was used in this program. After all the plotting is complete, a final statement, such as PLOT (20, 0, -3), is necessary.

Figure 2 shows a nomograph for the relationship between three variables, (X, Y, and Z) such that  $1.62X^{0.5} - 2.0Y^{4.61} = 0.25Z$ . This nomograph was drawn by inserting six cards into a deck which included the general procedure FSCALE, the plotter package and three small procedures. The six cards that drew this particular nomograph were:

FN1 ← 1.62 x ((XV) \* 0.50);  
 FN2 ← -2.0 x ((YV) \* 4.61);  
 FN3 ← 0.250 x ZV;  
 SCALE (10.0, 8.50, 0, 900, 100, 10, 0.20, 0, FN1);  
 FSCALE (10.0, 2.50, 2.00, 1.00, -0.20, -0.02, 0.20, 2, FN2);  
 FSCALE (9.88, 5.50, -200, 200, 50, 10, 0.10, 0, FN3);

The first three cards defined the particular function for each scale, and the last three called upon FSCALE to draw the scale, using the nine parameters discussed earlier.

Additional cards were added that put on such frills as labeling the axes X, Y, and Z, and adding the title. A complete listing of the program appears at the end of the article (Figure 3) except that the Calcomp plotter package is not listed.

The program contains two check points for errors. If the range of the values (VF - VI) is not divided into an integral number of spaces, the program will write "N IS NOT AN INTEGER" and stop running. The other check point is for length. If a modulus and a range of values is given that would produce a scale over 30 inches long, the program will write "SCALE IS OVER 30 INCHES" and stop running. This was added to prevent an error in the modulus (for example) from plotting a fantastically long scale. This could be by-passed by changing one card.

The array on card FS0230 has arbitrarily been set at 1000 elements. If a very long scale

were to be plotted which would include over 1000 tick marks, this number must be increased to some value greater than the number of tick marks.

All the cards which have FS numbers at the far right are part of the general program, and would remain in, regardless of the nomograph which was being drawn. The unnumbered cards are those specifically punched for this program. The program took 29 seconds processor time, 42 seconds I/O time, and about one minute to plot. The cost would be about \$1.75.

The necessary preliminary calculations and decisions which were made before the final three (FSCALE) cards were punched are shown briefly below:

$$\begin{aligned} \underline{X} \quad & f(x) = 1.62x^{0.5} \quad x \text{ range } 0 - 900 \\ & f(x) \text{ range } 0 - 48.8 \\ & \text{let } L_x = 10.0''; \text{ if } MD_x = .20, \text{ then } L_x = .2(48.8) = 9.76'' \\ \underline{Y} \quad & f(y) = -2.0y^{4.61} \quad y \text{ range } 2 \text{ to } 1 \\ & f(y) \text{ range } (-2.0) - (-48.8) = 46.8 \\ & \text{let } L_y = 10.0''; \text{ if } MD_y = 0.20, \text{ then } L_y = .2(46.8) = 9.36'' \\ \underline{Z} \quad & m_z = \frac{m_x m_y}{m_x + m_y} = \frac{.04}{4} = 0.10 \\ & f(x) \text{ range } -48.8 \text{ when } x=0, y=2 \\ & \quad \quad \quad 48.8 \text{ when } x=900, y=1 \\ & z \text{ range (approximately) } -200 \text{ to } 200 \\ & L_{-200} = -5.00'' \\ & L_{-195} = -4.88'' \\ & 5.00'' - 4.88'' = 0.12'' \end{aligned}$$

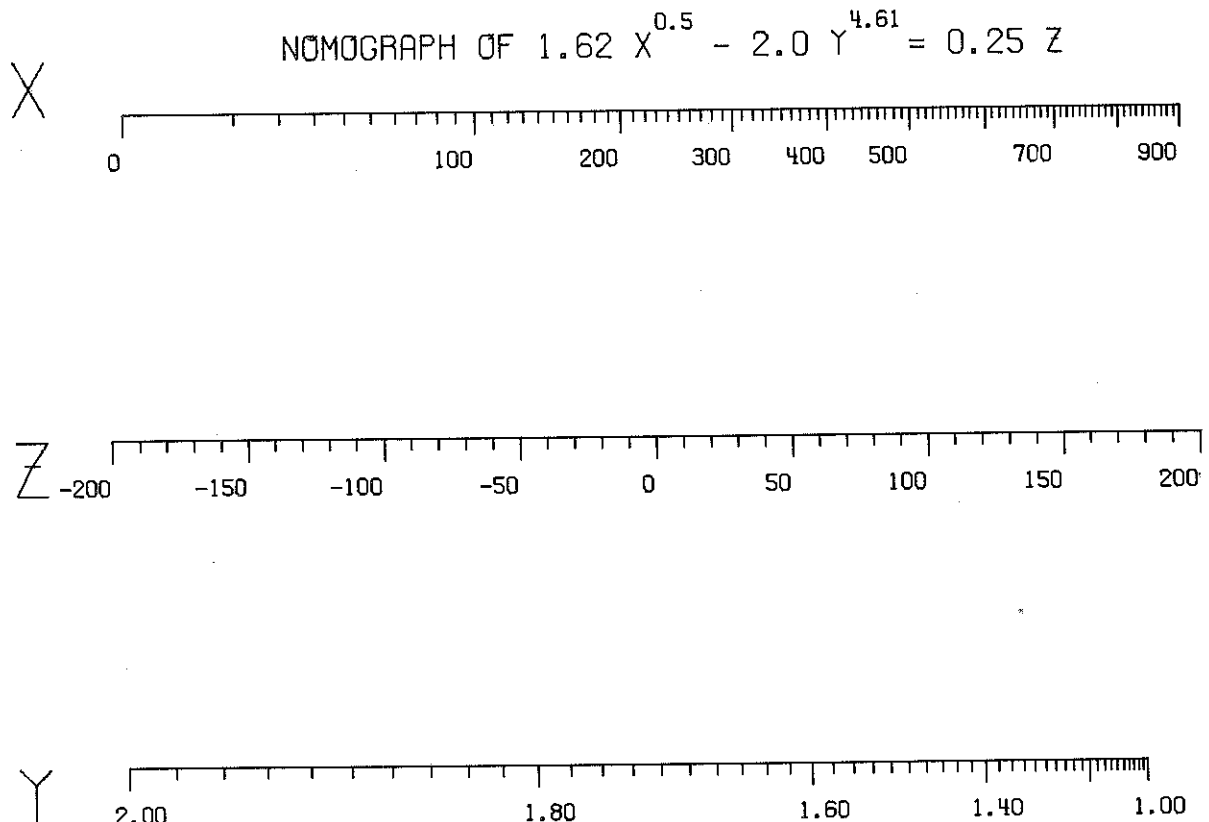

Figure 2

The author realizes that many readers use FORTRAN and languages other than ALGOL, and that this program, in its present form, may not be of immediate use. However, anyone with some programming experience and an interest in

preparing nomographs could probably readily convert it to his particular needs. If anyone has questions regarding it, the author would be glad to try and answer them.

```

BEGIN
COMMENT THIS PROGRAM PRODUCED FIGURE 2;
REAL XO, YO;
INTEGER I, J, N;
ALPHA ARRAY TL1[0:6], TL2[0:1], TL3[0:1], XL[0:1], YL[0:1], ZL[0:1];
REAL PROCEDURE FN1(XV);
VALUE XV;
REAL XV;
BEGIN
FN1 ← 1.62 × ((XV)+0.50);
END OF FN1;
REAL PROCEDURE FN2(YV);
VALUE YV;
REAL YV;
BEGIN
FN2 ← -2.0 × ((YV)+ 4.61);
END OF FN2;
REAL PROCEDURE FN3(ZV);
VALUE ZV;
REAL ZV;
BEGIN
FN3 ← 0.250 × ZV;
END OF FN3;
PLOT( 0.0, 0.0, -5);
FILL XL[*] WITH "X ";
FILL YL[*] WITH "Y ";
FILL ZL[*] WITH "Z ";
FILL TL1[*] WITH "NOMOGR", "APH OF", " 1.62 ", "X - ", "2.0 Y ",
" = 0.", "25 Z ";
FILL TL2[*] WITH "0.5 ";
FILL TL3[*] WITH "4.61 ";
BEGIN
PROCEDURE FSCALE( XO, YO, VI, VF, INTL, INTT, MD, NDEC, FUNCT);
VALUE XO, YO, VI, VF, INTL, INTT, MD, NDEC;
REAL XO, YO, VI, VF, INTL, INTT, MD;
INTEGER NDEC;
REAL PROCEDURE FUNCT;
BEGIN
REAL AR, INL, L, RF, RTO, WD, XV, YDL, YDT;
INTEGER I, J, NL, NT;
REAL ARRAY X[0:1000];
LABEL LA, LB, LE, LF, LG, LH, LN, LR, LT, LU, LEE, LGG;
COMMENT ONLY USE THIS PROCEDURE AFTER AN ORIGIN HAS BEEN ESTABLISHED
AND AFTER THE PROCEDURE FUNCT HAS BEEN DEFINED;
FORMAT ORANG("VALUES OUTSIDE RANGE OF THIS PROGRAM"), ER("N IS NOT
AN INTEGER"), LEN( "SCALE IS LONGER THAN 30 INCHES");
IF VI = 0 THEN GO TO LB;
IF ABS(VI) ≥ 100000 THEN GO TO LGG;
IF ABS(VI) < 0.00001 THEN GO TO LGG;
IF VF = 0 THEN GO TO LF;
LB: IF ABS(VF) ≥ 100000 THEN GO TO LGG;
IF ABS(VF) < 0.00001 THEN GO TO LGG;
GO TO LF;
LGG: WRITE( LP, ORANG);
GO TO LH;
LF: AR ← ABS(VF - VI);
RF ← FUNCT(VF) - FUNCT(VI);
YDL ← YO - 0.20;
YDT ← YO - 0.10;
L ← MD × (ABS(RF));
IF L ≤ 30.0 THEN GO TO LA;
WRITE( LP, LEN);

```

Figure 3

GO TO LH;	FS0340
LA: NL ← ABS( AR/INTL);	FS0350
NT ← ABS( AR/INTT);	FS0360
RTO ← NT/NL;	FS0370
INL ← (FUNCT(VI)) × MD;	FS0380
IF ENTIER(NL) = NL AND ENTIER(NT) = NT THEN GO TO LN;	FS0390
WRITE( LP, ER);	FS0410
GO TO LH;	FS0420
LN: FOR I ← 0 STEP 1 UNTIL NT DO BEGIN	FS0430
X[I] ← XO + ABS((( FUNCT(VI + (I × INTT))) × MD) - INL);	FS0440
PLOT( X[I], YO, +3);	FS0450
PLOT( X[I], YDT, +2);	FS0460
END;	FS0470
PLOT( X[INT], YO, +3);	FS0480
PLOT( XO, YO, +2);	FS0490
PLOT( XO, YDL, +2);	FS0495
WD ← 0.72 + (NDEC × 0.12);	FS0500
NUMBER( XO = 0.72 , YO = -0.50, 0.14, VI, 0.0, NDEC);	FS0510
J ← 0;	FS0520
FOR I ← RTO STEP RTO UNTIL NT DO BEGIN	FS0530
J ← J + RTO;	FS0540
PLOT( X[I], YO, +3);	FS0543
PLOT( X[I], YDL, +2);	FS0544
IF (X[I] - X[I - J]) < WD THEN GO TO LG;	FS0550
NUMBER( X[I] = -0.72, YO = -0.50, 0.14, VI + (I × INTT), 0.0, NDEC);	FS0560
J ← 0;	FS0580
LG: END;	FS0590
LH: END OF FSCALE ;	FS0600
SYMBOL( 11.50, 9.00, 0.21, TL1, 0.0, 40);	
SYMBOL( 14.92, 9.25, 0.14, TL2, 0.0, 3);	
SYMBOL( 16.72, 9.25, 0.14, TL3, 0.0, 4);	
SYMBOL( 9.00, 8.50, 0.49, XL, 0.0, 1);	
SYMBOL( 9.00, 2.00, 0.49, YL, 0.0, 1);	
SYMBOL( 9.00, 5.00, 0.49, ZL, 0.0, 1);	
FSCALE( 10.00, 8.50, 0, 900, 100, 10, 0.20, 0, FN1);	
FSCALE( 10.00, 2.50, 2.00, 1.00, -0.20, -0.02, 0.20, 2, FN2);	
FSCALE( 9.88, 5.50, -200, 200, 50, 10, 0.10, 0, FN3);	
PLOT( 20, 0, -3);	FS1010
END;	FS1020
END.	FS1030

Figure 3 (continued)



# WHAT A SCIENTIFIC COMPUTER CENTER CAN DO FOR THE ENGINEER

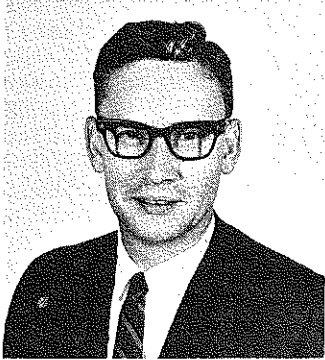

by  
J. B. VAIL and J. R. SANDLIN  
Radio Corporation of America  
Defense Electronics Products

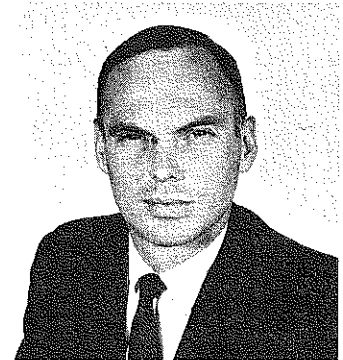

The computational services available to the engineer are many and varied; the typical Scientific Computer Center offers many services to aid in project accomplishment. In this paper, the counsel and assistance available for task definition are described and the procedures, capabilities and equipment complement of a Computer are explained. Guidelines for efficient use of the services are offered, and a look at future developments of interest to the engineer is presented.

---

The engineer requiring computational services today is faced with a bewildering array of choices. He has available to him equipment ranging from desk calculators, time sharing consoles, small general purpose computers up through large scale scientific facilities. Selections do not end with the hardware; software requirements must be defined, and computer programs appropriate for the task must be selected, modified or developed. Finally, efficient use must be made of the services available. Poor choices in any category can result in high expenses and delayed schedules in meeting the project goals; it is clear that an understanding of what is available plays a vital role in the probability of success.

## COMPUTER CENTER SERVICES

Possibly the most significant services available to the engineer user are those of the systems programming staff and program librarian. Training, data preparation and storage, provision of materials, the dispatching function, job set-up, priority service, and accounting procedures are other important services. Understanding these, and using them to their fullest, will be instrumental in the successful completion of the engineer's task.

## System Programming Staff

The members of the system programming staff are the experts on hardware and software aspects of the computers in the facility. They generally include at least one superior programmer with well-rounded experience in many programming languages and technical applications. His function, in addition to the maintenance and updating of the operating software systems, is to counsel the engineer on the choice of programming languages, use of similar programs/subroutines on file or available, and to suggest applicable programming techniques.

The systems programmer is also available to assist in "debugging" programs when in the checkout stage, and can help in interpreting error messages and suggest appropriate use of the diagnostic aids incorporated in the software systems.

## Program Librarian

The program librarian, usually a member of the systems programming staff, will have access to a large number of "application programs." These may have been prepared at the center and entered in the program library or



they may have been obtained through various services and users groups. The center at M&SR, for example, has access to many thousands of programs via RCA's PAL (Program Applications Library), SHARE (Society to Help Avoid Redundant Effort), The University of Georgia's COSMIC service, and Indiana University's Aerospace Research Applications Center. Many NASA and Department of Defense programs can be obtained. The program librarian has abstracts, indexes and program documentation; Fig. 1 is an example of a portion of a typical SHARE keyword index. Some programs are immediately available, while others may be ordered with two or three week delivery. Modifications are sometimes needed to satisfy specific requirements. It is frequently possible to identify programs which may be incorporated as "subroutines"; or portions of larger programs; time spent in researching available programs frequently results in considerable savings of time and money.

MAR 18, 1968		CAPR - KEYWORD PERMUTED INDEX	PAGE 9
*COSINE 1965 UDC* SINGLE PRECISION*HYPERCLIC*SINE	UDC	SC5H	
*COSINE *FLOATING-POINT*SINE AND	RC	ESCN	
*COSINE*TANGENT*CO*TANGENT *MULTI*PRECISION*SINE	PMT	2013	
*COST-ACCT*USAGE-ANAL *IMPROVED*OPERATIONS *ACCT SYS FOR*BILLING	JN	ACCT	
*COTANGENT 1963 *UDC*MODIFIER FOR SINGLE PRECISION*TANGENT *	UDC	ATAN	
*COTANGENT 1964 *UDC* SINGLE PRECISION*TANGENT *	UDC	INCF1	
*COTANGENT 1965 *MODIFIER FOR UDC*DOUBLE PRECISION*TANGENT	UDC	MDYN	
*COTANGENT 1965 UDC*DOUBLE PRECISION*TANGENT	UDC	DTAN	
*COTANGENT *MULTI*PRECISION*SINE*COSINE*ARGENT	PMT	2013	
*COVARIANCE MIXED MODEL *ANALYSIS*VARIANCE	BYU	ANDV	
*CRITICAL PATH ANALYSIS*OPERATIONS RESEARCH *PERT TIME	LR	LEGO	
*CRITICAL REGION*DECISION TABLES	RC	CR1X	
*CROSS-REFERENCE ASSEMBLY *ASSEMBLER*ASSEMBLY PROGRAM	NA3	NA3	
*CROSS-REFERENCES OF VARIABLES STATEMENT NUMBERS *FORTRAN IV	PK	ERRF	
*CRYSTALLOGRAPHIC*PRECISION DATA*INTENSITY TREATMENT	MI	XCIT	
*CRYSTALLOGRAPHIC*STATISTICAL TEST TO DETERMINE*SYMMETRY-CENTER	MI	CAS1	
*CURVE FITTING *BIVARIATE*ORTHOGONAL POLYNOMIAL*APPROXIMATION	TY	QBRT	
*CURVE-ROOT FOR DOUBLE-PRECISION FLOATING NUMBERS IN FORTRAN 2	TY	DQRT	
*CURVE DEFINED BY PARAMETRIC EQUATION *CALCULATE*POINTS OF A	IB	CURV	
*CURVE FIT OF SECOND DEGREE *MULTI*DIFFERENTIAL EQU. *LEAST-SQ.	AM	HDVA	
*CURVE FITTING ONE-DIMENSIONAL *RATIONAL*APPROXIMATION	ISA	RAPP	
*CURVE FITTING *BIVARIATE*ORTHOGONAL POLYNOMIAL*APPROXIMATION	ISA	P3LD	
*CURVE FITTING *GRAM POLYNOMIALS *LEAST SQUARES *POLYNOMIALS	RS	GRAM	
*CURVE FITTING *MULTIPLE REGRESSION *LINEAR*LEAST-SQUARES	IN	7210	
*CURVE *SMOOTH ROUTINE FOR 7090/7094 NINE POINT *PARABOLIC	MA	DSM3	
*CURVE FITTING *ORTHOGONAL POLYNOMIALS *LEAST SQUARES, WEIGHTED	RH	CF	
*CURVE FITTING WITH CONSTRAINTS *SINGLE-PRECISION*LEAST-SQUARES	ASB	DJ06	
*CURVE FITTING *CHEBYSHEV*APPROXIMATION*EXCHANGE METHOD	HA	O11	
*CUTTING STOCK PROGRAM *TWO-STAGE*TWO-DIMENSIONAL*TRIM CR	PK	TR2D	
*CYCLE*ANALYSIS*ATIONAL BUREAU METHOD BUSINESS	UC	BCA	
*CYLINDER ANALYSIS	WH	CAN	
*DATA ANALYSIS MODEL ELASTOMER *RUBBER *GMPD *VISCOELASTIC*IMPACT	SE	DAMP	
*DATA READING *STANDARD PROGRAM FOR	SN	PSLD	
*DATA-CONVERSION STATEMENT *ENCODE*DECODE *FORTRAN*MEMORY-TO-MEMORY	JP	FED	
*DATAPLOTTER SUBR PACKAGE FOR CREATING*PLOT TAPES FOR THE*EAI	CO	PLTP	
*DATE FOR PRINTING BY THE MAIN PROGRAM PICKS UP THE	MAU	KA	
*DATE FROM *IBMC RUN	PKA	DATE	
*DEBUGGING BY PRINTOUT OF REGISTERS AND TRACEBACK THRU*SUBPROGS	CUP	ETRC	
*DEBUGGING BY SELECTIVE*MEMORY*DUMPING DURING EXECUTION *DYNAMIC	NS	SNPP	
*DEBUGGING BY SELECTIVE*MEMORY*DUMPING DURING EXECUTION *DYNAMIC	NS	SNPM	

Figure 1  
Portion of a typical SHARE keyword index.

The program librarian also keeps various manuals and instructional material on file, these are available on request and will be updated as addendum documentation is received. He is also responsible for maintaining current reference material in the customer service area.

Many general purpose subroutines are available to solve specific functions, manipulate data, generate random numbers, etc. These are, in general, packages that could be inserted in the engineer's program, thus saving him the effort of coding and testing that segment.

## Training

Computer languages are dynamic in nature

and enhancements are continuously being made. This prompts many installations to conduct frequent training courses in the currently popular problem-oriented computer languages (such as Fortran, Cobol) and machine-dependent assembly languages. The advent of third generation computers will call for more special training courses, particularly in the area of random-access storage techniques. During or after hours courses are taught on a regular schedule or whenever a sufficient number of individuals are interested; sample problems are included as part of the course. RCA's Continuing Engineering Education program offers four courses of specific value to the engineer user of computer services.

## Data Preparation

Most computer centers maintain large data preparation groups to keypunch production jobs for subsequent computer processing. Additionally, many centers set aside a number of keypunch machines for the exclusive use of the engineer. Large jobs are generally processed and verified by skilled operators, but the engineer will frequently prepare a few cards to minimize turn-around time.

## Information Storage

A major service supplied by the Computer Center is temporary use of magnetic storage media such as discs or magnetic tapes. The engineer is allowed to use and save a reasonable number for his job. The Tape Library will allow storing and retrieval of magnetic tape data for a predetermined time. Computer costs and run time may be directly related to the quality of the magnetic tapes used by the facility. The Tape library will often have the capability to clean, repair, and validate magnetic tapes on site. Cards and other necessary material may be stored in assigned locations.

## Processing the Job

The engineer's program and data will be handled by many people and, most likely, processed by many machines before the final results are returned. The process of controlling the flow of data, collecting and coordinating the various operations and using the output is the task of the site dispatcher. Additional dispatcher duties include checking the data for correct control cards, monitoring the progress of the job, and insuring appropriate disposition of the results.

## Computer Applications Group

Once the engineer has developed a working system of programs he may wish to shift to

shift the task of collecting data and submitting computer runs to the set-up or application group. These personnel are familiar with the operation of the data processing activity and can, with the aid of the engineer's instruction, perform the routine data handling functions, telephone coordination, and mail submission/delivery to minimize effort of the engineer.

### Priority Assignments

Many centers categorize computer runs into groups by language used, computer run times and complexity of equipment configuration. When a large group of runs satisfy a category requirement an "express service" will generally be established to give rapid turnaround and efficient operation. Similar runs are placed in batches for sequential processing; there may be four or five express runs daily and, if properly used, can be very helpful in meeting work schedules. Other runs will be interspersed with express service, although long runs, or those requiring extensive tape mounting and removal, will be held for night shift processing. The center will usually recognize reasonable justification and take appropriate steps to insure priority processing when needed; this is normally coordinated through the computer operations supervision.

### Accounting

Every engineer is, as a rule, working with a budgeted amount of money; thus it is important that he be aware how much has been spent and what balance remains. When an account is opened the current billing rates for equipment usage are given and an estimate of services to be provided, made. Every job that is processed requires a job submittal form which is returned to the user. This form contains, in addition to operator comments, the time actually used to process. Charging practices vary between centers; some include job set-up as well as actual running time and may charge full rates for "peripheral" operations (card to tape transcription, printing of output).



The CAL-COMP plotter at the M&SR Division computational center.

Most centers bill only for program running time and have proportionally lower rates for peripheral operations. Many centers prepare a computerized weekly report that presents a complete history of each task; who worked on the submissions, how long, what machines were used, how many minutes, what were the costs for each category, what was the total cost, etc. A similar report is processed monthly and used for customer billing purposes. These reports are available to the engineer for review, question, or comment.

## COMPUTER CENTER EQUIPMENTS

### Large Computers

The large scale computers have high speed, large capacity data storage, many medium-speed (magnetic tapes and discs) units, and sophisticated software operating systems. This type of computer is extremely desirable for the solution of scientific and engineering problems. Large matrices, complex formulae, intricate data manipulations, and various simulation techniques are particularly adapted to the large computer.

### Small Computers

Most small computers have limited high-speed memory capability but do have high-speed card readers/punches and printers. The small computers are extremely useful for performing utility functions, such as transcribing cards to tape, printing, duplicating magnetic tapes, and editing data, at lower cost.

### Auxiliary Equipment

Auxiliary equipment include devices in the category of data preparation. Key punch and paper-tape punches are a way of transferring data from a source document to a media acceptable to a computer-reading device. This media may be punched card, punched paper-tape or coded magnetic tape.

Some examples of special purpose data preparation devices would include the Oscilloscope Trace Reader (OSCAR) which generates punched cards from analog charts under operator control; the Digital Film Reader (BOSCAR) generates punched data cards of film-coordinate data under operator control; and the Programmable Film Reader (PFR) which produces magnetic tape under automatic control of a programmed computer film scanner. Special purpose devices are a part of many centers, and include those capable of digitizing radar video data, speech data, etc.

There is a class of data handling equipment

commonly referred to as EAM (Electronics Accounting Machines) designed to process punched cards. These devices, although significantly slower than computers, perform the task of sorting, merging, reproducing, or printing small volumes of data at a reasonable cost. They are especially useful in duplicating program decks, listing programs for modification and manipulating data on cards.

Many times the engineer will develop computed data in tabular form whereas it might be more meaningful to subsequent use in some pictorial form, such as a plot. Most large computer centers have digital plotters on-site which will accept magnetic tape directly, thus generating the final desired output. These plotters operate in conjunction with program subroutines to allow scale changes, axis rotation, three-dimensional effects and automatic pen selections.

Center supporting equipment will include decollators (for separating multiple-part printed output), bursters (for separating pages), microfilm viewers and other miscellaneous equipment.

### Software Selection

Software (the instructions to the computer) is generally the major expense item, as well as the pacing schedule factor in accomplishing engineering computational tasks. The computer center can provide a wide spectrum of support to minimize cost and schedule impact; to do so the following actions must be accomplished by the engineer and center personnel:

- 1) Adequately defined computational requirements.
- 2) Survey available programs for one suitable in its original form or adaptable with modifications.
- 3) Determine if the engineer will prepare all or part of the required software. Select programming language, obtain necessary instruction and literature.
- 4) Define software requiring development by a professional programmer.
- 5) Determine software documentation required.

Definition of computational requirements is best done at the beginning level on a "question and answer" basis with center personnel. The three basic questions are:

- What is the output data format and characteristic?
- What are the logic and equations needed for computation?
- What is the required output format and method of presentation?

These must be answered precisely to allow proper software support. Following definition of the required software, the program library is checked for the programs or subroutines which could be utilized advantageously.

Many engineering problems can best be solved by the engineer himself, particularly if he possesses some skill in Fortran or similar language. It is relatively easy to break out well defined portions for a professional programmer. This is advantageous if machine-level language is necessary for involved logic data manipulation or if complex computer-oriented numerical analysis methods are needed. Present operating systems have features which allow relatively straight-forward interface between program segments, even if written in different languages.

Center personnel can arrange for programming instruction and supporting manuals. Should the application warrant the learning process, there are a number of "problem-oriented" application systems languages available which are sometimes simpler and more applicable to specific tasks. These include ECAP and SCEPTRE (for electronic circuit analysis), LOGSIM, GPSS and SIMSCRIPT (for numerically controlled machine tool tape preparation), ROCKET (for space trajectory studies), and others. Well written user manuals are usually available for them.

When professional programming is required, specific definition is necessary. In most Centers, a "specification" is prepared by the user, a "program plan" by the programmer and necessary reviews are held by the user and Center supervision to insure satisfactory development and schedules. The depth of detail included is in proportion to task complexity; effort spent in complete definition is directly related to the success of the overall effort.

The type and extent of software documentation required should be established early in the task. It may range from only the information necessary for the computer run submittal to detailed operating procedures, data preparation instructions, flow charts and details of the logic and mathematics used in the program. Center personnel will assist in defining and selecting documentation required. Documentation criteria are based on the anticipated life of the program, who will accomplish data preparation and run submission, the possibility of later modification and utility of the program for other users. Professional recognition and savings for others can be obtained by submittal of the finished program and documentation to the center program library or the many program exchange services.

The software support available from a scientific computer center is extensive and one may realize large cost and schedule savings through efficient use of the services which can be provided.

### Task Initiation

The engineer's first action in initiation of his task should be the seeking of advice from qualified individuals. Each computer facility has one or more "contact men" who are willing and capable of providing information on equipment, software, procedures and cost. Of great benefit to the engineer is counsel on how best to approach his problem. A key element in arriving at the ultimate approach is task definition; the format and characteristics of input data, the logic and equations of computations required, and the presentation of output. Having surveyed the task definition, the "contact man" will refer the engineer to specialists for information on available software, estimates of programming effort, data translation services, applicable manuals, ect. At this point, it is imperative that the engineer answer several questions:

- 1) Is this the proper facility to use for my job?
- 2) Has all currently available software of potential use been surveyed?
- 3) Is it advantageous to use professional programming assistance for all or part of my job?
- 4) Should I prepare and submit computer runs myself or use facility personnel for assistance?
- 5) What is the cost and schedule I can reasonably expect for accomplishing my task?

Definitive answers to the above questions should be obtained before proceeding. The task complexity obviously affects the time and effort required; it is all too easy for the beginner (as well as experienced) user to embark on a major task with inadequate definition. The invariable result is an expensive and time-consuming iteration to recover.

Following complete task definition and after the decision to proceed has been made, necessary funding and scope of work are authorized to the computer center and detailed arrangements are made (it is useful that the engineer obtain and study copies of the center's user procedures for job submittal, data retention, priority service, etc. before job submittal begins). Proper task initiation is the major factor in successful accomplishment; the benefit from expenditure of modest effort in this aspect cannot be overemphasized.

### Using The Facility

Following task definition and software selection, use of the physical facilities begins. Many centers assign a user code or number, both for data identification and charging purposes. The services of the center are then at the engineer's disposal. Card or tape punching involved in data or program deck preparation may be performed by the engineer or, at his option, submitted to the center's data preparation staff. Translation of data (extraction of information from charts, worksheets, etc.) may also be accomplished by center personnel.

Submittal of computer runs is performed at the dispatch desk, where the user code is verified, control cards are checked, and the job logged. The job is then assigned to one of three general categories: express, normal production, or night production.

The job submittal form requires information necessary to establish the category (estimated running time, program input/output unit assignments, language, operating system, and any special operator instructions) as well as user code and "force time". This latter entry is to indicate the maximum running time, and is for the protection of the user. It is particularly valuable during debugging of a program when inadvertent "loops" may be entered which could cycle program steps indefinitely without normal job termination.

The engineer may obtain estimated completion time from the dispatcher when his job is submitted or request that he be called when his output is ready. Requests for priority treatment are normally directed to computer operations supervision and will be honored whenever possible without causing undue impact on other users. At job completion, input and output data are placed in the issuing area, generally alphabetically or by user code, and "save" tapes are placed in the tape library. The job submittal form is returned to the engineer with the running time and operator comments noted.

Problems are frequently found in the results, particularly in the beginning stages of a task. These should always be resolved, and extensive help is available to do so. The systems programmer is normally the starting point and he will determine whether a programming, operations, or data error occurred. He will give counsel to help resolve programming problems, and offer suggestions to improve efficiency. His explanation of system diagnostics, reading program dumps, and alternate debugging aids will be of value. Indicative of non-programming errors to be expected at M&SR's center

on a routine data reduction task involving some 1500 runs over a six-month period (stated as percentage of total runs);

Operations (operator, machine, software, systems)	7.1%
Job submittal (parameter card, erroneous instruction)	6.5%
Input data (data identification, format, recording errors)	9.8%

Each of the above large-scale computer runs involved card-to-tape and multiple-output printing. Some 400 to 600 individual operations per day are typical in a large-scale computer center and problems are not unknown.

Time lost due to operations errors is normally not charged to the user and most centers employ a "problem report" to assist in resolving troubles. Center supervision should be contacted when unresolved problems occur; this is a vital part of the feedback process to improve service.

#### OBSERVATIONS ON SERVING THE ENGINEER USER

A wide spectrum of use and success is noted in serving the engineer at scientific computer centers. The following observations are derived from mistakes commonly made by less successful users, as well as the characteristics displayed by those who consistently make efficient and profitable use of the services available:

- 1) The initial task definition is assuredly the most important step in the use of the computer. The full magnitude of the problem must be clearly defined at the start to avoid the wasting of time, effort, and money.
- 2) Training in a common problem-oriented language (such as Fortran) is important to an engineer, not only as a tool to develop his own programs but also to aid in communicating with professional programmers and in the use of available applications programs.
- 3) The program library should be thoroughly investigated before embarking on the long, tedious, and expensive task of developing new software.
- 4) The applicable scientific computer center services, hardware, software, and procedures should be thoroughly understood.
- 5) Some engineers are reluctant to ask

for help; any unexplainable problem should be directed to the system programmer or center supervision.

- 6) Operating instructions should be written clearly; personal communications with operations personnel is generally not satisfactory in a high volume installation.
- 7) The engineer should apply the same standards of definition, planning, and understanding in his approach to a computational task as would be expected in a hardware design or development task.

#### FUTURE DEVELOPMENTS

There are two relatively recent developments which are having a major impact, on engineering users of scientific computer centers: availability of time sharing terminals and the capability of third-generation computer hardware/software. Time-sharing terminals have resulted in readily available computational capabilities which require limited familiarity at the beginning level. The learning process is rapid because of the interactive mode of operation; also, exposure to problem-oriented languages and applications systems via time-sharing terminals provides a broad familiarity on an economical basis. The result is that when the engineer's task outgrows the time-sharing terminal capability, he is prepared to smoothly transition to a scientific computer center.

Third generation hardware/software, as typified by the RCA Spectra systems, offers expanded storage, faster speeds, multi-programming, as well as a wide variety of languages and applications programs. A large number of specialized and easy to use application systems will evolve. The trend is toward more rapid turnaround times (a benefit primarily of the multi-programming capability) and accordingly more economical services. There will be a merging of the strengths of time-sharing terminals (availability, fast turnaround, interactive operation) with those of the scientific computer center (large storage, fast input/output, expanded languages, and application systems) in the future as software systems allow program preparation through time-sharing terminals, with "background" processing done on the same large scale machines. The engineer-user of computational services will witness a steady increase in the capabilities available to him; his utilization of these capabilities is largely dependent upon his maintaining pace in understanding and organizing their use.

---

The following page will introduce the reader to the authors Mr. J. B. Vail and Mr. J. R. Sandlin

**John R. Sandlin, Jr. - Mgr.**  
Data Processing and Analysis  
Scientific Information Processing Center  
RCA Missile and Surface Radar Division  
Moorestown, New Jersey  
received the B.S. in Electrical Engineering from the University of Florida in 1953. He spent three years as a USAF pilot and electronics officer, and joined RCA in 1965 at the USAF Eastern test Range Missile Test Project. He performed computer maintenance design, and system studies, joining M&SR in 1960 on DAMP (Down-range Anti Missile Program) where he supervised the data reduction effort. From 1963 to 1965, he was supervisor of RCA's Data Processing and Analysis activity for the TRADEX radar at Kwajalein, Marshall Islands. Mr. Sandlin returned to the Missile Test Project for two years, where he was manager of the ARIS Re-entry Ship Test Planning and Data Control activity. He is a member of IEEE, coholder of a patent for a Radar Video Data Reduction System and has authored numerous reports on missile re-entry test results.

**Jacque B. Vail, Ldr.**  
Computer Operations  
Scientific Information Processing Center  
RCA Missile and Surface Radar Division  
Moorestown, New Jersey  
received the B.S. in Civil Engineer from Pennsylvania State University in 1954. He was employed by the Ohio Department of Highway as a design engineer in the Photogrammic Design group, and in 1957 he became manager of the department's Electronic Computing Laboratory. Mr. Vail joined the M&SR division in 1961 as Leader, Computer Operations in the Scientific Information Processing Center. He has undertaken further studies in Business Administration and Data Processing at Ohio State University and Temple University. Mr. Vail is a registered Professional Engineer in the states of Ohio and New Jersey.

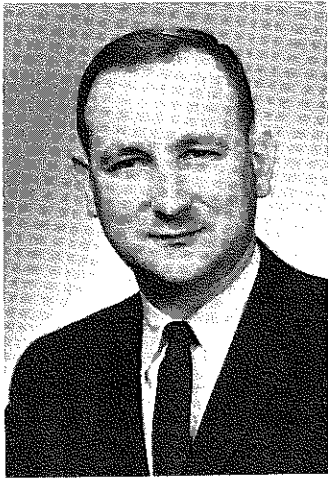

# A VECTOR ANALYSIS APPLICATION to GRAPHICS

by  
 Fryderyk E. Gorczyca  
 Assistant Professor  
 Mechanical Engineering Department  
 Southeastern Massachusetts Technological Institute

Isometric projection involves the projection of an object onto a plane, oriented in such a manner that perpendicular projectors, extending from the object, form an image on the plane such that the principal axes or edges of the object produce equal angles to the plane of projection. Standard texts<sup>1</sup> describe the operation of transforming a front view of an object in orthographic projection (Figure 1) to an isometric projection (Figure 3) as a  $45^\circ$  rotation about a vertical axis followed by a  $35^\circ 16'$  rotation about an horizontal axis. These two rotations are illustrated in Figure 2 and Figure 3. The front view, in Figure 3, is an isometric projection of the cube which results in projected  $30^\circ$  angular displacements of the axes on the plane of projection.

An analytical approach to this same problem can be stated that an isometric projection is defined and the angles through which the object must be rotated are to be determined. This type of approach lends itself more closely to a standard engineering type of analytical problem.

This paper deals with the solution to this problem both graphically, through projection of auxiliary views, and vectorially, through the application of vector analysis. The graphical solution involves the recognition of the fact that the diagonal of a cube, in an isometric projection view, must appear as a point. This results in equal angular displacements of the edges of the cube to the plane of projection. Figure one illustrates the procedure where the diagonal O-1 is defined in the top, front, and right side views.

The graphical solution is as follows: An auxiliary view is taken from the side view in such a manner that the plane of projection for the auxiliary view is parallel to the diagonal. This results in an auxiliary view showing the true length of the diagonal O-1. The next step is to draw a second auxiliary view in which the

line O-1 appears as a point. This is achieved by projecting the first auxiliary view onto a plane that is perpendicular to the diagonal O-1.

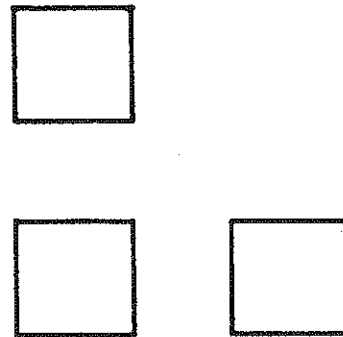

Figure 1  
 Three Views Of A Cube

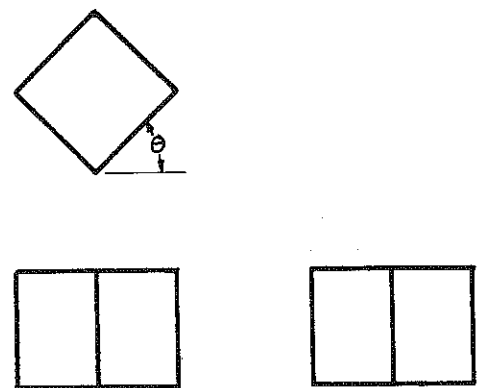

Figure 2  
 Cube Rotated  $45^\circ$  About A Vertical Axis

The resultant view (second auxiliary) shows the diagonal appearing as a point and the

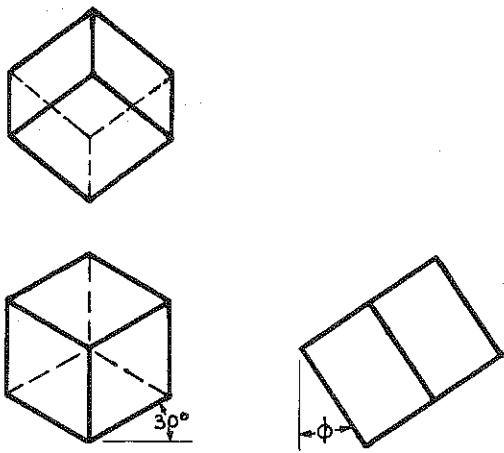

Figure 3  
Cube With Additional 35° 16' Rotation  
About A Horizontal Axis

principal edges O-2, O-3, and O-4 equally foreshortened. The resulting view is an isometric view of the cube. The angles  $\theta = 45^\circ$  and  $\phi = 35^\circ 16'$  as shown in Figure 4, correspond to the angle of rotation about the vertical axis and the angle of rotation about the horizontal axis.

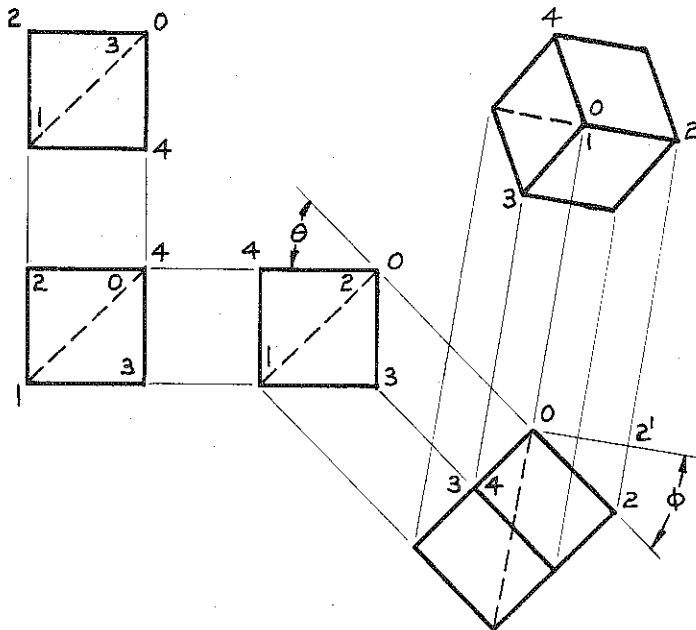

Figure 4  
Cube With Two Auxiliary Views

Another mode of thought yields the same results. If the cube diagonal is considered as the axis of a cone and the principal edges O-2, O-3, and O-4 are considered elements of the cone, the principal edges will make equal angular displacements with the plane of projection to which the diagonal O-1 is perpendicular.

The view formed on this plane of projection is an isometric projection since the principal edges are equally foreshortened. This approach is illustrated in Figure 5.

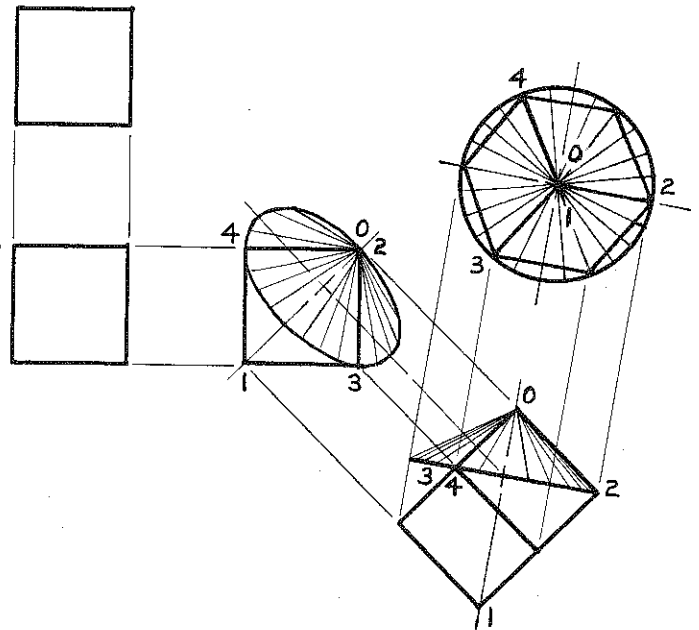

Figure 5  
Cone Imposed On Cube

Solving this same problem vectorially involves two rotations of the cube diagonal vector ( $\underline{R}$ ). With the first rotation, the vector  $\underline{R}$  is rotated about the  $\underline{k}$  axis into the  $\underline{i}$ - $\underline{k}$  plane yielding the vector  $\underline{R}_1$  as illustrated in Figures 6 (a) and 6 (b)

Determining the angle of rotation  $\theta$  by applying Rodrigues' Formula<sup>2</sup> we have

$$\underline{R}_1 - \underline{R} = \underline{W} \times (\underline{R}_1 + \underline{R}) \quad (\text{equation 1})$$

where

where  $\underline{W} = \underline{n} \tan \theta/2$  in which case  $\underline{n}$  is the direction of rotation and  $\theta$  is the angle of rotation.

$\underline{R} = \underline{i} + \underline{j} + \underline{k}$  (the diagonal of the cube before rotation)

$\underline{R}_1 = \sqrt{2}\underline{i} + \underline{k}$  (the diagonal of the cube after rotation)

Substituting into equation 1

$$\sqrt{2}\underline{i} + \underline{k} - \underline{i} - \underline{j} - \underline{k} = ((\tan \theta/2) \underline{k}) \times (\underline{R}_1 + \underline{R})$$

$$.415\underline{i} - \underline{j} = (\tan \theta/2) \underline{k} \times (2.415\underline{i} + \underline{j} + 2\underline{k})$$

$$.415\underline{i} - \underline{j} = \begin{vmatrix} \underline{i} & \underline{j} & \underline{k} \\ 0 & 0 & \tan \theta/2 \\ 2.415 & 1 & 2 \end{vmatrix}$$



$$.415i - j = i \begin{vmatrix} 0 & \tan \theta/2 \\ 1 & 2 \end{vmatrix} - j \begin{vmatrix} 0 & \tan \theta/2 \\ 2.415 & 2 \end{vmatrix} +$$

$$k \begin{vmatrix} 0 & 0 \\ 2.415 & 1 \end{vmatrix}$$

$$.415i - j = (\tan \theta/2)i + (2.415 \tan \theta/2)j$$

From this expression, by equating the i and j terms, we solve for the angle of rotation.

$$\begin{aligned} \tan \theta/2 &= -.415 & 2.415 \tan \theta/2 &= -1 \\ \theta/2 &= -22.5^\circ & \tan \theta/2 &= -1/2.415 \\ \theta &= -45^\circ & \theta/2 &= -22.5^\circ \\ & & \theta &= -45^\circ \end{aligned}$$

The second rotation involves the rotation of the vector  $\underline{R}_1$  about the j axis through the angle (angle of tilt) transforming  $\underline{R}_1$  into  $\underline{R}_2$ . This second rotation brings the diagonal of the cube into a position where it coincides with the i axis resulting in an isometric projection of the cube onto a plane of projection parallel to the j-k plane.

As illustrated in Figures 6a and 6b,  $\underline{R}_1$  can be written as

$$\begin{aligned} \underline{R}_1 &= \sqrt{2} i + k \\ \underline{R}_1 &= 1.415i + k \end{aligned}$$

and  $\underline{R}_2$  as

$$\begin{aligned} \underline{R}_2 &= \sqrt{3} i \\ \underline{R}_2 &= 1.732i \end{aligned}$$

Applying Rodrique's Formula to solve for we have

$$\begin{aligned} \underline{R}_2 - \underline{R}_1 &= \underline{W}_1 \times (\underline{R}_2 + \underline{R}_1) \\ \text{where } \underline{W}_1 &= \underline{n} \tan \phi/2 \\ \underline{W}_1 &= (\tan \phi/2)j \end{aligned}$$

Substituting yields

$$\begin{aligned} 1.732i - 1.415i - k &= ((\tan \phi/2)j) \times (\underline{R}_2 + \underline{R}_1) \\ .317i - k &= (\tan \phi/2)j \times (3.147i + k) \end{aligned}$$

$$.317i - k = \begin{vmatrix} i & j & k \\ 0 & \tan \phi/2 & 0 \\ 3.147i & 0 & 1 \end{vmatrix}$$

$$.317i - k = i \begin{vmatrix} \tan \phi/2 & 0 \\ 0 & 1 \end{vmatrix} - j \begin{vmatrix} 0 & 0 \\ 3.147 & 1 \end{vmatrix} +$$

$$k \begin{vmatrix} 0 & \tan \phi/2 \\ 3.147 & 0 \end{vmatrix}$$

from which

$$.317i - k = (\tan \phi/2)i - (3.147 \tan \phi/2)k$$

By equating i and k values the angle of tilt ( $\phi$ ) can be evaluated.

$$\begin{aligned} \tan \phi/2 &= .317 & \text{or} & 3.147 \tan \phi/2 = 1 \\ \phi/2 &= 17.6^\circ & \tan \phi/2 &= .317 \\ \phi &= 35.2^\circ & \phi/2 &= 17.6^\circ \\ & & \phi &= 35.2^\circ \end{aligned}$$

The analytical results, as listed above, coincide with the graphical determination of the angles of rotation about the k and j axes.

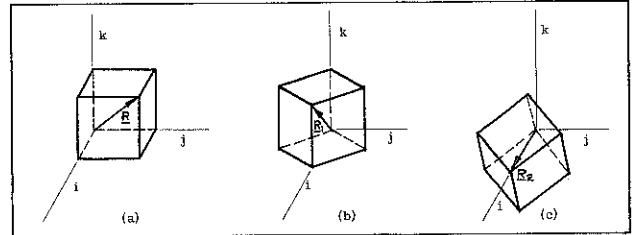
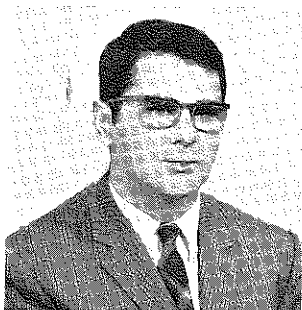

Figure 6  
Pictorial Representation Of Cube

In conclusion, it has been shown that isometric projection can be approached from a graphical as well as analytical manner. The graphical solution requires the projection of a secondary auxiliary view, whereas the analytical solution involves an application of Rodrique's Formula. Both methods yield the unknown angles of rotation.

#### References:

1. Giesecke, Mitchell, Spencer and Hill; TECHNICAL DRAWING; The MacMillan Company, New York, 1967.
2. Bisshopp, K. E., Lecture notes from N. S. F. Short Course on Vector Methods in Space Geometry for College teachers; Rensselaer Polytechnic Institute, Troy, New York, July 1967.



# AN EASY GRAPHICAL METHOD FOR FINDING THE RESULTANT OF ANY TWO FORCES

Professor Pedro Ramon Moliner  
 Escuela de Arquitectos Tecnicos  
 C. Universitaria  
 Madrid, Spain

**Abstract:** A new graphical method is described, allowing the construction of the resultant of any two forces, whether they be concurrent forces, forces that intersect at a point off the paper, or two parallel forces by drawing only two sets of parallel lines.

1. **Procedure:** Given the forces  $\underline{P}$  and  $\underline{Q}$  of Figure 1. It is desired to find their resultant  $\underline{R}$ , graphically. The following is the procedure;

- a) A line is drawn through the head of  $\underline{P}$  and the tail of  $\underline{Q}$ , and another line through the head of  $\underline{Q}$  and the tail of  $\underline{P}$  (dotted lines shown in Figure 1).
- b) Through the same four points the four possible parallels, to the dotted lines, are drawn.
- c) The head of  $\underline{R}$  is found at the intersection of the two new lines through the heads of  $\underline{P}$  and  $\underline{Q}$ . The tail of  $\underline{R}$  is found at the intersection of the other two new lines passing through the tails of  $\underline{P}$  and  $\underline{Q}$ .

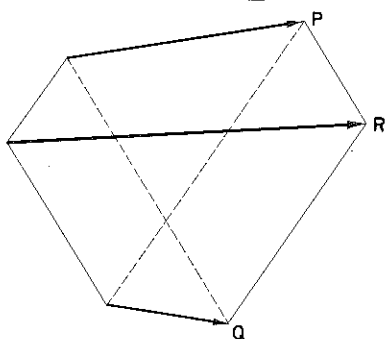

Fig. 1

It should be noted that;

- a) the entire construction is made by drawing two pairs of parallel lines, since in the actual construction the two dotted lines need not be drawn.
- b) the classical construction of the parallelogram, which is used when both forces are applied at their point of intersection, is only a particular case of the method introduced here.

2. **Demonstration:** The validity of the construction can be demonstrated by following, step by step, the equivalences established in Figure 2.

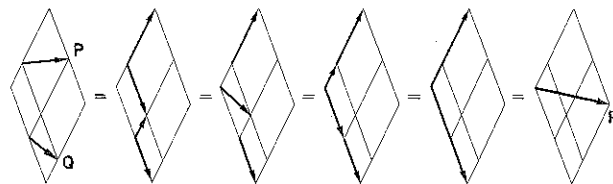

Fig. 2

3. **Examples:** This method is valid for any two forces as can be seen in the examples of Figure 3, which correspond to

- a) two parallel forces
- b) two anti-parallel forces
- c) two almost parallel forces
- d) two almost perpendicular forces

It should be noted that the resultant force  $\underline{R}$  is always obtained in a quite convenient position along its line of action.

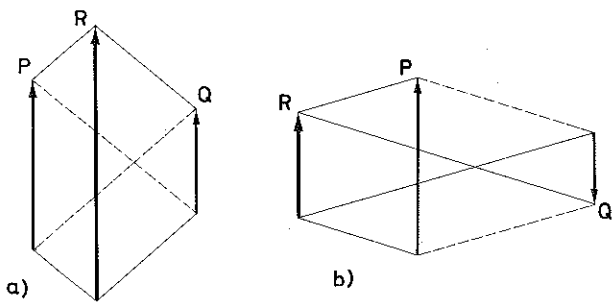
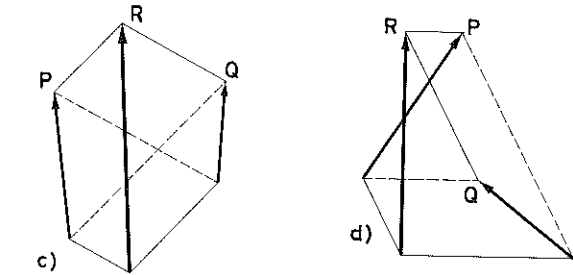

Fig. 3



4. Critical Position: There is a critical position of the two component forces to which this method cannot be immediately applied. That would be the particular case shown in Figure 4a, where the two dotted lines drawn through the head of one vector and the tail of the other are parallel to each other. Unless the two forces constitute a couple, this critical position can be easily overcome by sliding one of the forces to a new position along its line of action, as shown in Figure 4b.

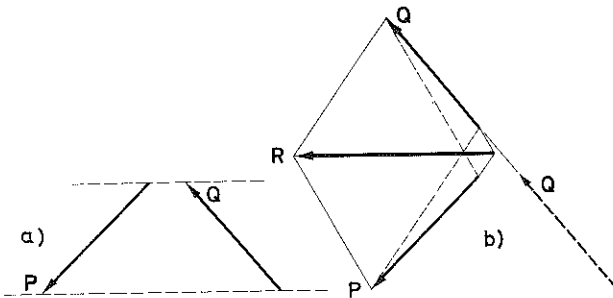

Fig. 4

5. Resultant Of More Than Two Forces: The case of more than two forces can always be solved by successive applications of the method to the forces taken in pairs, as can be seen in the examples shown in Figure 5. A detailed comparison of this method with any other known graphical method, such as the funicular polygon, demonstrates that the number of graphical operations required is always less.

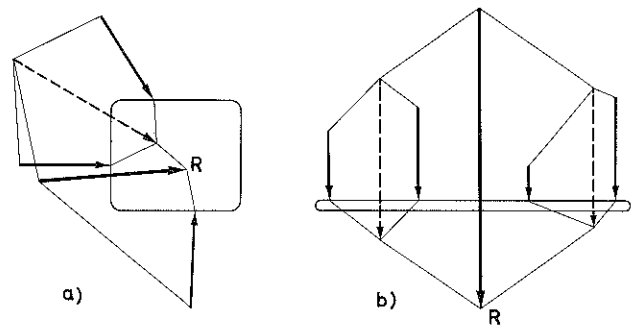

Fig. 5

6. The Converse Problem: Given the force  $\underline{R}$  in Figure 6. It is desired to find two components,  $\underline{P}$  and  $\underline{Q}$ , of  $\underline{R}$  such that  $\underline{P}$  act along the line  $e-e$  and  $\underline{Q}$  acts through point A.

Choosing point A as the tail of vector  $\underline{Q}$ , the construction can be done by drawing the auxiliary lines in the order shown in Figure 6. Point A could also have been chosen as the head of vector  $\underline{Q}$ .

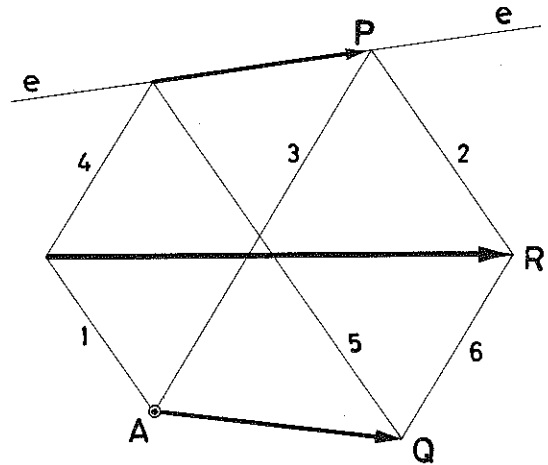
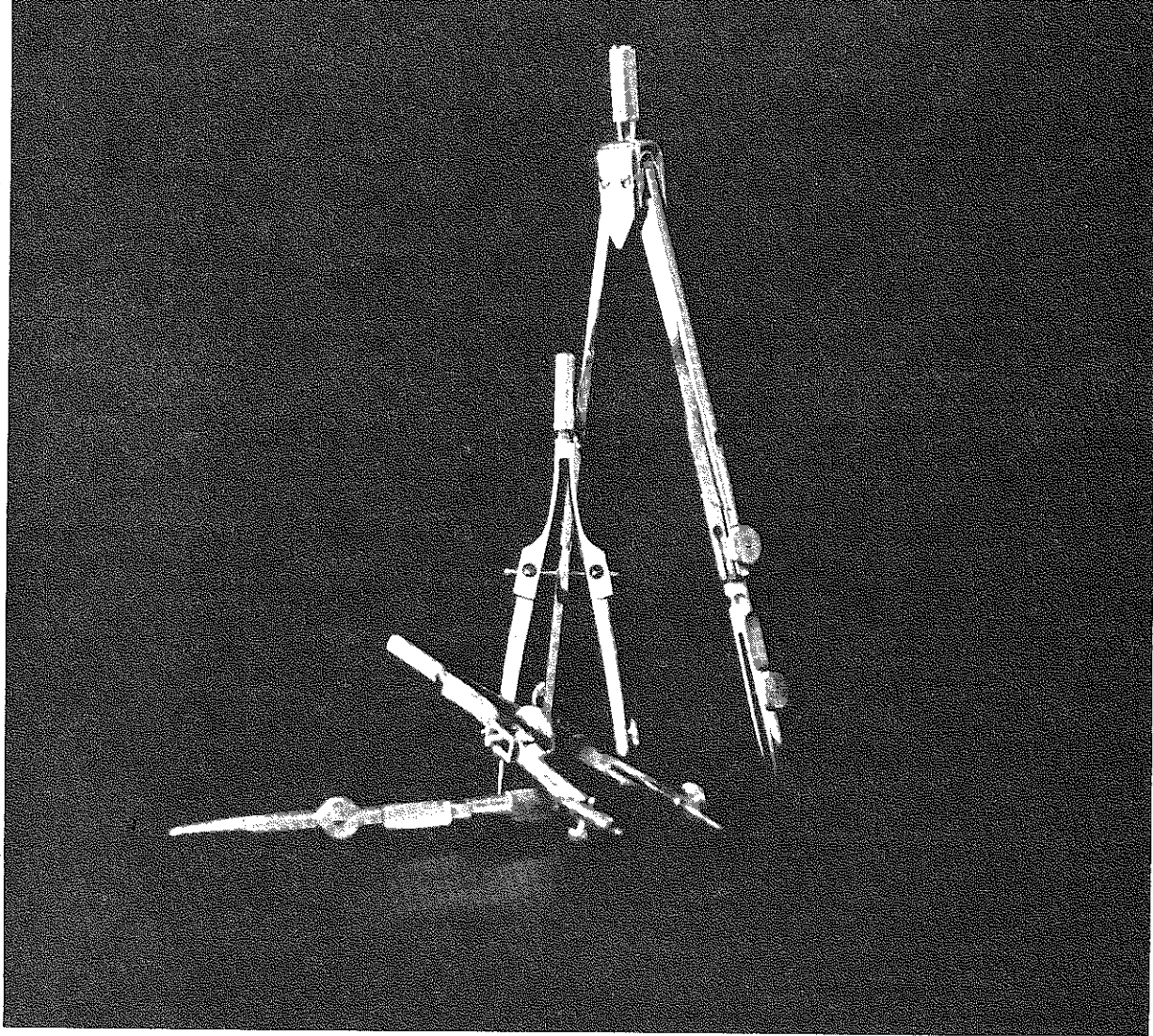

Fig. 6



## McGRAW-HILL ENGINEERING DRAWING, GRAPHICS, AND DESCRIPTIVE GEOMETRY TEXTS

---

### GEOMETRY OF ENGINEERING DRAWING, Fifth Edition

George J. Hood, deceased, Albert S. Palmerlee, Professor of Engineering Graphics, and Charles J. Baer, Professor of Engineering Graphics, both of the University of Kansas. Available Spring

This book, continuing to emphasize descriptive geometry, has been expanded to include other graphic materials required in most contemporary curricula.

### Special features

Eliminates the use of projection planes and fold lines by a direct approach to the multi-view presentation and solution of problems in descriptive geometry • Changes its coverage from that of a descriptive geometry text (without eliminating descriptive coverage) to that of an engineering graphics text through the addition of chapters on section views, dimensioning, use of instruments, drawing techniques, photodrawing, and vectors • Places the hundreds of problems closer to their respective topics • Includes such other new items as freehand sketching, oblique pictorial views and problems, the Golden Rectangle and Fibonacci numbers, and the USASI engineering lettering alphabet and the alphabet of lines.

## **PROBLEMS IN ENGINEERING GRAPHICS, SERIES VI**

**A. S. Levens**, College of Engineering, University of California, Berkeley, and **A. E. Edstrom**, City College of San Francisco. Available Spring

This book speeds the student's efforts to learn the fundamental principles of orthogonal projection and their application to the solution of a variety of technological three-dimensional problems. It enhances his ability to visualize and express his mental concepts graphically by the following means: freehand sketching—pictorial and orthographic—and understanding the basic principles of descriptive geometry and their applications. The authors extend the reader's knowledge of engineering graphics by making him solve problems in: (1) data presentation; (2) graphical mathematics—algebra, empirical equations, graphical integration and differentiation, functional scales, and elementary nomography; (3) conceptual design—open-ended design projects; (4) dimensioning—including true position; and (5) working drawings—both freehand and instrumental.

## **PROGRAMMED GRAPHICS**

**William F. Schneerer**, Case Western Reserve University, 608 pages, \$9.95

A programmed text designed for use as an aid in the teaching of engineering drawing. The text is developed on the premise that all students of technical drawing should be given a fundamental approach to the subject—the engineering-science oriented approach. Emphasizing communication by graphic means rather than the details and conventions of mechanical drafting, it covers: orthographic projection, pictorial drawing, drafting standards, descriptive geometry, and graphic mathematics.

## **ENGINEERING DRAWING WITH CREATIVE DESIGN, Second Edition**

**Hiram E. Grant**, Emeritus, Washington University, St. Louis. 334 pages, \$7.95

This revised textbook can now be used independently of a workbook, for problems have been added. An extensive chapter on creative design has also been added, and a wide selection of creative design problems is included in the problem section.

### **Other texts and problems books**

**CUSHMAN, et al.:** Problems in Graphics and Design, \$7.75

**GRANT:** Practical Descriptive Geometry Problems, Second Edition, \$4.95

**GRANT:** Engineering Drawing Problems, \$6.95

**HILL:** Problems in Graphical Analysis, \$6.50

**HOOD:** Descriptive Geometry Problems, \$4.95

**JOHNSON:** Engineering Graphics Problems, \$5.50

**McNEARY:** Problems in Engineering Drawing, \$6.50

**VIERCK-C.:** Engineering Drawing Problems, Series II, \$5.50

**VIERCK-HANG:** Fundamental Engineering Drawing Problems, Second Edition, \$4.95

**VIERCK-HANG:** Engineering Drawing Problems, Second Edition, \$5.95

**WARNER:** Descriptive Geometry Problems, Fifth Edition, \$4.95

**WEIDHAAS:** Engineering Graphics Problems, Alternate Edition, \$6.50

**WEIDHAAS:** Engineering Graphics Problems, \$5.95

**WEIDHAAS:** Descriptive Geometry Problems, \$4.95

**WELLMAN:** Problems for Descriptive Geometry, Second Edition, \$5.50

**ZOZZORA:** Engineering Drawing Problems, Second Edition, \$5.50



# A COMPARATIVE STUDY OF METRIC and UNIFIED - U.S. FASTENERS



by  
Robert Shaffer and Charles J. Baer  
Department of Mechanical Engineering  
The University of Kansas

## A. OBJECTIVES AND PROCEDURES

The stated objectives of this study was:  
"To formulate some information concerning differences between the proposed metric standard threaded fasteners and corresponding American Standard fasteners."

The proposed plan was to gather data on metric fasteners from such sources as library material, technical journals, publications of and concerning the International Standards Organization (ISO), and from industrial concerns. We were to obtain sample fasteners as produced by several European countries. After this data was gathered, it was to be analyzed to determine the outstanding differences between metric and unified thread fasteners.

## B. COMPARISON OF THREAD STANDARDS

Unified fasteners have become highly standardized because of the length of time they have been used and the high demands being placed upon them by U. S. industry. However, metric fasteners have only recently been standardized. In fact, even now they are not completely standardized. The International Standards Organization (ISO) is attempting to establish complete, acceptable standards. Much of the material contained herein was obtained from their proposals. Generally, the efforts in ISO activities terminate in recommendations. They are not binding on the member bodies but are intended as guides. Statements by various delegations at the 1961 meeting of ISO/TC-1 indicate that the metric countries

are ready to accept most of the ISO metric thread package.

The triangular screw thread basic profile, which is the same for both, the metric and unified systems, is shown in Figure 1.

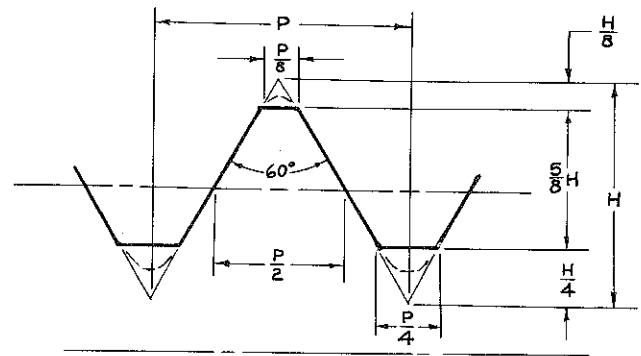
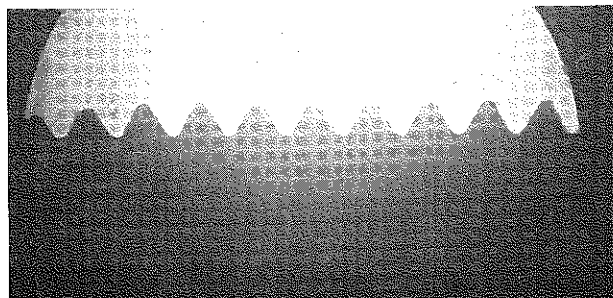

Figure 1. The basic profile of the metric and unified screw thread.

In this figure are shown two alternate shapes (flat and rounded) for the crests and roots. The reason for the alternate shapes lies in the construction of the dies with which (most) threads are rolled. In England, and in the metric countries, the forming die is rounded at the roots. In the U. S. A. the die is usually made flat at the root. However, the forming die usually becomes rounded with wear. Thus, the production-line bolt or screw in this country usually exhibits the same thread profile, when viewed through an optical comparator, that the equivalent British or metric fastener shows.

Figure 2 shows an enlarged view of each of the three threads of approximately the same size. These views of Swiss, German and American cap screw threads show the same thread profile for each fastener.



7/16 inch U. S.

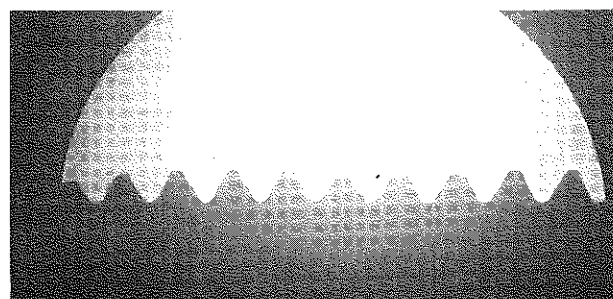

12mm German

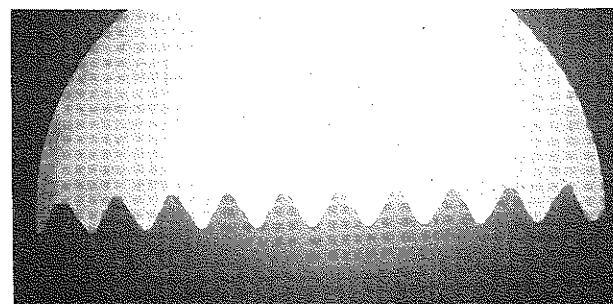

12mm Swiss

Figure 2. Cap screw thread profiles:

#### C. UNIFIED AND METRIC THREAD PITCHES

The pitch diameter and pitch are, of course, different for metric fasteners and unified fasteners. Unified fasteners are designated by giving the pitch diameter (in inches) and the number of threads per inch. Metric fasteners are designated by giving the pitch diameter (in millimeters) and the pitch (in millimeters). Appendices A and B list the standard sizes of unified and metric fasteners. In Table I, we have attempted to indicate a "corresponding" metric fastener for each unified fastener of coarse and fine pitch in sizes up to one inch. We have added columns to the metric specifications giv-

ing the equivalent diameter in inches and the number of threads per inch corresponding to the pitch in millimeters so that the reader may readily compare fasteners. It should be pointed out that these corresponding fasteners are, in general, not interchangeable.

#### D. HEAD AND NUT SIZES

The sizes of metric and unified series bolt heads and nuts are specified in ISO Recommendation R272, Appendix C. Here, an investigation noted that there was more deviation between samples. In the case of the metric bolts, the distance across flats varied almost as much as the limits (normal and small) listed in the table, but were within the limits. One of the U. S. 3/4 inch bolts, however, was .025 inch less than the indicated distance, and none of the U. S. nuts or hex heads exactly equalled the distance given in the standard. Perhaps the metric system of assigning limits is more realistic and practical.

But the main objective in studying head and nut sizes is to determine whether U. S. wrenches will fit metric nuts and bolts, and vice-versa. This was done for the hexagon-head cap screws of Swiss, German and U. S. manufacture. The dimensions were also checked against ISO R 272 as indicated in the preceding paragraph. Between the ranges of 8mm and 24 mm diameters we found a surprisingly large number of cases where wrenches of one system would fit the fasteners of the other system. Table II shows two classifications where interchangeability exists. It is felt that those listed in the "good fit" category may be used in nearly all situations, and those in the "loose fit" category may be subject to excessive slippage if extreme torque is applied.

#### E. THREAD AND BOLT LENGTHS

Proposals dictating standard nominal length and thread lengths for both metric and unified fasteners are under consideration by ISO. These proposals, which have not been approved as recommendations yet, are shown in Appendix D. To our knowledge, nominal lengths have not been previously standardized, even for unified fasteners. The American Standards Association standard B 18.2, concerning hex-head cap screws, states "Minimum thread lengths shall be twice the diameter plus 1/4 inch for lengths up to and including 6 inches; twice the diameter plus 1/2 inch for lengths over 6 inches." It will be noted that this minimum-

thread length does not conflict with the ISO proposal, even though it is not specified in the same manner. The ISO proposal listing standard nominal lengths corresponds fairly well with those produced by several American manufacturers.

#### F. STRENGTH OF FASTENERS

The strength of a fastener depends primarily upon the material used. Also involved are the pitch, tolerance, sharpness of roots and smoothness and regularity of form.

The tensile strength of fasteners of the same material\* may be compared by using the tensile strength area(s). This area, which actually bears the load, may be computed from the following formulae:

$$A_s = .7854 \left( D - \frac{.9743}{N} \right)^2$$

D = nominal diameter

N = no. of threads per length

(or)

$$A_s = .7854 (D - .9743P)^2$$

D = nominal diameter

P = pitch

These formulae indicate that a fastener with fine threads will be stronger than one with coarse threads: For sizes up to approximately one inch, metric threads are of slightly smaller pitch than corresponding unified threads. Therefore, the metric tensile area is the greater of the two; the maximum being about 17 percent. However, this is not completely an advantage because as the tensile strength increases the shear strength decreases. For soft, ductile materials such as aluminum, the fastener may fail by shearing before the tensile strength of the fastener is exceeded. For such materials the coarser thread would be more suitable.

In arriving at certain tolerances, the ISO committee set up a strength grading system. This was a compromise of existing systems. U. S. engineers have suggested that the metric strength classification system is not as good as ours. It does embody, however, many features of the unified system. We do not have good data on these systems.

#### G. COMMENTS ABOUT ACTUAL SPECIMENS

Our specimens were obtained in the fol-

lowing ways:

1. Unified fasteners (U. S.) --- Purchase from hardware stores and borrowing from stockrooms.
2. Metric fasteners (U. S.) --- From a foreign car repair shop: these were made in the U. S. A.
3. Swiss and German ----- By correspondence with manufacturers who were suggested by foreign students and engineers.
4. French ----- By purchase in a Paris hardware store, after correspondence with a manufacturer failed to get a reply or shipment.

The fasteners ranged in size from 1/4" to 3/4" (unified) and 4mm to 20mm (metric). All threads were coarse threads. (In purchasing or ordering fasteners, we did not specify the type of threads.) The fasteners were examined by the naked eye, by feel, by weight and by optical comparator (see Appendix E). Figure 2 shows how three typical specimens appeared when viewed through the comparator and photographed with a Polaroid Land camera. These were three of about 60 samples that were studied.

#### H. CONCLUSIONS

1. There are no striking differences in the external thread form as produced in several countries (U. S. included), whether the thread is metric or unified.
2. The crests of the threads are rounded, with the radius of the unified crest slightly larger than the metric.
3. The roots are rounded on all fastener threads.
4. Metric fasteners are manufactured in the U. S. with heads that will fit U. S. wrenches.
5. None of the metric fasteners are completely interchangeable with unified fasteners, although some metric nuts will loosely fit on U. S. fasteners as follows:

---

\* Fasteners are available in a variety of ferrous and non-ferrous metals.



Swiss Nut	U. S. Bolt
20mm	3/4 - 10
12mm	7/16 - 14
10mm	3/8 - 16

The corresponding U. S. nuts will not fit on the Swiss or German bolts.

6. Some U. S. standard end and socket wrenches will fit metric hex head bolts and nuts, and vice versa. However, there are many cases where there are no wrenches of one system that will fit bolts and nuts of the other system.

7. The European countries are adopting the ISO metric fastener standards as is evidenced by the interchangeability of the French, German and Swiss fasteners that were bought on the "open market".

8. There is an ISO standard for the unified thread series as well as for the metric thread series. This is a virtual adoption of the then existing unified standard, which was formulated by the U. S., England, and other "inch-pound" countries.

9. Sooner or later (and preferably

sooner) the U. S. A. will have to decide whether to adopt the metric system or to stay with the inch-pound system. Conversion to the metric thread, as one example, would be expensive and present many difficulties. However, to delay the conversion by ten, twenty or fifty years will no doubt add to the expense and difficulty.

#### I. RECOMMENDATIONS FOR FUTURE PROJECTS

Recognizing the fact that England and Japan are converting to the metric system the following studies would be in order:

a) A study of the conversion to the metric system by all segments of U. S. commerce and industry. A separate study might have to be made for each segment.

b) A cost study for the conversion of this country from the unified threads to the metric threads. Such a study will probably have to envision several plans of how and when such a conversion would take place. The costs, alone, would be enormous.

Table I  
APPROXIMATE EQUIVALENT SCREW THREAD SIZES  
In The  
UNIFIED AND METRIC SYSTEMS

UNIFIED			METRIC					
DIAMETER		THREADS PER INCH	DIAMETER		PITCH (millimeters)		EQUIVALENT THREADS PER INCH	
INCHES		COARSE FINE	In.	mm.	COARSE	FINE	COARSE	FINE
No. 0	- .060	80	.063	1.6	.35		72.6	
No. 2	- .086	56 64	.0787	2.0	.4	.25	63.5	100.2
No. 4	- .112	40 48	.0984	2.5	.45	.35	56.5	72.6
No. 5	- .125	40 44	.1181	3.0	.5	.35	50.8	72.6
No. 6	- .138	32 40						
No. 8	- .164	32 36	.1575	4.0	.7	.5	36.3	50.8
No. 10	- .190	24 32	.1969	5.0	.8	.5	31.8	50.8
1/4	- .250	20 28	.2362	6.0	1.0	.75	25.4	33.9
5/16	- .312	18 24	.3150	8.0	1.25	1.0	20.3	25.4
3/8	- .375	16 24	.3937	10.0	1.5	1.25	16.9	20.3
7/16	- .437	14 20						
1/2	- .500	13 20	.4724	12.0	1.75	1.25	14.5	20.3
9/16	- .562	12 18						
5/8	- .625	11 18	.6299	16.0	2.0	1.5	12.7	16.9
3/4	- .750	10 16	.7874	20.0	2.5	1.5	10.6	16.9
7/8	- .875	9 14						
1	- 1.000	8 12	.9449	24.0	3.0	2.0	8.47	12.7

Table II

INTERCHANGEABLE END WRENCHES  
(Column (1) will fit (2); (3) will fit (4))

GOOD FIT			
WRENCH SIZE		WRENCH SIZE	
(1) Metric	(2) Unified	(3) Unified	(4) Metric
11 mm.	7/16 in.	7/16 in.	11 mm.
13 mm.	1/2 in.	1/2 in.	12 mm.
14 mm.	9/16 in.	9/16 in.	14 mm.
19 mm.	3/4 in.	11/16 in.	17 mm.
22 mm.	7/8 in.	3/4 in.	19 mm.
24 mm.	15/16 in.	7/8 in.	22 mm.

LOOSE FIT			
10 mm.	3/8 in.	3/8 in.	9 mm.
17 mm.	5/8 in.		

## Appendix A

## UNIFIED SCREW THREAD - STANDARD SERIES

SIZE DESIGNATION		BASIC MAJOR DIAMETER	THREADS PER INCH										
			Series with graded pitches			Series with constant pitches							
Primary	Secondary		Course UNC	Fine UNF	Extra fine UNEF	4UN	6UN	8UN	12UN	16UN	20UN	28UN	32UN
0	1	0.0600 0.0730	.. 64	80 72	.. ..	..	..	..	..	..	..	..	..
2	3	0.0860 0.0990	56 48	64 56	.. ..	..	..	..	..	..	..	..	..
4		0.1120	40	48	..	..	..	..	..	..	..	..	..
5		0.1250	40	44	..	..	..	..	..	..	..	..	..
6		0.1380	32	40	..	..	..	..	..	..	..	..	UNC
8		0.1640	32	36	..	..	..	..	..	..	..	..	UNC
10	12	0.1900 0.2160	24 24	32 28	.. 32	..	..	..	..	..	..	..	UNF UNEF
1/4		0.2500	20	28	32	..	..	..	..	..	UNC	UNF	UNEF
5/16		0.3125	18	24	32	..	..	..	..	..	20	28	UNEF
3/8		0.3750	16	24	32	..	..	..	..	UNC	20	28	UNEF
7/16		0.4375	14	20	28	..	..	..	..	16	UNF	UNEF	32
1/2		0.5000	13	20	28	..	..	..	..	16	UNF	UNEF	32
9/16		0.5625	12	18	24	..	..	..	UNC	16	20	28	32
5/8	11/16	0.6250 0.6875	11 ..	18 ..	24 24	..	..	..	12	16	20	28	32
3/4		0.7500	10	16	20	..	..	..	12	16	UNF	UNEF	28
	13/16	0.8125	..	..	20	..	..	..	12	16	UNEF	28	32
7/8		0.8750	9	14	20	..	..	..	12	16	UNEF	28	32
	15/16	0.9375	..	..	20	..	..	..	12	16	UNEF	28	32
1		1.0000	8	12	20	..	..	UNC	UNF	16	UNEF	28	32
	1 1/16	1.0625	..	..	18	..	..	8	12	16	20	28	..
1 1/8		1.1250	7	12	18	..	..	8	UNF	16	20	28	..
	1 3/16	1.1875	..	..	18	..	..	8	12	16	20	28	..
1 1/4		1.2500	7	12	18	..	..	8	UNF	16	20	28	..
	1 5/16	1.3125	..	..	18	..	..	8	12	16	20	28	..
1 3/8		1.3750	6	12	18	..	UNC	8	UNF	16	20	28	..
	1 7/16	1.4375	..	..	18	..	..	6	8	12	16	20	28
1 1/2		1.5000	6	12	18	..	UNC	8	UNF	16	20	28	..
	1 9/16	1.5625	..	..	18	..	..	6	8	12	16	20	..
1 5/8		1.6250	..	..	18	..	..	6	8	12	16	20	..
	1 11/16	1.6875	..	..	18	..	..	6	8	12	16	20	..
1 3/4		1.7500	5	..	..	..	..	6	8	12	16	20	..
	1 13/16	1.8125	..	..	..	..	..	6	8	12	16	20	..

Appendix B  
TABLE OF SCREW THREADS

Nominal Diameters				Pitches																
Col. 1	Col. 2	Col. 3	coarse	fine																
				3	2	1.5	1.25	1	0.75	0.5	0.35	0.25	0.2							
0.25			0.075																	
0.3	0.35		0.08 0.09																	
0.4	0.45		0.1 0.1																	
0.5			0.125																	
0.6	0.55		0.125																	
	0.7		0.15 0.175																	
0.8			0.2																	
	0.9		0.225																	
1			0.25																	0.2
	1.1		0.25																	0.2
1.2			0.25																	0.2
	1.4		0.3																	0.2
1.6			0.35																	0.2
	1.8		0.35 0.4																	0.25 0.25
2.5	2.2		0.45																	
3			0.45 0.5																	0.35 0.35
4	3.5		0.6																	
	4.5		0.7 0.75																	0.5 0.5
5			0.8																	0.5 0.5
6		5.5	1																	0.75
		7	1																	0.75
8		9	1.25							1										0.75
			1.25							1										0.75
10			1.5						1.25	1										0.75
		11	1.5							1										0.75
12			1.75						1.5	1.25	1									
	14		2						1.5	1.25*	1									
		15	2						1.5		1									
16			2						1.5		1									
		17	2.5						1.5		1									
	18		2.5					2	1.5		1									
20			2.5					2	1.5		1									
	22		2.5					2	1.5		1									
24			3					2	1.5		1									
		25						2	1.5		1									
		26							1.5											
	27		3					2	1.5		1									
		28						2	1.5		1									
30			3.5	(3)				2	1.5		1									
		32		(3)				2	1.5											
	33		3.5	(3)				2	1.5											
		35**							1.5											
36			4					3	1.5											
		38						2	1.5											
	39		4					3	1.5											

(continued)

Avoid as far as possible pitches in brackets

- \* Pitch 1.25 of diameter 14: to be used only for spark plugs for engines
- \*\* Diameter 35: to be used only for locking nuts for bearings

TABLE OF SCREW THREADS  
(continued)

Nominal Diameters			Pitch					
Col. 1	Col. 2	Col. 3	coarse	fine				
				6	4	3	2	1.5
42		40	4.5		4	3	2	1.5
	45		4.5		4	3	2	1.5
48		50	5		4	3	2	1.5
	52		5		4	3	2	1.5
56		55	5.5		4	3	2	1.5
		58			4	3	2	1.5
64	60	62	5.5		4	3	2	1.5
			6		4	3	2	1.5
	68	65	6		4	3	2	1.5
		70		6	4	3	2	1.5
72		75		6	4	3	2	1.5
	76			6	4	3	2	1.5
80		78		6	4	3	2	1.5
		82					2	
90	85			6	4	3	2	
	95			6	4	3	2	
100	105			6	4	3	2	
				6	4	3	2	
110				6	4	3	2	
				6	4	3	2	
125	115			6	4	3	2	
	120			6	4	3	2	
140	130	135		6	4	3	2	
				6	4	3	2	
	150	145		6	4	3	2	
		155		6	4	3	2	
160		165		6	4	3		
	170			6	4	3		
180		175		6	4	3		
		185		6	4	3		
200	190	195		6	4	3		
				6	4	3		
	210	205		6	4	3		
		215		6	4	3		
220		225		6	4	3		
		230		6	4	3		
	240	235		6	4	3		
		245		6	4	3		
250		255		6	4	3		
	260			6	4			

Appendix C

HEXAGON BOLTS AND NUTS  
Widths Across Flats, Heights of Heads,  
Thickness of Nuts

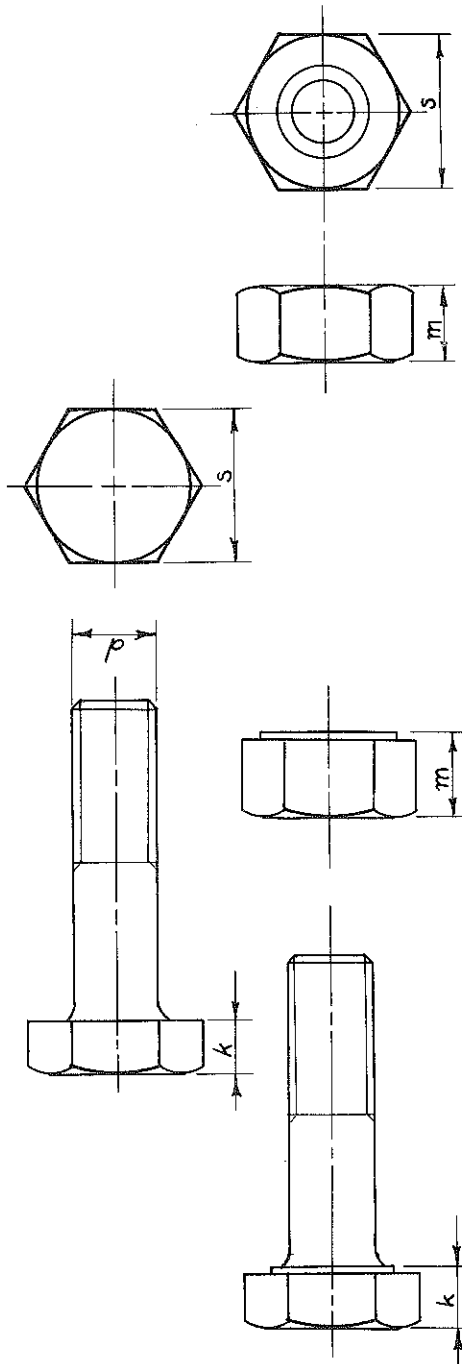

1. BASIC DIMENSIONS: METRIC SYSTEM

2. BASIC DIMENSIONS: INCH SERIES

Dimensions in millimeters

Thread diameter	Width across flats**		Height of head	Thickness of nut
	normal	small		
1.6*	3.2	--	1.1	1.3
2 *	4	--	1.4	1.6
2.5*	5	--	1.7	2
3 *	5.5	--	2	2.4
4 *	7	--	2.8	3.2
5 *	8	--	3.5	4
6	10	--	4	5
7	11	--	5	5.5
8	13	12	5.5	6.5
10	17	14	7	8
12	19	17	8	10
14	22	19	9	11
16	24	22	10	13
18	27	24	12	15
20	30	27	13	16
22	32	30	14	18
24	36	32	15	19
27	41	36	17	22
30	46	41	19	24
33	50	46	21	26
36	55	50	23	29
39	60	55	25	31

Dimensions in inches

Sizes	Thread diameter	Width across flats		Height of head	Thickness of nut
		bolt	nut		
No. 0	0.060	---	0.1562	---	0.050
No. 1	0.073	---	0.1862	---	0.050
No. 2	0.086	0.1250	0.1875	0.050	0.066
No. 3	0.099	0.1375	0.1875	0.055	0.066
No. 4	0.112	0.1375	0.2500	0.060	0.098
No. 5	0.125	0.1875	0.3125	0.070	0.114
No. 6	0.138	0.2500	0.3125	0.093	0.114
No. 8	0.164	0.2500	0.3438	0.110	0.130
No. 10	0.190	0.3125	0.3750	0.120	0.130
No. 12	0.216	0.3125	0.4375	0.155	0.161
1/4	0.250	0.4375	0.4375	0.163	0.226
5/16	0.3125	0.5000	0.5000	0.211	0.273
3/8	0.375	0.5625	0.5625	0.248	0.337
7/16	0.4375	0.6250	0.6875	0.281	0.385
1/2	0.500	0.7500	0.7500	0.323	0.448
9/16	0.5625	0.8125	0.8750	0.371	0.496
5/8	0.625	0.9375	0.9375	0.403	0.559
3/4	0.750	1.1250	1.1250	0.483	0.665
7/8	0.875	1.3125	1.3125	0.563	0.776
1	1.000	1.5000	1.5000	0.627	0.887
1 1/8	1.125	1.6875	1.6875	0.718	0.999
1 1/4	1.250	1.8750	1.8750	0.813	1.094
1 3/8	1.375	2.0625	2.0625	0.875	1.206
1 1/2	1.500	2.2500	2.2500	0.974	1.317
1 3/4	1.750	2.6250	2.6250	1.134	1.540
2	2.000	3.0000	3.0000	1.263	1.763

\* The metric thread diameters 1.6 to 5 mm. conform to ISO Recommendation R 68, SCREW THREADS.

\*\* Where the larger metric hexagons are required, the next larger width across flats for any given diameter, as shown in the normal metric series, should be chosen.

DRAFT ISO PROPOSAL  
BOLTS SCREWS AND STUDS

Nominal Lengths  
Thread Lengths

## 1. Nominal Lengths (l)

## Basic dimensions

Metric		Inch		Metric		Inch	
2		1/16		65		2 1/2	
-		(5/64)		70		2 3/4	
2, 5		3/32		75		3	
3		1/8		80		3 1/4	
4		5/32		85		-----	
55		3/16		90		3 1/2	
6		1/4		(95)		(3 3/4)	
(7)		---		100		4	
8		5/16		(105)		(4 1/4)	
(9)		---		110		4 1/2	
10		3/8		(115)		-----	
(11)		7/16		120		(4 3/4)	
12		1/2		(125)		-----	
14		9/16		130		5	
16		5/8		---		(5 1/4)	
(18)		---		140		5 1/2	
20		3/4		---		(5 3/4)	
(22)		(7/8)		150		6	
25		1		160		-----	
(28)		1 1/8		170		6 1/2	
30		1 1/4		180		7	
(32)		---		190		7 1/2	
35		1 3/8		200		8	
(38)		---		225		9	
40		1 1/2		250		10	
45		1 3/4		(steps		(steps	
50		2		of		of	
55		2 1/4		25 mm)		1 in.)	
60							

Lengths in brackets should be avoided if possible

## 2. Thread Lengths (b)

## Formulae

Nominal Length (l)				Thread Length (b)	
Metric		Inch		Metric	Inch
over	to	over	to		
	90		3 1/2	$2d + 6$	$2d + 1/4$
90	200	3 1/2	8	$2d + 12$	$2d + 1/2$
200		8		$2d + 25$	$2d + 1$

Appendix E

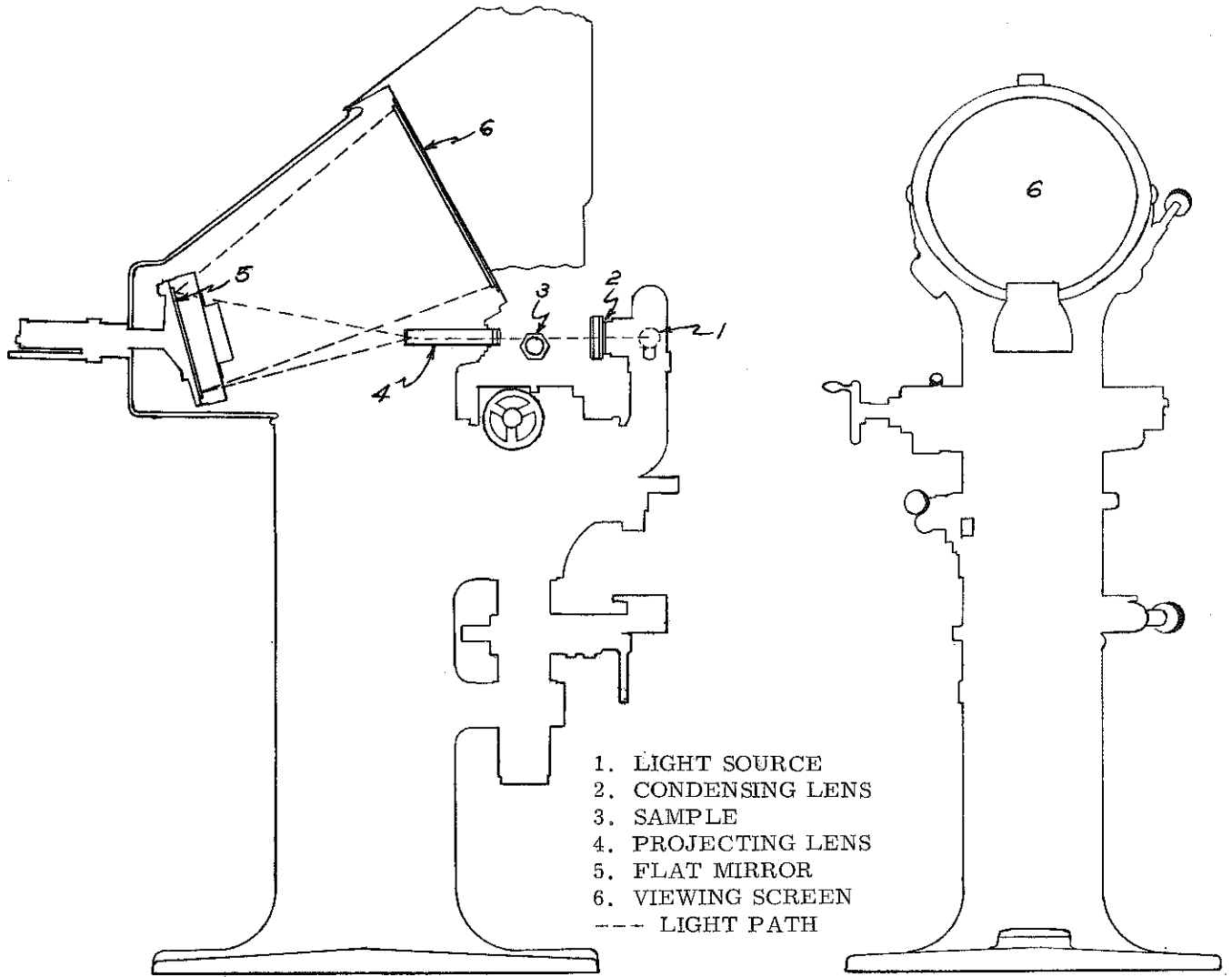

- 1. LIGHT SOURCE
- 2. CONDENSING LENS
- 3. SAMPLE
- 4. PROJECTING LENS
- 5. FLAT MIRROR
- 6. VIEWING SCREEN
- LIGHT PATH

*OPTICAL COMPARATOR*



# YES!



EARLE

I WANT A  
SUBSCRIPTION  
TO THE

Journal of engineering graphics  
journal of engineering graphics  
journal of engineering graphics  
journal of engineering graphics  
journal of engineering graphics

To: Professor WILFRED P. RULE  
Department of Engineering Graphics  
400DG  
Northeastern University  
Boston, Massachusetts 02115

Enter my subscription to the JOURNAL for:  
\_\_\_ 1year @ \$2: \_\_\_ 2years @ \$4: \_\_\_ 3years @ \$6

NAME \_\_\_\_\_

ADDRESS \_\_\_\_\_

CITY and STATE \_\_\_\_\_

ZIP CODE \_\_\_\_\_



(Photo courtesy of Ralph Northrup)

INDEX TO ADVERTISERS

	<u>Page</u>
Addison-Wesley -----	2
Braddock -----	4
Algee -----	17
MacMillan -----	18
	19
Alteneder -----	20
Wm. C. Brown -----	In. Fr. Cover
	26
	27
Gramercy -----	33
	34
	35
	36
McGraw-Hill -----	54
	55
W. E. Street -----	In. Back Cover
Staedtler-Mars -----	Out. Back Cover

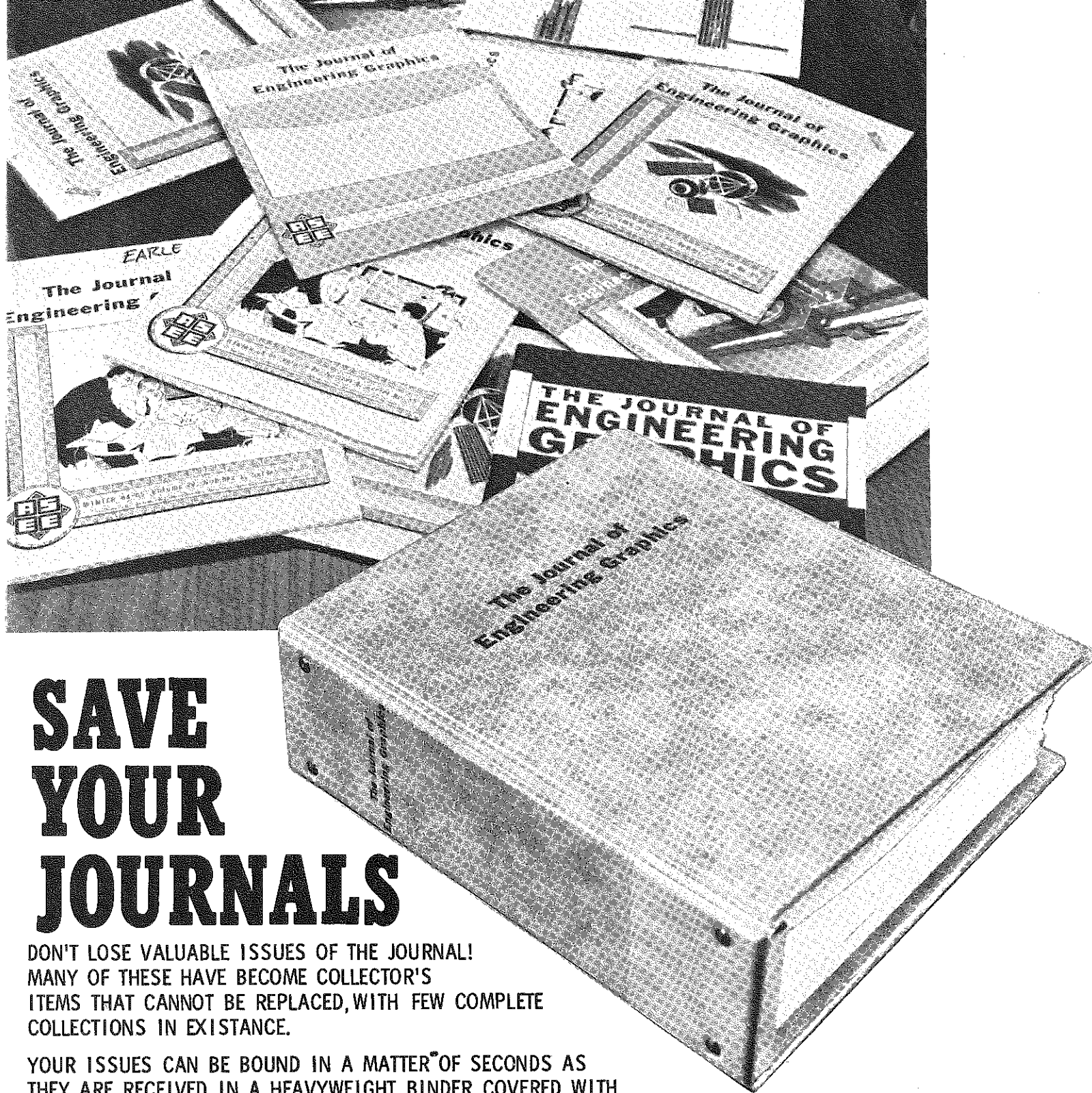

# SAVE YOUR JOURNALS

DON'T LOSE VALUABLE ISSUES OF THE JOURNAL!  
MANY OF THESE HAVE BECOME COLLECTOR'S  
ITEMS THAT CANNOT BE REPLACED, WITH FEW COMPLETE  
COLLECTIONS IN EXISTANCE.

YOUR ISSUES CAN BE BOUND IN A MATTER OF SECONDS AS  
THEY ARE RECEIVED IN A HEAVYWEIGHT BINDER COVERED WITH  
A LEATHER-FINISHED VINYL FOR LONG-  
LASTING SERVICE. EACH BINDER HOLDS  
HOLDS FOUR YEARS OF ISSUES  
(12 ISSUES) FOR PERMANENT REFERENCE.  
ISSUES CAN BE EASILY REMOVED  
FROM EACH BINDER WHEN NEEDED.

ORDER YOUR BINDERS NOW AT A COST  
OF \$3.25 WHICH INCLUDES POSTAGE  
AND HANDLING.

TO: WILFRED P. RULE, 400DG, Northeastern University,  
Boston, Massachusetts 02115

Send me \_\_\_ binders @ \$3.25 each. Enclosed is \$ \_\_\_\_\_

NAME \_\_\_\_\_

ADDRESS \_\_\_\_\_

CITY & STATE \_\_\_\_\_

ZIP CODE \_\_\_\_\_

# TESTED TEACHING AIDS FOR ENGINEERING DRAWING

BY CARL L. SVENSEN AND WILLIAM E. STREET

FOR USE WITH ANY TEXT OR NO TEXT

## DRAFTING PROBLEM LAYOUTS

SERIES C , REVISED

Work sheets covering Vertical and Inclined Lettering, Sketching, Use of Instruments, Engineering Geometry, Scales, Orthographic Projection, Revolution, Auxiliary Projection, Sections and Conventions, Dimensioning, Screw Threads and Bolts, Isometric, Oblique, Perspective, Developments, Intersections, Working Drawings, and Creative Design.

95 Work Sheets, 8 1/2" X 11" \_\_\_\_\_ \$5.00

## DRAFTING PROBLEM LAYOUTS

SERIES D, REVISED

Work sheets covering Vertical and Inclined Lettering, Sketching, Use of Instruments, Engineering Geometry, Scales, Orthographic Projection, Revolution, Auxiliary Projection, Sections and Conventions, Isometric, Oblique, Dimensioning, Developments, Intersections, Screw Threads, Studies of Points, Lines, and Planes, and Creative Design.

100 Work Sheets, 8 1/2" X 11" \_\_\_\_\_ \$5.00

## VERTICAL LETTERING EXERCISES

Vertical Lettering with Instructions.

6 Work Sheets, 8 1/2" X 11" \_\_\_\_\_ \$0.75

## INCLINED LETTERING EXERCISES

Inclined Lettering with Instructions.

6 Work Sheets, 8 1/2" X 11" \_\_\_\_\_ \$0.75

WRITE FOR EXAMINATION COPY OR ORDER FROM

W. E. STREET  
ENGINEERING GRAPHICS DEPARTMENT  
LOUISIANA STATE UNIVERSITY  
BATON ROUGE, LOUISIANA 70803



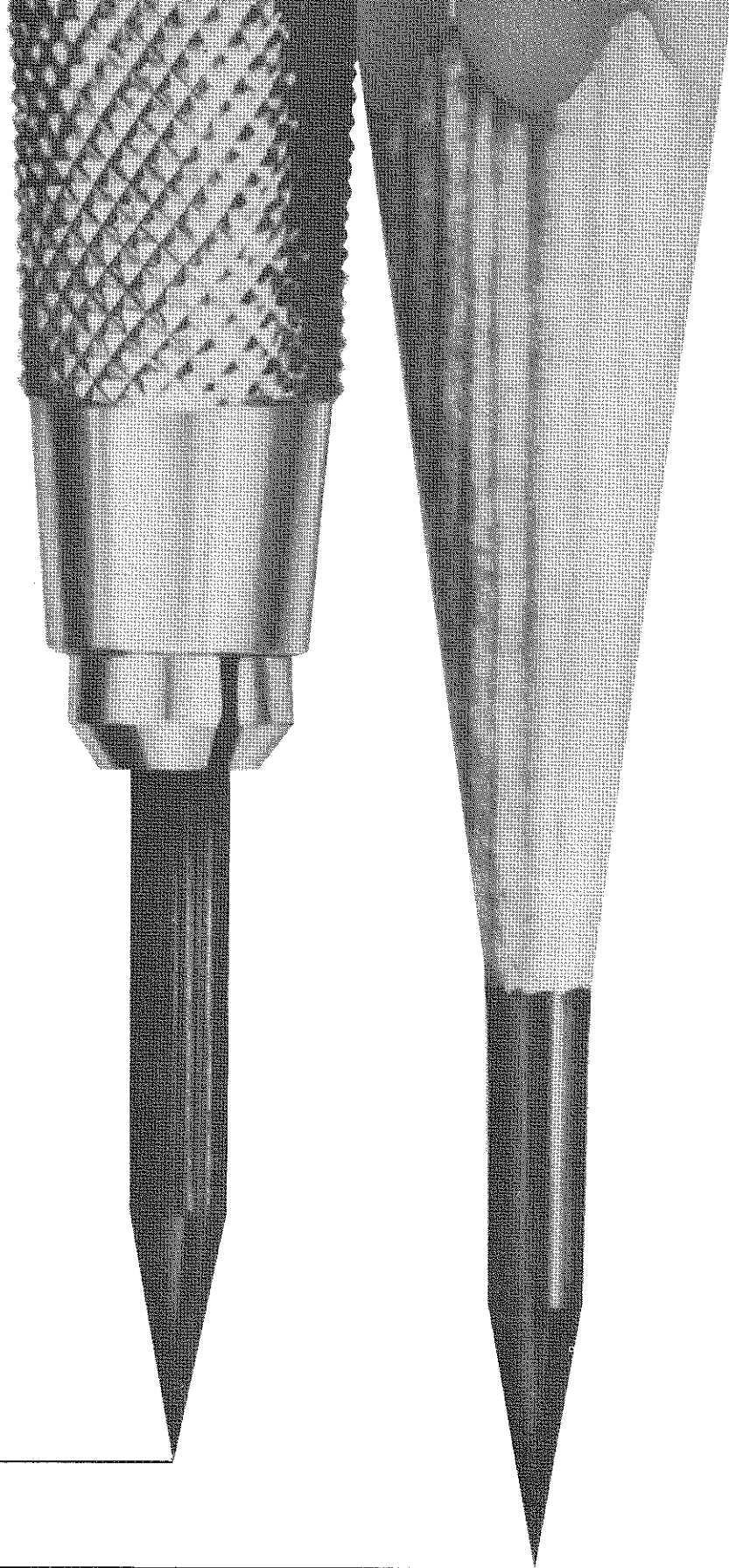
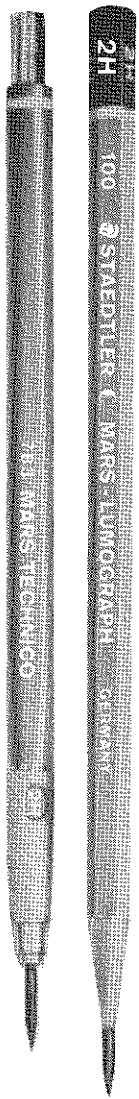

## Mars leads with Mars leads.

For complete catalog  
of The Mars Design Group  
write Dept. 55,  
J.S. Staedtler, Inc.,  
Montville, N. J. 07045