

Analysis of Blended and Multi-modal Instruction and its Effects on Spatial Visualization Ability

Diana Bairaktarova

Virginia Tech

Daron Williams

Virginia Tech

Petros J. Katsioloudis

Old Dominion University

Abstract

For the last decade, remedial spatial visualization training has been offered to first-year engineering students in traditional classroom settings where students attend class and interact face-to-face with an instructor and peers. An alternative to the traditional pedagogical approach is a multi-modal blended learning format that combines in-class instruction with videos that can be viewed at the student's convenience. The new setting affords students the opportunity to repeatedly revisit the basic instruction at the time and place of their choosing. This case study investigated student outcomes in a blended multi-modal Introduction to Spatial Visualization course that integrated video lectures; free-hand sketching techniques, sketching outdoors, Computer-aided-design (CAD) instruction, and 3D printed artifact manipulation. There was a statistically significant improvement on two (pre-to-post) spatial measures and performance on a drawing task.

Introduction

Spatial visualization skills refer to the ability to encode and maintain spatial information in working memory while transforming it (Carroll, 1993), which are valuable for several STEM fields. For example, the ability to mentally represent sectional views of objects is correlated with one's capacity for spatial visualization (Sorby, 2009). Considerable variation in spatial visualization ability exists across populations, putting some students at risk for compromised performance in engineering classes (Sorby, 2009). However, students weaker in the skill can be helped. Evidence for the contribution of spatial thinking to STEM fields, and for the malleability of spatial visualization skill, has motivated scientists and educators to call for systematic education of spatial thinking skills (National Research Council, 2006).

An alarming number of incoming engineering students need remediation in spatial visualization. For example, in the last five years at Virginia Tech, 6768 freshmen-engineering students were screened for low spatial skills using the Purdue Spatial Visualization Test: Revised [PSVT:R]. Approximately 30% of 6768 are identified as students with low spatial ability, meaning they scored 18 or below on the PSVT:R out of 30. Because of limited resources (classrooms, large class instructors, etc.), about 16% of these students enroll in a remediation course, and about 50% of these enrolled students drop the class by mid-semester (Virginia Tech Bursar office, 2018). Due to the issues of retention and the prevalence of low spatial ability, the course was redesigned to foster a different pedagogical model, which will be described in this article.

Background

The ability to use spatial thinking skills to translate between two-dimensional and three-dimensional views of an object or structure lies at the heart of engineering design practice. A vast amount of research shows that spatial thinking skills are critical for success in engineering education and practice (Miller & Bertoline, 1991; Peters, Chisholm, & Laeng, 1994; His, Linn, & Bell, 1997; Sorby & Baartmans, 2000; Humphreys, Lubinski, & Yao, 2003; Field, 2007; Webb, Lubinski, & Benbow, 2007; Sorby, 2009). It is particularly crucial for incoming engineering students to develop strong spatial visualization skills early in an academic program since spatial visualization skills have been shown to predict performance in a variety of sub-disciplines of engineering (Duesbury and O'Neil, 1996). The ability to reason through spatial transformations and cuts is vital for fundamental problems in engineering, such as visualizing the cross-sectional structure of materials (Duesbury & O'Neil, 1996; Gerson, Sorby, Wysocski, and Baartmans, 2001; Hsi, Linn, and Bell, 1997; Lajoie, 2003). Uttal and Cohen (2012) argue that without spatial training, students with low spatial skills will experience more difficulties learning the foundational STEM skills, possibly contributing to student attrition (Uttal and Cohen, 2012). Therefore, a remedial course serves to develop the skills early in the students' academic career to maximize their chance of success in future courses and careers.

Attrition in Undergraduate Engineering Courses

Attrition is a problem not foreign to engineering education. A systematic literature review of 50 studies investigating student attrition from engineering programs identified several reasons for students' withdrawal from engineering programs: classroom and academic climate, grades and conceptual understanding, self-efficacy and self-confidence, high school preparation, interest and career goals, and race and gender. Furthermore, the review summarizes retention studies as

well suggesting that retention can be increased by addressing one or more of these six factors (Geisinger & Raman, 2013).

Aud et al. (2011) found that almost 40% of first-year undergraduate students in the U.S. take at least one remedial course. Both students and educators have questioned the effectiveness and benefits of remediation. Bachman (2013) reported that many undergraduate mathematics students enrolled in remedial courses viewed remediation as a waste of time and a delay of required coursework. For many students, enrollment in remedial classes is associated with embarrassment and the stigma of being "...students who did not apply themselves" (Bachman, p. 25). The stigma associated with remediation has been reported in several relatively recent works (Best, 2005; Cox, 2009; Deil-Amen & Rosenbaum, 2002; Stuard, 2009). Complete College America (2012) questioned the effectiveness of remediation at four-year universities, claiming that the structure of remediation is designed for failure.

Students' lack of self-efficacy as engineers may also contribute to attrition. Bandura (1977) defined self-efficacy as "personal judgments of one's capabilities to organize and execute courses of action to attain designated goals" (Zimmerman, 2000). Zimmerman continued to note that evidence indicates several benefits associated with self-efficacy, including that self-efficacious students "participate more readily, work harder, persist longer," and suffer less emotionally when encountering obstacles, compared to their less-efficacious counterparts. We can summarize that students in remedial treatment programs may benefit from instruction in a class that focuses the mastery of basic skills, which also includes scaffolding and self-efficacy supports, the likes of which can be provided by the framework that follows.

Learning Theories

Scaffolded Knowledge Integration (SKI)

Blended Learning

Blended instruction as a delivery method offers the potential to emphasize the visible thinking aspect of the SKI framework by allowing the instructor to demonstrate concepts and techniques using video. The approach then leaves more time in class and labs for individual instruction. Balance is key in this regard. The instructor should not offer too much explicit instruction, as the idea of students visualizing and connecting new content to their existing knowledge helps them gradually take responsibility for their learning. The concept of growth through responsibility is related to Vygotsky's thoughts regarding the Zone of Proximal Development, cognitive apprenticeship, and general situative approaches to learning (Hsi, et al., 1997). If a student's hand is held the entire time through a curriculum, the students likely never reaches an experience where their Zone of Proximal Development is explored at the boundary. The result may be a student without a sufficient ability to identify his or her weaknesses.

This study is composed of students who have struggled with spatial visualization previously, so they can benefit from the repetition afforded by Learning Management System (LMS)-based videos outside of class time. Though some research indicates possible student outcome benefits of the flipped environment over a blended one, students seem to prefer the blended format, which can be particularly helpful with populations in which motivation is difficult or questionable (Clark, Kaw & Besterfield-Sacre, 2016). Finally, the flexible nature of the content, which

can be viewed anytime and anyplace, gives students some control over their learning, which empowers and motivates students to want to learn (Jones, 2009). The freedom and flexibility have been lauded as a driving force behind the rise of the MOOC (Irvine, Code & Richards, 2013), and it should also serve the target population of students well.

Methodology

A case study methodology was selected to assess the effectiveness of the blended and multi-modal instruction and address the question whether spatial visualization ability of engineering students can be enhanced with blended and multi-modal instruction (see Figure 1). The researchers designed a class that includes blended learning and multi-mode instruction. One-hundred-and-one students (54 female, 47 male) from two sections of a first-year engineering Introduction to Spatial Visualization course at a large public university in the Southeastern U.S. participated in this study. The course was designed for students with low spatial skills as measured by PRVT:R. To enroll in the Spatial Visualization course, students needed to score 18 or below on the Purdue Rotation Visualization Test: Revised (PRVT:R). The engineering advising office recommended the course to students in the 60th percentile of the whole cohort.

Considering the literature, our study was guided by three hypotheses:

1. The blended and multi-modal instruction method increases stu-

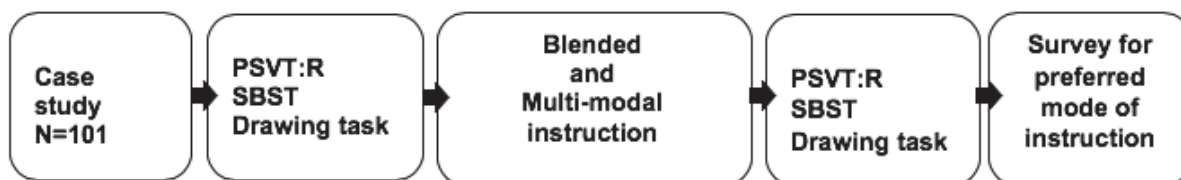

Figure 1. Research Design Methodology.

dents' spatial visualization skills as measured by the a) PRVT:R, b) SBST, and c) drawing task.

2. There are no gender differences in performance on the a) PRVT:R, b) SBST, and c) drawing task.
3. No significant differences exist concerning the preferred mode of instruction.

Blended and Multi-modal Instruction Enhanced Version of the Course

In the re-designed Introduction to Spatial Visualization course, the students moved through the course in three modules, beginning with sketching, proceeding to CAD, and finally to 3D object design and creation. Figure 2 presents each component of the course and how it adds to the traditional instructional mode.

For example, the video lectures served as students' tutorial for orthographic projection theory, sectional views, interpreting engineering drawings, and navigating the new user interface

and features of the CAD software. There was a considerable amount of material to cover in the online portion of the course, and a significant out-of-class effort was expected of all of the students. The students' job was to watch the videos and complete the assigned work diligently, in a manner that reflected the students' control over their learning.

When re-designing the course, the instructor also accounts for the alignment between the course content, learning theories, and the mode of instruction. This alignment is presented in figure 3.

Data Collection

We assessed students' spatial skills with the PRVT:R (Guay, 1977) and the Santa Barbara Solids Test (SBST) (Cohen & Hagarty, 2012). The tests were evaluated in previous and had been used in prior research on the role of spatial skills for engineering spatial visualization training (Author A, 2017; Cohen & Hagarty, 2012; Maeda, Yoon, Kim-Kang, & Imbrie, 2013). The tests were provided online to students at the beginning and

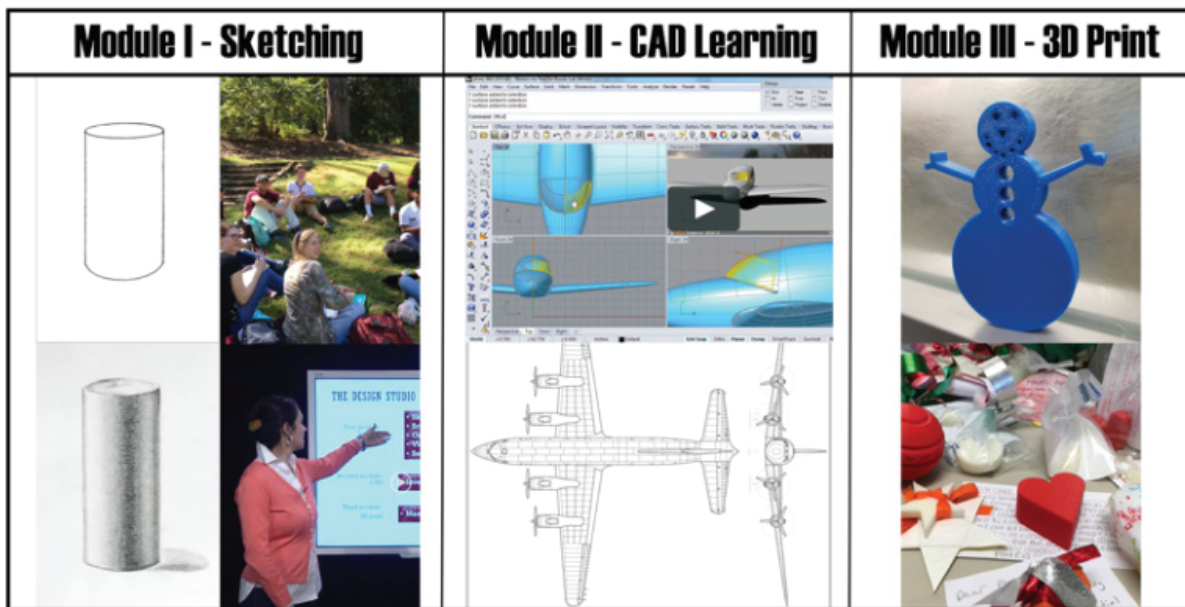

Figure 2. Progression of the course.



Course content	Relationship to theory	Mode of instruction
Design Graphics foundation topics	<ul style="list-style-type: none"> Recorded lectures with worked examples <i>make thinking visible</i>. Students' flexibility of access is an example of <i>learner autonomy</i>. 	Video lectures and techniques 
Technical drawings and free-hand sketching	<ul style="list-style-type: none"> Worked problems and video annotations <i>make thinking visible</i>, but also <i>present a variety of spatial strategies</i> by approaching similar problems in different ways. 	Video-lectures and video free-hand techniques 
Outdoor sketching	<ul style="list-style-type: none"> Another example of <i>presenting a variety of spatial strategies</i>, as outdoor sketching session required the use of different spatial strategies than initial freehand sketches. The group environment allowed students and instructor to <i>take advantage of social supports</i>. 	Face-to-face instruction in an outdoor setting 
CAD	<ul style="list-style-type: none"> Another example of <i>making learning visible</i> and delivery of content via a <i>variety of spatial strategies</i>. 	Video Inventor instruction and step-by-step guided CAD instruction for 6 basic solids 
3D printed artifact manipulation and donation of 3D printed Christmas ornaments to local Appalachian High School and Senior Citizens Home	<ul style="list-style-type: none"> Another example of the <i>variety of spatial strategies</i> presented. The ability to design their own object gave students <i>learner autonomy</i>. <i>Empowering</i> students to teach others about engineering and by applying their learning to a good cause. 	In-class instruction on additive manufacturing In-class Instruction and a step-by-step guide on developing slt. file for 3D print for each basic solid and students creations 

Figure 3. Alignment of course content, learning theories, and mode of instruction.

end of the course. The PRVT:R measure was used as an assessment tool in both the traditional and blended multi-modal classrooms. In both cases, students had 20 minutes to complete the test. The validity of the SBST to predict performance in a mechanics of materials course was established by Ha & Brown (2017). The students completed the SBST measure in 12 minutes on average. In the first week of class, before instruction, students also completed drawing set (See Figure 5). Students completed the same PRVT:R, the SBST scale and drawing set at the end of the semester as well. The PSVT-R consists of 30 questions that require participants to solve spatial problems related to rotations and isometric views (Guay, 1977). Figure 4 shows an example of PSVT:R question.

The SBST is a 30-item multiple-choice test in which participants are asked to solve spatial problems related to cross-sectional views (Figure 5). Half of the figures have cutting planes that are orthogonal (horizontal or vertical) to the figure's main vertical axis; the other half have cutting planes that are oblique to the main vertical axis (Cohen & Hegarty, 2012).

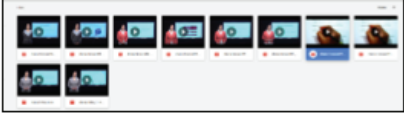
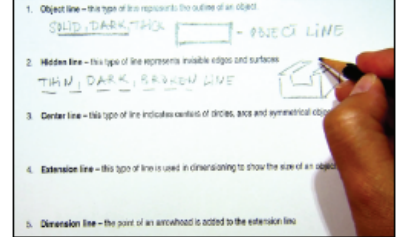
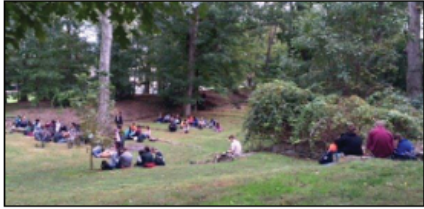
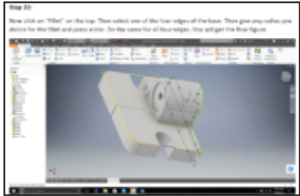
As part of a drawing assignment, students needed to draw sectional views of six mechanical objects manually. They were asked to create the sectional views of these mechanical objects using a cutting plane as shown in the Flange example in figure 6. Students were asked to sketch the sectional view of the part below by using the identified cutting plane line to do the imaginary cut. The scoring method, as used by Ingale and colleagues, gives one point for each correct feature in the cross-sectional drawing, with potential total score for drawing ranging from 0 to 5 (Ingale, Srivasavan, Bairaktarova, 2017).

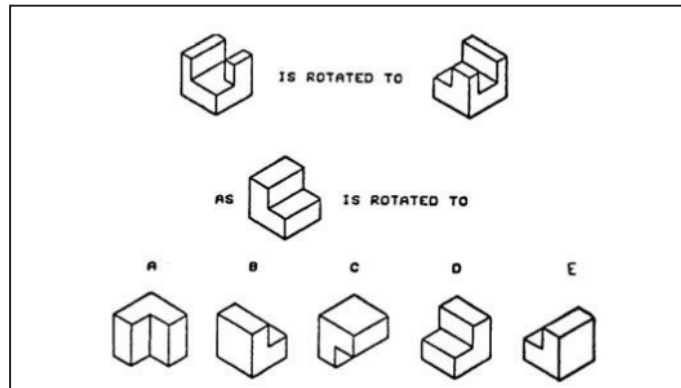

Figure 4. A sample problem from the Purdue Spatial Visualizations Test: Rotations.

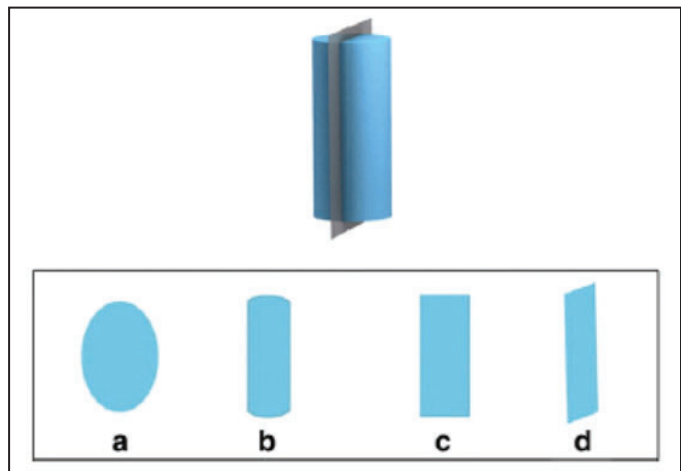

Figure 5. A sample problem from the Purdue Spatial Visualizations Test: Rotations.

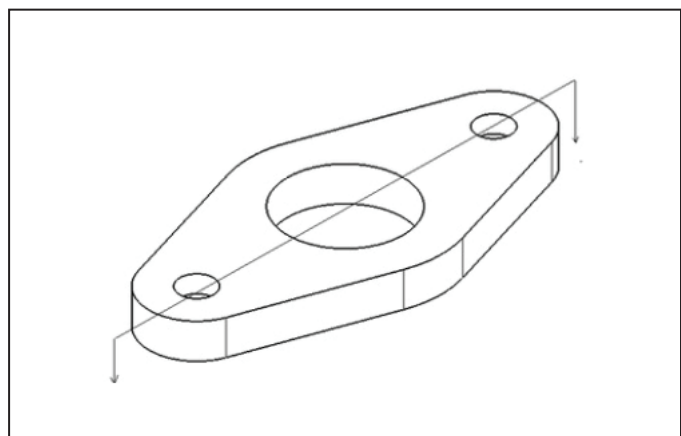

Figure 6. An example of a 3D drawing of a Flange.

At the end of the semester, we also assessed students' learning experiences with a survey that asked them to rate the preferred mode of instruction. The survey used questions with Likert scale ranging from 1 (not helpful at all) to 5 (extremely helpful). The survey was part of the students' final report (course reflection), and it was provided online via the course website.

Analysis

To test if there were overall gains, we used a repeated-measures ANOVA with test time (i.e., pre-test and posttest) as the repeated within-subjects factor. We also calculated the normalized gains, "G-scores," "a rough measure of the effectiveness of a course in promoting conceptual understanding" (Hake, 1998). The measure has become the standard measure for reporting scores on research-based concept inventories. Hake (1998) defined the average normalized gain as: $g = (\text{post}) - (\text{pre}) / 100 - (\text{pre})$, where brackets indicate class averages. This measure is commonly described as the amount students learned divided by the amount they could have learned. G-scores were used to compare across genders.

Results

All pretest, posttest, and drawing task scores met statistical assumptions of normal distribution, linearity, and homoscedasticity. Therefore,

the ANOVAs were found to be conducted. The summary of the statistically significant results are summarized in Table 1.

Pre-to-post PSVT:R

Students showed significant increase in performance on the PSVT:R from pre-test ($M = .49$, $SD = .09$) to post-test ($M = .71$, $SD = .15$), $F(1, 99) = 194.14$, $p < .001$, partial $\eta^2 = .662$. The significant increase means the alternative hypothesis is taken for H1 regarding the PSVT:R. Across genders, there were no significant difference in PSVT:R performance $F(1, 99) = 2.69$, $p = .104$, partial $\eta^2 = .026$. Therefore, the null hypothesis is accepted for H2 in terms of the PSVT:R. The class average normalized gain (g) was 0.42.

Pre-to-post SBST

Students showed a significant increase in performance on the SBST pre-test ($M = .48$, $SD = .17$) to post-test ($M = .64$, $SD = .09$). Significant main effect on plane $F(1, 99) = 89.3$, $p < .001$, partial $\eta^2 = .474$; and significant main effect on structure $F(2, 98) = 3.34$, $p = .039$, partial $\eta^2 = .064$. While there were no effect of gender across plane $F(1, 99) = 1.67$, $p = .199$, partial $\eta^2 = .016$ and structure $F(2, 98) = .303$, $p = .74$, partial $\eta^2 = .006$, there was a significant interaction between plane and structure $F(2, 98) = 96.17$, $p < .001$, partial $\eta^2 = .662$, and significant 3-way interaction between plane, structure, and gender $F(2, 98) = 5.15$, $p = .007$,

Table 1
 Summary of statistically significant results.

Comparison	F	p	partial η^2
Pre-post PSVT:R	194.14	< 0.001	0.662
Pre-post SBST – on plane	89.3	<0.001	0.474
Pre-post SBST – on plane & structure	96.17	<0.001	0.662
Pre-post SBST – on plane & structure & gender	5.15	0.007	0.095
Pre-post Drawing Cross-section	130.10	< 0.001	0.568

partial $\eta^2 = .095$. Therefore, the null hypothesis for H1 is rejected and partially accepted for H2 due to the interaction between plane and structure. The class average normalized gain (g) was 0.25.

Pre-to-post Drawing task

Students showed significant increase in performance on Drawing Cross-section pre-test ($M = .52$, $SD = .14$) to post-test ($M = .75$, $SD = .17$), $F(1, 99) = 130.10$, $p < .001$, partial $\eta^2 = .568$. There was no significant effect of gender on improvement in drawings $F(1, 99) = .821$, $p = .367$, partial $\eta^2 = .008$. Again, the null hypothesis is rejected for H1 and accepted for H2. The class average normalized gain (g) was 0.57.

Students preferred mode of instruction

Results from the survey indicated that students identified all offered modes of instruction similarly helpful, rating all five modes of instruction in range of 3.81 to 4.34 with no significant differ-

ence between the modes. The means sorted by type of instruction are shown in Figure 7. Further, there was no significant difference between female and male students in the preferred mode of instruction. Therefore, we accept the null hypothesis for H3.

Discussion

In this study, we investigated student outcomes in a blended multi-modal *Introduction to Spatial Visualization*. The course integrated video lectures; free-hand sketching techniques; outdoors sketching; CAD instruction; and 3D printed object manipulation. The design of the course builds upon the Scaffolded Knowledge Integration (SKI) framework, to make the best possible effort to reach all the students in the course. Participants were students with low spatial skills as identified on the PSVT:R. As each of the two tests and the drawing task was attempted twice, we collected the data on six occasions. Also, we assessed

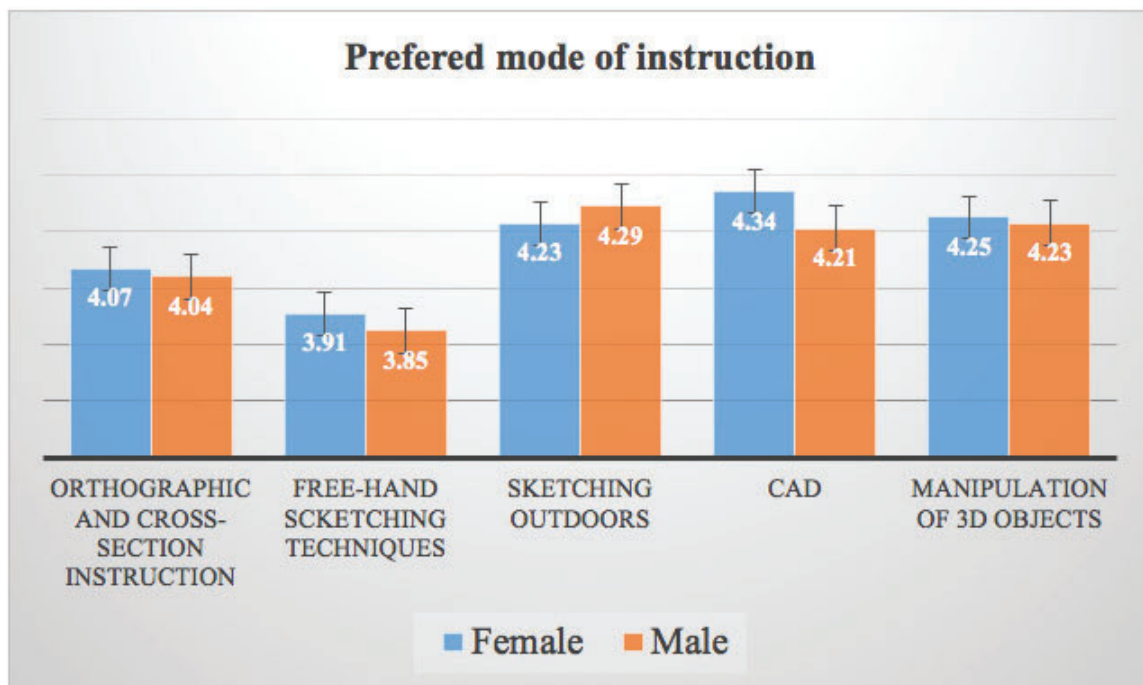

Figure 7. Comparison of students' preferred mode of instruction.

Though we approached this topic as an extension of the work of Sorby and Baartmans (2000), as structured by the SKI and SRL frameworks, we recommend that more work is needed as it pertains specifically to student academic motivation, particularly in remedial contexts. Future work could include pre- and post-test comparisons that include student perceptions of academic motivation and self-efficacy, as well as their perceptions of any “stigma of remediation” that may exist as they enter this course and then again as they complete it. Another future study of ours is the full online integration of the course.

Conclusions

Our study findings demonstrated the effectiveness of using blended and multi-modal holistic approach in improving students’ spatial visualization performance. The novelty in our instruction is the combination of delivering content online, on-demand, and the different modes of instruction designed according to the SKI framework to enhance students’ spatial visualization ability. We found statistically significant improvement on students’ performance gains in the context of first-year engineering Spatial Visualization course. The study findings extend research on blended learning and multi-modal instruction in two ways: 1) by showing that supporting blended learning and multi-modal instruction is an effective means to support engineering students with low spatial visualization skills; 2) by showing that a blended learning and multi-modal instruction enhance spatial visualization ability across genders. Further, the success of the blended format implies spatial visualization training can be accessed online and by students across disciplines.

Acknowledgments

This work was supported by 4-VA Initiative Course Redesign grant. We thank the Technology-enhanced Learning and Online strategies (TLOS) personnel for their constant support.

References

- Bachman, R. (2013). Shifts in attitudes: A Qualitative exploration of students’ attitudes towards efforts of remediation. *Research in Teaching and Developmental Education*, 29 (2), pp. 14-29.
- Bandura, A. (1977). Self-efficacy: Toward a unifying theory of behavior change. *Psychological Review*, 84(2), 191-215
- Barnard-Brak, L., Paton, V. O., & Lan, W. Y. (2010). Profiles in self-regulated learning in the online learning environment. *The International Review of Research in Open and Distributed Learning*, 11(1), 61-80.
- Best, L. (2005). Crossing the boundaries: A case study of one remedial student’s transformation into a college writer. *Research in Teaching and Developmental Education*, 22(1), pp. 27-42.
- Cohen, C. A. & Hegarty, M. (2012). Inferring cross sections of 3D objects: A new spatial thinking test. *Learning and Individual Differences*, 22(6), 868-874.
- Complete College America (2012). *Remediation: Higher education’s bridge to nowhere*. Washington DC.
- Cox, R. (2009). *The college fear factor: How students and professors misunderstand one another*. Cambridge, MA: Harvard University Press.
- Carroll, J.B. (1993). *Human cognitive abilities: A survey of factor analytic studies*. Cambridge University Press Cambridge; New York.
- Clark, R. M., Kaw, A., & Besterfield-Sacre, M. A. R. Y. (2016). Comparing the Effectiveness of Blended, Semi-Flipped, and Flipped Formats in an Engineering Numerical Methods Course. *Advances in Engineering Education*, 5(3).
- Deil-Amen, R., & Rosenbaum, J.E. (2002). The unintended consequences of stigma-free remediation. *Sociology of Education*, 75 (3), pp. 249-268.

- Duesbury, R. T. (1996). Effect of type of practice in a computer-aided design environment in visualizing three-dimensional objects from two-dimensional orthographic projections. *Journal of Applied Psychology*, 81(3), 249.
- Eliot, J., & Smith, I. M. (1983). *An international directory of spatial tests*. Windsor, Berkshire, UK: NFER-NELSON Publishing Company. (Out of print; available at <http://drc.ohio-link.edu/handle/2374.OX/30660>)
- Feng, J., Spence, I., & Pratt, J. (2007). Playing an action video game reduces gender differences in spatial cognition. *Psychological Science*, 18(10), 850–55.xxx23xxx
- Field, B.W. (2007). Visualization, intuition, and mathematics metrics as predictors of undergraduate engineering design performance. *Journal of Mechanical Design*, 129(7), pp. 735– 743.
- Guay, R. (1977). Purdue Spatial Visualization Test-Visualization of Views. Purdue Research Foundation, West Lafayette, IN.
- Ha, O., & Brown, S. A. (2017, June), *Spatial Reasoning Difference between Civil and Mechanical Engineering Students in Learning Mechanics of Materials Course: A Case of Cross-sectional Inference*. Paper presented at 2017 ASEE Annual Conference & Exposition, Columbus, Ohio.
- Hsi, S., Linn, M. C., and Bell, J. E. (1997). The role of spatial reasoning in engineering and the design of spatial instruction. *Journal of Engineering Education*, 86(2), pp. 151–58.
- Humphreys, L. G., Lubinski, D., & Yao, G. (2003). Utility of predicting group membership and the role of spatial visualization in becoming an engineer, physical scientist, or artist. *Journal of Applied Psychology*, 78(2), pp. 250–261.
- Ingale, S., Srivasavan, A., & Bairaktarova, D. (2017). CAD Platform Independent Software for Automatic Grading of Technical Drawings. *Proceedings of the ASME 2017 International Design Engineering Technical Conferences & Computers and Information in Engineering Conference IDETC/CIE 2017*, August 6-9, 2017, Cleveland, OH, USA.
- Irvine, V., Code, J., & Richards, L. (2013). Realigning higher education for the 21st century learner through multi-access learning. *Journal of Online Learning and Teaching*, 9(2), 172.
- Jones, B. D. (2009). Motivating students to engage in learning: The MUSIC model of academic motivation. *International Journal of Teaching and Learning in Higher Education*, 21(2), 272-285.
- Kirschner, P. A. (2017). Stop propagating the learning styles myth. *Computers & Education*, 106, 166-171.
- Knoll, A. R., Otani, H., Skeel, R. L., & Van Horn, K. R. (2017). Learning style, judgements of learning, and learning of verbal and visual information. *British Journal of Psychology*, 108(3), 544-563.
- Linn, M. C. (1995). Designing computer learning environments for engineering and computer science: The scaffolded knowledge integration framework. *Journal of Science Education and technology*, 4(2), 103-126.
- Miller, C. L., & Bertoline, G. R. (1991). Spatial visualization research and theories: Their importance in the development of an engineering and technical design graphics curriculum model. *Engineering Design Graphics Journal*, 55(3), pp. 5–14.
- National Research Council (2006). Learning to think spatially: GIS as a support system in K-12 curriculum. Washington: *National Research Council Press*.
- Peters, M., Chisholm, P., & Laeng, B. (1994). Spatial ability, student gender, and academic performance. *Journal of Engineering Education*, 83(1), pp.1–5.
- Sorby, S. A. (1999). Developing 3D spatial visualization skills. *Engineering Design Graphics Journal*, 63(2), 21–32.

