

The Journal of Engineering Graphics

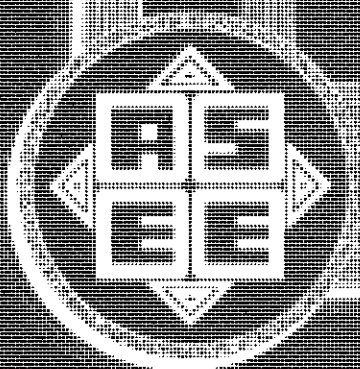

November (Fall) 1966 Vol. 30, No. 3, Series 90

PUBLISHED BY THE AMERICAN SOCIETY OF MECHANICAL ENGINEERS

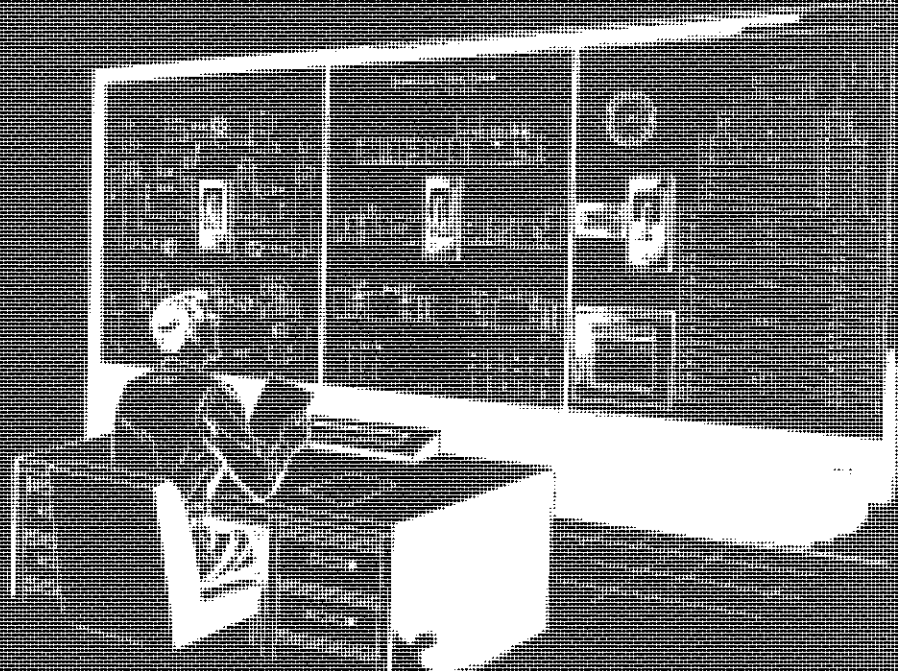

ASPEN, COLORADO

PHOTO BY: BERKO



846 ELATI STREET • BLDG. 24
DENVER, COLORADO 80204
TEL. AREA CODE 303-534-4251
CABLES: GRAMPORCOM

Frank Oppenheimer, President



GRAMERCY GUILD GROUP , INC.

Extends best wishes to all our friends

Our drawing instruments, particularly the Riefler with the Quick-Action Bow have been very popular again this year.

We are very happy to have the opportunity to serve the Educational Field.

IMPORTERS OF GRAMERCY GUILD GROUP AND  CUSTOM-FINISHED DRAWING INSTRUMENTS

ESTABLISHED 1842



The Journal of Engineering Graphics

NOVEMBER (FALL) 1966 VOLUME 30, NUMBER 3, SERIES 90

The views expressed by the individual authors do not necessarily reflect the editorial policy of the Journal of Engineering Graphics or represent the official stand of the American Society for Engineering Education or the Engineering Graphics Division. The editors make reasonable effort to verify the technical correctness of material published; however, final responsibility for technical accuracy rests with individual authors.

|| ||
EDITORIAL STAFF
|| ||
EDITOR

Earl D. Black
General Motors Institute
Flint, Michigan 48502

|| ||
CIRCULATION MANAGER
and
TREASURER

James H. Earle
Texas A&M University
College Station, Texas 77840

|| ||
ADVERTISING MANAGER

Kenneth E. Botkin
MGEL 104A
Purdue University
W. Lafayette, Ind. 47907

|| ||
ASSISTANT EDITORS

William B. Rogers
Dept. of Earth, Space and
Graphic Sciences
United States Military Academy
West Point, New York 10996

E. E. Sautter
General Motors Institute
Flint, Michigan 48502



Published for teachers and others interested in Engineering Graphics. It is published three times per year -- Fall (November), Winter (February), and Spring (May).

|| ||
The subscription rates are: \$2.00 per year in the United States (single copies 75 cents). Foreign rates upon request.

CONTENTS

ARTICLES

- Automation of Design with Modern Techniques Jacob H. Sarver . . . 11
- The Thought-Model Method of Teaching Spatial Visualization A. S. Levens 13
- Fundamental Theorems of the Geometry of Four Dimensions. Louisa Bonfiglioli . . 15
- Transposing Nomograms to Slide Rules L. M. Weiner. . . . 17
- The Summer Drafting Institute at Texas A&M University. Gary Johnson . . . 19
- Descriptive Geometry, A Self Dependent Spatial Science T. D. Pozniak 21

DEPARTMENTS

- Editor's Board - Engineering Graphics - Static or Dynamic 5
- Officers Page. Eugene G. Paré . . . 8
- Officers and Committees, 1966-1967. 8
- Graphite Dust - Ford Sponsors Faculty Work Residence, Membership Committee Report 10
- Citations - 1966 Distinguished Service - Hammond Receives Army Legion of Merit Award - Oppenheimer Becomes Member of Aspen Institute for Humanistic Studies - Louisa Bonfiglioli Receives Descriptive Geometry Award. 4
- Perspective - The Educational Value of Graphics Frank A. Heacock . . 23
- In Memoriam (Frank A. Heacock & James J. Devine) 26
- File to File - Application of Desargues' Theorem - Rocket Drawing Problem - Answer to Problem 24
- Information for Authors 43

COMMITTEE REPORTS

- Membership - Awards - 10, 46

Available For Examination Spring 1967

TECHNICAL DRAWING, Fifth Edition

By the late Frederick E. Giesecke, the late Alva Mitchell; revised by Henry Cecil Spencer, on leave, the Illinois Institute of Technology, and Ivan Leroy Hill, the Illinois Institute of Technology

Since the original publication of the First Edition, TECHNICAL DRAWING has been used by more than two and a half million students. In the painstaking process of constant revision, the authors have sought and achieved excellence: excellence in illustration and example; excellence in definition and explanation; and excellence in the production of a book which includes *all* of the basic graphics instruction needed by the engineer, the scientist, or the draftsman.

In this Fifth Edition, the authors have thoroughly revised all material to accord with the current *ASA Y14 American Standard Drafting Manual*, including the latest American Standard on *Dimensioning and Tolerancing for Engineering Drawings*. In addition, modern trends in engineering education have been taken into account. Leading engineers and manufacturers, mindful of the role of TECHNICAL DRAWING in the education of future engineers and scientists, have helped the authors incorporate the most current industrial thinking in this new edition. One example is the emphasis placed upon decimal dimensioning in the illustrations and problems. Technical sketching is also emphasized. Four entirely new chapters have been included: Electronic Diagrams, Alignment Charts, Empirical Equations, and Graphical Mathematics.

A text that has become *the* classic, the Fifth Edition of TECHNICAL DRAWING continues to uphold the standard of excellence set and maintained by the previous editions.

To accompany TECHNICAL DRAWING

TECHNICAL DRAWING PROBLEMS, Series I, Third Edition

By the late Frederick E. Giesecke, the late Alva Mitchell, and Henry Cecil Spencer; revised by Henry Cecil Spencer

Available Spring, 1967

TECHNICAL DRAWING PROBLEMS, Series II, Second Edition

By Henry Cecil Spencer

1961, 91 sheets, paper, \$5.25

TECHNICAL DRAWING PROBLEMS, Series III

By Henry Cecil Spencer and Ivan Leroy Hill

1960, 80 sheets, paper, \$4.50

Write to the faculty service desk for examination copies.

THE MACMILLAN COMPANY 866 Third Avenue, New York, N.Y. 10022

DESCRIPTIVE GEOMETRY, Third Edition

By E. G. Paré, Washington State University, R. O. Loving and I. L. Hill,
both of the Illinois Institute of Technology

Now in its third edition, DESCRIPTIVE GEOMETRY richly merits its outstanding reputation as an effective text for teaching the science of graphic communication. It also provides a broad orientation to those engineering concepts that should be inculcated early in the student's progress toward a career as a professional engineer.

Among the many revisions and refinements in this edition, the most significant is the inclusion of full-size, student self-testing problems which provide a college-level system of programmed evaluation. To facilitate a constant check on the student's comprehension of pertinent fundamentals, these projects are presented at the conclusion of chapters. For maximum convenience and time economy, they may be solved directly in the text. Carefully delineated solutions are shown in Appendix IV.

Other features of the third edition: more than 300 new and revised illustrations; new true-and-false questions at the ends of chapters; revised problems; and an updated treatment of vectors.

Throughout the book, solution illustrations have been broken into steps to make the construction easier to follow. Considerable care has been exercised to provide solutions in pictorial form whenever they can be used to aid visualization.

1965, 383 pages, \$6.50

DESCRIPTIVE GEOMETRY WORKSHEETS, Series A, B, and C

Designed to accompany the authors' DESCRIPTIVE GEOMETRY or any other standard text featuring the direct method, each of these three workbooks consists of 24 groups of problems. The organization in all three is similar; each worksheet contains from one to six problems covering the drafting and layout work of standard courses, with sufficient material for one laboratory period. Because each workbook offers a completely different set of problems, they may be used by turns to provide flexibility and variety.

Series A, Second Edition 1959, 76 sheets, paper, \$4.65

Series B, Second Edition 1966, 76 sheets, paper, \$4.65

Series C, Second Edition Available in January

Keys to each series are provided gratis.

Write to the faculty service desk for examination copies.

THE MACMILLAN COMPANY 866 Third Avenue, New York, N.Y. 10022

Editors' Board

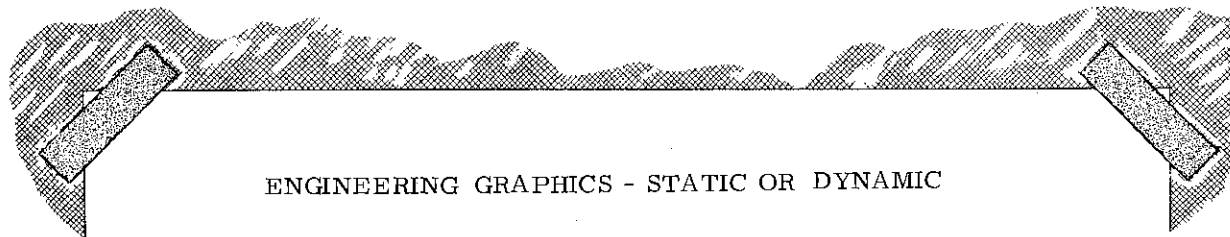

ENGINEERING GRAPHICS - STATIC OR DYNAMIC

Engineering is a dynamic profession that continually implements the products of basic research as fast as new concepts and ideas become available. Keeping up-to-date involves being grounded in the past, coordinated with the present, and an appreciation and constant awareness of the future. It is comparatively easy to steep ourselves in the methods and techniques used in the past. It is more difficult to stay abreast of the changes going on in the present. To make accurate estimates of what the engineer will need and use in his professional work of the future is a formidable task indeed.

Tomorrow, science will have moved another giant step forward and we of the Division of Engineering Graphics must keep pace. In this era of rapid change and development there is a definite need for a thorough understanding of the basic fundamentals of engineering graphics. Engineering graphics serves as a spring board for individual advancement by furnishing an effective means of communication which can be used extensively by both the engineer and scientists. But the new tools used in engineering today may change the approach and even modify fundamental principles. What was once important in engineering graphics may become a mere by-product of the profession tomorrow.

Knowledge with ability, systematic and logical thinking, and the capacity to make proper judgments or deductions provides the engineer with the means of successful performance in engineering practice. There must be more to education in engineering graphics than the mere use of pencils, instruments and drawing equipment. However, scientific knowledge alone will not build a better mousetrap. Analysis of the needs in graphics by the engineer cannot adequately be undertaken until we examine recent developments in industry.

Industry and engineering education have mutual stakes in our future. Every thinking man must seek after new sources of knowledge and document his findings in order that he may not only understand any event that takes place, but his knowledge will help him in doing his part of the teamwork required in industry.

The engineer must be able to communicate his ideas to others. Written and spoken language alone often possess connotations and overtones which suggest more than they usually say. Because an employee misunderstands instructions is no sign that he is stupid, but rather that there

is a lack of complete communication. There must be a matching of educational background and knowledge for an effective meeting of minds between individuals on the production team. If the scientist wishes to take us to cloud nine, he must be able to communicate with us in terms which we can understand simply, accurately, and unmistakably. Engineering graphics can and must provide this means of communication.

In his long and unfinished struggle to master the universe and its natural laws, man has progressed by processing a steady stream of knowledge. Great discoveries are rarely the work of a single individual, but rather the culmination of the work of his predecessors who have faithfully documented their findings. Past knowledge and developments often give the recognized individual a basis for discovery.

Strict chronological order of events mixes great and small incidents and combines undesigned happenings that occur only once with permanent truths and nature's laws. The engineer is also confronted by man's prejudices, fads and fancy, and the engineer must untangle this disorder of events and happenings. He must rearrange materials by design with selected shapes, sizes, finishes and quantity to produce a product which man will recognize as desirable and accept as a part of his necessary personal needs.

The engineer must be able to make many practical applications of his knowledge. The more completely we are able to educate each man or woman, the greater will be our productive capacity for competing with other nations of the world. Every innovation in manufacturing starts with an idea. The closer an idea comes to solving a current problem, the more quickly it will come to be implemented and accepted. Furthermore, the engineer who has just solved a technical problem has not completed his job until he has convinced his supervisor of its validity and worth. The proper use of engineering graphics will help him greatly in communicating with and convincing his boss.

Improvement in the design of machines and processes depends primarily on detailed and accurate drawings of the designer's concepts. Often the designer himself is required to follow his concept from the inception of the idea until it comes off the production line in its final form.

Continued on Page 28

JAMES S. RISING GETS
1966 DISTINGUISHED SERVICE AWARD
of the
Engineering Graphics Division, ASEE



JAMES SINCLAIR RISING, son of Jay and Cora Sinclair Rising, was born in Kanona, New York, on June 7, 1903. After receiving his B.S. in Mechanical Engineering at Rensselaer Polytechnic Institute in 1925, he taught at his alma mater until 1945, meanwhile receiving an M.S. at New York State Teachers College and practicing engineering at the Eddy Valve Company and Ford Motor Company. In 1945 he was appointed professor and head of the Department of Engineering Drawing at Syracuse University. A move to the middle west followed in 1951 when he became professor and head of the Department of Engineering Graphics at Iowa State University where he still serves in that capacity. He is currently chairman of the American Standards Association Sub-committee on Projection Standards and Space Geometry.

Through his authorship of books on engineering graphics, and his activities in the Engineering Graphics Division of ASEE and the parent society itself, Professor Rising's influence has been felt far beyond the limits of his own campus. The Engineering Graphics Division has been fortunate to have an academic statesman of his caliber in its membership. He has served the Division with great effectiveness on numerous important committees, and ultimately as Chairman of the Division in 1958-59. At a time when all engineering disciplines, including our own, have been undergoing searching self-examination, his voice has been one of authority and wisdom.

Continued on Page 26

CITATION

Lieutenant Colonel Robert H. Hammond, formerly assigned at the U. S. Military Academy as an associate professor with the Department of Earth, Space and Graphic Sciences, retired here recently after more than 25 years in the Army. He taught at the Military Academy since 1951.

Colonel Hammond, awarded the Legion of Merit at the retirement ceremony, served as Chairman of the Division of Engineer Graphics of the American Society for Engineer Education (ASEE) from 1964-1965. He is also a member of the Executive Committee, Council of Technical Divisions, ASEE.

Continued on Page 26



Lieutenant Colonel Robert H. Hammond, left, accepts congratulations from Brigadier General John R. Jannarone, Dean of the Academic Board at the U. S. Military Academy, after receiving the Legion of Merit medal at retirement ceremonies. Col. Hammond, formerly and assistant professor in the Department of Earth, Space and Graphic Sciences, retired from West Point recently after more than 25 years in the Army.

(U. S. Army Photo)

A complete program for engineering graphics

FUNDAMENTALS OF THREE-DIMENSIONAL DESCRIPTIVE GEOMETRY

by STEVE M. SLABY, Princeton University

Textbook

Just published in June and already in wide use in technical institutions, colleges, engineering schools, and universities throughout the country, this textbook presents the basic concepts of three-dimensional descriptive geometry and, in a logical and sequential manner, shows their practical applications through orthographic examples and construction programs. Color is used—for the first time in a descriptive geometry text—to clarify relationships among lines and to identify planes in constructions. Distorted labels maintain a consistent three-dimensionality throughout the illustration program. Sample quizzes and examinations and 135 practice problems reinforce the text presentation. "The best text on descriptive geometry yet to be published."—R. Kenneth Jacobs, Georgia Institute of Technology.
383 pages, \$7.50

Instructor's
Manual

INSTRUCTOR'S MANUAL

Presents a course syllabus, lecture outlines, and solutions to all the problems in the textbook. Available to instructors who have adopted FUNDAMENTALS OF THREE-DIMENSIONAL DESCRIPTIVE GEOMETRY for basic class use. Publication: Fall, 1966

WORKBOOK FOR FUNDAMENTALS OF THREE-DIMENSIONAL DESCRIPTIVE GEOMETRY

by STEVE M. SLABY and H. SANFORD GUM, College of San Mateo.

Contains problems derived from the text, with a detachable transparent sheet of grid-lined paper bound between each page on which the student can sketch his preliminary solution. Grid-lines are printed in the same color used in the textbook. Separate Solutions Manual in preparation. Spiralbound. 72 sheets with 96 drawings, plus overlays. \$5.95

ALTERNATE WORKBOOK FOR FUNDAMENTALS OF THREE-DIMENSIONAL DESCRIPTIVE GEOMETRY

by H. LANE CALENDAR and W. J. BROWN, Rutgers University.

With Solutions Manual.

Publication: January, 1967

APPLIED PROBLEMS FOR FUNDAMENTALS OF THREE-DIMENSIONAL DESCRIPTIVE GEOMETRY

by ROBERT SEID, Bronx Community College of the City University of New York.

With Solutions Manual.

Publication: Spring, 1967

These new workbooks, together with the one by Professors Slaby and Gum which was published with the text, give the instructor a wide choice of problems for use with FUNDAMENTALS OF THREE-DIMENSIONAL DESCRIPTIVE GEOMETRY. The ALTERNATE WORKBOOK by Professors Calendar and Brown provides practical problems, including some that introduce vector notation and operations. It also discusses some topics—topology, for example—that are not covered in the text. The APPLIED PROBLEMS by Professor Seid contains simple problems illustrating particular theories, followed by problems involving practical applications of the theory in engineering terms. The workbook by Professors Slaby and Gum offers problems that work out more purely theoretical concepts.

EXAMINATION COPIES ON REQUEST.



Harcourt, Brace & World, Inc.
New York / Chicago / San Francisco / Atlanta

3
Workbooks
with
Solutions
Manuals



Officers' Page

Eugene G. Paré

Vice Chairman

American Society for Engineering Education
Division of Engineering Graphics
Officers and Committees
1966-1967

For too many years our engineering profession and colleges have experienced a steady decline in the percentage of young people attracted to engineering. This trend has materialized in spite of the fact that the quality of engineering education and the financial rewards of engineering employment are second to none. If the product is sound, then the advertising must indeed be faulty.

It is time that the engineering profession begins to realize that its rusty public image needs much polishing if it hopes to acquire the public esteem warranted by its accomplishments. It is time, also, and it is essential that our engineering colleges expand their efforts to attract the qualified students needed to meet the insatiable requirements of our industrial complex. Above all, the major spokesman for engineering education, our American Society for Engineering Education, must be strengthened in order that it can exercise more effectively its public relations function.

Other engineering disciplines have interests in more than one national engineering society, while the Engineering Graphics Division has directed its complete support to ASAE. Since the welfare of the Engineering Graphics Division rests in good measure on the strength of the parent society, our support must not waiver but must be expanded when needed. Now, perhaps the parent organization has not always seemed mutually solicitous but a substantial measure of that difficulty could well be ours. For example, we have not yet made available for a top elective position on their administrative council one of our own experienced educators. That situation must and shall be rectified soon.

In a broader sense we must all, at every level, provide our experience and advice at the policy-making councils so that we are not always left at the starting gate, only to react to the well-meaning but ill-conceived guidelines promoted by harrassed administrators and goals directors too far removed from beginning undergraduate education and the realities of our specialty. They are apparently unaware of the innovations already introduced in our engineering orientation and graphics programs; or perhaps they are wiser than we think and are merely attempting to stir the apathetic and the weary.



OFFICERS

- Chairman - E. W. Jacunski, University of Florida
- Vice-Chairman - E. G. Paré, Washington State University
- Secretary - E. W. Knoblock, Oakland Community College
- Senior Council Member - J. H. Porsch, Purdue University

COMMITTEES ESTABLISHED ACCORDING TO BY-LAWS

EXECUTIVE

- E. W. Jacunski, University of Florida, Chairman
- E. G. Paré, Washington State University, Vice-Chairman
- E. W. Knoblock, Oakland Community College, Secretary (1 year)
- J. H. Porsch, Purdue University, Senior Council Member
- C. W. Chance, University of Texas, Director (5 years)
- R. E. Worsencroft, University of Wisconsin, Director (2 years)
- M. W. Almfeldt, Iowa State University, Director (3 years)
- P. H. Hill, Tufts University, Director & Treasurer (4 years)
- J. N. Arnold, Purdue University, Director (1 year)
- W. B. Rogers, USMA, Division Editor (1 year)
- E. D. Black, General Motors Institute, Editor (1 year)
- K. E. Botkin, Purdue University, Advertising Manager (3 years)
- J. H. Earle, Texas A & M University, Circulation Manager & Treasurer (2 years)

PUBLISHING BOARD, JOURNAL OF ENGINEERING GRAPHICS

- E. D. Black, General Motors Institute (1 year)
- E. E. Sautter, General Motors Institute
- W. B. Rogers, U. S. Military Academy

ELECTIONS

- E. G. Paré, Washington State University, Chairman
- J. T. Kimbrell, Washington State University
- R. O. Byers, University of Idaho

Continued on Page 18

The basics of engineering drawing in light of present-day requirements

FUNDAMENTALS OF ENGINEERING DRAWING, Fifth Edition, 1965

by Warren J. Luzadder, **Purdue University**. Requiring no prerequisites, the Fifth Edition of this widely-adopted text gives a still more comprehensive coverage of the field, with particular emphasis on basic fundamentals. It contains over 1,200 illustrations, many with surface shading, and incorporates ASA and SAE standards and practices. The following chapters have been written or revised: Tool Design and Tool Drawing; Electronic Drawings, Shop Processes and Shop Terms; Multiview Drawing and Conventional Practices; Auxiliary Views and Basic Descriptive Geometry. Includes a 48-page appendix. 1965, 752 pp., \$10.50

PROBLEMS IN ENGINEERING DRAWING, Fifth Edition, 1966

by Warren J. Luzadder, J. N. Arnold, both at **Purdue University**, and F. H. Thompson. This new revision of laboratory practice material includes a set of 72 standard problems, presented as partially drawn layouts for your students to complete. Printed on loose sheets of 8½" x 11" manila-type drafting paper and tracing vellum, they allow students to cover the maximum amount of subject matter with a limited time. 1966 72 sheets, \$4.25

WORKSHEETS IN GRAPHIC SCIENCE AND CREATIVE DESIGN

by Morris D. Silberberg and Sandor T. Halasz, both of **The City College of the City University of New York**. This vinyl care-bound kit provides sufficient material for a full course in graphic science or engineering drawing. The instructor may select plates best fitting his program and objectives, and omit others, without endangering the continuity of presentation. The 95 worksheets are keyed to seven of the most widely-used texts in the field. Unified treatment of orthographic and isometric reading and sketching exercises enables the student to view the problem of space visualization as a whole and not as a group of isolated spots. 1965, 8½" x 11", vinyl case: 11½" x 16¾", \$7.75

BASIC GRAPHICS

by Warren J. Luzadder, **Purdue University**. The fundamentals essential to graphical solutions and communications. Each basic concept is discussed clearly and in detail, anticipating difficulties commonly encountered by students. Emphasis is on freehand drafting and pictorial sketching and there are over 1,100 illustrations. All material is in full agreement with the ASA standards. 1962, 715 pp., 7½" x 10", \$10.50

(Prices shown are for student use.)

For approval copies, write: Box 903

PRENTICE-HALL, Englewood Cliffs, N.J. 07632

H. M. Curran, Department of M. E., the Catholic University of America, Washington D.C. 20017 has developed a set of Area Moment Scales for Graphical Evaluation of Integrals. These scales are printed on dimensionally stable base material and can be obtained from Professor Curran at the above address. He informed us the approximate cost will be \$1.50 to \$2.00.



Ford Sponsors Faculty Residences in Engineering Practice

The Ford Foundation has announced that a program enabling young engineering professors to gain high-level experience in industry through one-year residencies will be expanded and continued through 1970.

The program began in 1964 on a three-year trial basis with \$300,000 in Foundation funds. It has already proved sufficiently successful to warrant expansion, said Carl W. Borgmann, director of the Foundation's Science and Engineering program. An additional \$940,000 has been provided for the new phase.

About 150 faculty members will be awarded residencies in the second period, beginning in June 1967, for "clinical" practice in industry and in government installations engaged in nonmilitary engineering work. A total of some sixty residencies were provided for in the first three-year period.

The program is designed to counterbalance a growing tendency toward abstractness in technological education. "There was a time when engineering education lacked sufficient emphasis on mathematics and the physical sciences; now the need is to learn how to apply the new sophistication," Mr. Borgmann said.

"Newly graduated engineers (and their teachers) are better equipped than ever in the sciences and mathematics and for research. But they are often too far removed from engineering practice that is affected by considerations of cost, design, competition, employee relations, and marketability -- especially in that sector of industry dealing with civilian goods and services."

Under the program, each resident serves a year to fifteen months as a paid employee in a company working under a senior engineer who serves as a "preceptor." The preceptor assigns the resident to essential company tasks that also strengthen the faculty member's professional growth by bringing him into intimate touch with the execution of projects and with decision-making analyses leading to final engineering judgments.

Participants are nominated by deans of engineering schools, screened by a committee of advisors from industry, and selected by the Foundation when a suitable position is found in industry. The companies pay the residents' salaries and the Foundation pays for travel to interviews, moving costs of the residents and their families, and other administrative costs of the program. Residents must be American or Canadian engineering faculty members under the age of forty who hold the Ph.D. or equivalent degree and have taught at least one year after receiving the doctorate.



MEMBERSHIP COMMITTEE REPORT

The Membership Committee of the Division of Engineering Graphics met in Pullman, Washington on June 22, 1966 to discuss activities that would stimulate memberships in the ASEE. Those in attendance were: Chance, McDonald, Oppenheimer, Rogers, Knoblock, and Earle.

Many suggestions were offered that would be helpful. The major conclusions reached by the committee are outlined below:

1. It was generally agreed that membership recruitment should be confined to junior colleges and technical institutes rather than high schools.
2. The Journal of Engineering Graphics appears to be the best means of introducing prospective members who are uninformed to the Division's activities. Therefore, it is believed that a subscriber to the Journal would be a better prospect for membership into the ASEE than a nonsubscriber. Consequently, the Membership Committee recognizes a dual role of recruiting subscribers as well as members.
3. Publications that serve the junior college and technical institute teachers should be contacted for possible news items that would stimulate interest in the Division.
4. Mailing lists of prospective members will be sought from the available sources as a means of contacting individuals by direct mail.
5. A proposal will be made to the Executive Committee of the Division in March which outlines a plan for developing and distributing a brochure that describes the Journal and the Division. This will be used to contact prospective members.

The meeting adjourned with the understanding that all were willing to actively participate as members of the committee. All agreed to give thought as to how the committee could function more effectively during the coming year.

Respectfully submitted, James H. Earle
 Continued on Page 46 Chairman,
 Membership Committee

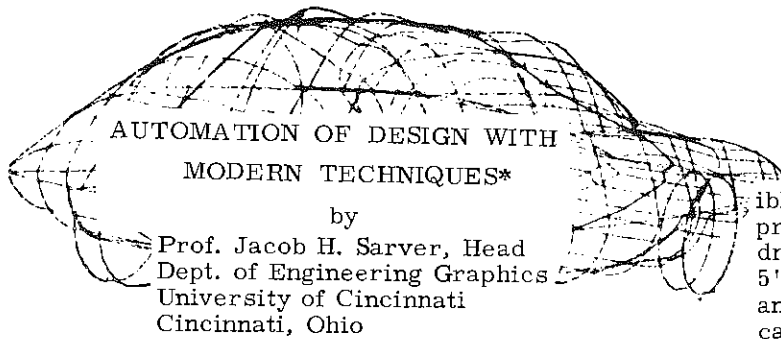

4. Computer Graphics is a technique that takes input coordinates or data and through a built-in computer logic and subroutines transforms this information into the required output.

It is apparent that the work of the skilled designer continues to be as much in demand, if not more so, than ever before because of our rapidly expanding technology. It has been stated by people knowledgeable in the field that the technology developed in the last ten years equals that developed in the previous fifty years and that our total technology will double in the next ten years.

As a result of this demand, the engineering designer has developed and is presently developing new ways and means in meeting this challenge. Some of the more important developments are (1) automated drafting with computer graphics, (2) use of scale models, (3) photodrawings, (4) simplified drawings, and (5) a wide variety of minor drawing aids such as templates, curves, adhesive lettering and symbols.

AUTOMATED DRAWING. The advent of the computer and numerically controlled, high-precision drafting tables such as those produced by the Gerber Scientific Instrument Co., Faul/Coradi, Visual Inspection Products, Universal Drafting Machine Corp., and others; with the assistance of T.V., light scanning devices, CRT, digital and analog computers, and now lasers, have done much to lighten the load of the designer and enable him to bring his ideas and dreams sooner to actuality than was possible a few years ago.

Associated with this new technology is the need to define certain terms which will be used.

1. Drawing is a graphic method of associating the geometric form of a part or component with the numbers which specify the magnitude and relationship of its elements.
2. Master dimensioning is, basically, measuring the distance of all required points on an object from one point of origin.
3. Numerical control is a manufacturing technique which automatically manipulates the movement of plotting arms, machine tool slides, or tables through certain specified distances and in the desired directions.

*Presented at Michigan State University, October 22, 1965, Mid-Year Meeting of the Engineering Graphics Division of ASEE

The use of this equipment provides a reversible path for the presentation of ideas, or for the production of the finished product. An orthographic drawing may be placed on the table -- as large as 5' x 20' -- of the automated drafting equipment, and through a scanning device -- light beam, T.V. camera, or laser --, coordinate information is fed to the computer. Then by means of computer graphics this data may be used to produce a perspective drawing, a scale or full-size model, or shown on the CRT (cathode ray tube) screen where changes may be made by light-pen or programmed intervention. The process may then be reversed to produce new drawings accurate to ± 0.001 of an inch. Designs have been produced by this method in about 30 minutes that normally required as much as 3 months for completion. See Figure 1.

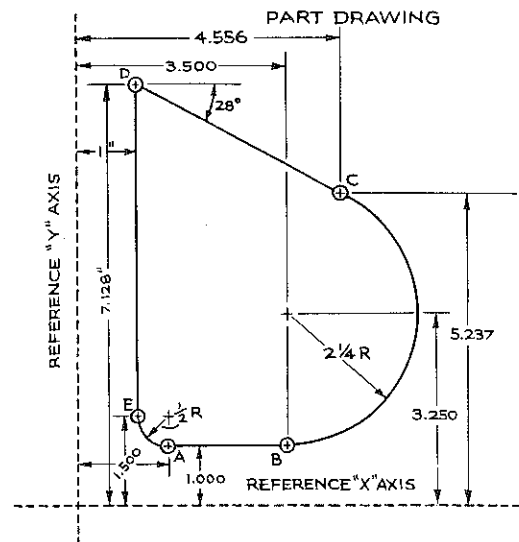

Figure 1. Sample Part Drawing.

Interest in this new technology of automated design and computer graphics has its major impetus in the automotive field, but other industries are also doing experimental work in this area. A noted architect is experimenting with its use in the design of apartment houses, office complexes and ideal communities; A major bridge builder has shown interest in automated drafting equipment; The Chemical Processing Industry (CPI) has made use of the computer and a display mechanism such as CRT or numerically controlled drafting machines to reduce considerably the time and toil necessary in making piping drawings. This type of drawings account for 30-50 per cent of the total engineering drafting and design effort of a plant involved primarily in the handling of fluids. The designer prepares a freehand isometric sketch based on information from a scale model and from this he prepares data to be fed to the computer. Another approach is for the designer

working with flow diagrams, and plot plans to place on punch cards the design conditions and other essential data. The computer then computes and generates a drawing complete with dimensions.

The electronic designer is a combination of computers, light-scanning or laser-scanning measurement techniques, with numerically controlled drafting machines or display mechanism (CRT). It would seem conceivable that automation and new scientific developments would eventually eliminate the need for drawings in many areas. Such is not the case, as numerical control simply introduces a new type of drawing with a consequent change in information presented thereon. Here lies a need for the establishment of new drawing standards for numerical control. As was stated in the May, 1965 issue of Graphic Science, "the numerical-control tape communicates only with the machine, while the drawing communicates with everybody." If anything, numerical control adds another person who needs a drawing -- the programmer.

SCALE MODELS. Scale models are another design aid for the engineer, particularly in CPI. However, the design group must prepare piping sketches, drawings in flow chart style of main piping runs, and orientation drawings of equipment items before the modeling group can begin installation of piping and electrical lines on the model. At the Procter & Gamble Co. -- where one of my staff, Professor Gurbach, was employed this summer in the modeling shop -- the following drawings are used in building a model of a plant containing considerable piping.

Building Drawings - Showing structural and architectural details.

Process and Equipment Flow Chart - A schematic, usually freehand but may be made with instruments, showing general routing of pipe between major pieces of equipment and proper sequence for locating valves and instruments in the lines. It is prepared by the engineering staff in charge of various phases of the project and is the official document used in installing piping in the model.

On large projects, separate sets of flow charts are made for individual piping systems in the plant, such as steam, process air, instrument air, process water, etc. in addition to the regular more comprehensive set.

Detail Drawings - These are drawings of non-standard equipment such as tanks, bins, etc., and are made by the company's engineering department or by the supplier of the equipment.

Standard Drawings - Such drawings or catalog sheets of standard items, such as may be required of pumps, valves, instruments, etc. These are usually supplied by the manufacturer of these items.

A model makes it possible to see an unlimited number of views of the planned project and thus eliminates the need for space perception of those not accustomed to thinking spatially. Hence,

agreement among the various groups involved is hastened. A model is of greatest value when the complexity of the process or object warrants their construction. As most of you know, it also has high value as a teaching aid.

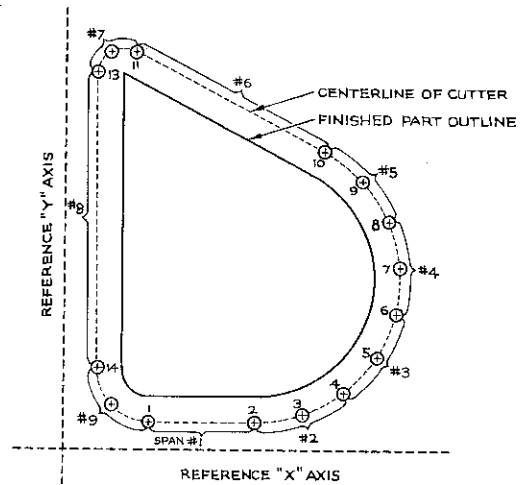

Figure 2. Sample Part Numerical Drawing.

Some CPI's feel that models are too expensive and that the job can be done equally well by three-dimensional drafting techniques, essentially those using isometrics.

PHOTODRAWINGS. Photodrawing techniques are not widely used but are combined with model-making in an attempt to reduce engineering design man-hours. Special photographic techniques are now under experimentation and study for producing complete and accurate drawings from the model. Photos of the model are taken with a long focal-length lens camera and copies are then distributed to the many interested groups such as designers, isometricians, material take-off men, etc., rather than shipping the model around for their perusal. It would seem that the use of a television camera could be used here very conveniently for transmitting pictures of model to interested in-plant groups, or possibly over greater distances.

SIMPLIFIED DRAWINGS. Much work has been done in the area of simplified drafting in recent years to eliminate unnecessary detail and views. However, its greatest usage has been for in-plant production rather than with drawings which must be sent to sub-contractors where there may be a misunderstanding of these concepts. Drawings which are now being prepared for use in programming for numerically controlled machines could be placed in this category.

INEXPENSIVE DRAWING AIDS. Finally, all types of devices, which are relatively inexpensive compared to numerical controlled drafting machines and scale models, are now available on the market to reduce tedious and time-consuming drawing details. Lettering templates, overlays of standard items or lettering with adhesive backing, tape overlays, and a variety of miscellaneous templates have gained wide acceptance in industry.

Continued on Page 58

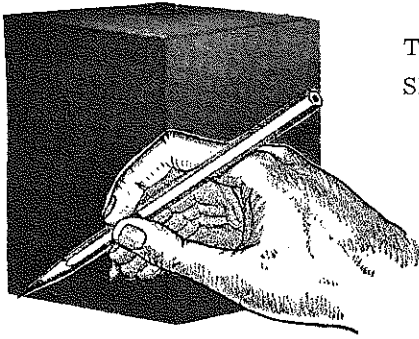

THE THOUGHT-MODEL METHOD OF TEACHING SPATIAL VISUALIZATION*

by

Professor A. S. Levens
University of California
Berkeley, California

In developing solutions to real engineering problems, the creative act of conceiving a physical means of achieving an objective is the first and most important step. Analysis of the possible solutions is the second step. Stated simply, synthesis in conception precedes the analysis required to refine the conception.

Identifying the creative person is not a simple matter. Many researchers have studied this problem for years. As yet, there exists no definitive tests for creativity.

Professor Harrison G. Gough, Professor of Psychology and Associate Director, Institute of Personality Assessment and Research, University of California, Berkeley, states in his paper, "Identifying the Creative Man," that the creative personality is intuitive and empathic, perceptually "open," i.e., not judgmental, aesthetically sensitive, emotionally and socially sensitive, and a complex personality. He concludes that:

"Testing for creativity is not the same thing as testing for intelligence or school achievement, and in fact tests of aptitude and achievement have proved to be of little or no use in identifying creative talent. There is a pretty obvious implication here for any selection program which seeks to find and to encourage creative potentiality. But although we cannot use these older and well-established tests directly, we can apply methodological skills gained in their construction to the building of tests which can identify creativity. Our hope lies with the future, but, I would add, a realizable future. We can now specify some of the aspects of personality relevant to creative work, and certain tests and scales within those categories already possess a limited validity. Complete validity is an impossibility, but we are moving rapidly toward a level of practical utility and accuracy in this significant domain of evaluation."

Professor Donald W. MacKinnon, Director, Institute of Personality Assessment and Research, University of California, Berkeley, in his paper, "Fostering Creativity in Students of Engineering," says:

*Presented at the A.S.E.E. meeting June, 1965 at Chicago, Illinois.

"We have no certain knowledge as to how to foster more effectively the potential creativity of engineering students. This is not to say however, that we know nothing about the creative process and creative persons. Recent investigations, like those in the Institute of Personality Assessment and Research on the Berkeley campus of the University of California, have shed considerable light upon the nature of creativity and the distinguishing characteristics of highly creative persons. But to make inferences from these findings as to how to identify creative potential in engineering students and how best to develop their creativity, is a precarious undertaking.

"The difficulties are several. Most of the subjects in our investigations have been mature persons in a number of fields of endeavor: engineering and scientific research in industry, mathematics, architecture, writing, etc. Whether or not or to what extent we can generalize from our findings with mature, creative, productive individuals to students in schools and colleges of engineering, I do not know.

* * *

"What to me is most strongly suggested by our findings is that we should seek to develop in students a capacity for intuitive perception and intuitive thinking, immediate concern for implications, and meanings, and significances and possibilities beyond that which is presented to the senses. This is not to suggest a slighting of facts, for there is a great wealth of information which every educated person must possess. Without a richness of experience, which includes a considerable body of fact, and especially so in engineering, intuitions may be original but are not likely to be very creative. But I would urge that in our instruction and in our training we never present a fact for its own sake, and that in our testing of our students' knowledge we shun questions which require no more than identification of facts and formulas. I am convinced that we can measure information which students have learned more reliably, more validly and more economically by objective tests than by essay examinations. But it remains true, I believe, that a student's preparation for

and actual writing of an examination which requires dealing with problems forces him to exercise his intuitive perception.

* * *

"More specifically I would suggest that no course or seminar deserves a place in a college curriculum unless it requires of the student the solution of some problem -- a research project, a term paper, etc. The requirement, stated in only the most general fashion, permits the student to determine what specifically his own problem will be. Thus he chooses, he sets the problem, and having done so, he might well be left to solve it in his own way. Thus we would provide the student with what I believe to be one of the necessary conditions for creative achievement; the undertaking of the solution of a problem where the degree of difficulty and frustration is great and the drive toward accomplishment is persistently strong."

In view of the above statements, I believe that the inclusion of conceptual design projects -- the open-ended types -- in our graphics courses is a most significant step forward.

Engineering as a profession is concerned primarily with design, which in the broadest sense includes circuits, machines, structures, processes, and combinations of these components into systems and plants.

Surely the professional engineer must be capable of predicting the performance and cost of the components, systems, and plants to meet specific requirements.

Designing is a conceptual process which is done largely in the mind, and the making of sketches is a recording process, a reliable memory system which the engineer uses for self-communication -- talking to himself -- to help him "think-through" the various aspects of his project. Graphics is an integral part of the conceptual phase because, more often than not, the making of a simple sketch to express a design conception does of itself suggest further items of a conceptual nature.

Engineers who have developed the ability to form a visual image of geometrical and physical configurations and to "think graphically" have a tremendous advantage in creating a physical means of achieving a technological objective.

How can we help our young engineering students to develop effective powers of visualization and "imagineering"?

Exciting and stimulating teaching of the fundamentals of orthogonal projection and their application to a variety of space problems affords an excellent means to develop in this respect.

Over the years many experiments in visualization have been tried. Professor Mary Blade of the Cooper Union did a fine job in her paper, which

was published in the Journal of Engineering Drawing, November 1949.

Rather than debate the pros and cons of the findings by investigators in the field of psychology and of engineering, I believe that there is considerable value in the thought model method as a means for developing power in visualization.

Before describing the approach used at the University of California at Berkeley I should point out that the teaching technique used in our experiment is, most likely, one of several that could produce good results.

Our method, called the "Thought Model" method, consists of tracing and describing related points, lines, planes and surfaces, in the air, by use of the hands. The construction of imaginary figures is accomplished by verbal descriptions. The orthogonal representation of these figures is made on the blackboard. The two-dimensional representation, however, is made only after the student has the experience of "seeing" and "manipulating" the visualized three dimensional configuration. In this way it is possible to create geometric space relations which are so fully visualized that the students can come forward and add items, describe elements, analyze and solve problems -- employing the imaginary figure.

Students with high aptitude for comprehension of spatial relationships undoubtedly accomplish this automatically regardless of the method used to teach engineering graphics. However, when the thought model method is used by the instructor at the beginning of the course, it provides a shared experience in visualizing an imaginary figure for all members of the class. The thought model greatly facilitates communication among the students who can now discuss imaginary figures with confidence.

On the other hand, students of descriptive geometry trained conventionally often spend a great deal of time working with two dimensional representations or projections until they finally "see" what the problem is. "Seeing" of course, results in the familiar "Aha!" experience described by psychologists. In one sense the thought model method can be described as a means of providing the beginning student with the "Aha!" experience at the very outset of his engineering education -- providing it in such a natural manner that the student never imagines that engineering graphics could consist of anything more difficult. With confidence in his ability to visualize a problem the student is then prepared to advance to ever more complex problems requiring visualization and employ graphic techniques to problems not ordinarily thought to be susceptible to such methods.

I believe that widespread use of the thought model method would significantly improve the synthesis and analysis abilities of both engineering and science students and would probably have important applications in other disciplines as well. I won't burden the reader with the details of the

Continued on Page 30

FUNDAMENTAL THEOREMS OF THE GEOMETRY OF FOUR DIMENSIONS

by

Dr. Luisa Bonfiglioli
Post-Doctoral Research Fellow
Technion - Israel Institute of Technology

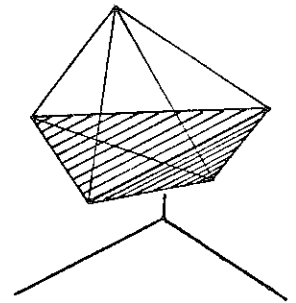
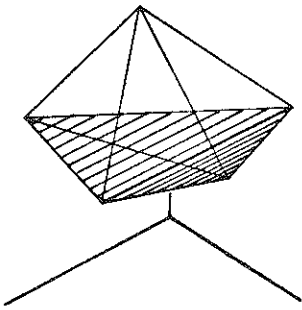

The geometry of four dimensions is not a subject taught in engineering schools in spite its connection with several engineering problems. Only the main fundamental concepts will be explained in the simplest possible manner in this article.

Suppose that at the corner of Nassau and Olden Streets one is asked, "Where is the main Library?" The response will be: go ahead along Nassau Street for some hundred feet. (Figure 1).

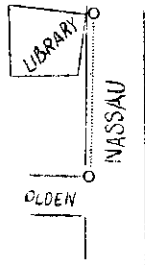

Figure No. 1

But if the inquiry is: (Figure 2) "Where is the McCarter theatre?" The information required will be: go ahead along Nassau Street to the corner with University Street and then go to the left for some hundred feet.

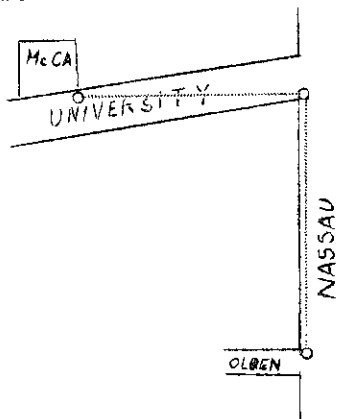

Figure No. 2

But if (Figure 3) a more specific question is asked: "Where is the McCarter theatre and the manager's office in it?" To the second information must be added: when you arrive at the building go upstairs to the second floor. All this proves that there is information that requires only one indication, others requiring two indications and others - three indications. It is worthwhile to notice that in the first case we had two fundamental points: the starting point and final point; in the second case three fundamental points: starting point, intermediate point and final point; they do not lie on a straight line; in the third case, four fundamental points; starting point, intermediate point, door of the elevator, final point; they do not lie on a plane.

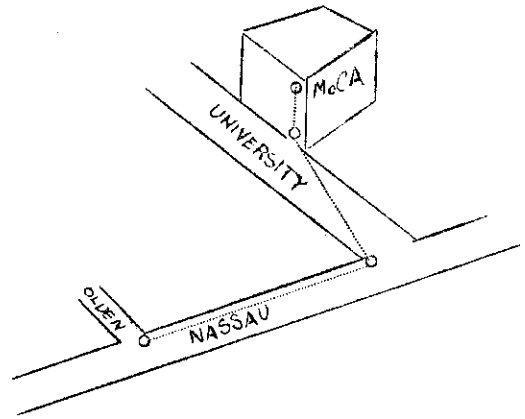

Figure No. 3

If we translate these examples in an abstract language we can say that there are entities that depend on one, two, or three elements. Their geometrical representation is given by: a straight line, a plane, a space. The line is determined by two points, (Figure 4) a plane is determined by three non-collinear points (Figure 5); a space is determined by four non-coplanar points. (Figure 6).

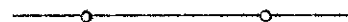

Figure No. 4

(Lecture Presented to a Class in Engineering Graphics, School of Engineering and Applied Science, Princeton University) February 2, 1966

A plane contains infinite lines and each line has all the properties of a single isolated line but because there are several lines on the plane, this

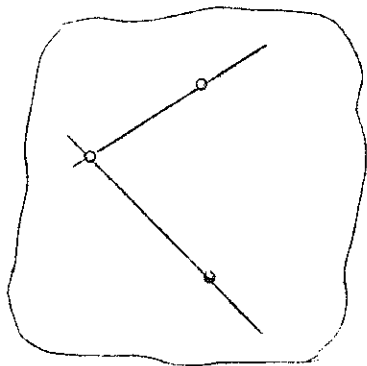

Figure No. 5

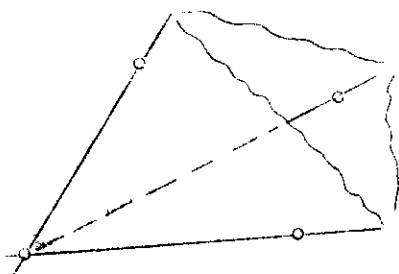

Figure No. 6

plane has its own particular properties that are not due to a single line. So a space contains infinite lines and planes; each one of them has all the properties that are specific to it but the space has its own new properties.

In order to generalize the geometry we say that the lines and planes are also spaces: the line is a space of one dimension D_1 ; the plane - of two dimensions D_2 ; the space of three dimensions D_3 . The point is considered as a space of zero dimension D_0 .

But now suppose the same request for directions is made from the same starting point not to a mortal but . . . to God. Because He knows the instant in which He has created the universe to my information He certainly will add another indication: the time that has elapsed from that moment of creation.

That means the information is composed of four indications and this leads to five points not belonging to the normal space D_3 because the element time is not a thing that can be measured by means of the first three distances.

According to this answer we deduce that our normal space is immersed into an amplified new space called space of four dimensions D_4 .

Indeed this is the space that is used in physics but because the physicists are men and they cannot refer to the precise moment of the creation

of the world they refer the time to a certain fictitious origin and from this comes the name "relativity" given to this branch of physics.

But this is not the only way for creating a space of four dimensions. For example: a team of doctors studies the causes of a certain illness. They find that it depends on:

- a. the age of the inhabitants
- b. the climate
- c. the quantity of iodine dissolved into the water
- d. the quantity of a certain food eaten by the inhabitants.

This is a problem depending on four variables that can be related to a space D_4 of four dimensions that are not distances and time.

Hence we can state: each problem depending on four variables must be related to a space of four dimensions.

But then the first obvious question that comes to our mind is: in what manner can we handle this kind of problem?

The simplest thing is to denote by x, y, z, t the variables of the problem and to solve it by means of calculations without giving to it a concrete representation.

This solution was made by several mathematicians and this topic is discussed in a very short chapter in the book "Higher Geometry" by Frederick S. Woods.

This could be the end of the story but really it is the beginning because one of the peculiarities of the human being: is the need of representing all events that happen in their world.

This representation can be made in several ways: the pictorial way is generally chosen as its best and clearest expression, because in this regard poor sight is better than good hearing.

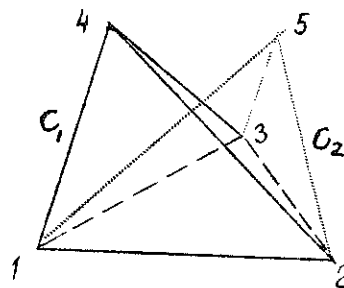

Figure No. 7

And because our imagination is very, very limited these pictures have to be similar to things to

Continued on Page 32

by

L. M. Weiner

Illinois Teachers College Chicago-North

A nomogram is a graphical computational aid for evaluating one of the variables in an expression of the form $F(x, y, z, \dots, w) = 0$ given the values of the others. Nomograms have long been used by engineers and physicists to facilitate their computations.

Another device in common use as an aid in performing various computations is the slide rule. In examining the relative merits of these two devices, one finds that the slide rule has several advantages over the nomogram; namely,

1. The slide rule generally gives more accurate readings.
2. The slide rule is easier and quicker to use in that no straight edge is required
3. There is no need to mark up a slide rule as is usually done in the case of a nomogram so that it may be used over and over again indefinitely.

In view of these advantages it would seem desirable to have available methods for constructing slide rules which would do the same computations as certain nomograms, and the present paper provides several such constructions.

In a three-parallel scale chart such as illustrated in Figure 1, three variables $x, y,$ and z are laid off at distances $f(x), g(y), h(z)$ along each of three vertical scales starting at the bottom, and the collinearity of the three points $x, y,$ and z means that $F(x, y, z) = 0$ or as is seen by Figure 1 that

$$\frac{g(y) - f(x)}{h(z) - f(x)} = \frac{a}{b}$$

This is reducible to

$$\log f(x) + \log \left[\frac{b - h(y)}{g(y)} \right] = \log [a - h(z)]$$

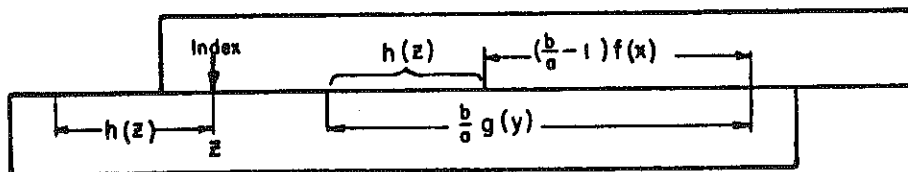

Figure 3

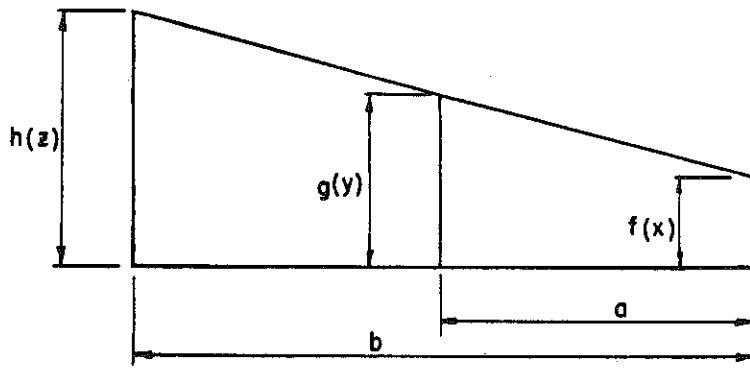

Figure 1

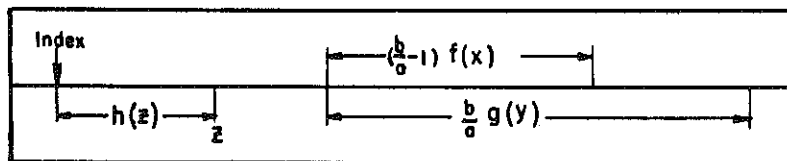

Figure 2

The resulting slide rule is shown in Figures 7 and 8.

The more complex nomograms would no doubt require more elaborate procedures to transpose them to slide rules; however, the same principles could probably be applied in most cases to achieve a slide rule which would do the same job easier, quicker, and more accurately.

References

1. Ford, L. R., Some Slide Rules, *The American Mathematical Monthly*, V. 52, 1945, p. 328-334.
2. Weiner, L. M., A Slide Rule For Relationships Involving Three Variables, *School Science and Mathematics*, February, 1966, p. 138-140.

Continued on Page 44

Officers and Committees, Cont.

NOMINATIONS

B. L. Wellman, Worcester Polytechnic Institute
M. McNeary, University of Maine
Irwin Wladaver, New York University
A. P. McDonald, Rice University
A. L. Hoag, University of Washington

POLICY

I. L. Hill, Illinois Institute of Technology,
Chairman
J. N. Arnold, Purdue University
R. H. Hammond, U. S. Military Academy
R. T. Northrup, Sr., Wayne State University
M. F. Blade, The Cooper Union

SPECIAL AWARDS

J. H. Porsch, Purdue University
B. L. Wellman, Worcester Polytechnic Institute,
Chairman
R. H. Hammond, U. S. Military Academy

AWARDS

A. L. Hoag, University of Washington, Chairman
D. P. Adams, Massachusetts Institute of
Technology
F. K. Brown, Northeastern University
D. M. Case, Indiana Institute of Technology
G. J. Cowell, University of South Florida
J. B. Dent, Virginia Polytechnic Institute
E. M. Griswold, The Cooper Union
K. R. Gulden, Rensselaer Polytechnic Institute
I. L. Hill, Illinois Institute of Technology
R. O. Loving, Illinois Institute of Technology
A. S. Palmerlee, University of Kansas
J. S. Rising, Iowa State University
H. F. Rogers, Ohio University

BIBLIOGRAPHY

F. H. Smith, University of Michigan, Chairman
E. D. Black, General Motors Institute
W. Felbarth, University of Detroit
C. B. Pfeffer, Wichita State University
T. C. Smith, University of Nebraska
I. Wladaver, New York University

DISPLAYS

J. R. Barylski, S. E. Massachusetts Technological
Institute, Chairman
C. C. Cooley, University of Detroit
W. A. Earl, Alfred University
H. T. Jenkins, University of Michigan
J. T. Kimbrell, Washington State University
B. L. Kreimer, Northeastern University

EDUCATIONAL RELATION

K. E. Kroner, University of Massachusetts,
Chairman
S. C. Allen, Michigan Technological University
S. E. Bakken, North Dakota State University

L. N. Blair, University of Illinois, Chicago Circle
R. J. Cambre, University of Southwestern
Louisiana
L. C. Christianson, University of Missouri at
Rolla
W. M. Christman, University of Wisconsin
(Milwaukee)
R. M. Coleman, Texas Western College
H. M. Faulkner, Onondaga Community College
A. S. Gaskell, University of Missouri
G. C. Grubb, Arlington State College
C. W. Keith, Kent State University
R. S. Lang, Northeastern University
R. E. Lewis, Duke University
C. P. Marion, Jr., University of Miami
J. W. Meyer, Chicago City Junior College
S. P. Owen, Rutgers - The State University
I. W. Roark, University of Tulsa
K. A. Snoblin, Lawrence Institute of Technology
R. W. Waymack, Modesto Junior College

GOALS OF ENGINEERING EDUCATION

J. S. Dobrovoly, University of Illinois, Chairman
C. J. Baer, University of Kansas
M. F. Blade, the Cooper Union
C. P. Buck, Syracuse University
S. A. Coons, Massachusetts Institute of Technology
R. H. Hammond, U. S. Military Academy
P. H. Hill, Tufts University
H. T. Jenkins, University of Michigan
E. V. Mochel, University of Virginia
P. M. Reinhard, University of Detroit
S. M. Slaby, Princeton University
E. R. Weidhaas, The Pennsylvania State
University

INDUSTRIAL RELATIONS

R. D. Springer, University of Minnesota,
Chairman
J. E. Bennett, University of Alabama
M. Bezbatchenko, University of Akron
F. J. Burns, Newark College of Engineering
R. J. Christenson, General Motors Institute
J. T. Dygdon, Illinois Institute of Technology
H. H. Gernandt, Jet Propulsion Laboratories
M. E. Hamilton, New Mexico State University
A. E. Messenheimer, Kansas State University
G. E. Pankratz, University of Toledo
T. A. Pickard, Westinghouse Electric Corporation
R. W. Reynolds, California State Polytechnic
College
F. H. Thompson, Allison Division of General
Motors

INTER-DISCIPLINARY

S. M. Slaby, Princeton University
M. F. Blade, The Cooper Union
C. F. S. Lindgren, Design Engineering, Pittsburgh
H. L. Calendar, Rutgers - The State University,
New Brunswick

LONG RANGE PLANNING COMMITTEE

J. N. Arnold, Purdue University, Chairman
E. D. Black, General Motors Institute

Continued on page 28

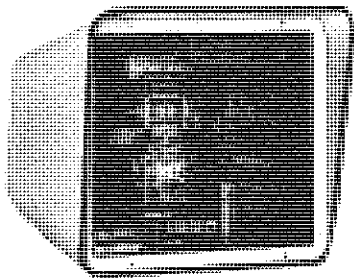

THE SUMMER DRAFTING INSTITUTE AT TEXAS A&M UNIVERSITY

by

Charles R. Cozzens and Gary Johnson
West Texas State University

Abstract

The purpose of this paper is to report briefly on the drafting institute which was held on the campus at Texas A&M University during the summer session of 1965. The institute was jointly sponsored by the Engineering Extension Service and the Engineering Graphics Department at Texas A&M University.

The course was designed so students might learn or improve the skills which are necessary for employment as draftsmen. The program consisted of three weeks of basic mechanical drawing, three weeks of descriptive geometry, two weeks of steel detailing, two weeks of concrete detailing, and one week of aluminum detailing. A term project was completed during the final week of classes.

Three hundred sixty hours of class work were provided for the twenty-five students who completed the course, and a follow-up study is being planned to determine the overall effectiveness of the institute.

A vocational drafting institute was held on the campus of Texas A&M University during the summer of 1965. It was jointly sponsored by the Engineering Extension Service and the Engineering Graphics Department at Texas A&M and represented the planning and research completed by several members of the co-sponsoring agencies. The program offered the thirty beginning students an opportunity to learn or improve upon skills which could be used to fill existing job vacancies in industry. Such a program had been considered for some time; and after final approval for the institute was granted, a committee was formed to determine, among other things, which drafting specialty was most in demand in Texas.

The Industrial Drafting Training Committee, composed of L. E. Stark (Chairman), S. M. Cleland, and P. M. Mason, all of the Engineering Graphics Department, distributed questionnaires to 184 industrial firms throughout Texas. The eighty-one forms which were returned constituted a 44 per cent response and showed that the need for structural draftsmen far exceeded that for any other specialty. With this particular bit of information to lend guidance, selected members of the co-sponsoring agencies started preliminary planning for the institute which was to start June 7, 1965.

One of the first actions taken was to select teachers for the program. After reviewing the qualifications of several prospects, three members of the Engineering Graphics staff were nominated to fill the positions. Based upon their academic preparation and practical industrial experience, N. B. Bardell, C. R. Cozzens, and M. P. Guerard were chosen as instructors. Their qualifications were presented to and approved by the Technical

Education Division of the Texas Education Agency in Austin, Texas.

Tentative plans regarding course content were outlined, but final decision was reserved until practicing structural engineers could be consulted. To aid in determining those phases of structural drawing which would be most appropriate for the course, four members of the Engineering Graphics Department visited such consulting engineering firms as Bovay Engineers, Inc. and Brown and Root, Inc. These visits proved to be a wise investment of time and effort and largely confirmed the validity of the preliminary planning.

The final outline for the course provided for 360 hours of class room lecture and practice. This total was divided into two 180 hour sessions lasting six weeks each. During the first six weeks the students were permitted to complete the same general course work required of all beginning engineering students. These offerings included geometric construction, orthographic projection, pictorials, auxiliary views, dimensioning, vector graphics and so on.

The second six weeks provided for study in three major units: steel detailing, concrete detailing, and aluminum structural design and detailing. These offerings required five weeks for completion; the sixth week was allotted for a term project. Figure 1 shows a listing of the general topics covered during the twelve weeks and gives the amount of time devoted to each.

The unit on steel detailing studied during the second six weeks required the students to detail simple square-framed beams, design framed beam connections to withstand given loads, calculate reactions and moments, design seated and skewed connections and detail columns. During this time the students made extensive use of the Manual of Steel Construction. This phase of the course provided the students with lucrative opportunities to gain broad practice in the use of the slide rule.

The unit on concrete allowed the students to study the placement of steel reinforcement bars and to draw and detail such concrete members as beams, girders, slabs, columns, and footings. The recommendations for detailing as outlined in the Manual of Standard Practice for Detailing Reinforced Concrete Structures were observed in the classroom.

The second six weeks provided for study in three major units: steel detailing; concrete de-

tailing, and aluminum structural design and detailing. These offerings required five weeks for completion; the sixth week was allotted for a term project. Figure 1 shows a listing of the general topics covered during the twelve weeks and gives the amount of time devoted to each.

The unit on steel detailing studied during the second six weeks required the students to detail simple square-framed beams, design framed beam connections to withstand given loads, calculate reactions and moments, design seated and skewed connections and detail columns. During this time the students made extensive use of the Manual of Steel Construction. This phase of the course provided the students with lucrative opportunities to gain broad practice in the use of the slide rule.

COURSE OUTLINE

Subject	Hours
Lettering	8
Use of the Drawing Instruments	4
Geometric Construction	4
Orthographic Projection	21
Sketching	12
Pictorials	9
Auxiliary Views.	20
Sections	9
Dimensioning	6
Shop Math.	21
Shop Processes	8
Working Drawings	12
Use of the Slide Rule	8
Point, Line, and Plane Relations	9
Vectors	20
Steel Beam Detailing	21
Structural Frame Connectors	21
Stiffened Seated Connections	6
Unstiffened Seated Connections	6
Steel Column Detailing	6
Concrete Beam Detailing	24
Concrete Column Detailing	18
Concrete Slab Detailing	18
Aluminum Structural Detailing	30
Term Project	30
Field Trips	9
TOTAL	360

THE GENERAL COURSE OUTLINE FOR THE SUMMER DRAFTING INSTITUTE

Figure 1

The unit on concrete allowed the students to study the placement of steel reinforcement bars and to draw and detail such concrete members as beams, girders, slabs, columns, and footings. The recommendations for detailing as outlined in the Manual of Standard Practice for Detailing Reinforced Concrete Structures were observed in the classroom.

The third major unit, that on aluminum, was perhaps the most technical of all. After the students had been introduced to beam design and

detailing and had become familiar with graphical truss analysis, they were asked to design and detail certain structural members to carry given tension and compression loads. It became necessary, then, to introduce such new ideas as cross-sectional areas, moments of inertia, radii of gyration, and slenderness ratios. Once again the students found their slide rules to be very handy tools. Reference material for this phase of the course was taken from the Alcoa Structural Handbook, a manual provided through the courtesy of the Aluminum Company of America.

During the final week of the course, the students drew details for a covered grandstand which might be built beside a tennis court to accommodate approximately four hundred spectators. The basic design of the roof truss, columns, slabs, seating arrangements, etc., was given, and the students drew details which could be used for the fabrication and erection of the structure.

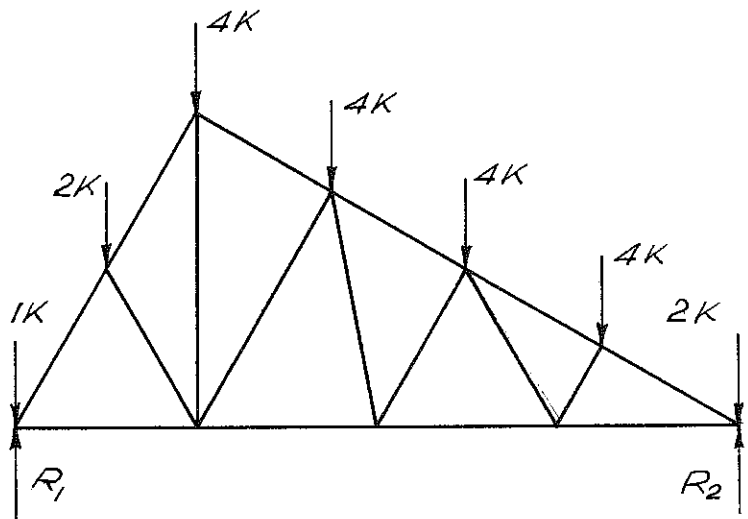

Classes were scheduled for six hours each day starting at 7:00 a.m. and continuing until 10:00 a.m. At 1:00 p.m. classes resumed and lasted until 4:00 p.m. Generally, the first hour of each session was used for a rather informal lecture and discussion of the topic to be considered. During this period a lesson assignment sheet was distributed to the students. This sheet told what topic was to be covered during that session and briefly stated the main objectives for the lesson. It outlined an assignment and told, among other things, when the assignment was to be returned for scoring. Generally, if an assignment was made during the morning session, it was required of the students by 1:00 p.m. Some exceptions were made, however, if the assignment was unusually lengthy. Figure 2 shows the general format for the lesson assignment sheets, and Figure 3 shows an assignment as it was completed by one of the students.

An estimated 60 per cent of all drawings were completed on tracing paper, and periodically the students were required to make reproductions of

Continued on Page 48

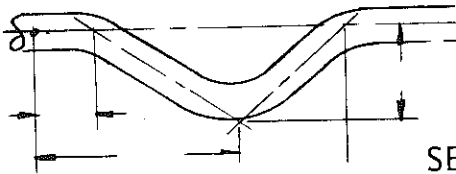

DESCRIPTIVE GEOMETRY A SELF-DEPENDENT SPATIAL SCIENCE

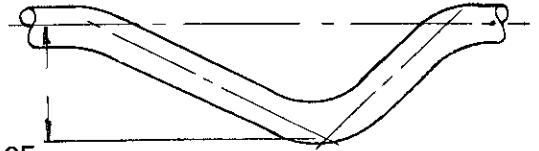

by

Thaddeus D. Pozniak
Canisius College of Buffalo, N. Y.

Let it be stated at the beginning of this article, that its purpose is to defend the position of descriptive geometry, which seemed to have suffered rather considerably, from a few definitely critical remarks, made by Prof. V. P. Borecky¹ in his interesting article "Peculiar Lines and Planes" -- in the February, 1966 issue of the Journal of Engineering Graphics, Vol. 30, No. 1.

The main part of Prof. Borecky's article, under the subtitle of "Projective Geometry, Axis of Homology," starts with the statement, (p. 20): "Projective Geometry is all geometry."

Today -- it is clear, that topology is logically basis to projective geometry.¹

Another important point, calling for some clarification, is the confusion of the affinity, collineation, and homology-lines, with the peculiar line.

Affinity, (collineation, homology) axes -- belong to projective geometry, they are ideas nearly 150 years old. The "peculiar line" belongs to descriptive geometry, and it is a five year-old idea.

The peculiar line was found independently of projective geometry. It was found by means of "peculiar points", the latter being purely descriptive geometry ideas (the piercing points of lines with planes containing the HF-folding line).

In other words the peculiar line was found within descriptive geometry, and by its own power alone.

One important point should be made positively clear:

This is not the only instance in mathematics that the same symbol, or the same line -- stands for two entirely different concepts.

The numeral "5" stands for number "five", or for the ordinal numeral "fifth." The same symbol standing for entirely different meanings, which must not be confused. Any confusion of the two, would be mathematically incorrect.

The graph of the equation $2x + 3y = 4$ is the straight line, and the graph of the function $y = \frac{4-2x}{3}$ is exactly the same straight line.

But it is wrong to say that the concept of the equation is the same as that one of the-function. Equating the two would be mathematically incorrect.

A great many similar examples could be cited for the illustration of the problem in question.

It is the meaning of the symbol that makes an idea, and not the symbol itself.

The same symbols and the same lines may represent entirely different ideas.

The affinity, (collineation, homology) lines were found by projective geometry methods, and they are projective geometry ideas.

The peculiar line was found by descriptive geometry method, and it is a descriptive geometry idea.

Though graphically they are the same line, they are not identical ideas.

To confuse the two concepts is geometrically incorrect.

Projective geometry and descriptive geometry are different branches of geometry. They coincide sometimes; they permeate to some degree (as does any other branch of mathematics,) but they are different. Descriptive geometry is a spatial geometry, whereas projective geometry is basically plane geometry in its concept.

There is another essential point for the support of the originality of the peculiar line as a descriptive geometry idea which must not be confused with the projective geometry concept of the affinity line.

The peculiar line, being by its origin and by its nature a descriptive geometry idea, gives rise to new, basic, descriptive geometry constructions which are unobtainable by projective geometry methods, and, which -- independently of their possible practical value, -- have their value in pure geometry.

For this reason alone, the peculiar line enhances the potentiality of the science of descriptive geometry. It proves that descriptive geometry is capable of uncovering new facts on its own.

In the light of the above remarks -- the hint "inventing old facts" (p. 20) cannot be referred to the peculiar line, which in reality is a new fact, which has been covered, for a long time by an old fact, in this case, -- by the affinity line.

Also, the dismissal of the hundred year old direct method (American 3-rd angle projection) as "adequate" (p. 54) seems to be at least a controversial opinion.

Much, of course, could be said on this subject from both theoretical and practical standpoints.

From the geometrical standpoint, both the first angle projection and the third angle projection are equally adequate.

The point is that the whole three-dimensional space be adequately accessible and operable.

As far as the theoretical and also a practical aspect of the third angle projection is concerned, successive auxiliary views would be rather strongly in favor of the direct method. One thing is sure -- the real answer to that serious problem can be reached only through an extensive, objective research -- and not by arbitrary judgment alone.

It is generally agreed among the descriptive geometry and engineering teachers -- and it has been recently confirmed by an extensive nationwide study² by groups of experts -- that (p. 8) "The importance and necessity of solid background in the theory of descriptive geometry be recognized." It was affirmed in the study that "the ability to visualize . . . to form a mental image . . . particularly in the area of spatial relations" is the "most basic talent" an engineer should develop "with the help of descriptive geometry."

In other words, the spatial character and the irreplaceable role of the science of descriptive geometry in teaching has been authoritatively reaffirmed.

There was no specific recommendation for abandoning the third angle projection nor for introducing the elements of projective geometry into descriptive geometry. This does not mean that it cannot or even should not be done. The point is that the self-dependence of the science of descriptive geometry has not been curtailed nor diminished in any way by that study.

It is also quite natural that the research in the field of descriptive geometry, when performed by means of the purely descriptive geometry ideas, only serves better the self-dependence of that science.

Therefore, "the peculiar line," being not an "old" projective geometry tool, serves the self-dependence of the spatial science of descriptive geometry -- and well. When treated as an affinity line, imported from projective geometry, it does the opposite.

In the present continually critical position of the science of descriptive geometry in the school curriculum, that aspect of the self-dependence of descriptive geometry as a spatial science, seems to be of considerable importance.

The restoration of the role of descriptive geometry in the school curriculum in the space age may come only through practical recognition of that subject as (1) a most efficient spatial geometry and (2) as an irreplaceable self-dependent science.

Melding together the homology, affinity and the peculiar lines, and calling the third angle projection inadequate (p. 54) seems to depreciate descriptive geometry in these two important respects.

The only valid objective point of view calls for a right appraisal of actual values of the subject matters involved, without making them overly important or too negligible.

Finally it should be mentioned that from a purely applicatory standpoint, it may seem of no special importance how clearly one would discern between the affinity line and the peculiar line.

The situation, however, becomes entirely different -- when approached from the theoretical or purely mathematical point of view. Almost inconspicuous differences in the underlying axioms or seemingly insignificant fundamental statements in mathematics make a very big difference in the structures that are based on them and developed from them.

For one of many possible examples, let it be referred to the fact with which this article began.

Topology has one basic underlying axiom, which is: Seemingly, this statement is very simple and rather insignificant. Nevertheless, at the present time science is superior to projective geometry, which has been considered an "all geometry" for a very long time.

REFERENCES (Footnotes)

1. Morris Kline -- Projective Geometry -- an article in "The World of Mathematics" Vol. 1 pp. 622-641. Simon and Schuster, New York, 1956.
2. "Engineering Graphics Course Content Development Study -- Final Report," 1965 -- Paul M. Reinhard, Project Director -- Study, Headquarters, the University of Detroit.



Do you use graphics in your classroom?



Perspective

THE EDUCATIONAL VALUE OF GRAPHICS*

Frank A. Heacock
Professor of Graphics, Emeritus
Princeton University

For many years teachers of graphics have rightly stressed the importance of engineering drawing and descriptive geometry. It is an established fact that a working knowledge of the universal language of engineering drawing is indispensable for communication of technical data in all fields of engineering construction and industrial production. It is also well known that descriptive geometry methods are often used to advantage to solve three-dimensional problems, especially where vectors are employed to represent such factors as forces, time, and motion. In addition to its utility in communication and problem solving the study of graphics has important educational values which are discussed briefly in this article.

Graphics is the expression of visual thinking by means of views, graphs, and diagrams, which must appear in the mind before they can be drawn on paper. Thus the study of graphics develops mental vision, the ability to see things clearly in the mind. Students who have mental vision learn quickly and easily, because they think in terms of lifelike pictures that reveal their meaning at a glance. Visualizing the different aspects of a subject makes study more interesting and fruitful. This method of enlightenment by visual thinking is so rewarding that every engineering student should be taught how to use it effectively in various ways that will improve his ability to learn.

The visual nature of graphics makes it a valuable aid to teaching and learning. The study of graphics gives the mind a visual way of thinking and comprehending, called graphic insight, which opens up a direct path to complete understanding. Too many students adopt the rote method of study, memorizing facts and figures, rules and techniques, trying to find the true meaning of a problem, but not knowing where or how to look for it. In the study of graphics, the point of view and the direction of sight are vital considerations that must be mastered at the outset. Thus the graphics student acquires a reliable sense of direction and the ability to select a favorable point of view from which the most significant

aspects of a problem are immediately apparent. Often several points of view must be taken, one after another, in order to discover and appraise all the facts revealed by different aspects of a situation. This requires a flexibility of viewpoint as the attention is shifted from one aspect to another. It makes the mind alert and nimble, develops keener perception, and gives students a better understanding of principles and their useful applications.

Now, more than ever, young engineers must have imagination and the ability to use it effectively when they meet the challenge of our dynamic technology. The wonderful engineering achievements all around us today are the products of creative imaginations put to work a few years ago by forward-looking engineers. But a fertile imagination must have its roots deep in rich experience. Nothing takes the place of actual experience. Not found in textbooks, this real experience is gained on the job in industry, on construction, or at a research center. Engineering students and their instructors should get this firsthand experience in summer jobs. This background of knowledge concerning how things are accomplished where the action is should be supplemented by intensive reading in the technical journals with the regard to many different kinds of engineering projects. When it is nourished by experience and stimulated by the interest that experience generates, the imagination is developed by training so that it will grow and bear fruit in the form of bright, new ideas about better ways to satisfy needs. As graphics provides the best outlet for these ideas, a ready facility in graphic expression is the perfect partner for the creative imagination.

Invention is the useful contribution of a working imagination whenever progress demands a better way to get things done. Where the new idea involves only a change in method, the improvement is called an innovation, but if the idea is entirely original, unlike anything ever done before, it is a discovery. In any case, some knowledge of what is known as the prior art, gained by a study of similar applications already planned and tested, is a helpful guide to the creative imagination. When a new idea appears in the mind, it should be transferred immediately to paper in the form of a sketch in a notebook. This is the first step in

*Editor's Note: This was the last literary production of Professor Heacock, now deceased. He wrote it especially for the Journal of Engineering Graphics Division of Engineering Graphics.

Continued on Page 41

file to file

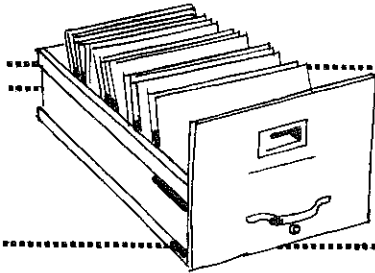

Many "on the line" teachers have ideas, suggestions, techniques, problems, and questions they would like to share with the society. "FILE TO FILE" provides the place for exchange of professional information. If you have an item for exchange, submit it to "FILE TO FILE," E. D. Black, General Motors Institute, Flint, Michigan.

ON AN APPLICATION OF DESARGUES' THEOREM

by

Robert W. Bosmo
Princeton University

The "Can You Solve This" problem of the Spring, 1965 JEG issue is admirably suited to solution using Desargues' Theorem of the projection geometry. This theorem may be stated as follows:

"If corresponding points of two coplanar figures lie on concurrent lines, then the points of intersection of corresponding lines of the figures lie on a straight line."

The given problem can be analyzed as follows. The intersection of the V-block with plane ABC is the same as the parallel projection of face DEF on ABC. Therefore, in the plane of Figure 2, corresponding points of two coplanar figures, one being face DEF and the second the section on ABC, lie on parallel lines. If the axis of affinity for these figures can be established, the section on ABC can be constructed.

The axis of affinity can be determined as follows: Points A and E are corresponding points of the two figures as are points B and G. Therefore, the intersection of lines AB and EG locate point H on the axis. Point C of plane ABC is also a point of face DEF. As a result, C is necessarily a point on the axis. The axis of affinity is the line passing through points H and C.

The section can now be obtained in the following manner:

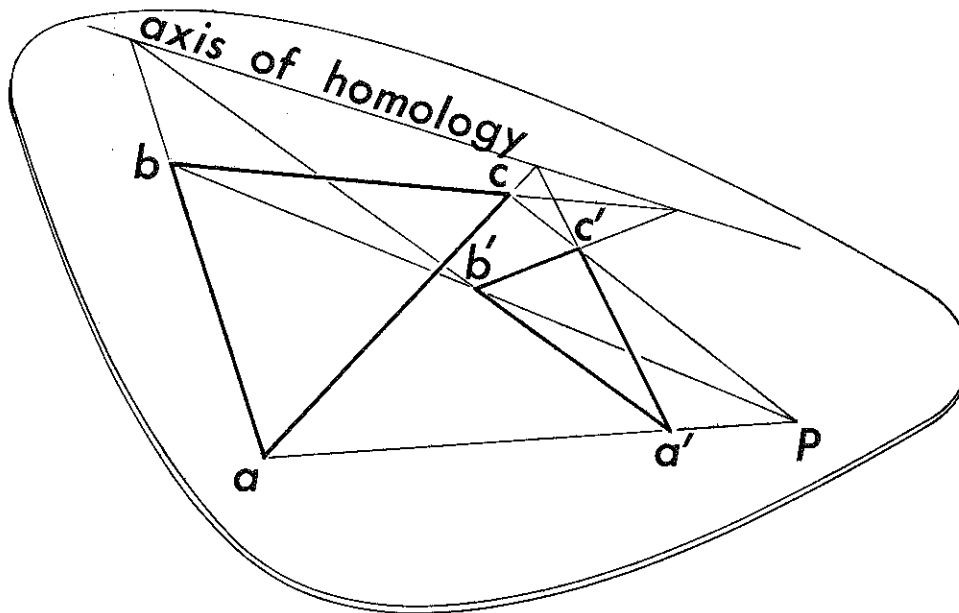

Figure 1

Figure 1 pictorially represents the theorem. The straight line referred to above is labeled as the "axis of homology" in Figure 1 since P, the point of concurrency, is a real point of the plane. The point P can also be an ideal point of the plane, i.e., the point in which parallel lines intersect. In this latter case, the straight line is called the "axis of affinity."

1. Line EF intersects the axis of affinity at point J. The corresponding line of the section must pass through J and A since A and E are corresponding points. The line AK of the section results.

projection and the solution procedure remains unchanged.

The point that is intended to be made with this paper is the recollection of -- and perhaps in some instances, a first exposure to -- the beauty and simplicity of Desargues' Theorem. Of importance, however, is the realization that this theorem is not restricted to obvious problems in projection such as the example worked here. The February and November, 1962 issues of this journal contain articles by V. P. Borecky that show proof of Desargues' Theorem and some engineering applications that are not strictly projection type problems.



Answer to problem "Can You Draw the Right-end View?" contributed by E. W. Knoblock, The University of Wisconsin - Milwaukee, February, 1966, Vol. 30, No. 1.

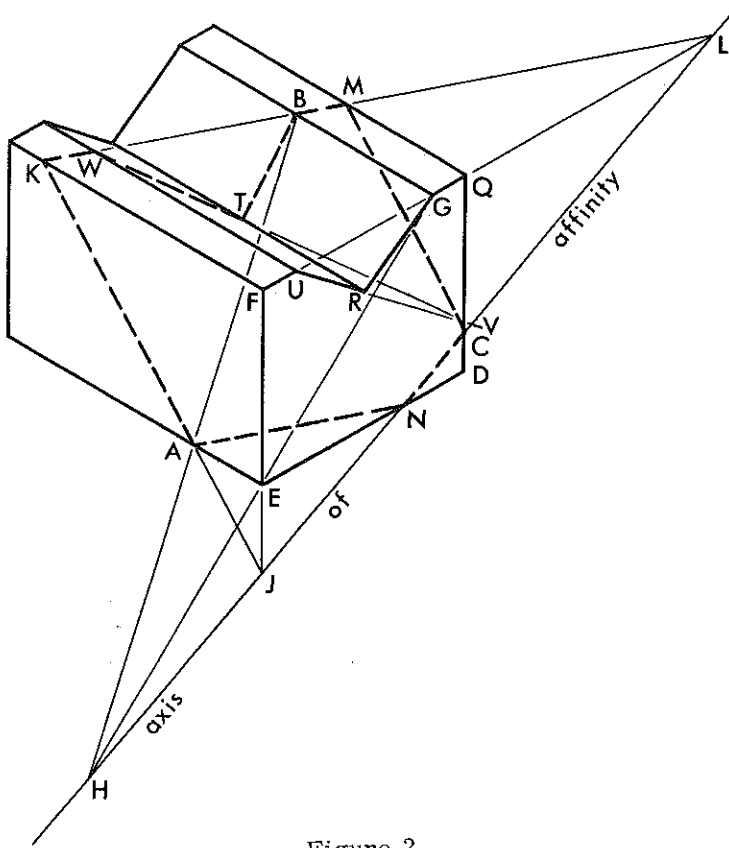
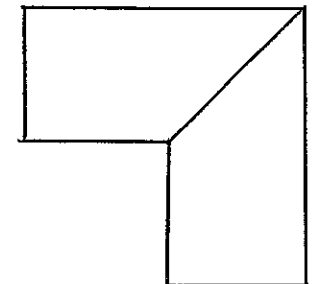
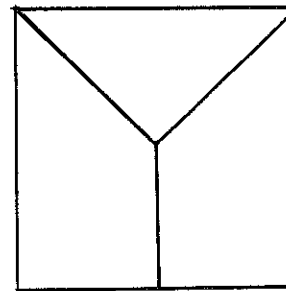
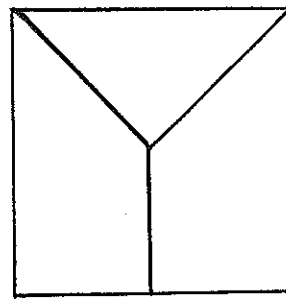

Figure 2

2. Line FG of the face intersects the axis at L. F and K are corresponding points, therefore KM of the section can be drawn. Observe that this line passes through B.
3. Line DE of the face intersects the axis at N. Line AN of the section corresponds to EN of the face.
4. Line DQ of the face intersects the axis at C. M and Q are corresponding points, therefore MC of the section can be drawn.
5. Line RU of the face intersects the axis at V. U and W are corresponding points, therefore WT of the section can be drawn.
6. Connect points B and T, N and C to complete the section.

Notice that steps 1 through 5 describe identical and very simple procedures. The determination of the axis of affinity was also easily accomplished being essentially the inverse of the succeeding five steps.

Desargues' Theorem is entirely general for problems of this type. The faces of the object being sectioned need not satisfy special conditions such as parallelism. In addition, the object can be represented in either axonometric or perspective



Continued on Page 54

A drawing is first a thought before it is recorded.



Those who resist the idea that their writing needs improvement are often the first to object if they are assigned readings in poorly written books.



James S. Rising, Cont.

In his distinguished career as a classroom teacher and administrator, Professor Rising has touched the lives of thousands of engineering students in the formative years of their professional education. The esteem in which he is held by former students and the loyalty of his staff are evidences of his warm personality and effective leadership.

Jim and Mildred Rising are the parents of two sons, Edward J. and Donald M. The former is Assistant Dean of Engineering at the University of Massachusetts.



Robert H. Hammond, Cont.

He is the principal author of the textbook and workbook, "Engineering Graphics for Design and Analyses," widely adapted in engineering schools.

Colonel Hammond is presently living in Raleigh, N. C., with his wife, Shirley, and two children, Terry Lee, and Robby. He has one other son, Harry (Steve) Hammond, a third classman (sophomore) at the U. S. Military Academy.

Following his retirement, Colonel Hammond accepted a position as assistant director of the Freshman Engineering Division at North Carolina State University in Raleigh, N. C.



CITATION

Frank Oppenheimer, Gramercy Guild Group, Inc., has been elected to membership in the ASPEN SOCIETY OF FELLOWS. His election to membership by the trustees of the Aspen Institute for Humanistic Studies was because of Mr. Oppenheimer's "interest, activity, and leadership toward the strengthening of the humanities and his influence in clarifying the purposes and destiny of man."

Membership to the Aspen Society of Fellows is chosen from leaders in industry, the professions, and public affairs who are actively engaged in strengthening the humanities to give greater meaning to the life of man and wiser direction to society.

The purpose of the Aspen Executive Program is to broaden the perspective and to excite the imagination of each participant through an informal, intensive exchange of ideas.



IN MEMORIAM



Frank A. Heacock

Professor emeritus, Frank Ahern Heacock, retired Chairman of the Department of Graphics and Engineering Drawing at Princeton University, a nationally known teacher, practicing engineer, and scholar; a long time member of the Division of Engineering Graphics of the American Society for Engineering Education; and an active participant in its affairs, even after his retirement from teaching, died on Wednesday, June 15, 1966 in Princeton, New Jersey.

Professor Heacock was a recognized authority on the graphical solution of technical problems in the fields of Science and Engineering. He was a frequent contributor to technical publications and the author of several books. Other honors included membership in Sigma Xi, Tau Beta Pi, and Phi Beta Kappa. He served the Engineering Graphics Division, as well as the American Society for Engineering Education in many capacities, including membership on the General Council, Chairman of the Division of Engineering Graphics, and Editor of the Journal of Engineering Graphics.

In 1957 he received the Distinguished Service Award of this Division.

He was a devoted husband and father and was loved by all who knew him. He was a distinguished gentleman in bearing and manner whose presence lent dignity to any occasion.

The Engineering Graphics Division recognizes its great loss of a devoted friend and wishes to express its deepest sympathy to Mrs. Heacock and children.

It is recommended that this Memorial be placed in the minutes of the Division and that copies be sent to his family.

Ralph Northrup

Matt McNary

James Rising

A. P. McDonald, Chairman



IN MEMORIAM

The staff of the Department of Graphic Science of Northeastern University submits the following resolution to the Engineering Graphics Division of the American Society for Engineering Education concerning the death of James J. Devine, Associate Professor of Graphic Science, on March 19, 1966.

Professor Devine received his Bachelor of Science Degree in Civil Engineering from Rhode Island State College in 1927 and his Master of Science Degree from Brown University in 1936.

After receiving his Bachelor's degree he was employed for a short period of time by the Telephone Company but then returned to the profession of teaching to which he devoted his greatest efforts. Professor Devine came to Northeastern University in 1937 where he taught Engineering Drawing and Civil Engineering until 1939. Since 1935 he has been associated principally with the Drawing Department and was a member of that Department -- now the Graphic Science Department -- until his death.

In 1939 Professor Devine was appointed to the faculty of Lincoln Institute, which is an evening technical school at Northeastern University serving as a member of its Academic Program Committee and as Assistant Department Chairman of the Department of Engineering Drawing. His contributions to Lincoln Institute, now Lincoln College, have been many with the reputation of having a sincere manner, quiet competence and the highest dedication to his students, placing him among those who in the highest sense are known as educators and gentlemen.

The twenty-nine years of service to Northeastern University were continually marked by a keen sense of loyalty and devotion to the school, his work, and especially to his students. Professor Devine took great pride in his career as a teacher and was constantly aware of his responsibilities which he discharged with enthusiasm. He delighted in the accomplishments of his students and was always ready to help those who stumbled which indicated his full commitment to the needs of young people who attended his classes.

His colleagues in the Graphic Science Department of Northeastern University attest to his spirit of cooperation and support. Many new young teachers were helped and advised by this experienced professor. Professor Devine was constantly active in investigating new developments in Graphics and passing them on to his colleagues and students. We will miss him.

James J. Devine was also active in his community particularly in his church where he served in many capacities including the administration of the Sunday school. His summers were characterized by attendance at various summer institutes and conferences in his academic field. He was active in national and local levels of the American Society for Engineering Education as well as Phi Kappa Phi, a national scholastic honor society. He was a member in good standing of the Boston Society of Civil Engineering.

Professor Devine was the author of short articles published in the ASEE Journal of Engineering Graphics as well as of a text in the graphical presentation of statistics as taught by his colleagues for several years.

Submitted by
Staff of the Graphic Science Department
Northeastern University

By means of this resolution, the members of the Engineering Graphics Division of the American Society for Engineering Education wish to express their deepest sorrow at the loss of so valued a colleague.



ANNUAL ENGINEERING GRAPHICS DIVISION

Descriptive Geometry Award

Presentation by I. L. Hill

Washington State University
Pullman, Washington - June 22, 1966

The Descriptive Geometry Award Committee is pleased to announce that the award this year which includes a certificate and a \$100 cash prize goes to Dr. Luisa Bonfiglioli for her paper entitled "Parallel Projection for Euclidean Geometry of

Continued on Page 28

Descriptive Geometry Award, Cont.

Four Dimensions." This paper was presented at an Engineering Graphics Seminar in November, 1965 and was published as Report No. 18 of the Technical Seminar Series of Princeton University.

Dr. Bonfiglioli is a visiting Research Post-Doctoral Fellow to the Department of Graphics and Engineering Drawing of Princeton University. She is a leading world authority in the field of Descriptive Geometry and is now on leave from the Israel Institute of Technology. She is doing research in theoretical graphics and in descriptive geometry of higher spaces plus a series of lectures and seminars. In addition, she is engaged in research using projectors and motion to develop visual concepts involving descriptive geometry.

In addition to the certificate, the cash prize of \$100 is made possible by the generosity of a most loyal friend of the Division -- Mr. Frank Oppenheimer of the Gramercy Co. who made the presentation. The Division is most grateful for his continued support.



Engineering Graphics - Static or Dynamic, Cont.

Design begins with a consideration of the numerous possibilities and converges in the form of approaches, material selection and components to an acceptable answer. Design requires an objective judgment by completely testing all possible subjective impressions against design criteria to arrive at an acceptable conclusion.

Great technical skills in the practice of creative design is difficult to contain within a single definition. The designer's work may begin with research and study of the customer's needs. Research and design require essentially different approaches and attitudes of mind. Research is divergent; it begins with a glimmer of an idea and enlarges as the idea takes form and direction. Research opens the way to progressively larger problems; development and engineering design reduce the magnitude of the problem and evolve practical applications as progress in research is made.

Engineering graphics is one means of closing the gap of misunderstanding often occurring between the research scientist and development engineer. We of the Engineering Graphics Division must keep alert to new developments in both the science and engineering areas. Our college courses in engineering graphics must change with these developments if graphics is to continue to be the dynamic force for progress which it has been in the past.

E.D.B.



Officers and Committees, Cont.

T. Dolan, Tri-State College
J. S. Dobrovolny, University of Illinois
K. E. Botkin, Purdue University
J. H. Earle, Texas A & M University
A. L. Hoag, University of Washington
E. W. Jacunski, University of Florida
R. S. Lang, Northeastern University
E. C. Schamehorn, Rochester Institute of Technology
S. M. Slaby, Princeton University
R. D. Springer, University of Minnesota

MEMBERSHIP COMMITTEE

J. H. Earle, Texas A & M University, Chairman
C. W. Chance, University of Texas
W. B. Clement, Clemson University
M. M. Jones, Lake Sumter Jr. College
A. P. McDonald, Rice University
F. Oppenheimer, Gramercy Guild Group, Inc.
W. B. Rogers, U. S. Military Academy
E. C. Schamehorn, Rochester Institute of Technology
M. G. Thomas, Keuffel & Esser Co.
J. H. Whenman, Worcester Poly Institute

SCOPE OF ENGINEERING GRAPHICS

J. S. Dobrovolny, University of Illinois, Chairman
A. F. DeVaney, Amarillo College
W. H. Francis, Auburn University
J. L. Garrard, Oregon State University
E. B. Garrison, University of Toledo
P. H. Hill, Tufts University
R. K. Jacobs, Georgia Institute of Technology
H. T. Jenkins, University of Michigan
T. R. Long, West Virginia University
F. H. Meyer, State University of Iowa
E. V. Mochel, University of Virginia
M. Norris, Miami-Dade Junior College
A. C. Risser, Wichita State University
H. J. Schwebke, University of Wisconsin
W. A. Wockenfoos, University of Maryland

TEACHING METHODS & TECHNIQUES

E. C. Schamehorn, Rochester Institute of Technology, Chairman
C. J. Buckman, University of Arizona
J. B. Dent, Virginia Polytechnic Institute
D. M. Fullmer, West Virginia Institute of Technology
L. O. Johnson, New York University
H. G. Kinner, Rensselaer Polytechnic Institute
K. E. Kroner, University of Massachusetts
R. D. LaRue, Colorado State University
H. E. Perkins, University of North Dakota
C. G. Sanders, Iowa State University
W. F. Schneerer, Case Institute of Technology

1967 SUMMER SCHOOL PLANNING COMMITTEE

P. H. Hill, Tufts University, Chairman
E. D. Black, General Motors Institute
P. Z. Bukeley, Stanford University
J. S. Dobrovolny, University of Illinois
M. McNeary, University of Maine
W. B. Rogers, U. S. Military Academy
H. Krause, Michigan State University
J. R. Burnett, Michigan State University



CREATIVE PRODUCT EVOLVEMENT

by J. Liston, P. E. Stanley

Published 1965
Price \$5.00

190 pages, 8½" x 11", -- a book which is profusely illustrated with example cases of new-product evolvement, and contains a large number of practice problems particularly designed to stimulate imaginative thinking. Many of these problems are based on real situations that offer the challenge which comes from knowing that a good answer might have commercial potential.

Unique in its field, and particularly emphasizing the methods of synthesis, a step-by-step procedure is presented for conceiving, describing, and proving ideas and proposals for new and better products.

Chapter titles are: 1. *Preparatory Steps in Evolving a Complex Product*. 2. *Conceptual Methods and Techniques in Creative Product Evolvement*. 3. *Spatial Visualization*. 4. *Disclosures and Patents*. 5. *Feasibility and Optimization Studies*. 6. *Feasibility and Optimization Studies with Analog Computers*. 7. *Feasibility and Optimization Studies with High-Speed Digital Computers*. 8. *Experimental Confirmation of Feasibility*. 9. *Planning the Feasibility Test Facilities*. 10. *Proposal Reports for New Products*. *Appendix: Practice Problems in Creative Synthesis*.

*DESCRIPTIVE GEOMETRY PROBLEMS and **ADDITIONAL DESCRIPTIVE GEOMETRY PROBLEMS

by S. B. Elrod, C. H. Zacher, H. F. Gerdorf

*Published 1962
**Published 1965
Price \$4.50 (for both)

*128 problem sheets, 8½" x 11", on good quality paper, perforated and bound into a book.

Appropriate for an extensive course of 90-100 lab hours. Content includes: basic orthographic projection, fundamental spatial relationships of elements; applications of descriptive geometry to design and manufacture. There is extensive coverage of intersections and developments, including ruled surfaces; also, axonometric and perspective projection are treated.

**ADDITIONAL, -- includes a number of problems on: *Lofting, Compound Locus Relations*, - also includes improved instruction and variations of certain problem sheets in the 1962 set.

WORKSHEETS FOR INTRODUCTORY GRAPHICS - FORM A

by J. N. Arnold, M. H. Bolds, S. B. Elrod, J. H. Porsch, R. P. Thompson

Published 1958
Price \$4.00

One hundred sheets, mostly 8½" x 11" with a few 11" x 17", on good quality paper, perforated and bound into a book.

Principal topics are: *Lettering, Geometry, Multiview Drawing, Pictorial Drawing, Intersections, Developments, Contoured Surfaces, Functional Design*; also, a few sheets each on *Vectors, Graphical Calculus, Empirical Equations, Representation of Data and Equations*.

GRAPHIC AIDS IN ENGINEERING COMPUTATION

by R. P. Hoelscher, J. N. Arnold, S. H. Pierce

1963 Printing
Published 1952
Price \$5.75

This well-known text of 197 pages, 6" x 9", in hard covers, deals with alignment charts, empirical equations, the design of special slide rules, and the use of the standard slide rule. Examples are numerous, and there are problems at the end of each chapter.

The seven chapters are: (1) *Standard Slide Rules*, (2) *Empirical Equations from Engineering Data*, (3) *Alignment Charts*, (4) *Graphical Calculus*, (5) *Alignment Charts with Determinants*, (6) *Special Slide Rules*, (7) *Movable-scale Nomographs*.

Formerly available from McGraw-Hill; now a Balt book.

Examination copies of any of these are available upon request.

BALT PUBLISHERS

308 STATE STREET

WEST LAFAYETTE, INDIANA 47906

The Thought Model, Cont.

study* since copies are available upon request. Suffice it to state that the results of the study indicates that a significant change in student performance can be brought about by the use of the thought model method in teaching the fundamental principles of orthogonal projection and their application to the solution of space problems.

Since the completion of this study in 1962, we have continued our experimentation using television. During this school year (1964-1965) 12 T.V. lectures were developed and used in our freshman graphics classes. Each lecture of approximately 30 minutes was followed by 20 minutes of "live" discussion.

In the first three weeks of the fall semester, 1964, the first six lectures (two per week) were presented via television. These lectures included the following topics:

1. "Introduction" -- the engineering profession; the rapid development of technology; the need for thorough preparation in mathematics, physics, chemistry, and graphics; the engineering sciences; and humanities; and the role of graphics in engineering design.
2. The two fundamental principles of orthogonal projection.
3. The determination of visibility of solids; and the interpretation of orthographic views.
4. True length, grade and bearing of line segments; applications.
5. Intersecting, skew, parallel and perpendicular lines; applications.
6. Point view of a line; edge view of plane surfaces; connector problems; and applications.

Each T.V. presentation was followed by "live" discussion.

During the next three weeks, six lectures were presented "live" (no T.V.). Included were the following topics:

7. True shape of plane surfaces, and applications.
8. Angle problems; applications.
9. Developments.
10. Intersections -- basic problems.
11. Intersections of solids.

12. Vector quantities and vector diagrams; concurrent noncoplanar force systems.

A report of this experiment has been prepared, but is not ready for distribution at this time. Nevertheless, a few highlights are appropriate:

As the students see it with respect to T.V.:

- a. The T.V. method is better for the simpler material.
- b. There are mechanical advantages in making it easier to hear and see.
- c. More material can be covered in the time available.
- d. The additional planning for a T.V. "performance" motivates the instructor to produce especially clear sketches and well organized lectures and thus aid in the presentations.

Now with respect to the "live" presentations the study revealed the following:

- a. The "live" method is better for the more difficult material and is more helpful in pointing out the areas for more concentrated study.
- b. The live method allows for immediate questions related to the difficult material.
- c. The instructor can sense when students are having trouble absorbing what he is saying just by noting that there are blank looks, coughs, shuffling feet, and no notes taken; he can then back up and review the material until the symptoms disappear.
- d. The presence of live students also motivates the teacher to throw out clues as to what is really important, often doing so in a very informal way, again something which may not be done easily during the "formal" T.V. presentation.

In both the T.V. and live presentations, the Thought Model method was used to further the development of visualization.

Our study has shown that:

1. The use of the thought model method greatly enhances the student's ability to visualize geometrical and physical configurations.
2. The performance of students in dealing with the fundamentals of orthogonal

*Supported by a grant from the U. S. Office of Education.

THE SPACING DIVIDER

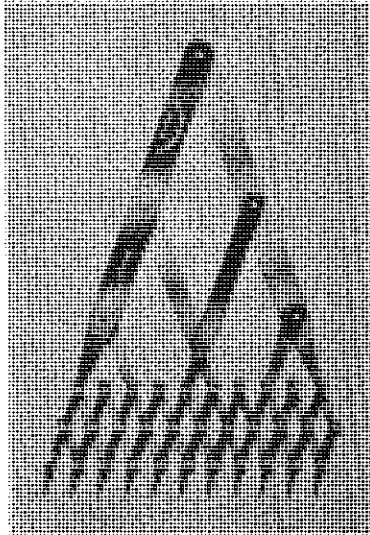

No. 2960—6 INCH
(ILLUSTRATION HALF SIZE)

This instrument consists of eleven points so adjusted that they divide their variable setting into ten or less equal parts. It can also be used inversely to give multiples up to ten and in graphic solution of ratios. Adjustable distance between points on the 6 Inch Instrument is minimum $\frac{3}{16}$ " , maximum $\frac{5}{8}$ " and on the 12 Inch minimum $\frac{1}{4}$ " , maximum $1\frac{1}{4}$ " .

Catalog on Request Covering:

Drawing Instruments

Protractors

Rolling Parallel Rules

11 Pt. Spacing Dividers

Drafting Scales

S.S. Straightedges

S.S. T-Squares

S.S. Triangles

Circular and Linear Engraving

for the

DRAFTING ROOM—PATTERN LOFT—LAYOUT TABLE

THEO. ALTENEDER & SONS

Makers of Fine Instruments Since 1850

1217 Spring Garden Street

Philadelphia 23, Pa.

which we are accustomed.

Therefore take the five fundamental points of the new space and connect them in this manner: Three of them two by two in order to generate (Figure 7) a triangle 1-2-3 and after that these three points to each one of the remaining two points 4 and 5.

The Figure 1-2-3-4 is nothing else than a pyramid whose edges can be prolonged to infinity. But we know that four non-coplanar points determine a space of three dimensions; therefore the points 1,2,3,4 and in the same way 1,2,3,5 determine two spaces D_3 named cells that have the base in common but are not identical because the point 4 is distinct from the point 5.

At this point we can summarize the following facts:

- I. a. A line is determined by means of two points (Figure 8).



Figure No. 8

- b. A plane is determined by means of two lines (Figure 9).

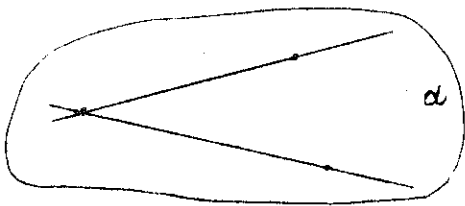

Figure No. 9

- c. A space D_3 is determined by means of two planes (Figure 10).

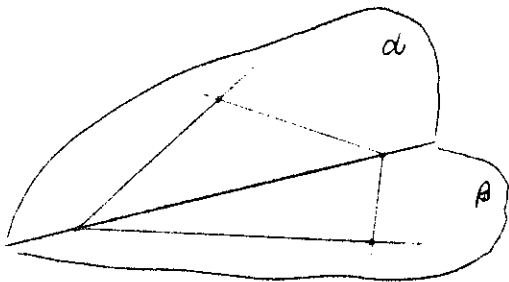

Figure No. 10

- d. A space D_4 is determined by means of two cells (See Figure 7).

- b. The elements of a plane are points and lines.
- c. The elements of a space D_3 are points, lines, and planes.
- d. The elements of a space D_4 are points, lines, planes and pyramids determining spaces D_3 called hyperplanes. (Figure 11). Two hyperplanes are identical if and only if they have their four fundamental points coincident.

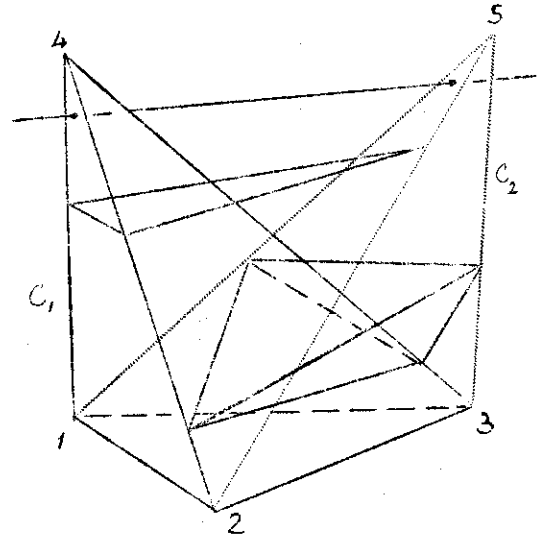

Figure No. 11

- III. Elements embedded in the space D_4 keep their own peculiar properties; i.e., points and lines belonging to a certain plane, behave according to the laws of the plane geometry only on this plane and points, lines and planes belonging to a certain hyperplane, behave according to the laws of the solid geometry only inside this hyperplane. But the space D_4 , as an amplified space, has laws of its own different from the laws known to us.

Only very few of them will be discussed here.

We will determine the space D_4 by means of the two cells 1-2-3-4 = C_1 ; 1-2-3-5 = C_2 or by means of three fundamental planes; 1-2-3; 1-2-4; 1-2-5. (Figure 12).

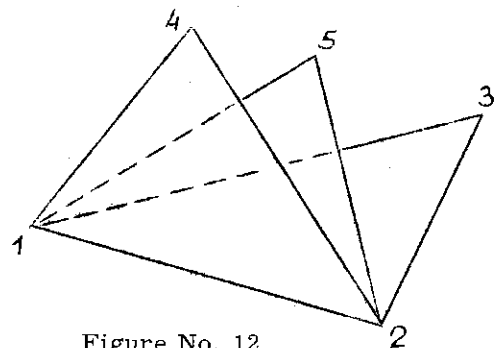
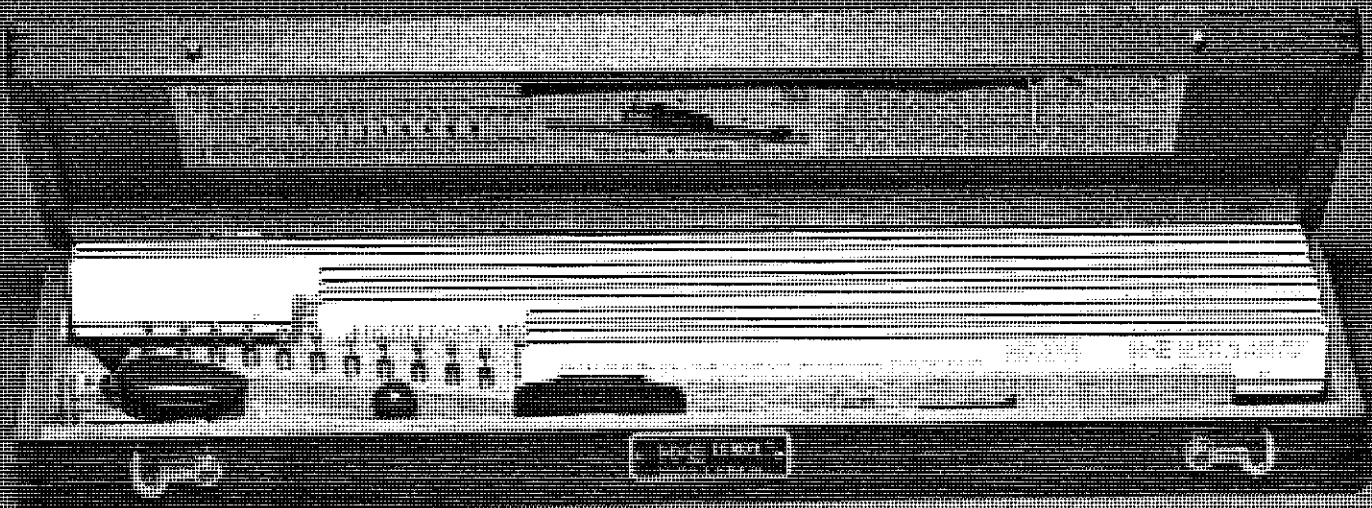

Figure No. 12

- II. a. The elements of a line are points.



How do you improve
on a masterpiece?

Here's how...The LEROY® II LETTERING SET

New one-piece tray that can lift out of the case and put on your working surface. More convenient; and functionally designed to hold everything in minimum space.

New pen holder. For using Reservoir Pen points independent of the scriber (with straightedges, curves, etc.) You used to have to buy this separately.

Same old name. It's a good thing for you this hasn't changed. Because the name K&E on a lettering set means the unequalled precision and craftsmanship that created the lettering set concept, and made it an international success. Imitated but never equalled.

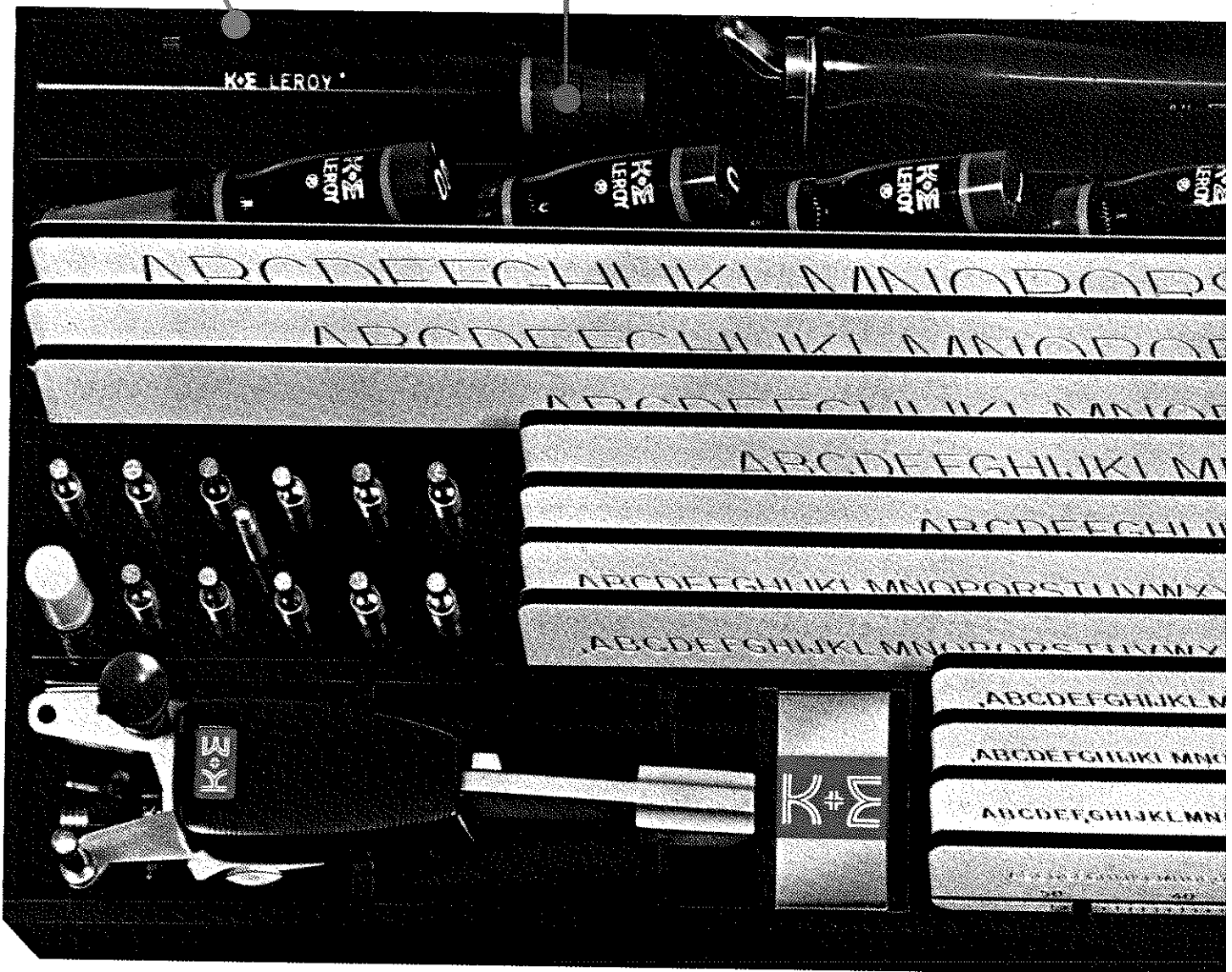

New scriber. It isn't easy to make a good thing better. But we've done it. For changing points there used to be a clamp screw. Now there's a better way. Just gently press a simple spring-action bar on the side of the scriber. You had to be careful where you set the old LEROY scriber (to keep the inked point off your drawing). Now just flick a little lever and a leg pops down out of the scriber, lifting that side of it and holding the point up in the air. (Neat, huh?) There's more. The screw that changes the lettering angle (you can draw vertical or slanting letters with the same template, you know) sticks out from the scriber more now, so it's easier to turn. And the whole scriber is a shade easier to work with because it's been functionally redesigned for a more comfortable grip.

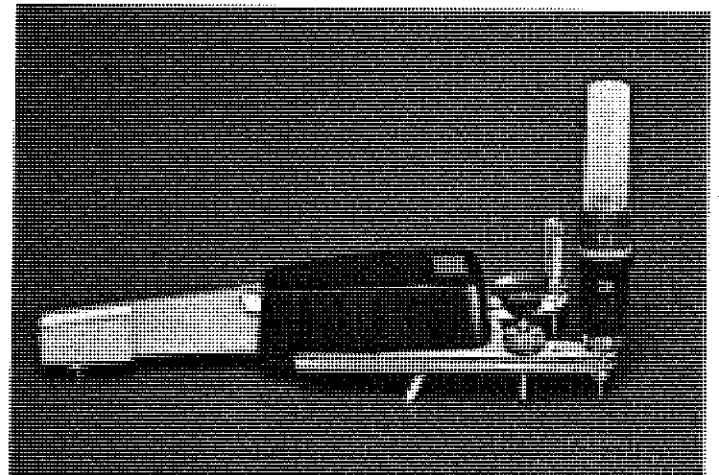

New Reservoir Pen storage. You used to have to have a separate box for Reservoir Pens. We think everything in one place is a better idea. The Reservoir Pen is one of the many ways K&E has refined and improved on the LEROY Lettering Set over the years. You get hours of drawing between cartridge refills; and you can cap and reuse it tomorrow without cleaning. (A set of regular pen points is also included in LEROY II.)

New price. With all these improvements, a LEROY Lettering Set has to cost more now, right? Wrong. Used to be about \$109. It still is (without the Reservoir Pens). Incredible, isn't it! About \$130 with the Reservoir Pen Set. You can buy the new set without Reservoir Pens if you like, but we'd like to sell the sets with them wherever possible (for your own good, as well as ours).

New slanted template storage. So you can see what's what, select the one you want at a glance. (Templates used to be stored straight-up-and-down, so you had to lift to see the numbers.) The standard templates for engineering drawing are included in the set and there are over 300 different other templates now available. Special templates will be produced on order.

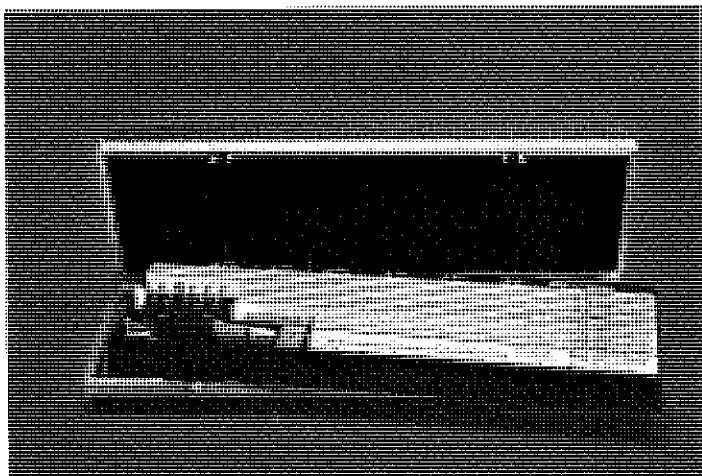
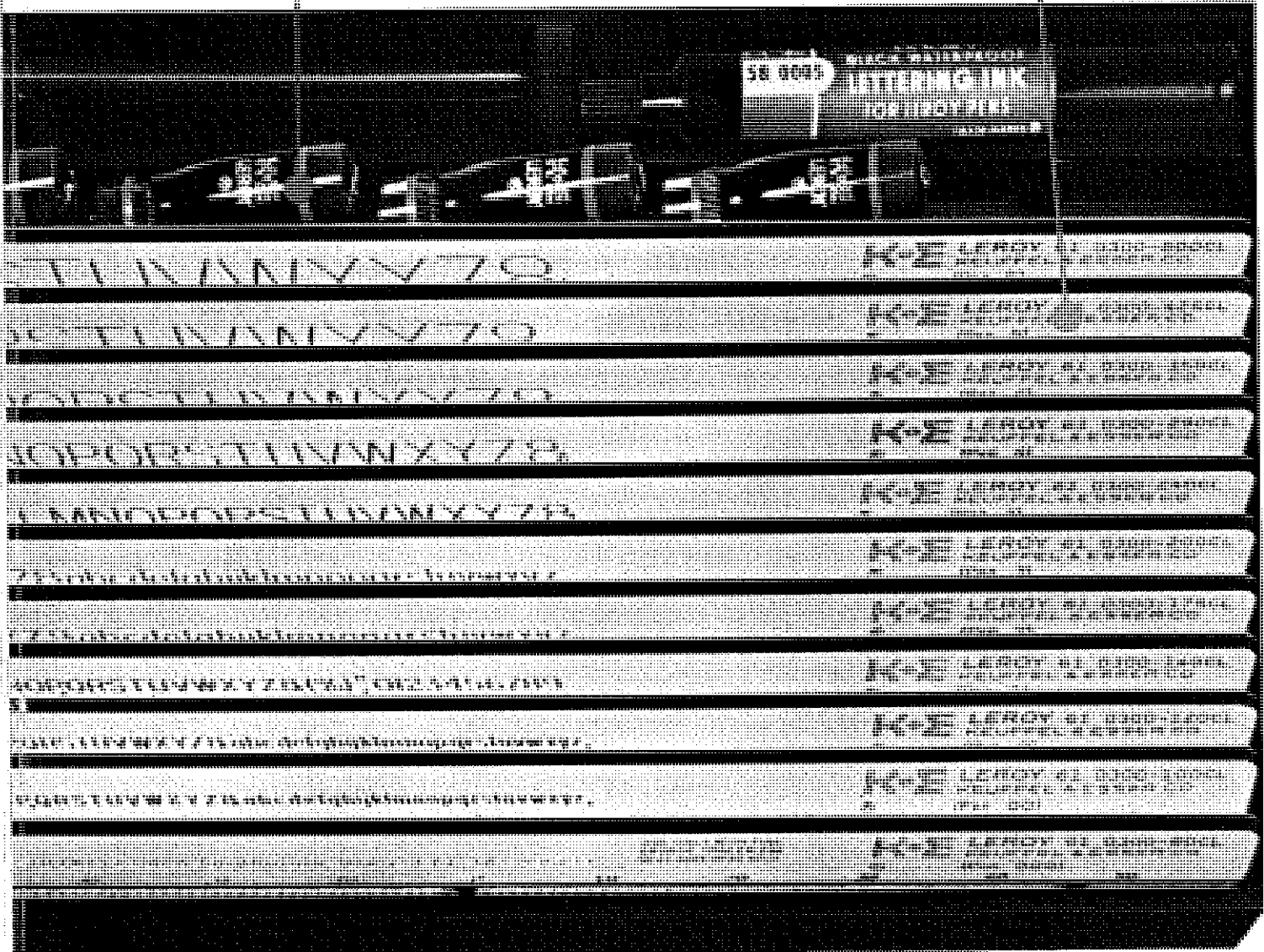

Here's the new package. The convenient tray drops into this attractive new protective case for storage and carrying around. Covered-down inside lid holds everything snug, so they don't jiggle around. Metal reinforced outer case. We abandoned the old mahogany case with reminiscent regret. It was handsome, but the new case resists moisture, warping, and dust better. And is more durable. That's about it. The new LEROY Lettering Set. LEROY II. Like the new LEROY catalog? Write Keuffel & Esser Co., Hoboken, New Jersey.



CREATIVE PRODUCTS
FOR THE CREATIVE ENGINEER
KEUFFEL & ESSER CO.

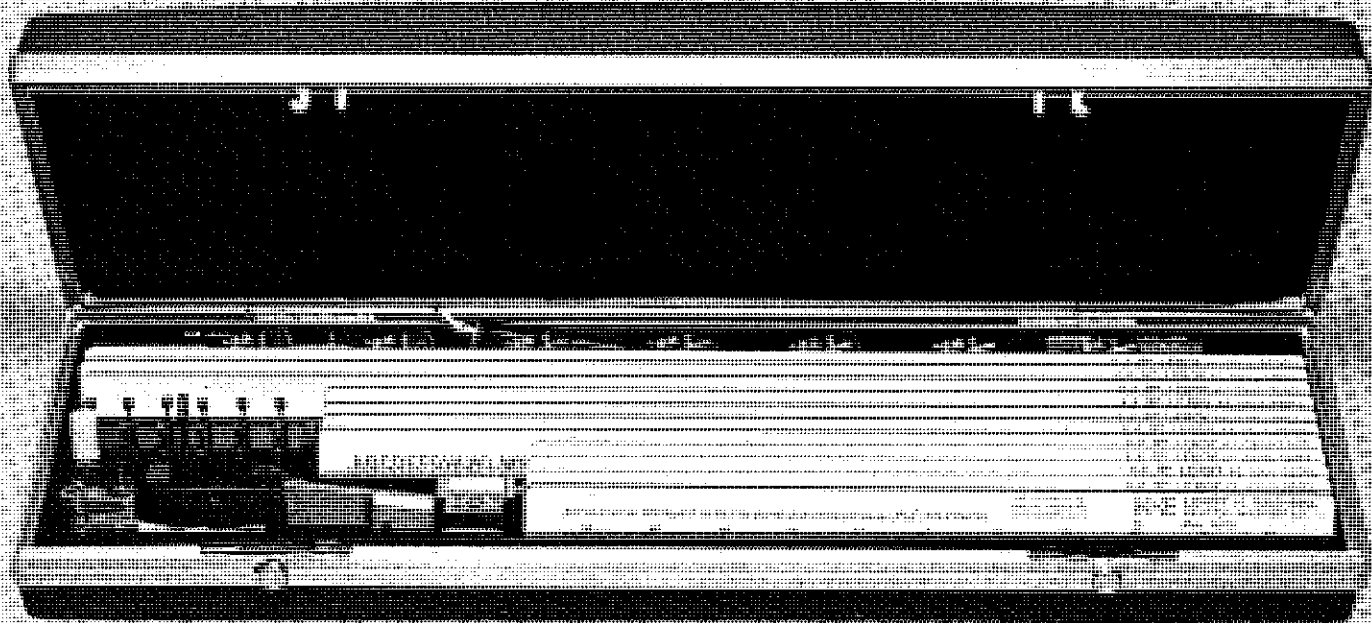

Why do you improve on a masterpiece?

Well, to make it even more of a masterpiece of course. But some people wouldn't bother. You know... the "leave well enough alone" school.

Not being perfect is no disaster. Not trying is.

The easy thing, rest on your laurels and accept the rewards.

The hard thing, work for years on possible improvements. Tear it apart. Ask people and use it. Put it under the magnifying glass of skepticism. Examine. Explore. Then put it back together again... on new terms and with new materials if need be.

This is easier, silly, tough when you've got a particularly successful product going for you already. Like the famous Lettering Set. (Since its introduction over a generation ago, Letter has become a worldwide success... copied but never equalled, let alone improved.)

The temptation is to let things hang.

We resist temptations like that.

(P.S. Our attitude toward Letter equipment carries over to all other our attitude toward our entire line of office products for engineers and draftsmen.)

Keuffel & Esser Co., 100 West 42nd Street, New York, N.Y. 10018

KEUFFEL & ESSER CO.

Theorem 1. A line and a hyperplane intersect at "one" point*. The line r is determined by means of two points that can belong to one single cell or each one to one of the two cells.

Suppose that the two points belong to C_1 ; then r must intersect the base 1-2-3 at a point that belongs also to C_2 . (Figure 13).

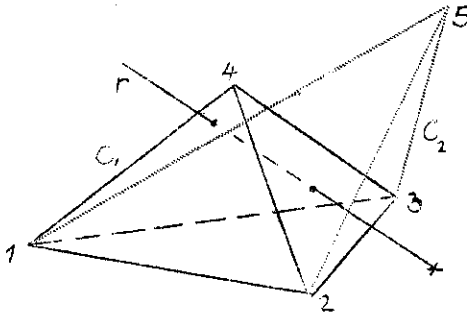

Figure 13

Another point of intersection between C_2 and r cannot exist otherwise C_1 and C_2 will have four points in common and will be coincident.

This proves the first part of the theorem. If the points belong one to C_1 and the second to C_2 (Figure 14) then r cannot intersect C_1 or C_2 in other points (even point of the base 1-2-3) for the same reason explained before.

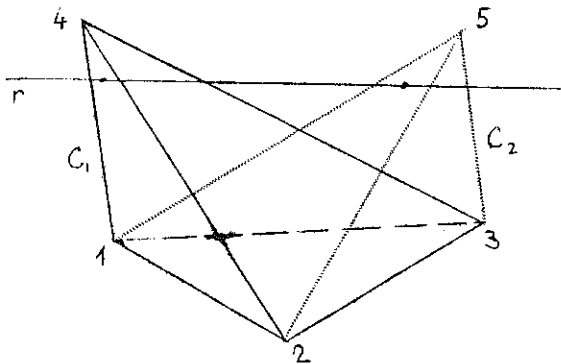

Figure 14

Theorem II. A line and a plane not belonging to the same hyperplane do not intersect.

Suppose that r belongs to C_1 and α to C_2 (Figure 15). If r could intersect α at a certain point R then C_1 and C_2 would have four points $R, 1, 2, 3$, in common and would be coincident.

Theorem III. Two planes not belonging to the same hyperplane intersect at "one" point.

*Remark. All the theorems are proved taking the cells as examples of hyperplanes; but each theorem can be generalized taking a new system of reference and using the previous cells as general hyperplanes of D_4 .

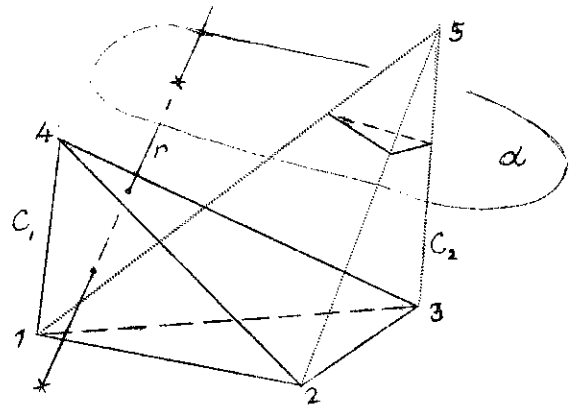

Figure No. 15

Suppose that α belongs to C_1 and β to C_2 . (Figure 16). Then α must intersect the base 1-2-3 along

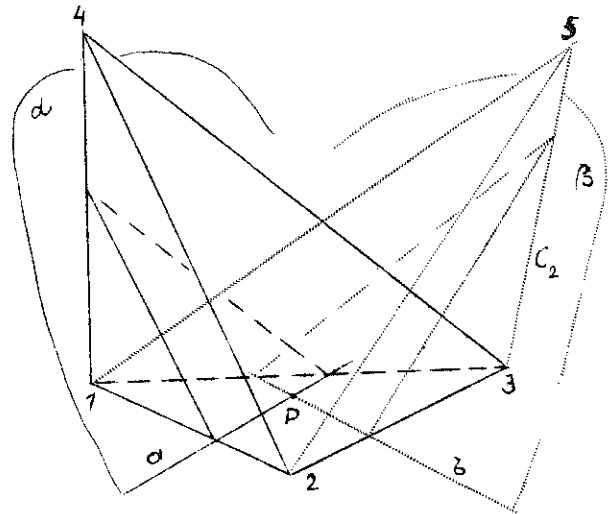

Figure No. 16

Suppose that α belongs to C_1 and β to C_2 . (Figure 16). Then α must intersect the base 1-2-3 along a line and β along a line b . a and b are coplanar, therefore they intersect at a point P . Besides P there are no other points in common to α and β because otherwise the cells are coincident.

In addition the lines a and b cannot coincide otherwise the two planes α and β determine a hyperplane to which they belong.

Theorem IV. Two hyperplanes intersect along a plane. The two cells C_1, C_2 give the proof for this theorem. From the previous theorems it follows that: a plane and a hyperplane intersect along a line; three hyperplanes intersect along a line and four hyperplanes at a point.

The concept of perpendicularity is introduced as an extension of known definitions.

In case of coplanarity a line is perpendicular to another line when it intersects the second one and forms with it an angle of 90° degrees.

A line is perpendicular to a plane when it intersects two lines of the plane and forms with them angles of 90° degrees.

So a line is perpendicular to a hyperplane when it intersects three distinct non-coplanar lines of the hyperplane and forms with them angles of 90° degrees.

Theorem V. All the perpendiculars to a line at one point of it belong to a hyperplane. (Figure 17).

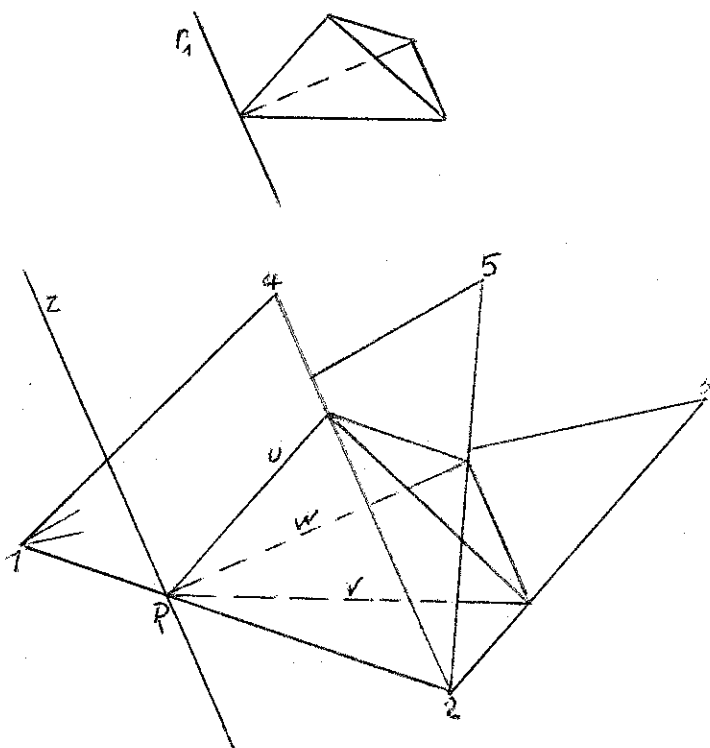

Figure 17

Refer the given line r to the three fundamental planes 1-2-3; 1-2-4; 1-2-5 and suppose that it intersects the side 1-2 at the point R .

Then r connected to each one of the three fundamental planes forms three distinct hyperplanes.

It follows that inside the hyperplane determined by r and the face 1-2-4 there exists only one line u of 1-2-4 perpendicular to r and so inside the hyperplane r ; 1-2-5 only one line w of 1-2-5 perpendicular to r and inside the hyperplane r ; 1-2-3 only one line v of 1-2-3 perpendicular to r .

The three lines u, v, w determine a hyperplane which is perpendicular to r according to the definition.

If we take a line r_1 parallel to r and through any point of it we draw lines correspondingly parallel to u, v, w we get the generalization of the theorem.

This theorem can be reversed and then:

Theorem VI. Through a certain point of a hyperplane there is one and only one line perpendicular to it.

Definition I. Let α be a plane determined by means of two concurrent lines a and b (Figure 18).

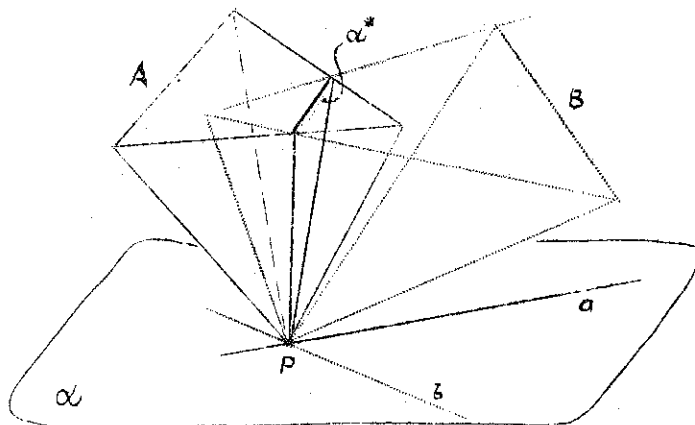

Figure 18

Through P draw the hyperplane A perpendicular to a and the hyperplane B perpendicular to b . They must intersect along a plane α^* passing through P . Because all the lines of α^* are perpendicular to all the lines of α , the plane α^* is defined as the absolutely perpendicular plane to α .

α and α^* do not belong to the same hyperplane.

Definition II. A hyperplane A is perpendicular to a plane α when it contains the plane α^* absolutely perpendicular to α .

Each plane of A which passes through the line of intersection between α and A is perpendicular to α .

Theorem VII. Two perpendicular planes belonging to a same hyperplane and their absolutely perpendicular planes determine four concurrent non-coplanar lines perpendicular to one another.

Let α and β be two planes belonging to the hyperplane Φ (Figure 19). Inside it they are perpendicular to each other in the sense of the solid geometry.

Through any point R of the line r common to α and β draw the absolutely perpendicular planes α^* and β^* of α and β . They must belong to the hyperplane A perpendicular to r at R , therefore, they intersect along a line r^* . Through R draw the line a of α and the line b of β , both perpendicular to r . Because of this perpendicularity a belongs to β^* and b to α^* . It follows that $\alpha, \beta,$

4

important

books

in the field

from...

Barnes & Noble

1. Engineering Descriptive Geometry

78 Examples with Complete Solutions. 139 Problems including Answers or Suggestions. Diagrams Drawn to Scale on Cross-Section Paper.

by *Steve M. Slaby*. "The style is simple and uncomplicated. It is geared to the needs of the average college student and is well organized. Drawings are unusually clear, uncluttered, and admirable in every way. . . It would make a welcome addition to the shelves of the high school teacher of solid geometry."--*Mathematics Teacher*

"Presenting the basic principles of descriptive geometry in clear, annotated pictorial representations followed by graphic examples."--*Science News Letter*

Paperback \$2.50

2. Engineering Drawing

Basic Principles and Rules with Problems & Tables
ASA Standard Drawings & Drafting Room Practice

by *Lombardo, Johnson, Short and Lombardo*. "The purpose of this text is to provide a comprehensive, practical guide that will aid the student to master the essentials of engineering drawing. The text is designed to introduce him to develop working skill and efficiency."--*Design News*

"Should prove useful not only to the student, but also to the engineer wishing to refresh his memory on a particular point."--*Engineering Journal*

Paperback \$2.50

3. Technical Writing

A Guide to Manuals, Reports, Proposals, Articles, etc., in Industry & the Government

by *Richard W. Smith*. Written for the embryo technical writer with heavy emphasis placed on the industrial aspects of the subject giving broad application to the engineering field. It includes -- useful chapters on "The Mechanics of the Trade," a comprehensive bibliography; an appendix entitled "Are You Ready to Write" offering review examination that covers basic grammar rules and skill in expository writing, with answers and explanations.

"It's an excellent summary of the whole field, which includes many areas of technical writing that most books neglect."--*James Stokley, Michigan State University*

Cloth \$3.50; Paperback \$1.25

4. Thinking With a Pencil

With 692 Illustrations Showing Easy Ways to Make and Use Drawings in Your Work and in Your Hobbies

by *Henning Nelms*. This work begins with drawings which are so simple that they require no skill at all. Each chapter prepares the reader for the next and at the same time provides an effortless review of the material already studied. The reader learns to draw by making drawings that he can use. The formal practice required by other approaches to drawing is almost entirely eliminated.

"In my opinion your book would definitely be a valuable addition to any engineering student's library. Any medium which helps an engineer to convey his ideas to another person is without question a vital and necessary part of an engineer's education."--*Steve M. Slaby, Princeton University*

Paperback \$1.95

Free examination copies of paperbacks are available to instructors

Barnes & Noble, Inc. 105 Fifth Avenue, New York 3, N.Y.

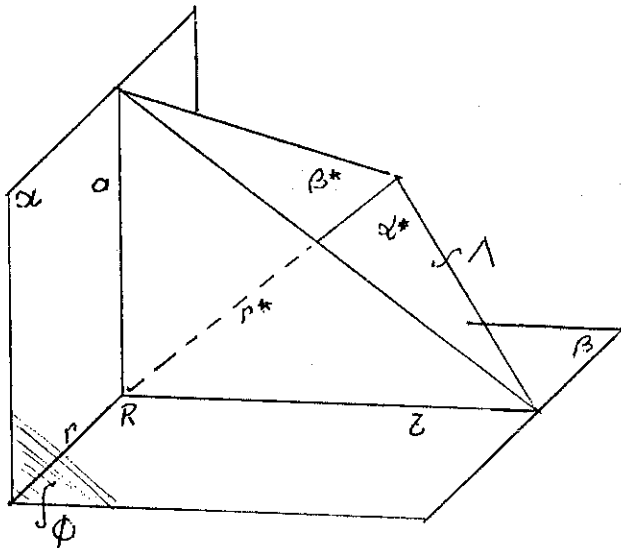

Figure 19

α^* , β^* intersect along the four lines a , b , r , r^* mutually perpendicular.

This theorem leads to the statement:

Through any point of the space of four dimensions pass four distinct non-coplanar lines perpendicular to one another.

Definition III. The angle between two planes α , β , not belonging to the same hyperplane, is the angle whose sides are the lines of intersection between α , β and a plane perpendicular to both of them (Figure 20).

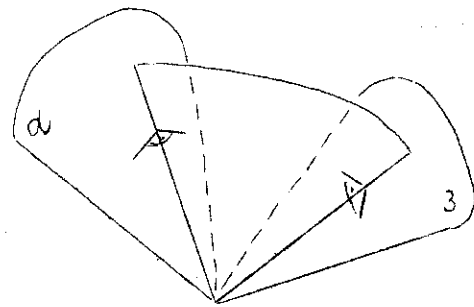

Figure 20

Theorem VIII. Given two planes not belonging to the same hyperplane there are "two" planes simultaneously perpendicular to them. (Figure 21).

Let α and β be the given planes intersecting at the point O and r be any line of α not passing through O . Each point of r connected to determine a hyperplane inside which only one perpendicular to β can be dropped from the given point.

This perpendicular and all the other ones dropped through the points of r determine a hyperplane that intersect β along a line s .

The same construction applied to the points of s and the perpendiculars to α through them leads to a line r_1 of α that does not coincide with r .

Relating the points A, B, \dots of r to the points A_1, B_1 of r_1 by means of a projectivity can be proved that there must be two segments such as RR_1 . Therefore there are two planes perpendicular to α and β .

For the sake of shortness, the proof of the projectivity is omitted.

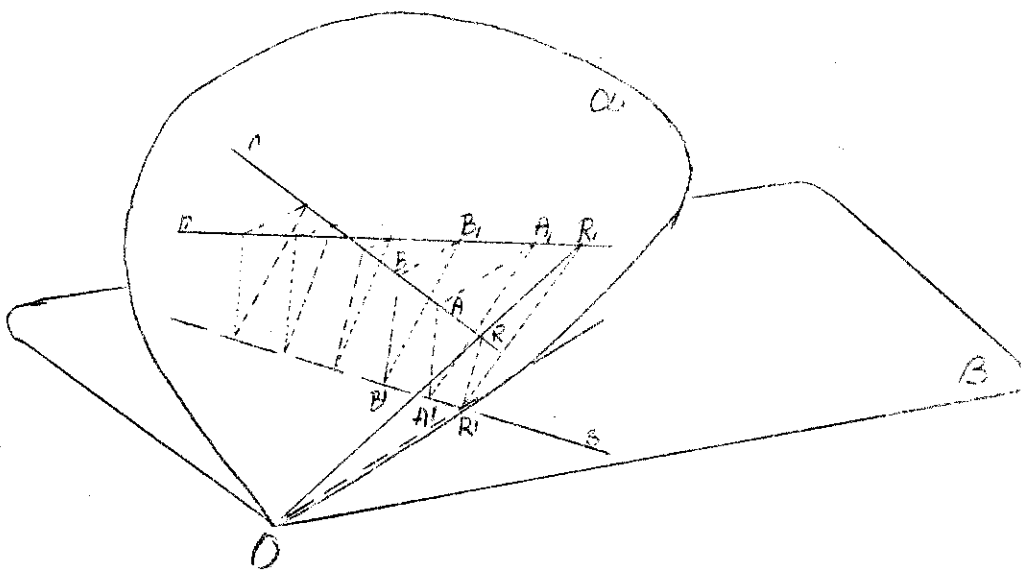
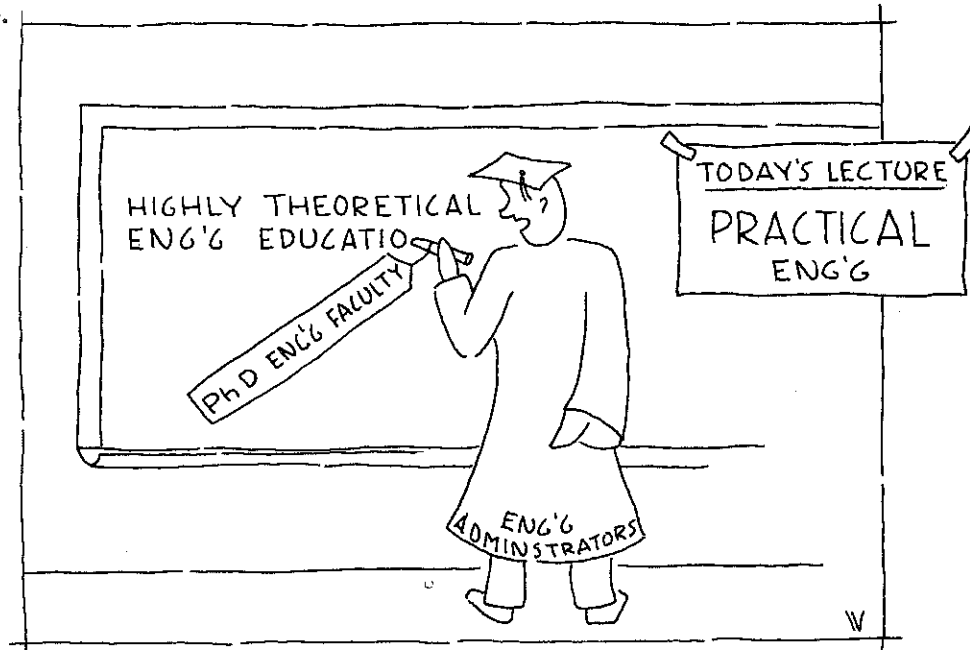

Figure 21



"HOW STRANGE - THIS ORANGE CHALK ALWAYS MAKES ORANGE LETTERS."

Cartoon Contributed by Ernest R. Weidhaas,
 Pennsylvania State University.

the most efficient and successful method of invention and design, -- thinking with a pencil. It is the same time-tested method used in the famous notebooks of Leonardo da Vinci (1452-1519), who was a leading engineer as well as a great painter.

When the inventor's first sketch is examined, it usually reveals mistakes to be corrected, and it shows where to make improvements in the initial plan. Often a series of sketches may be needed to develop an idea, including functional sketches to show a principle of operation, flow sheets if successive steps in a process are involved, feasibility sketches to verify the validity of a method, and a layout sketch to check the relation of components, all of which are helpful in refining the idea to make sure that it will accomplish its purpose. Invention is frequently part of a design project or the goal of organized research. Then it may involve the joint efforts of several persons working together as a team in a deliberate search for better products or methods, and frequent communication among associates requires the constant use of graphs and sketches.

There is currently much concern about the proper teaching of design in our engineering colleges. It is said that design is the application of scientific principles to the synthesis of a system, which is a sophisticated approach. From an engineering point of view, design is the ingenious development of an original or existing project which is conceived, perfected, and defined for physical realization with the aid of graphics, technical knowledge, and good judgment based on experience. It requires originality, ingenuity, resourcefulness, and complete understanding of the entire design project. These essential capa-

bilities cannot be taken for granted. Unless engineering students are properly prepared for the design function during their first two years in college, departmental design courses at the junior and senior level will not be successful. The updated engineering graphics course, which is design-oriented and enriched by new material from current technological developments, provides the most helpful introduction to engineering design.

After students have learned how to use graphics for communication and for problem solving, they welcome the opportunity to develop their creative talents which is afforded by simple open-end problems in conceptual design. The first requirements are complete understanding of the entire project and realization that several satisfactory designs are possible, due to the influence of such factors as materials used, methods of manufacture, cost, weight, and space limitations. The stimulating challenge to create something new and useful, to take the initiative on their own responsibility, to make the right decisions based on their limited experience and all the pertinent information they can find, and to work out independently a design to be proud of, gives students strong motivation for the diligent study of engineering.

Productive research now plays an important role in engineering education, and faculty members who are actively engaged in research projects give seminars describing their technological achievements. Unfortunately, when freshmen and sophomores attend research seminars in which they are interested, the sophisticated language employed is usually over their heads. However, the graphics instructor can arrange informal visits to research laboratories for small groups of students having

special interests, and satisfactory explanations can then be given where the research is in progress. Here is a rich source of new material for conceptual design problems. These contacts also provide good opportunities for useful cooperation between research and graphics personnel, because graphics has many helpful applications in research.

One of the most useful tools in productive research is the visual interpretation of experimental data by means of graphs. When tests are conducted to determine the behavior or performance of variables under differing conditions, the resulting data are plotted and curves are drawn to show clearly the response, trends, and growth. Then these curves are used as the reliable basis for studies in depth to derive empirical equations which define the true relationship of the variables, whether it conforms to a standard pattern or not. The graphs also provide data for graphic analysis and for computation by nomographs, calculating charts, and graphical calculus.

Graphic analysis is the systematic visual investigation of physical relationships by means of graphs, vectors, diagrams, and geometric constructions, to interpret their true meaning and to solve problems involving them. Every engineering student should be given an adequate introduction to graphic analysis, including actual experience in using it to solve design problems within his grasp. This experience will help to develop graphic intuition, which is the ready ability to apply the graphic solution best suited to the task at hand. The ability to use graphics to advantage has been demonstrated by many engineers, designers, and

researchers who have benefited from graphic analysis, devised useful graphic solutions, and published articles in the technical journals explaining these solutions. The new reading guide, *Graphic Solutions of Technical Problems*, a bibliography with abstracts, which is now available in engineering college and public libraries, is an invitation to read technical literature describing graphic procedures in a wide range of useful applications. It illustrates by many examples that there are opportunities for graphics instructors to reach out into the unknown and apply their talents to the solution of challenging problems in new fields, such as laser optics and orbital transfer in space flight. This experience will enrich their graphics courses.

The versatility of graphics enhances the value of its contribution to engineering education. The expanding scope of useful applications of graphics in a wide spectrum from computers to jet propulsion accelerates the growth of visual thinking to keep pace with the development of new forms of graphic expression. We need a more comprehensive definition of graphics that mentions some of its important functions, including its aid to teaching and learning. Accordingly, engineering graphics is the expression of visual thinking by means of views, graphs, and diagrams for the purpose of communicating and interpreting technical knowledge; for use in design, analysis, and computation; and for enlightenment to make study meaningful.

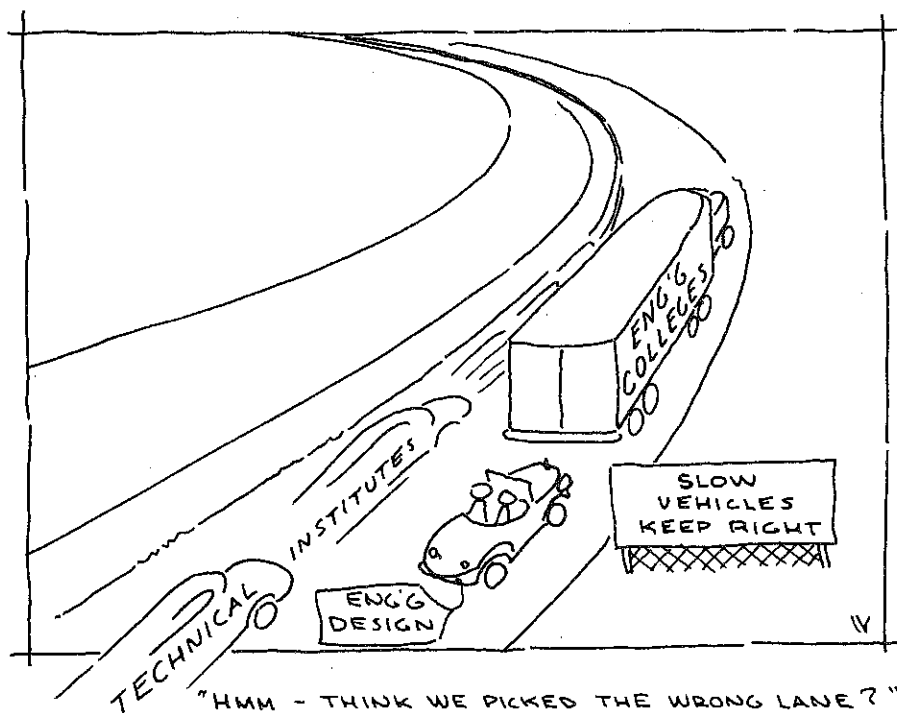

Cartoon Contributed by Ernest R. Weidhaas,
Pennsylvania State University.

THE NEW Ames Lettering Guide...

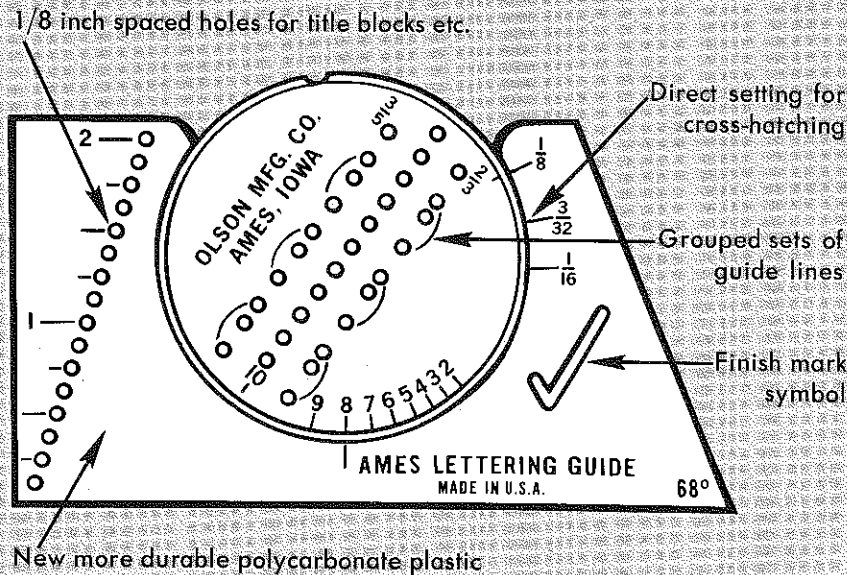

**NOW WITH
SEVERAL
ADDED
FEATURES**

We would be happy to send a free new Ames Lettering Guide to any instructor. Write us on your departmental letterhead and it will be forwarded immediately. After trial and evaluation, we feel sure you will recommend it to your students.

OLSON MANUFACTURING CO.
P.O. Box 109 • Ames, Iowa
"Drafting Products by Olson of Ames"

Available through jobbers, distributors and dealers of drafting equipment everywhere.

INFORMATION FOR AUTHORS

Manuscripts. Articles or papers may be descriptive, theoretical, documentary, tutorial in nature, or they may be reviews. Editorial considerations suggest most papers should be 2000 to 4500 words in length. The topic should receive professional treatment in depth. One or two copies of the manuscript should be submitted. Articles should be typewritten and double spaced with typing only on one side of each sheet. Pages should be numbered to avoid omissions. References, footnotes and illustrations should be listed on separate sheets and not inserted within the text.

Illustrations. Line drawings may be prepared in pencil or India ink with mechanical lettering. If mechanical lettering is not available, freehand lettering should be placed on a separate overlay sheet. Photocopies (same size or reduced) of the original line drawings are accepted if they are clean, clear and sharp in contrast. Illustration width limitations are (1) single column, 4-1/8 inch, and (2) double column, 9 inches. Height limitation is 11-3/4 inches for either column width. When illustrations are reduced 20 per cent, all lettering must be large enough to remain clear and legible. Photographs should be 8 x 10 glossy prints. Figure numbers and captions should be listed on a separate sheet. If there could be any

doubt about the positioning of the illustration, identify its top with a blue pencilled note in the margin. Figure numbers should be lightly written on the back of each illustration. If the illustration is prepared on translucent material, a blue pencilled note might be made in the lower margin on the face of the illustration.

Correspondence. Your candid observations via brief communications are welcomed. Your observations; criticism of, or comments on, previously published articles; or other timely notices of interest to the members of the Engineering Graphics Division are welcomed. Please indicate whether submitted correspondence may be published.

Writing Style. Spelling and capitalization should follow Webster's Seventh New Collegiate Dictionary, which also offers guidance in punctuation. For more detailed information of the editorial style, see United States Government Printing Office Style Manual, 1959.

If you have further questions -- write to the Editor.

Earl D. Black, Editor
The Journal of Engineering Graphics
General Motors Institute
Flint, Michigan 48502

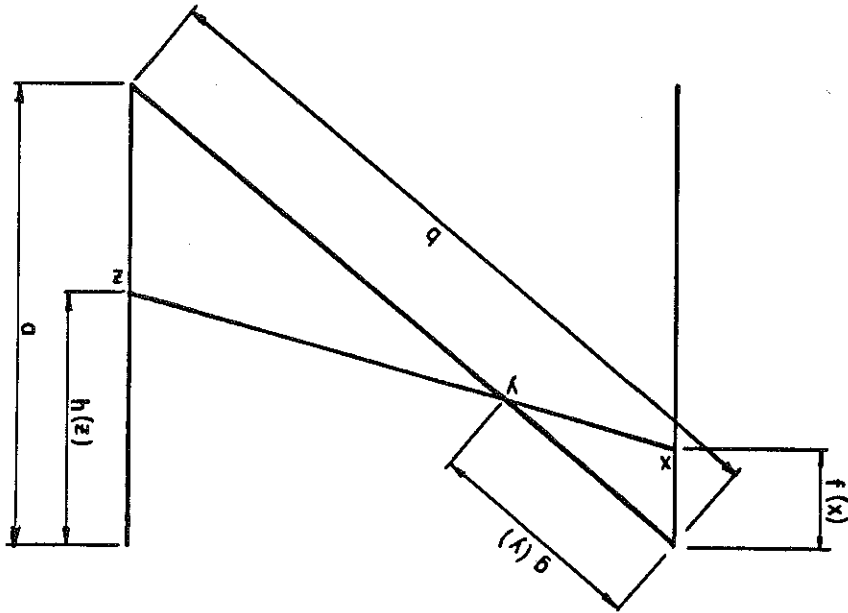

Figure 6

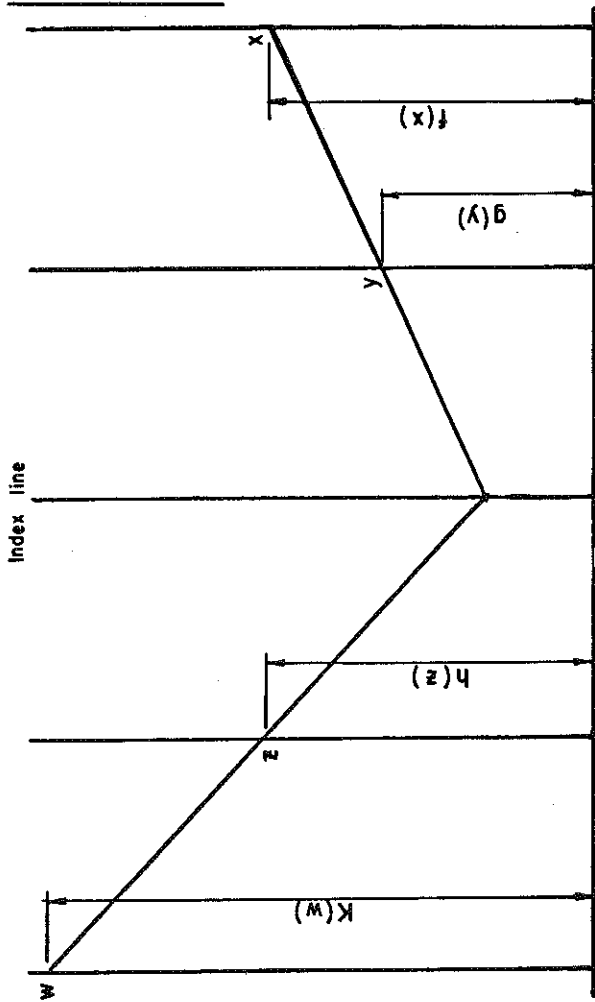

Figure 4

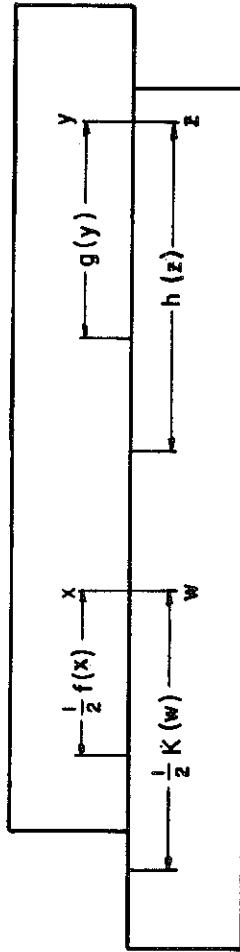

Figure 5

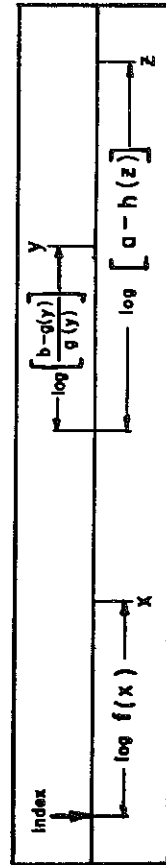

Figure 7

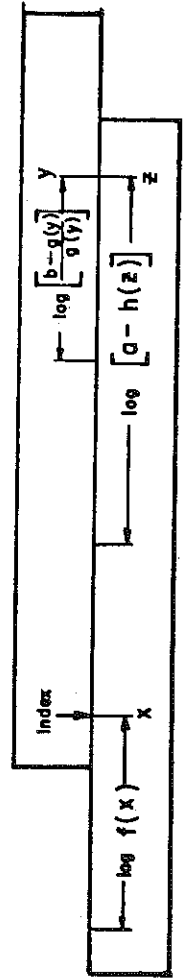
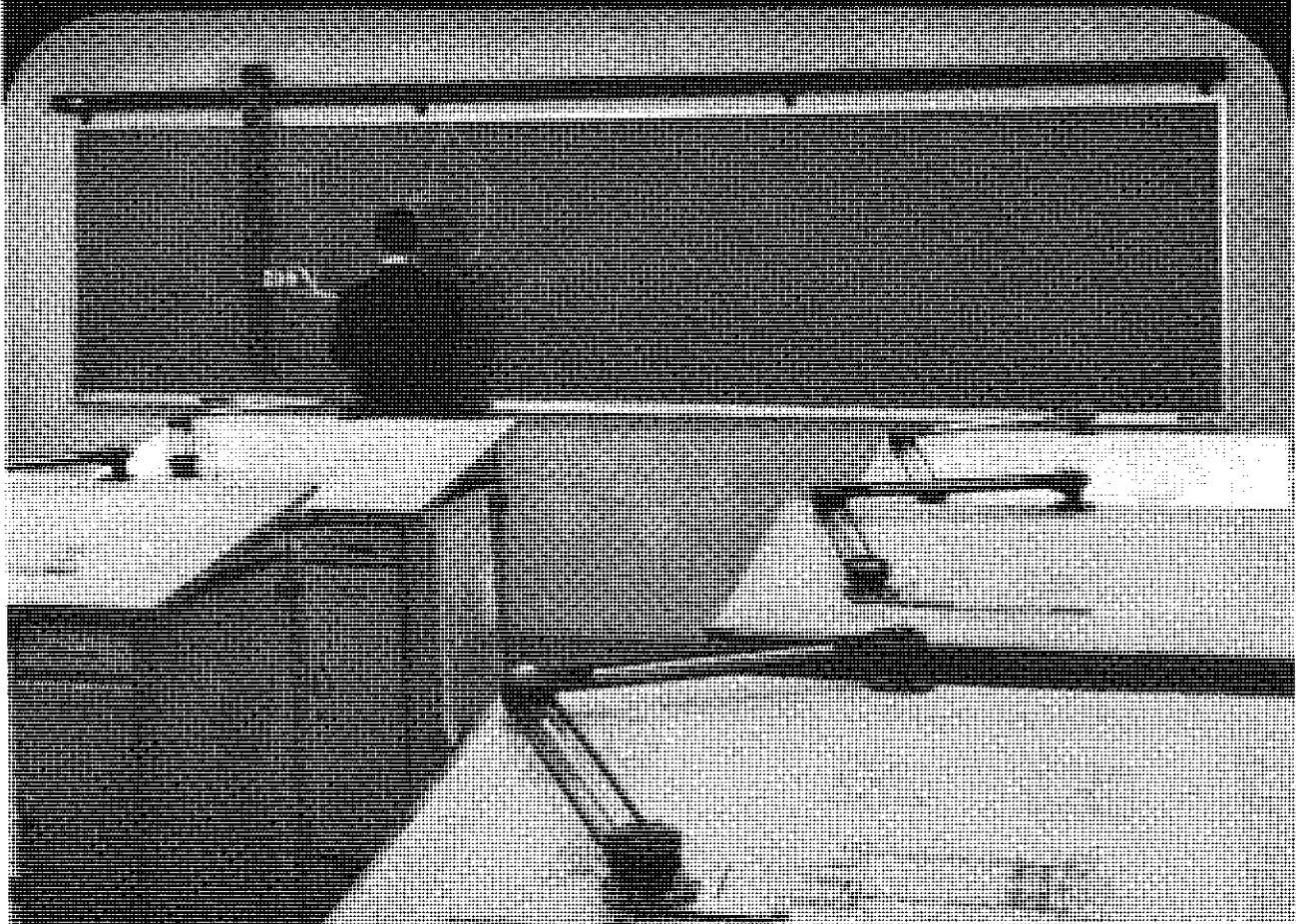

Figure 8

VEMCO'S MATCHED SET

for easier drafting instruction



V-TRACK Drafting Machine with Chalkboard Adapter for the Instructor. At the tables, Model 3300 Drafting Machine, with either 16", 18" or 20" arms, special disc brake, and automatic 15° indexing, for students.

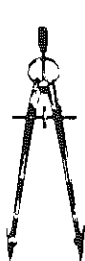

Add VEMCO American-made all steel Instruments, guaranteed without time limit ... compasses, dividers, ruling pens, scales... for a completely equipped classroom in drafting technique. Generous discounts on school orders.

*Write for catalogs on V-Track;
Model 3300; Instruments.*

V. & E. MANUFACTURING CO.

766 S. Fair Oaks Ave. / Pasadena, Calif.



WEIDHAAS DEAN AT PENN STATE

Ernest R. Weidhaas, former head of the Division of Engineering Graphics at the Pennsylvania State University, has been appointed Assistant Dean for Commonwealth Campuses in the College of Engineering at Penn State. In this new position, he will be responsible for the programs in engineering technology offered at nineteen campuses throughout Pennsylvania. He will also continue as head of the Department of General Engineering and Professor of Engineering Graphics.

Dean Weidhaas has been an active member of the Engineering Graphics Division of ASEE since 1950 and served on the Board of Directors since 1961.



REPORT OF AWARDS COMMITTEE

The Awards Committee has prepared proposals to be submitted to the Awards Policy Committee, ASEE for two new awards. The awards are to be known as THE KREIDLER AWARD FOR GRAPHICS RESEARCH and THE FRANK OPPENHEIMER AWARD.

THE KREIDLER AWARD FOR GRAPHICS RESEARCH is intended to encourage both research in graphics and the use of graphics in research. The term "graphics research" is to be interpreted in the broadest possible sense. Any article, paper, report or thesis concerning graphics research in any way may compete. The award is to consist of \$100 plus an appropriate certificate and is to be awarded at the Mid-Year Meeting of the Division.

THE FRANK OPPENHEIMER AWARD is intended to encourage excellence in presentation of papers at meetings of the Division. The award is to consist of \$100 plus an appropriate certificate and is to be awarded twice yearly, once at the Mid-Year Meeting and once at the Annual Meeting. Speakers will be judged on familiarity with content, timing, delivery, enthusiasm and effective use of visual aids (if used). The judges appointed by the Awards Committee may recommend that the award be shared, or that it not be given, at a particular meeting.

The Awards Committee will continue to seek additional funds for awards and to determine the kinds and amounts of awards to be given.

Albert L. Hoag
Chairman
Awards Committee



Nothing is so powerful as an idea whose time has come.

projection and application to the solutions of 3-D problems has improved 40 per cent since the introduction of the thought model method.

3. The use of T.V. has a sobering effect upon the instructor. He has an opportunity to see what he looks like to his students. Whether or not you plan to use T.V. in your teaching, I would strongly urge you to try a few T.V. lectures in a studio setting. I am confident that you will learn a good deal about your performance.
4. The instructors who cooperated in our studies have reported the effectiveness of the thought model method in the significant improvement of visualization ability of their students. Five schools were included in the experiment.
5. Any instructor can easily learn the use of the thought model method. You should have fun doing it.

And finally, I will be glad to cooperate with anyone who wishes to use some of the material we have available. I believe arrangements can be made to use video tapes or kinescoped film of the tapes. At present, we have 12 lectures on video tape. Films of other lectures will be made if we receive a reasonable number of requests.

SELECTED REFERENCES

1. "The Creative Person," proceedings of the conference, October 13-17, 1961, Alumni Center, Lake Tahoe, California. (Available from University Extension, University of California, Berkeley, California.)
2. "The highly effective Individual," by Donald W. MacKinnon, Director, Institute of Personality Assessment and Research, University of California, Berkeley, California, Teachers College Record, Vol. 61, No. 7, April, 1960.
3. "The Nature and Nurture of Creative Talent," by Donald W. MacKinnon, Walter Van Dyke Bingham Lecture given at Yale University, New Haven, Connecticut, April 11, 1962.
4. "Identifying the Creative Man," by Harrison G. Gough, Associate Director, Institute of Personality Assessment and Research, University of California, Berkeley, California, The Journal of Value Engineering, Vol. 2, No. 4, August 15, 1965, pp. 5-12.
5. "Fostering Creativity in Students of Engineering," by Donald W. MacKinnon, Journal of Engineering Education, Vol. 52, No. 3, December, 1961.
6. "Testing for Creativity," by Eugene Raudsepp, Machine Design, Vol. 37, May, 27, 1965, pp. 106-112.



Engineers can go "nuts" without the "bolts."

*Reflecting the need for a broader
understanding of a powerful design tool*

ENGINEERING GRAPHICS

For Design and Analysis

ROBERT H. HAMMOND, *United States Military Academy*
CARSON P. BUCK, *Syracuse University*
WILLIAM B. ROGERS, *United States Military Academy*
GERALD W. WALSH, Jr., *Jefferson Community College*
HUGH P. ACKERT, *University of Notre Dame*

THIS CLASS-TESTED TEXT BOOK reflects the growing need for a broad comprehension of graphics as a powerful tool in the design process. Its prime purpose is to provide the student with a complete understanding of the role the graphic language plays in the conception, analysis, and communication of ideas. At the same time, the book presents sufficient material to enable the student to understand basic production drawings and to provide the background for the understanding of more complex drawings.

Emphasis is on the theory of projection and on analysis rather than on the techniques and skills required in preparing a production drawing. The development of skill is emphasized as it affects the concepts of accuracy in the use of graphics for analysis. Spatial relationships required for the analysis of three-dimensional problems are presented so that the student can develop his own solution for any particular problem. Numerous step-by-step illustrations supplement the text, and no concept is applied until its theory has been developed for the general case.

A wide range of student problems offer abundant exercises in both representation and analysis. 1964. 534 pp., illus. \$9.50

PROBLEMS — Engineering Graphics For Design And Analysis

Designed for use with ENGINEERING GRAPHICS, this manual provides a full range of graphics problems adaptable to meet most course requirements. The 118 problems are graduated according to difficulty, within five parts, beginning with simple concepts and progressing to those more thought provoking.

1965. 397 pp. \$4.50

The Ronald Press Company.....

..... 15 East 26th Street / New York, N.Y.

The Summer Drafting Institute, Cont.

their pencil line drawings. This was done so the students could observe the reproductive quality of their line work. They assumed a very favorable attitude toward this requirement and were quite obviously motivated to improve their line quality.

LESSON ASSIGNMENT SHEET FIFTY-ONE

1. PERIOD: V14B.
2. SUBJECT: Vectors.
3. OBJECTIVES: To relate vector graphics to shop math.
4. ASSIGNMENT: Graphically analyze the saw-tooth truss shown below to determine the magnitude and nature -- compression (C) or tension (T) -- of the loads in members BJ, JK, KL, MI, MN, and NO.
5. COMMENTS: Use Bow's notation and a Maxwell diagram.
6. LETTERING: 1/8" inclined capitals and lower case.
7. REFERENCES: Class notes.
8. EST. TIME: 1-1/2 hours.
9. DUE: 7:00 a.m. July 16, 1965.

Figure 2 A TYPICAL LESSON ASSIGNMENT SHEET

Virtually, all assignments submitted by the students were scored by a member of the Engineering Graphics staff. A scale of 0 through 10 was used for the evaluation with 10 being the perfect score. These scores were averaged at the end of each week to obtain an overall estimate of the students' performance on the week's assignments.

Once each week, usually on Friday afternoon, a short but comprehensive examination was given to the students. The scores earned on these tests were weighted equally with the averages earned on assignments completed throughout the same week. This combined score constituted a student's weekly grade.

All students were individually counseled during the fourth, seventh, and tenth weeks. During these sessions, each student was told what his average was and was advised of those techniques which he should especially strive to improve. Lettering and line quality were most frequently mentioned for improvement.

A grand average for each student was deter-

mined at the end of the twelfth week, and certificates of satisfactory completion were appropriately awarded. Any student having a final average of 70 or more was given the certificate. If, however, a student's average was less than 70, his certification was carefully considered. Here the three instructors were given rather broad latitude in judging a student's fitness. If the student had displayed a consistently positive attitude toward the course, he was favorably considered. If, on the other hand, his record showed excessive absences, or he was lax in regard to the prompt submission of assignments, or his general deportment in or out of class was judged to be less than acceptable, certification was withheld.

The certificate itself was 8-1/2" x 11" and simply stated that a certain student had successfully completed 360 hours of structural drafting. Figure 4 shows the certificate as it was signed by the three members of the co-sponsoring agencies.

To judge the overall effectiveness of the drafting institute would be virtually impossible at this time. There are, however, some indications of its worth.

One such indication might be noted in the response shown by prospective employers. After writing letters of inquiry to a Dallas firm, four students were interviewed for drafting positions. An official of a Texas foundry and machine company, after hearing of the program, contacted the placement office at Texas A&M to set a date for interviewing prospective draftsmen from the institute. A representative of an engineering consulting agency in Houston wrote to say his company would interview "any of your graduates if they are interested in our firm." Other similar instances could be cited, but these should be sufficient to indicate the favorable attitude shown by certain industrial firms.

By way of conclusion it might be said that there is every indication that more courses of this nature should be offered. These vocational classes should not, of course, be limited to drafting, but should branch out into such areas as welding, piping, automotive mechanics, and electronics. These courses should be as thorough as possible and should go as deeply into the subject as the students' ability will permit. These tasks will not be easy. With the constantly changing technology we are privileged to witness today, the vocational teacher will find it rather difficult to "dig out", assimilate, and teach subject matter which is new or foreign to him. The task, however, must be completed if the obligation of training mechanics, draftsmen, and technicians is to be fulfilled.



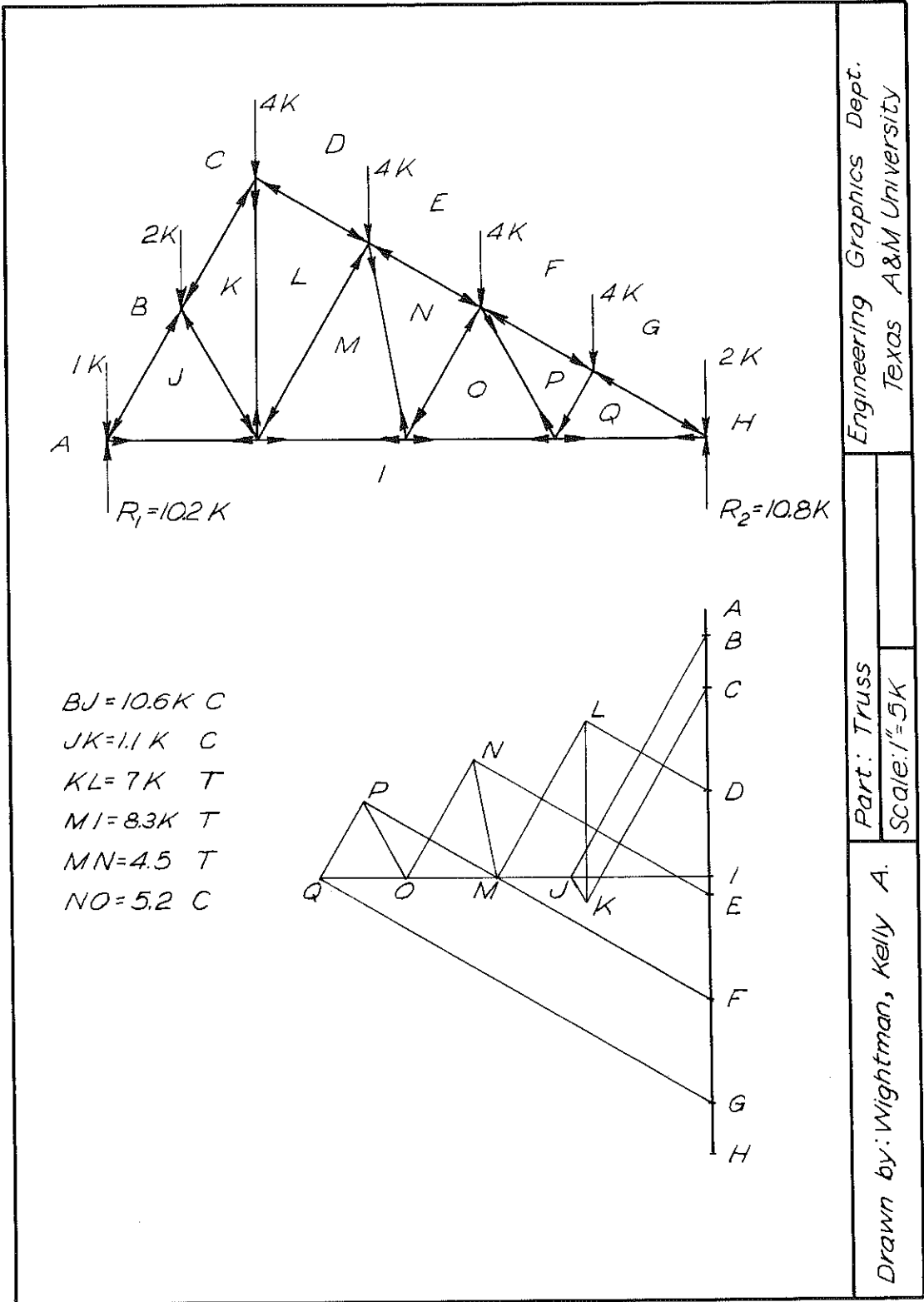

Figure 3 THE COMPLETED ASSIGNMENT

The Engineering Graphics Department

AND

The Engineering Extension Service

OF

Texas A&M University

CERTIFY THAT

JOHN L. DOUGH

HAS SATISFACTORILY COMPLETED 360 HOURS

OF

Structural Drafting

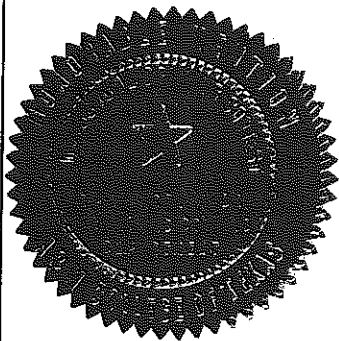

AUGUST 27, 1965

Charles R. Cozens
INSTRUCTOR, ENGINEERING GRAPHICS DEPARTMENT
H. D. Bearden
DIRECTOR, ENGINEERING EXTENSION SERVICE
W. E. Street
HEAD, ENGINEERING GRAPHICS DEPARTMENT

THE CERTIFICATE GIVEN TO THE STUDENTS
WHO SUCCESSFULLY COMPLETED THE COURSE

Figure 4



WITICISMS

Man is not born free. He is born helpless and must earn his freedom as an individual through the medium of culture and knowledge.



Improvement in American education has been by refinement, not by redefinition.



The more we know the easier it is to imagine how and where to learn more.



Teachers need an appropriate place in which to perform the professional quality in their job.



Only a devine being has perfect and complete knowledge.



Mr. Bruning's more expensive sepia paper pays off every day at 5!

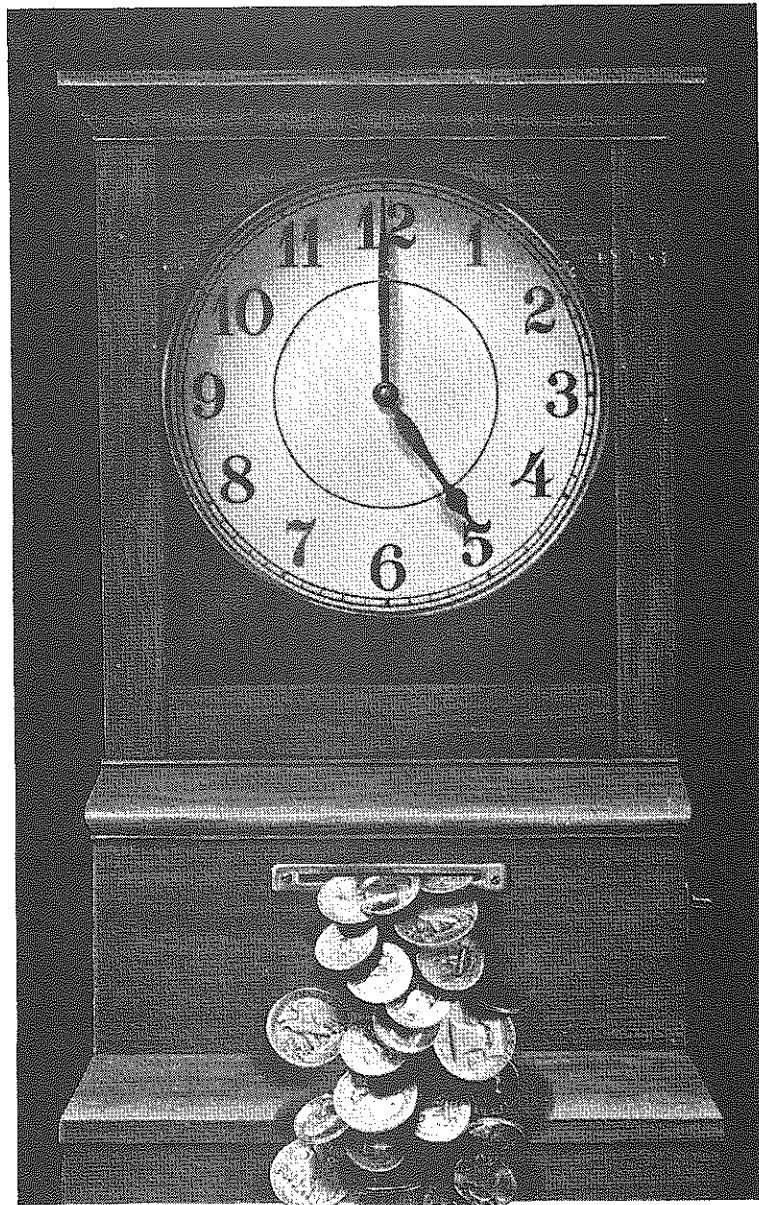

Why? Because it's from 28 to 52 percent faster than any other paper you can use.

And faster sepias pay off in three ways:

1. Faster papers mean less operator time at the machine.
2. Faster papers mean increased production.
3. Faster papers give your operators much greater latitude in operating conditions to produce perfect prints. Wastage takes a nosedive.

Because Mr. Bruning's new sepia paper is so much faster, your operator can often switch from making blue-line prints to sepias without having to adjust machine speed.

What else do you get? Superior drafting and eradication qualities. If you haven't tried Mr. Bruning's faster sepia, you'll be surprised at its ability to take pencil or ink revisions—and then maintain high legibility through various generations of prints.

Are we knocking our less costly sepia? Not one bit. It's a top-quality paper in its own right—just not as fast. Moral: people interested in profits buy value, not just price.

The Bruning man will stand behind everything we've said. Make him prove it—with a demonstration in your own shop. Give him a call. By now, you probably even know his home phone number.

 **Bruning**
DIVISION OF
ADDRESSOGRAPH MULTIGRAPH CORP

Stimulating Engineering Graphics Texts from McGraw-Hill

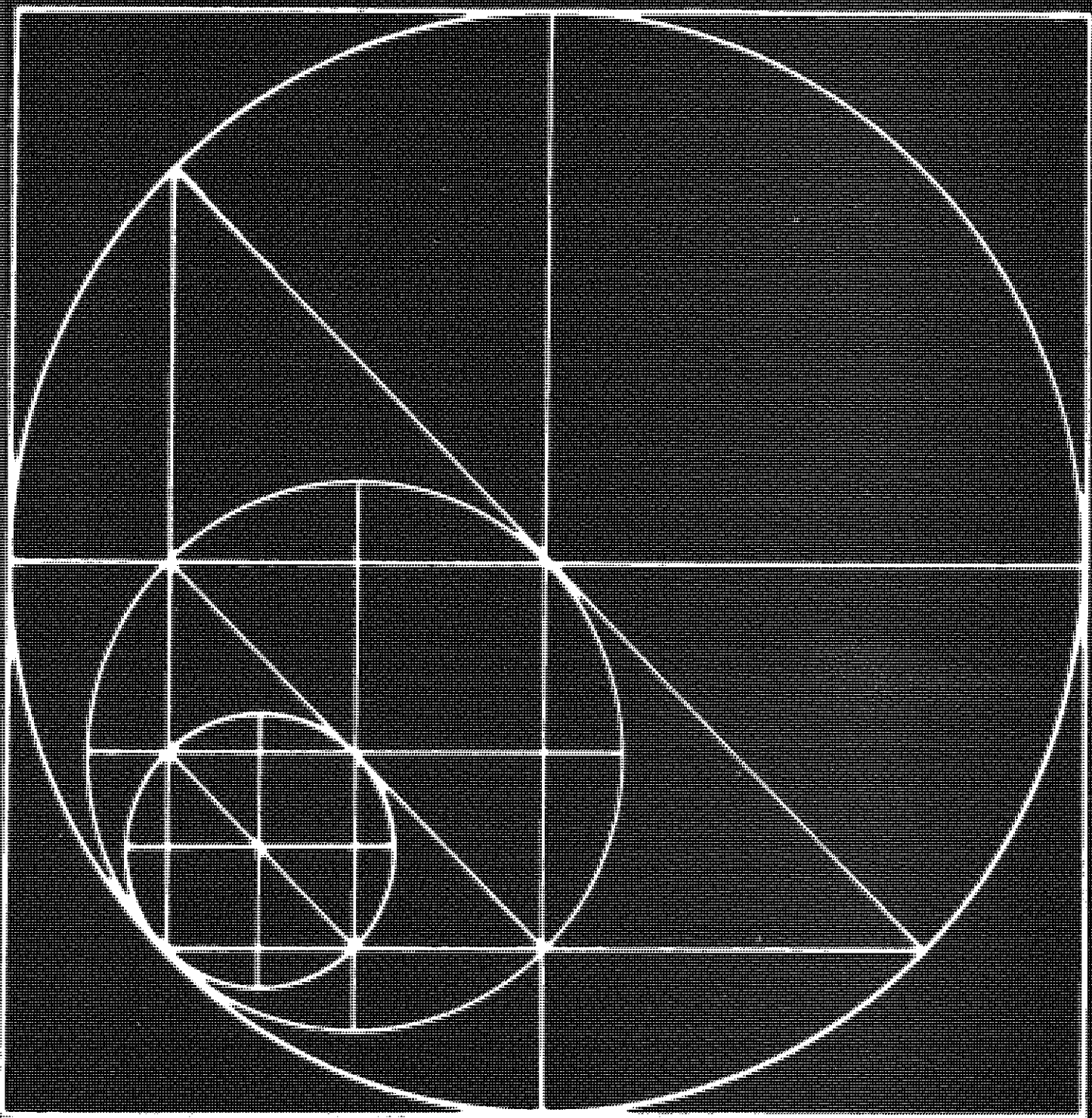

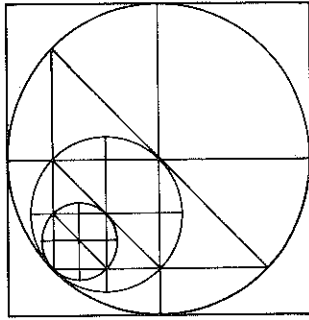

A MANUAL OF ENGINEERING DRAWING FOR STUDENTS AND DRAFTSMEN, Tenth Edition

By **THOMAS E. FRENCH**, The Ohio State University; and **CHARLES J. VIERCK**, University of Florida. Off press.

In this tenth edition of the most successful engineering drawing book, color illustrations are used for the first time. Shades of red and brown make the book more readable, aid in three-dimensional visualization, and help to separate the important from the supportive. Six hundred new problems are included, many of them drawn from such diverse fields as medicine, oceanography, prosthetics, and basic research. A new chapter, The Fundamentals of Design, defines design . . . gives insight into the design mentality . . . delineates procedures-materials selection, proportioning, construction, and manufacture . . . introduces some aesthetic considerations.

FUNDAMENTALS OF ENGINEERING DRAWING, Second Edition

By **THOMAS E. FRENCH** and **CHARLES J. VIERCK**. Off press.

Designed for the freshman course, this fundamentals text consists of the first thirteen chapters of **A MANUAL OF ENGINEERING DRAWING FOR STUDENTS AND DRAFTSMEN, Tenth Edition**.

SUPPLEMENTARY MATERIALS AVAILABLE: Engineering Drawing Problems (for use with Tenth Edition); Fundamental Engineering Problems for use with Fundamentals text, Second Edition); Teacher's Manual (for use with both texts).

INTRODUCTION TO GRAPHICAL ANALYSIS AND DESIGN

By **E. LEIGHTON WELLMAN**, Worcester Polytechnic Institute. Ready for Fall classes.

This modern engineering drawing text, written by a leading scholar-teacher, is designed for the one-semester course or the first half of the two-semester course. Throughout the book, freehand drawing is emphasized and applied to problem solutions whenever possible. In graphical analysis, the close correlation and remarkable equivalence of mathematical solutions is stressed.



Send for your examination copies today

McGraw-Hill Book Company • 330 West 42nd Street • New York, New York 10036

The reading and visualization of multiview drawing is thoroughly developed with logical and well-tested methods. The final chapters provide the basic elements for an introduction to engineering design. Each topic is fully illustrated, thoroughly explained, and demonstrated with examples. A large selection of problems follows each chapter.

ENGINEERING DRAWING PROBLEMS:

Series I, Second Edition

By **HIRAM E. GRANT**, Emeritus, Washington University. 64 pages, \$6.50.

This revision is a two-in-one workbook; two sets of problems of each type are printed on opposite sides of each workbook sheet so that the instructor can choose either one of the problems and have an alternate available for the following term.

PRACTICAL DESCRIPTIVE GEOMETRY, Second Edition

By **HIRAM E. GRANT**. 208 pages, \$6.95.

Here is a timely revision of this well-liked and widely used text for the standard one-semester descriptive geometry course. The applications have been obtained by the author's visits to hundreds of industrial plants.

CREATIVE PROBLEMS FOR BASIC ENGINEERING DRAWING, Alternate Edition

By **MATTHEW McNEARY** and **CLAUDE Z. WESTFALL**, both of University of Maine. 104 pages, \$5.95.

Introduces elementary design to the beginning student, stressing conceptual rather than analytical design. All problems are new. Drawings are made from verbal descriptions.

COMPUTER GRAPHICS IN COMMUNICATION

By **WILLIAM A. FETTER**, The Boeing Company. 128 pages, \$4.50, clothbound. Soft-cover Text Edition available for classroom adoption, \$2.50.

Designed to explain the increasingly important field of computer graphics — a technique for producing drawing, stereo views, and motion pictures by computer. Typical problems illustrate current applications, potential applications, and representative projects.

ROCKET PROBLEM

by

H. W. Blakeslee, Instructor
Technical Education Department

The center lines of the rocket are laid out so that isometric ellipse templates may be used on both top and front views. The rocket outline merely needs to be traced on the true-length center line and projected from there. The fins can be placed in any position so as to have two of them horizontal, frontal or in any other position. Recognition stripes can be added at the instructor's discretion.

Continued on Page 54

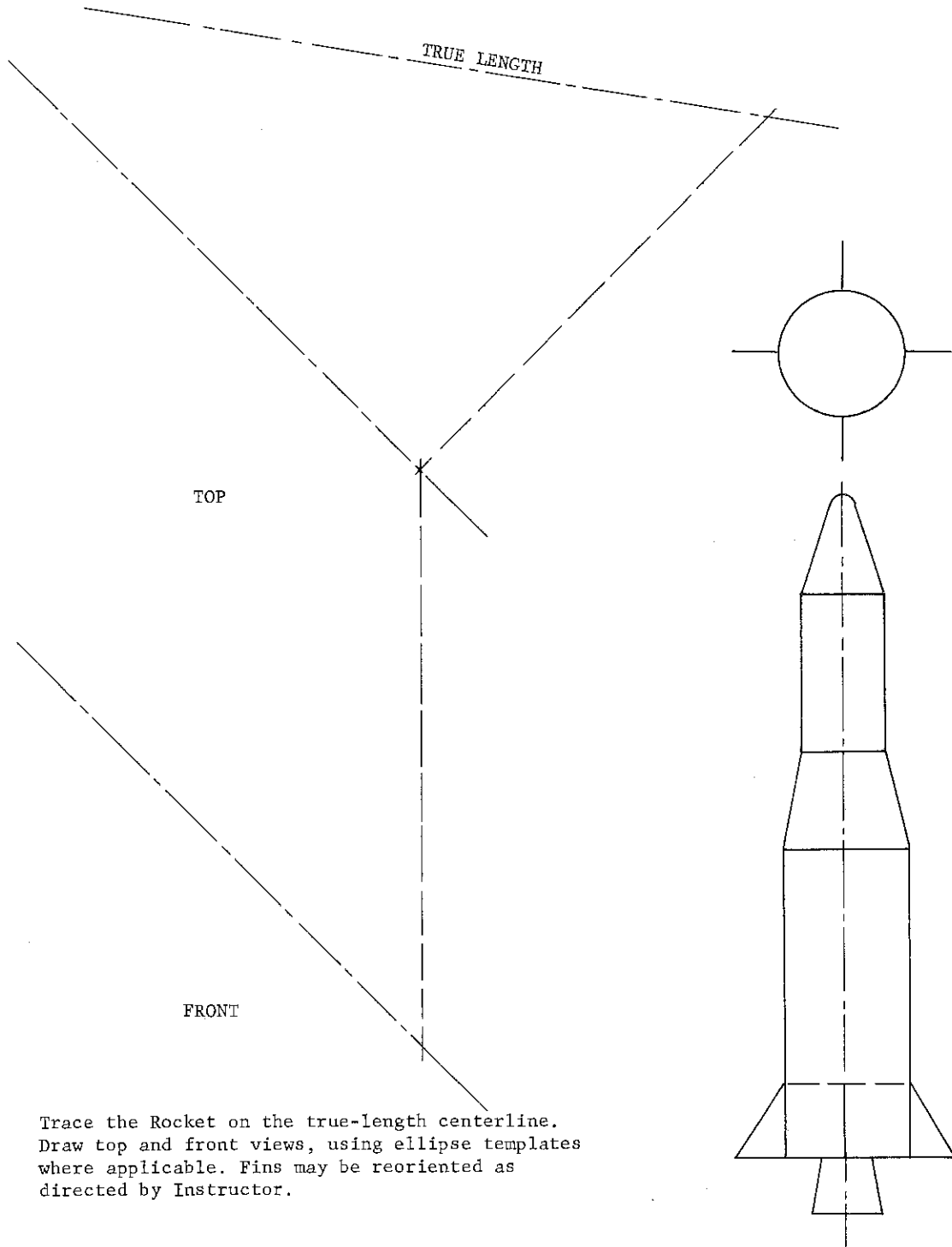

Trace the Rocket on the true-length centerline. Draw top and front views, using ellipse templates where applicable. Fins may be reoriented as directed by Instructor.

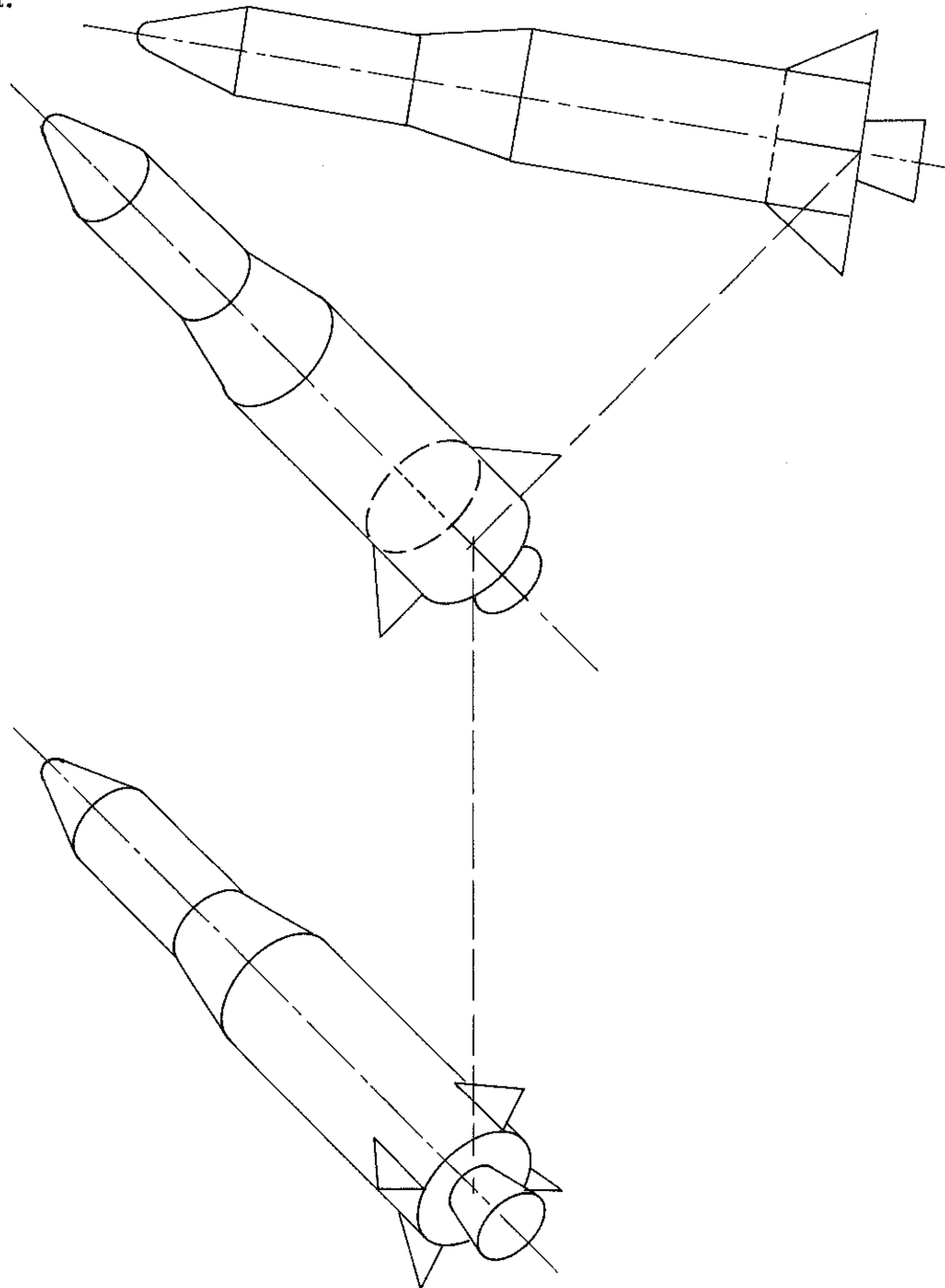

WITICISMS

For effective communication and understanding between two individuals, there must be a matching of knowledge and background.



Industry has the understanding of the major evil from which our whole educational system is suffering -- obsolescence.



Students should have opportunities to develop individual responsibility and skills in independent study.



There never was a time, nor will there be, when two men at one drafting board, or even three, could do as well as one man by himself or do the job half as well as it should be.



Automation of Design, Cont.

CONCLUSIONS. The present state of experimentation and development indicates a great future for the engineering designer. It is, therefore, apparent that the goal of the Engineering Graphics personnel is to see that their students have the basic principles of orthogonal and isometric projection and develop the ability to make clear sketches and drawings. Students should be made aware of the ever-expanding and changing technology in the field of engineering design, with

its resultant evolution in the types of drawings required, for the production of useful items for mankind.

Bibliography:

BIBLIOGRAPHY:

"Modern Engineering Design Practices" by Robert B. Norden - Chemical Engineering Magazine, August 2, 1965

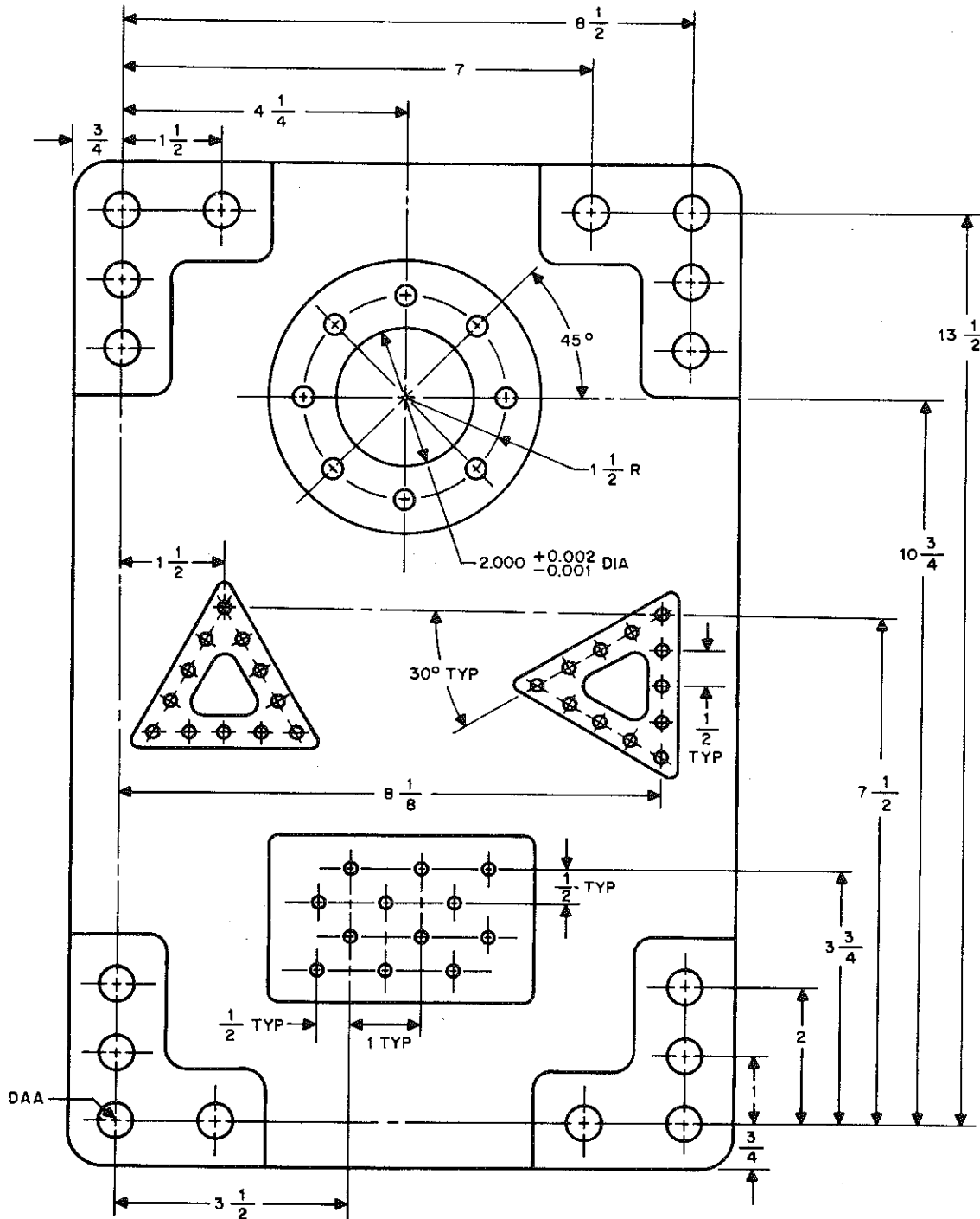

Fig. 3 Sample Part - Mounting Plate

Engineering Drawing

"Computer and Technical Documentation" by
D. O. Brending - Graphic Science Magazine,
May, 1964

"Engineering Models" by Dr. Robert P. Borri -
Graphic Science Magazine, May, 1965

"Ground Rules for Numerical Control, Dimensioning, and Tolerancing" by W. V. McGuire and C. S. Wolowicz - Graphic Science Magazine, May, 1965

"Better and Faster Design by Machine" by
Louis S. Gomolak - Electronics Magazine,
June 1, 1964

"Automated Drafting -- Where are We Now?" by
D. A. Curtiss - Graphic Science Magazine,
July, 1965

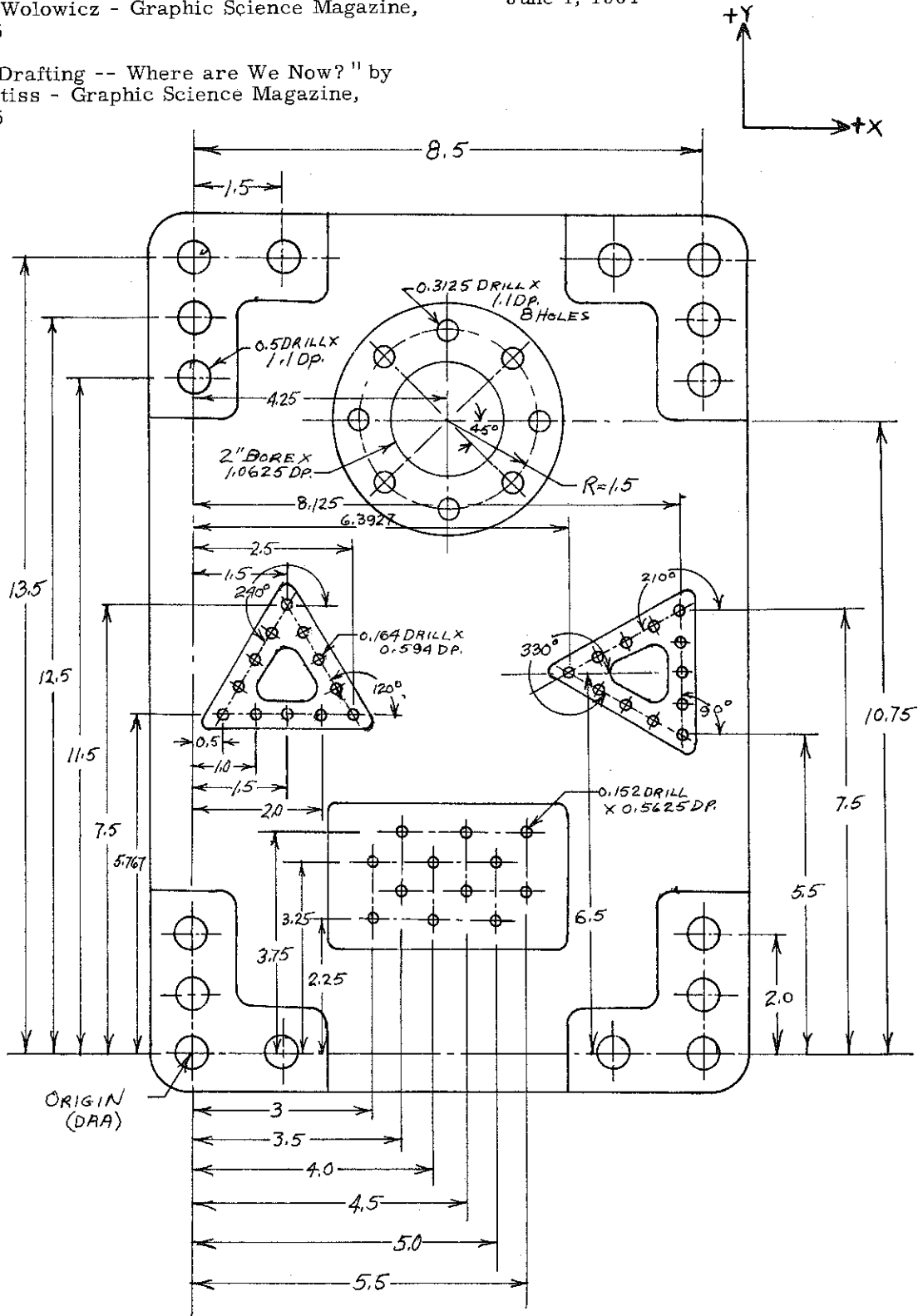

Fig. 4 Figure No. 3 Re-Dimensioned For Numerical Control Autospot

*An Integration of Engineering Drawing, Descriptive
Geometry, and Engineering Problems Solution ...*

**Engineering
Graphics,
Third Edition**

**James S. Rising
Maurice W. Almfeldt**

Iowa State University

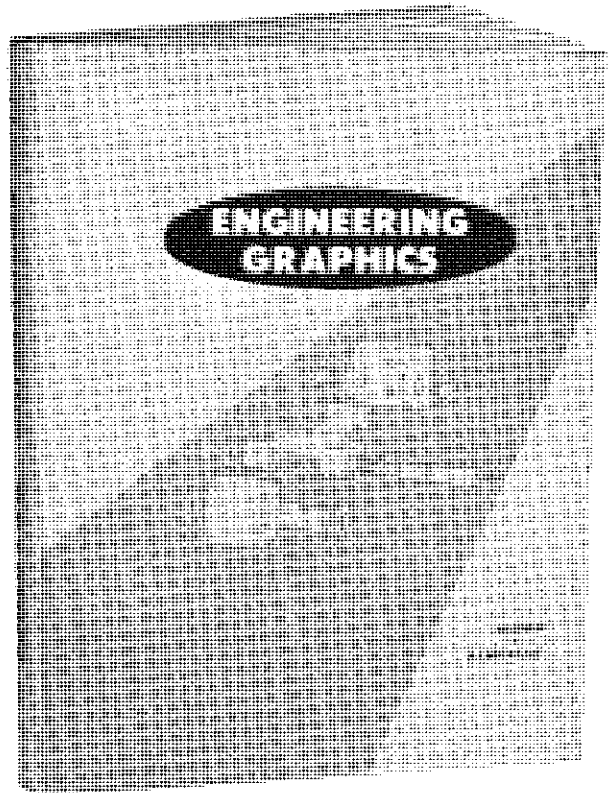

This text presents the basic principles and graphical theory of communication drawings in a logical and integrated manner. Innovations include the initial introduction of orthographic and multiview projection by the study of a point and its spatial location. Experience has shown that the student can better visualize the principles of projection applied to a point in space rather than to a solid object with the complications of invisible edges and surfaces. The next logical step joins two *points* to form a *line*, with succeeding steps to develop basic theory of the *plane* and the *solid*.

Included are numerous illustrations and all appear on the same or facing page as the related text material. This third edition contains an enlarged unit on Production Dimensioning which includes ASA cylindrical parts; Z and N charts; and concurrency charts. Practice problems from the several fields of engineering illustrating principles previously discussed are presented at the end of each unit.

416 pp. — Cloth Bound — \$7.25

WM. C. BROWN BOOK COMPANY

135 SOUTH LOCUST STREET • DUBUQUE, IOWA 52001



Problem Books for Engineering Graphics

Book I

by James S. Rising and Carl A. Arnbal
Iowa State University

This set of engineering graphics problems is keyed to the first 16 units of the text and is designed for a semester's work. Contained are 76 sheets of problems; layouts for practice of graphical theory, engineering applications and worded problems; and quality green tinted drawing paper for all problems. \$3.50

Book II

by Maurice W. Almfeldt and Carl A. Arnbal
Iowa State University

This set of engineering graphics problems is keyed to units 17-37 of the text and is designed for a semester's work. This workbook contains 88 sheets of problems; graph paper in 10 x 10, log and semi-log for the graphical analyses found in units 33-37; and quality green tinted drawing paper for all problems. \$4.50

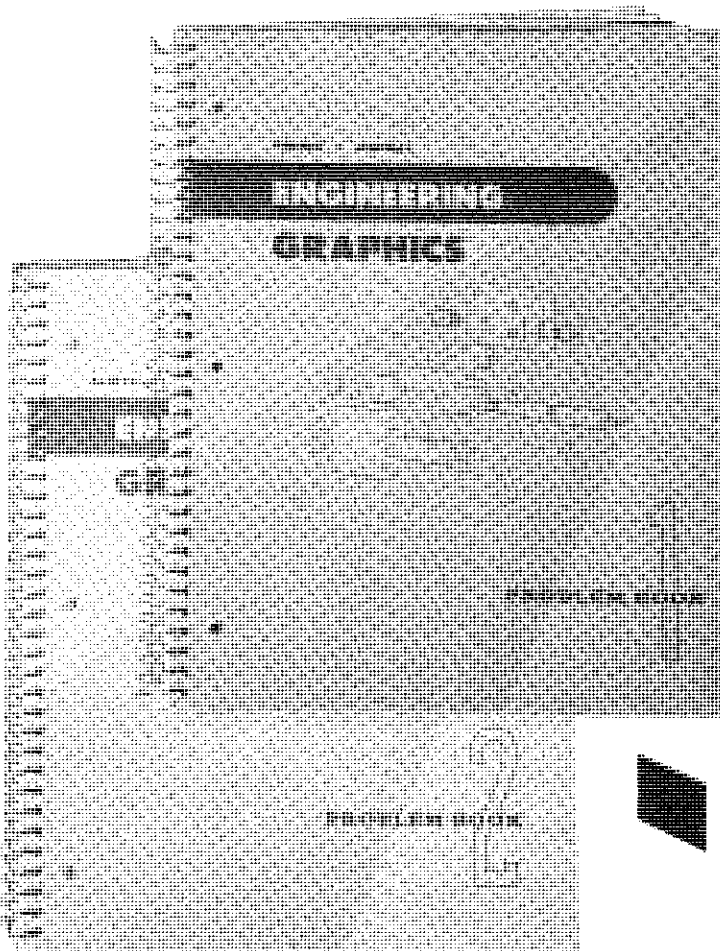

Special Edition Problem Books

Designed by You for Your Needs!

Select from Book I, Book II, and a stock of more than 280 additional problems only those problems for which you have a need. With a yearly use of 250 books minimum, we will prepare them to your design — you choose only those problems which you will use, the paper on which you wish to have the problems printed, and the binding you find most suitable. Samples of all problems will be furnished upon request, as well as copies of Books I and II, and the text.

NOTE: An answer key is available for those problems in Books I and II.

Some of the Schools Now Using . . .

SPECIAL EDITION PROBLEM BOOKS

- Michigan Technological University
- Drexel Institute of Technology
- University of Colorado
- City University of New York
- University of Massachusetts
- Louisiana State University
- University of Oklahoma
- University of North Dakota

WM. C. BROWN BOOK COMPANY

135 SOUTH LOCUST STREET • DUBUQUE, IOWA 52001



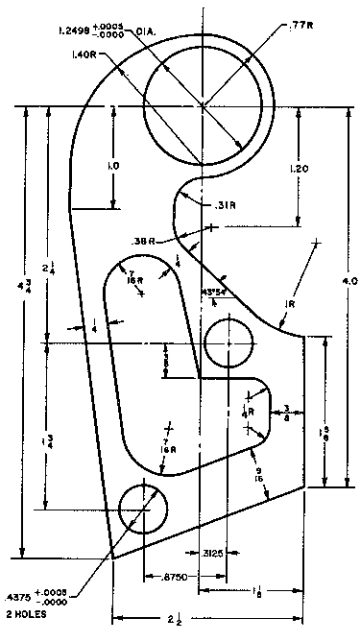

Figure 5. Conventional part drawing supplies programmer with all necessary information on part contour.

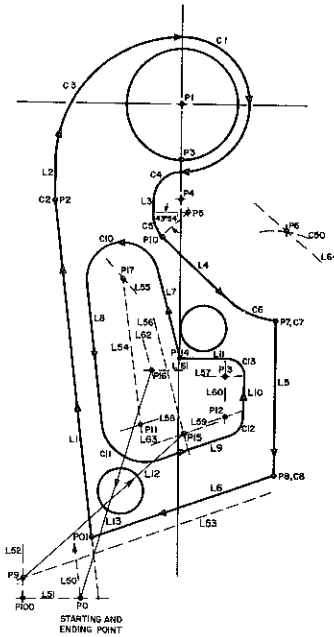
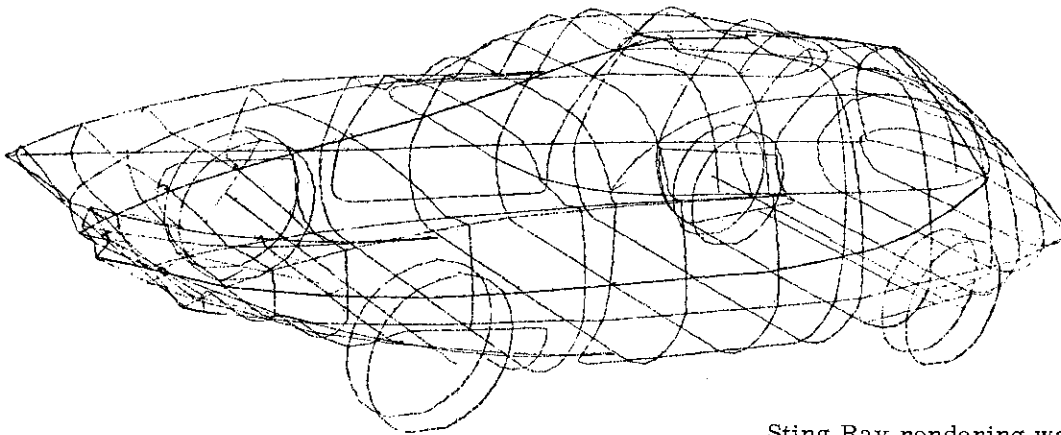
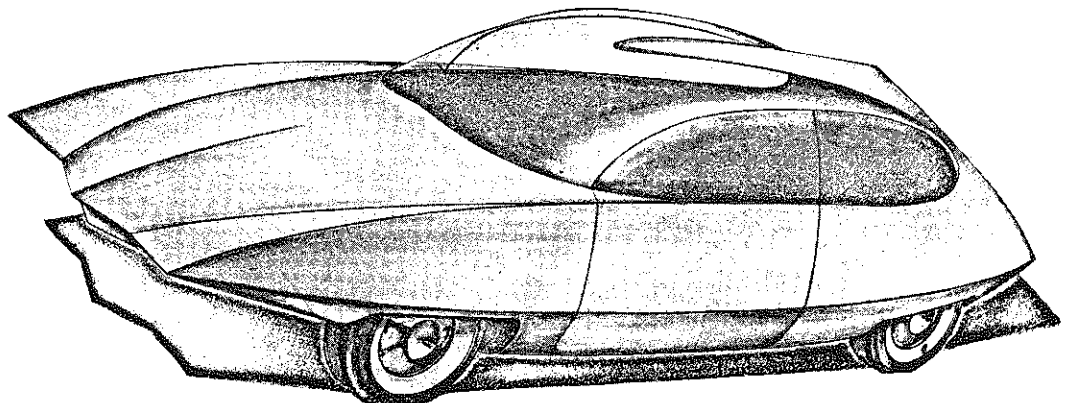

Figure 6. As the first step in programming with CINAP-1, each line, circle and point of part contour is identified with a symbolic letter and a number.



Flat edge of wheels shows accuracy of drawing with numerical data. Computing time for the first drawing was four minutes, and only one minute for each additional view.

Sting Ray rendering was finished by hand after being drawn on a numerically controlled drafting machine. Data for numeric tape was processed from punched cards by a computer.



SAMPLE No. 1

This 3/8" scale model of a synthetic camphor plant was built by American Hydrotherm Overseas Corporation - with E.M.A. materials - and without the use of professional model makers.

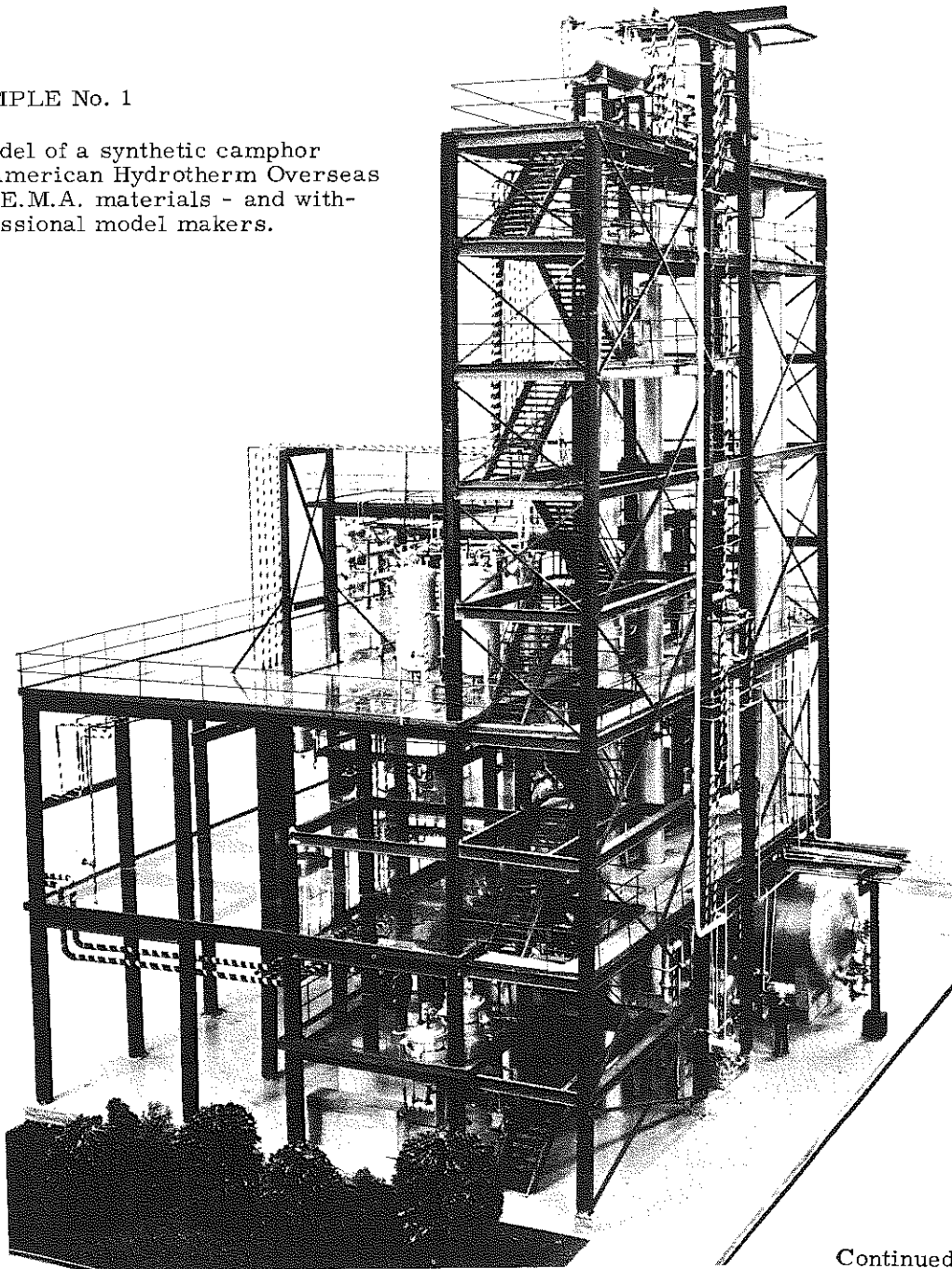

Continued on Page 65

WITICISMS

Change is the one unchanging thing today.



Our job of education is to train students in how to cope with new situations and new complications, to develop critical judgments of new problems as they occur for solution.



An open mind does not require the abandonment of your principles and ideals.



A good leader has a mission that overshadows personal ambition.



The clock of life is wound but once and no man has the power to tell just when the hand will stop, at late or early hour.



FIVE TESTED TEACHING AIDS FOR ENGINEERING DRAWING



BY CARL L. SVENSEN AND WILLIAM E. STREET

FOR USE WITH ANY TEXT OR NO TEXT

DRAFTING PROBLEM LAYOUTS

SERIES D, REVISED 1962

Work sheets covering Vertical and Inclined Lettering, Sketching, Use of Instruments, Engineering Geometry, Scales, Orthographic Projection, Revolution, Auxiliary Projection, Sections and Conventions, Isometric, Oblique, Dimensioning, Developments, Intersections, Screw Threads and Studies of Points, Lines, and Planes.

100 Work Sheets, 8 1/2" X 11" _____ \$4.00

DRAFTING PROBLEM LAYOUTS

SERIES C, REVISED 1964

Work sheets covering Vertical and Inclined Lettering, Sketching, Use of Instruments, Engineering Geometry, Scales, Orthographic Projection, Revolution, Auxiliary Projection, Sectional And Conventions, Dimensioning, Screw Threads and Bolts, Isometric, Oblique, Perspective, Developments, Intersections, Working Drawings.

95 Work Sheets, 8 1/2 " X 11 " _____ \$4.00

LETTERING EXERCISES

A DIRECT METHOD - NEW AND INTERESTING

Vertical and Inclined Lettering with eight sheets of extra problems.

20 Work Sheets, 8 1/2 " X 11 " _____ \$1.50

VERTICAL LETTERING EXERCISES

Vertical Lettering with instructions

6 Work Sheets, 8 1/2 " X 11 " _____ \$0.60

INCLINED LETTERING EXERCISES

Inclined Lettering with Instructions

6 Work Sheets, 8 1/2 " X 11 " _____ \$0.60

WRITE FOR EXAMINATION COPY OR ORDER FROM

W. E. STREET
ENGINEERING GRAPHICS DEPARTMENT
LOUISIANA STATE UNIVERSITY
BATON ROUGE, LOUISIANA 70803

Prepare your own problem book by selecting your drawings from these books in quantities of 25 or more of each layout.
Allow 90 days for order.

The Journal of Engineering Graphics

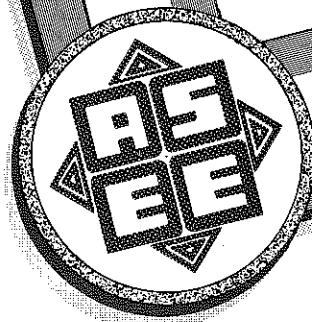

Lay your triangle along here, tear off and mail to:

James H. Earle, Engineering Graphics Department
Texas A & M University, College Station Texas

Please enter my subscription to the Journal of
Engineering Graphics. 1 yr. \$2. 2 yrs. \$4
Enclose check or money order

Name _____
Address _____
City _____
State - Zip Code _____

YOU WILL NOT BE TAUGHT HOW TO DESIGN FLYING MACHINES

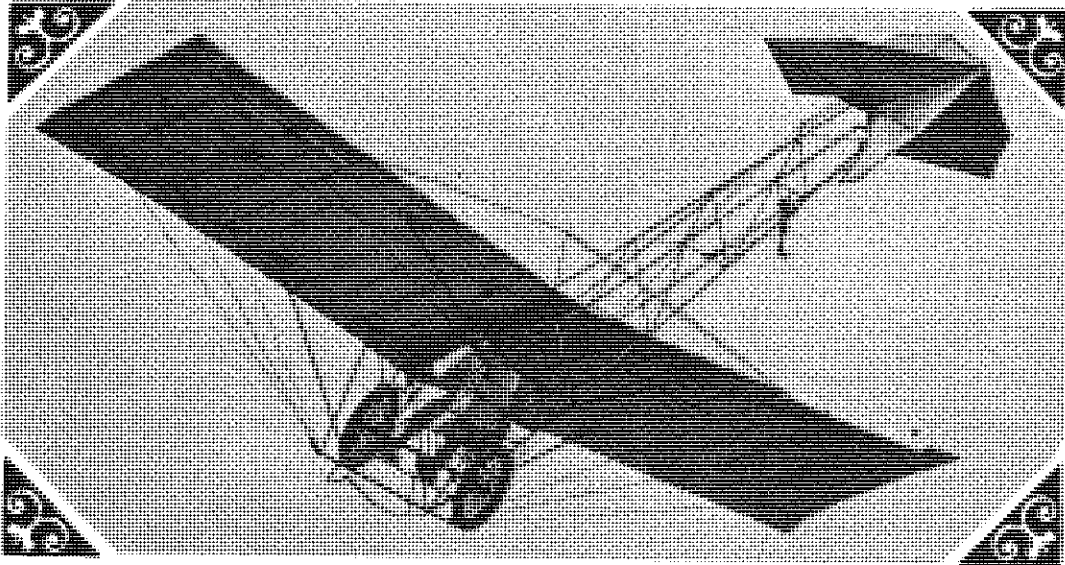

YOU WILL BE TAUGHT HOW TO DESIGN

Announcing the 1967 A. S. E. E. SUMMER SCHOOL IN ENGINEERING GRAPHICS AND DESIGN - June 15, 16, 17 at Michigan State University, Kellogg Center, East Lansing, Michigan immediately prior to the Annual Meeting.

PURPOSE:

To present engineering graphics as a vehicle for instruction in engineering design. To broaden the education outlook of engineering graphics teachers in the area of design education. To give teachers intense coaching on curriculum planning, writing of case studies, selection and writing of design projects, and the role of graphics in design education. To bring recognized authorities in design education in contact with graphics teachers. Above all, to teach teachers how to teach design.

FORMAT:

The summer school will be conducted on a lecture-workshop basis with every effort made to involve attendees in actual problem solving sessions so that they may experience what their students will be required to do. Lectures will be somewhat formal (entire group in attendance). Workshops will be informal in nature with coaches (limited to about 25).

COMMITTEE:

Percy H. Hill (Tufts University)-Chairman
Earl D. Black (General Motors Institute)
Peter Z. Bulkeley (Stanford University)

Jerry S. Dobrovolny (Univ. of Illinois)
Matthew McNeary (University of Maine)
William B. Rogers(U. S. Military Academy)

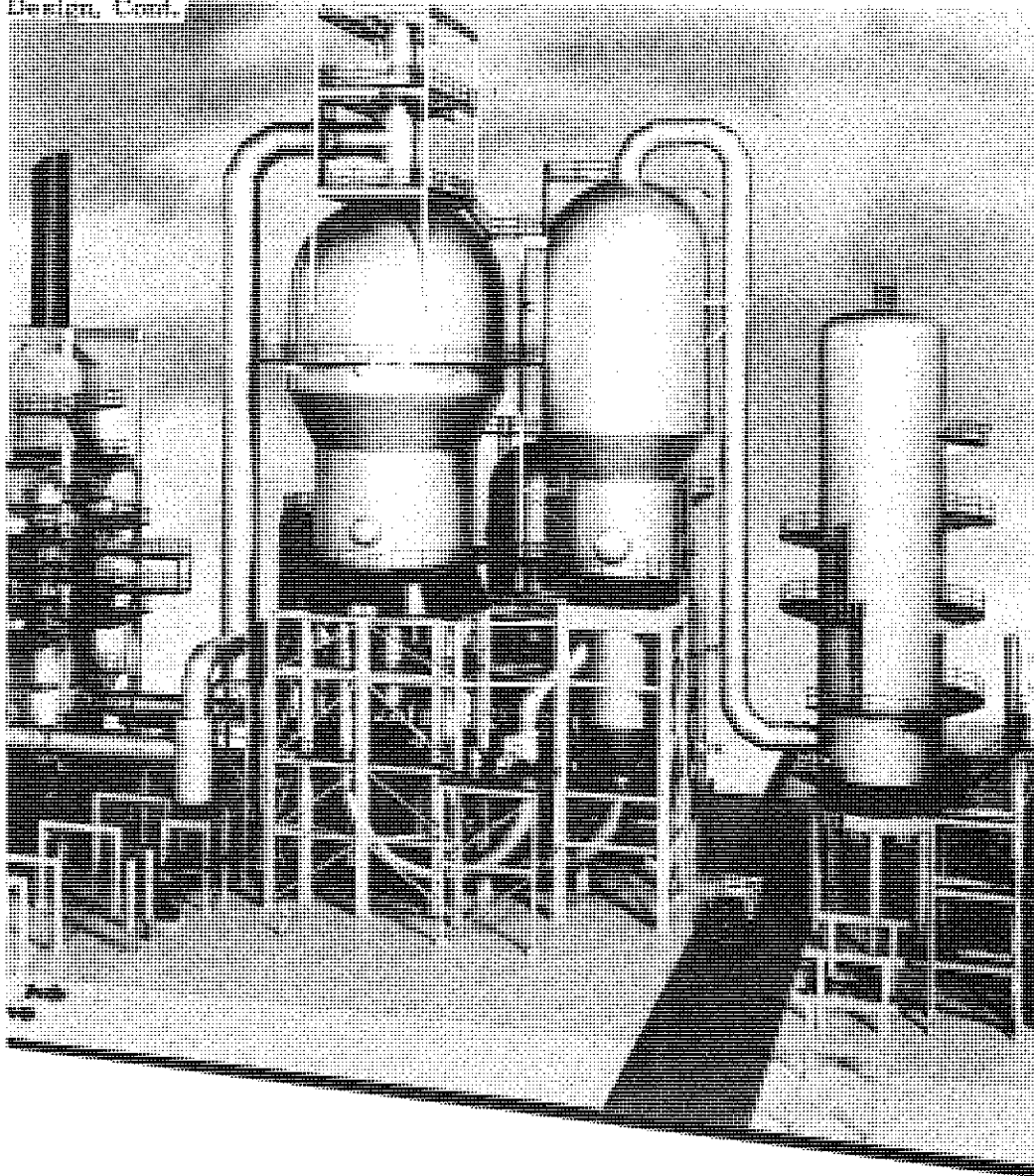

Typical applications of structural shapes, railings, stairs and ladders.

If one's language is not correct, then what is said is not meant; if what is said is not meant, then what should be done remains undone, and the people only stand around in helpless confusion.

--Confucious



Knowing what we don't know is often more important than knowing what we know.

GUIDE TO THE INDEX:

Each entry is accompanied by a notation such as "NF 63,6." This means that the item or author's name is in the November (Fall) 1963 issue, and that the item begins or the author's name is on page 6. FW means February (Winter issue). MS means May (Spring issue).

SUBJECT INDEX:

In some instances, changes in titles have been made where original titles are not sufficiently indicative of the subject content. Articles dealing with several topics are listed under the several headings.

E. D. B.

CITATION

- Robert Holmes Hammond, U. S. Military AcademyNF66, 4
- Frank Oppenheimer, Gramercy Guild Group, Inc.NF66,26
- James Sinclair Rising, Iowa State UniversityNF66, 4

COMMUNICATION

- Communication Needs in Engineering Education, J. Stuart Johnson, Wayne State University. FW66,11
- Uses of Graphical Communication in Industry, William C. Killen, GM Corp. Pontiac Motor Division FW66,13

COMPUTER DRAFTING

- Computer Drawings by Engineering Graphics Students, Norman Buchanan, Pennsylvania State University. MS66,27
- Numerical Control Drafting, Donald C. Beran, General Motors Institute. MS66,17

DESCRIPTIVE GEOMETRY

- Descriptive Geometry, A Self-Dependent Spatial Science, Thaddeus D. Pozniak, Conisius College of Buffalo, N. Y. NF66,21
- Fundamental Theorems of the Geometry of Four Dimensions, Louisa Bonfiglioli, Technion - Israel Institute of Technology. NF66,15
- A Rare Application of Descriptive Geometry, James H. Earle, Texas A&M University. MS66,15

DESIGN

- Automation of Design with Modern Techniques and its Impact on Engineering Graphics, Jacob H. Sarver, University of Cincinnati . NF66,11

ENGINEERING ANALYSIS

- The Use of Graphics in Engineering Analysis, William G. Lambert, West Virginia University. FW66,15

ENGINEERING EDUCATION

- A Case for the Experienced Professional Teaching in the Freshman Area of Undergraduate Engineering Instruction, Arthur H. Mallon, Tufts University. MS66,24
- Change, Progress, and Controversy, Earl D. Black, General Motors Institute MS66, 5
- Comments on the Goals of Engineering Education, Jerry S. Dobrovolny, University of Illinois MS66,20
- Some Comments on the Goals Report, Eugene G. Paré, Washington State University. FW66,26

- Communication Needs in Engineering Education, J. Stuart Johnson, Wayne State University. FW66,11
- Cultural Clods or Illiterate Technicians, William B. Rogers, U. S. Military Academy. FW66, 6
- By the Grape Vine About the Goals of Engineering Education, Earl D. Black, General Motors Institute . MS66,25
- "Graphics Extracts", Edward W. Jacunski, University of Florida . FW66,26
- Is There A Doctor in the House? Edward W. Jacunski, University of Florida MS 66, 6

ENGINEERING GRAPHICS

- A Rare Application of Descriptive Geometry, James H. Earle, Texas A&M University MS 66,15
- Change, Progress, and Controversy, Earl D. Black, General Motors Institute MS 66, 5
- The Educational Value of Graphics, Frank A. Heacock, Princeton University. NF66,23
- Engineering Graphics -- Static or Dynamic, Earl D. Black, General Motors Institute. NF 66, 5
- The Engineering Graphics Program in the Pacific Northwest, Byers, Campbell, Pare, Hammer -- Washington MS 66,13
- A Look in the Mirror, Earl D. Black, General Motors Institute FW66, 4
- Opinions of Educators and Engineers on the Importance of Engineering Graphics Topics, Ernest C. Schamehorn, Western Reserve University FW66,17
- The Result of Complete Dimensional Reform, Alpheus C. Bemis, General Motors Institute MS 66,56
- A Short Glance Backward and A Long Look Ahead, Warren J. Luzadder, Purdue University. FW66,25

ENGINEERING GRAPHICS COURSES

- A Technical One-Year Drawing Course for College Preparatory Students, Educational Relations Committee FW66,23

FILE TO FILE

- Can You Draw the Correct Right End View? E. W. Knoblock, The University of Wisconsin -- Milwaukee. FW66,43
- Have You Solved These? Earl D. Black, General Motors Institute . MS 66,40
- A Solution for "Can You Solve This Problem?" Al Romeo, The Ohio State University. MS 66,40
- An Application of Desargues' Theorem, Robert W. Bosma, Princeton University NF 66,24
- A Solution for Three Unknown Forces, John P. Oliver, Texas A&M University. FW66,36

Three-Prong U-Bar and Carrying
Case With Applications, William C.
Carpenter and H. W. Blakeslee,
Central Florida Junior College. . MS 66,44
Tunnel Design Problem, R. R. Worsen-
croft, University of Wisconsin . . FW66,30

FOUR-DIMENSIONAL GEOMETRY

Axonometric Picture and Steroscopic
Model for Four-Dimensional
Euclidean Geometry, Louisa
Bonfiglioli, Technion - Israel
Institute of Technology FW66,19
Fundamental Theorems of the
Geometry of Four Dimensions,
Louisa Bonfiglioli, Technion -
Israel Institute of Technology . . NF 66,15

IN MEMORIAM

Richard Carpenter, Purdue University,
by J. Howard Porsch MS 66,28
Frank A. Heacock, Princeton Univer-
sity, by A. P. McDonald (Rice
Institute) NF 66,26
James J. Devine, Northeastern Uni-
versity, by Borah Kreimer NF 66,26

PROBLEMS (See File to File)

PROJECTIVE GEOMETRY

Peculiar Lines and Planes, V. P.
Borecky, University of Toronto . FW66,20
A Projective Solution to "Can You
Solve This Problem," F. M.
Hrachovsky, Illinois Institute of
Technology MS 66,55

TEACHING TECHNIQUES

Inventive Design Instruction Tech-
niques, Percy H. Hill, Tufts
University MS66, 11
The Thought-Model Method of Teach-
ing Spatial Visualization, Alexander S.
Levens, University of California,
Berkeley. NF 66,13

TECHNOLOGY

On an Application of Desargues'
Theorem, Robert W. Boxma,
Princeton University NF 66,24
Axonometric Picture and Steroscopic
Model for Four-Dimensional
Euclidean Geometry, Louisa
Bonfiglioli, Technion - Israel
Institute of Technology FW66,19

A Graphical Solution for the Powers
and Product Combinations of the
Powers of Sin θ and Cos θ ,
Warren G. Lambert, West Virginia
University. MS 66,36
Peculiar Lines and Planes, V. P. . . FW66,20
Borecky, University of Toronto . VW66,20
On Transposing Nomograms to Slide
Rules, L. M. Weiner, Illinois
Teachers College, Chicago -
North NF 66,17

AUTHOR INDEX :

With few exceptions, universities, colleges, and titles in the Author Index are listed as they appear in the Journal of Engineering Graphics.

B

BEMIS, Alpheus C., General Motors
Institute. The Result of Complete
Dimensional Reform MS 66,56
BERAN, Donald C., General Motors
Institute. Numerical Control
Drafting MS 66,17
BLACK, Earl D., General Motors
Institute. Change, Progress, and
Controversy. (Editorial). MS 66, 5
Engineering Graphics -- Static or
Dynamic. (Editorial). NF 66, 4
Have You Solved These? (File to
File). MS 66,18
By the Grape Vine About the Goals
of Engineering Education. MS 66,25
A Look in the Mirror. (Editorial) . . FW66, 4
Index, Volume 30 NF 66,58
BLAKESLEE, H. W., Central Florida
Junior College, Ocala. Pictorial
Design Problem. (File to File) . . NF 66,25
BONFIGLIOLI, Louisa, Technion -
Israel Institute of Technology.
Axonometric Picture and Stero-
scopic Model for Four-Dimensional
Euclidean Geometry FW66,19
Fundamental Theorems of the
Geometry of Four Dimensions . . NF 66,15
BORECKY, V. P., University of Toronto.
Peculiar Lines and Planes FW66,20
BOSMA, Robert W., Princeton University.
On an Application of Desargues'
Theorem NF 66,24
BUCHANAN, Norman, Pennsylvania
State University. Computer Draw-
ings by Engineering Graphics
Students. MS 66,27
BYERS, Roland, University of Idaho,
et.al. The Engineering Graphics
Program in the Pacific North-
west. MS 66,13

C

CAMPBELL, John, Oregon State
University. et.al. The Engineer-
ing Graphics Program in the
Pacific Northwest. MS 66,13
CARPENTER, William F., Central
Florida Junior College, Ocala.
Three-Prong U-Bar and Carry-
ing Case with Applications MS 66,44
COUZZENS, Charles R., West Texas
State University, et.al. The Summer
Drafting Institute at Texas A&M
University NF 66,19

D

DOBROVOLNY, Jerry S., University of Illinois, Urbana. Comments on the Goals of Engineering Education Preliminary (Committee) Report. MS 66,20

E

EARLE, James H., Texas A&M University. A Rare Application of Descriptive Geometry. MS 66,15
 HAMMER, Vernon, Washington State University, et.al. The Engineering Graphics Program in the Pacific Northwest. MS 66,13
 HEACOCK, Frank A., Princeton University. The Educational Value of Graphics. NF 66,23
 HILL, Percy H., Tufts University. Inventive Design Instruction Techniques. MS 66,11
 HRACHOVSKY, F. M., Illinois Institute of Technology. Projective Geometry Solution to "Can You Solve This?" MS 66,55

J

JACUNSKI, Edward W., University of Florida. "Graphics Extracts." . FW66,26
 Is There A Doctor in the House . MS 66, 6
 JOHNSON, Gary, West Texas State University et.al. The Summer Drafting Institute at Texas A&M University. NF 66,19
 JOHNSON, J. Stuart, Wayne State University. Communication Needs in Engineering Education. FW66,11

K

KILLEN, William C., Pontiac Motor Division, GM Corporation. Use of Graphical Communication in Industry. FW66,13
 KNOBLOCK, E. W., The University of Wisconsin - Milwaukee. Can You Draw the Correct Right-End View? (File to File) FW66,43
 KREIMER, Borah, Northeastern University. In Memoriam to James J. Devine. NF 66,26

L

LAMBERT, William G., West Virginia University. A Graphical Solution for the Powers and Product Combinations of the Powers of the Sin θ and Cos θ MS 66,36
 The Use of Graphics in Engineering Analysis FW66,15
 LANG, Robert, Northeastern University. A Technical One-Year Drawing Course for College Preparatory . FW66,23
 LEVENS, Alexander S., University of California, Berkeley. The Thought-Model Method of Teaching Spatial Visualization. NF 66,13

LUZADDER, Warren J., Purdue University. A Short Glance Backwards and a Long Look Ahead. FW66,25

M

McDONALD, A. P., Rice Institute. In Memoriam to Frank A. Heacock . . NF 66,26

MALLON, Arthur H., Tufts University. A Case for the Experienced Professional Teaching in the Freshman Area of Undergraduate Engineering Instruction. MS 66,24

O

OLIVER, John P., Texas A&M University. A Solution for Three Unknown Forces. FW66,36

P

PARE, Eugene G., Washington State University. Some Comments on the Goals Report. FW66,26
 The Engineering Graphics Program in the Pacific Northwest. MS 66,13
 PORSCH, J. Howard, Purdue University. In Memoriam to Richard Carpenter. MS66, 28
 POZNIAK, Thaddeus D., Conisus College of Buffalo. Descriptive Geometry, A Self-Dependent Spatial Science NF 66,21

R

ROGERS, William B., U. S. Military Academy. Cultural Clods or Illiterate Technicians FW66, 6
 ROMEO, Al, The Ohio State University. A Solution to the "Can You Solve This?" Problem. MS 66,40

S

SARVER, Jacob H., University of Cincinnati. Automation of Design with Modern Techniques and its Impact on Engineering Graphics . NF 66,11

SCHAMHORN, Ernest C., Western Reserve University. Opinions of Educators and Engineers on the Importance of Engineering Graphics FW66,17

W

WEINER, Louis M., Illinois Teachers College, Chicago - North. On Transposing Nomograms to Slide Rules. NF 66,17
 WORSENCROFT, Robert R., University of Wisconsin - Madison. Tunnel Design Problem. (File to File). . FW66,30



