

JOURNAL OF ENGINEERING DRAWING

VOL. 11 NO. 3

NOVEMBER, 1947

SERIES NO. 33

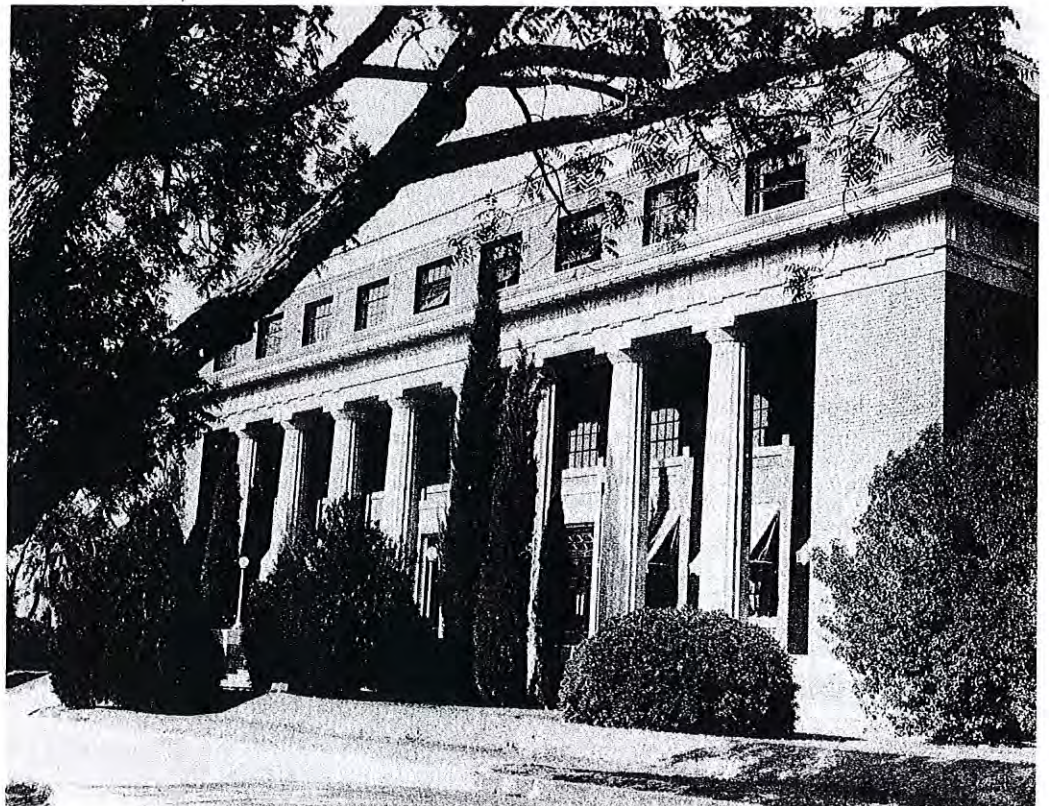

ENGINEERING BUILDING
UNIVERSITY OF ARIZONA

**PUBLISHED
BY
THE
DIVISION
OF
ENGINEERING
DRAWING
AND
DESCRIPTIVE
GEOMETRY
A S E E**

**SINCE
1911**

*New
Seventh
Edition*

THE CLASSIC ENGINEERING DRAWING TEXT

French's **ENGINEERING DRAWING**

By THOMAS E. FRENCH, Late Professor of Engineering Drawing, The Ohio State University. Revised by CHARLES J. VIERCK, Professor of Engineering Drawing, The Ohio State University. 702 pages, 6 x 9, 1229 illustrations. \$3.75

THE career of French's *Engineering Drawing* has made textbook history. Since 1911 this classic text has held first place on the drawing boards of hundreds of thousands of students in colleges, universities, and technical schools throughout this country and abroad.

In literary style, logical arrangement, and general teachability, it has been preeminent. For

over three decades, each edition has raised the standard of excellence set by previous editions, and the present revision again keeps the text abreast of the very latest advances in engineering drawing.

This new edition adds several new chapters, many new illustrations, and a large number of problems reflecting present-day practice. A

considerable amount of the old material has been revised, drawings have been revised where necessary to eliminate duplications and ambiguities, and the fundamental chapters I to X have all been revised to improve the order and to achieve clearer, more logical explanations.

In praise of the previous edition

"I don't see how it could well be much better. For everything that anyone needs is in it; not only in it, but also clearly explained. Congratulations to you and to Professor French on producing a technical book that America can be proud of."

PROFESSOR WILLIAM H. RASCHE
Virginia Polytechnic Institute

**CORRELATED WITH
French's
ENGINEERING DRAWING**

TEXT-FILMS on ENGINEERING DRAWING

* SOUND MOTION PICTURES

For explanation and demonstration

* SILENT FILMSTRIPS

For follow-up class review and discussion.

* AVAILABILITY

McGraw-Hill Text-Films are available through outright purchase of prints from the McGraw-Hill Book Company, 330 West 42nd Street, New York, N. Y.

Selected parts of the French text are now supplemented by a series of 7 sound motion pictures, and 6 coordinated silent filmstrips. Terminology and general approach is identical in films and textbook. However, the purpose of Text-Films is extended coverage of the subject rather than mere duplication on film of what is already in the book.

The motion pictures explain theories and demonstrate techniques in those phases of the subject that are generally found to be most difficult for the student to understand. The filmstrips are planned primarily as follow-ups to the motion pictures. They re-emphasize key points in both motion picture and textbook, present review questions, and offer additional factual material.

Additional Aids

FOR ENGINEERING DRAWING STUDENTS

ENGINEERING DRAWING SHEETS - Series F

By THOMAS E. FRENCH and H. M. McCULLY. Keyed to the New 7th Edition of FRENCH'S *ENGINEERING DRAWING*. In press.

These sheets are designed to make the most economical use of time allowed for drawing courses. The careful arrangement of lesson sequence; the increased attention to reading drawings and technical sketching; the time-saving layouts of problems in projections; sections, dimensioning, lettering, working drawings, combine to make a course that compels student interest.

PROBLEMS IN ENGINEERING DRAWING

By A. S. LEVENS and A. E. EDSTROM Series 2, keyed to the New 7th Edition of FRENCH'S *ENGINEERING DRAWING*. \$3.00

This well-known and widely-liked workbook has been carefully revised and enlarged from 62 to 72 worksheets. Its primary purpose is to provide, in a minimum number of plates, sufficient practice to enable the student to master the techniques of drawing in accordance with practice established by the American Standards Association.

**McGRAW-HILL
BOOK CO., Inc.**

330 WEST 42nd STREET
NEW YORK 18, NEW YORK

JOURNAL OF ENGINEERING DRAWING
PUBLISHED IN THE INTEREST OF TEACHERS OF ENGINEERING DRAWING
AND RELATED SUBJECTS

VOL 11 NO. 3

NOVEMBER, 1947

SERIES NO. 33

CONTENTS

FRONTISPIECE: Illustrated by Professor O. M. Stone, Case Institute of Technology	Page 4
SO YOU HAVE DECIDED TO BE A DRAWING TEACHER?, by H. C. Spencer, Illinois Institute of Technology.	Page 5
REPORT OF THE S.P.E.E. DRAWING AND DESCRIPTIVE GEOMETRY DIVISION COMMITTEE ON NOTATION AND NOMENCLATURE FOR DESCRIPTIVE GEOMETRY.	Page 8
A.S.E.E. MEETING HIGHLIGHTS by Prof. O. W. Potter, University of Minnesota.	Page 12
DEVELOPING RESPONSIBILITY AND INITIATIVE IN STUDENTS THROUGH TEACHING LETTERING AND SKETCHING, by Geo. J. Hood, University of Kansas	Page 14
PROBLEM SOLUTION, by Prof. John C. Rule, M.I.T.	Page 16
SOLVE THIS ONE, a descriptive geometry problem.	Page 16
TEACHING TOLERANCES, by J. Gerardi and O. B. Noren, University of Detroit.	Page 20
LETTER FROM H. C. T. EGGERS, University of Minnesota.	Page 22
WHY THE 4 CENTER APPROXIMATE ELLIPSE-ELLIPSES? by A. J. Philby, Ohio State University.	Page 26
COMMITTEE REPORTS Paffenbarger, Ohio State Howe, Rensselaer Fenwick, Louisville.	Page 27
ENGINEERING EDUCATION IN THE FRESHMAN DRAWING ROOM, by Paul Hessemer, John Hopkins University	Page 31

Annual Subscription Price, \$1.00

PUBLISHED IN FEBRUARY, MAY, AND NOVEMBER BY
THE DIVISION OF ENGINEERING DRAWING AND DESCRIPTIVE GEOMETRY OF THE
AMERICAN SOCIETY FOR ENGINEERING EDUCATION

PUBLICATION COMMITTEE

T. T. Aakhus, Editor
University of Nebraska
LINCOLN, NEBRASKA

J. N. Wood, Advertising
Kansas State College
MANHATTAN, KANSAS

Ralph T. Northrup, Cir. & Treas.
Wayne University
DETROIT, MICH.

DRAFTSMANSHIP
IS THE
VITAL BRIDGE
BETWEEN
CONCEPTION
AND
PRODUCTION

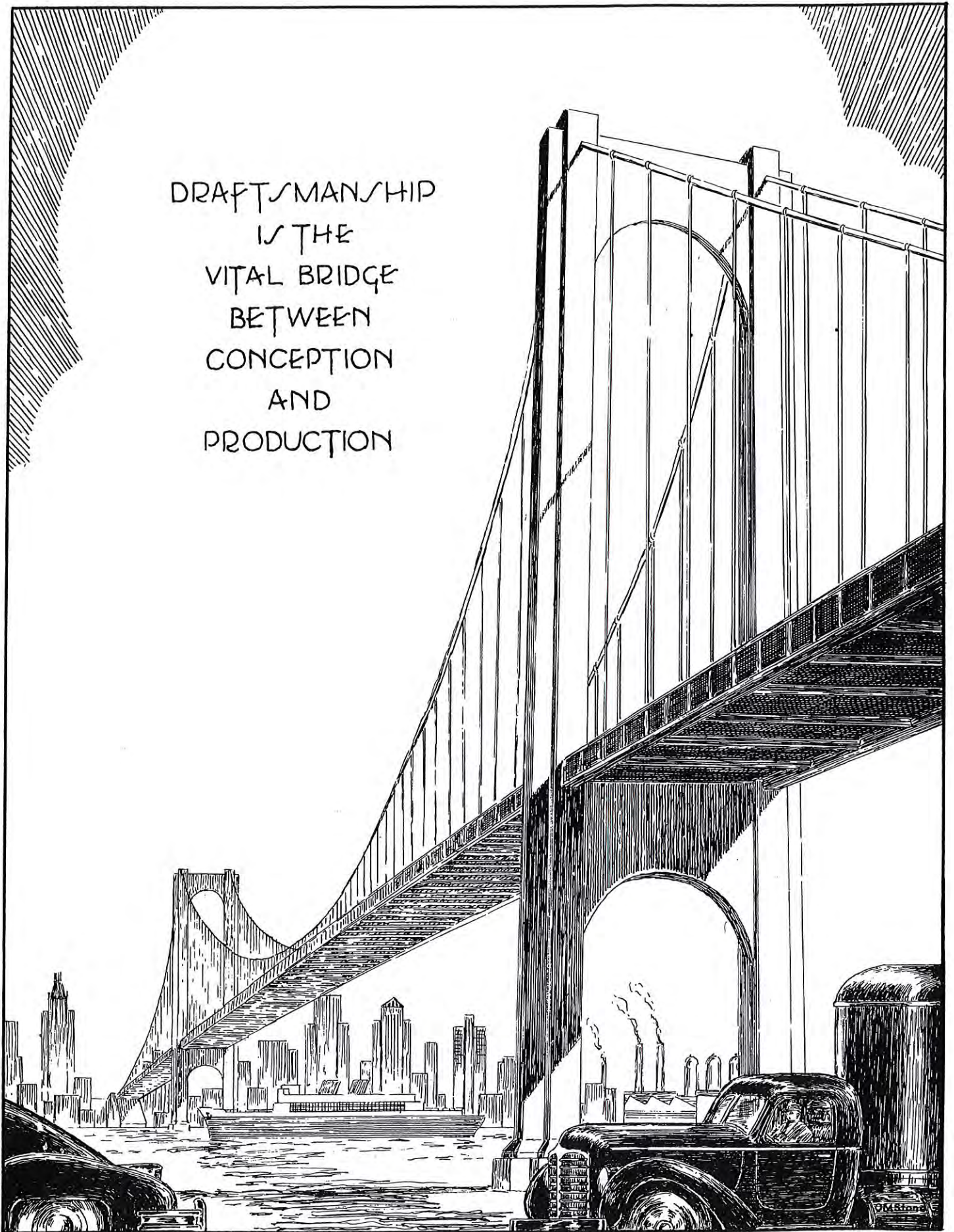

SO YOU HAVE DECIDED TO BE A DRAWING TEACHER?

by

H. C. Spencer
Chairman, Technical Drawing Department
Illinois Institute of Technology

These remarks are directed primarily to the young graduate who is seriously considering the teaching of engineering drawing as his life's work, as well as to the sincere man who has taught for years, but who is still uncertain of his choice. In addition, there are a few who have taught extensively, but who, nevertheless, may be wholly unsuited to their work.

First, let us take up the Almighty Dollar. A man who selects teaching as his life's work chiefly on the basis of financial return is wrong to start with, and I find it difficult to sympathize with him if he is unhappy - it serves him right! Without going into the advantages of teaching as a vocation and there are many - we can certainly say that when a man enters the teaching profession he supposedly has his eyes open and that he should make up his mind one way or the other, and not spend the remainder of his life complaining of the poor compensation.

Joe Doaks somehow obtained his engineering degree. Then the school experienced a sudden increase in enrollment, and the Engineering Drawing Department looked around, and there was Joe. Twenty-four hundred dollars for nine months - not bad! And summer vacations off too!

Joe started his first year like a house afire. In fact, he had to work pretty hard to stay two jumps ahead of his students. But in the following year, surprisingly, he was pleased to realize that he had learned the tricks of the trade more quickly than he had expected, and he had time on his hands. He married, purchased a set of Montgomery-Ward golf clubs, and settled down to be a "college professor".

Now, Joe was a good egg around the department - you couldn't help but like the guy! Of course, he made himself pretty scarce around the office. He knew that all the extra jobs fell to the fellow who didn't have sense enough to go home when his class was over. Don't get me wrong: Joe did everything he was asked to do, but he never did think up anything to do on his own. He had a short-cut system for all routine work that was a beauty to behold! All menial tasks, such as preparing quizzes, grading, etc., were organized with the central idea of making it quick and easy for Joe. He was a quiet, easy-going fellow, who never got worked up about anything - anything, that is, except salary. Now there was something on which Joe

showed righteous indignation. "After all," he would say, "I've been here all these years, and look what I get!"

Joe didn't pretend to be a good draftsman. He could "tell others how," but actual drafting was boresome work for which he had a real distaste. He would jokingly tell his students, "You'll never pass my course if you can't learn to letter better than I can".

Among engineering teachers, Joe had a definite feeling of inferiority. Down inside, he felt that he was professionally below a teacher of an advanced subject, and that he was wasting his talents in teaching freshmen. It apparently never dawned on Joe that engineering drawing is an extremely broad field, and actually he had not the slightest conception of how difficult his job really was. Most other engineering teachers had, in many ways, a relatively narrow field in which to work. A mechanical engineer, for example, could specialize in machine design or kinematics, and would have the advantage of teaching only mechanical engineering students. The engineering drawing teacher, however, has students in all the major technical fields, and yet he could hardly be thoroughly trained in more than one. His problem would be to learn as much as he could about the other fields, and this process would have to continue indefinitely.

Even more important, he would have to become an expert in engineering graphics - a complex field in itself. This he must consider to be the focal point of all his interest and development, and would alone keep him busy the rest of his life.

The young engineering graduate starting as a drawing teacher has probably had no more training than the students in his classes. His first effort would logically be to take those graphical courses which were not in his undergraduate curriculum, such as machine design or topographic drawing. He must take these formally, or dig them out for himself at home. In any case, he must embark upon a lifetime of methodical study of all the branches of the field of engineering graphics.

He owes it to himself to get his Master's degree as soon as possible, either in engineering or in education. Whatever you may think of degrees, remember that colleges pay off their students in terms of degrees, and the teachers therein are expected to have complete academic training.

Although the individual teacher within a department can specialize in only one major engineering field, a cross-section of the staff might show a balanced distribution of the several fields. The group would include graduates of each of the major branches of engineering, with perhaps a science major and an architectural or industrial education graduate. These teachers can and should learn much from each other.

If we suppose that the teacher has obtained his basic technical training, does it necessarily follow that he is now a fully-qualified teacher? Obviously, he needs to learn something about how to put his subject across to his students. In the progress of education, many brilliant minds have given thought to teaching methods, and it is presumptuous, to say the least, for a teacher to assume that he can figure out on his own all that he might well know about methods of teaching. Even if he could do so, he could learn more quickly and more effectively if he consulted the works of others first. It does no good for the obstinate engineering teacher to argue, as he is apt to do through a certain defense psychology, that education courses are often poorly taught, for that is true of engineering subjects as well.

While Prof. Hoelscher's excellent book, "Methods of Teaching Mechanical Drawing", is the only available text of its kind, there are many helpful books on the science of teaching. Among these are Creative Teaching by Struck, The Background of College Teaching by Cole, Teaching: Profession and Practice by Brubacher, and many others.

The professionally-minded teacher keeps up with the literature in his field. This is difficult in our work because graphics is so broad in scope, and the related fields are almost limitless in number and extent. However, to see where you stand, compare your outside reading with that of a progressive chemical or electrical engineering teacher.

Naturally, the progressive teacher will familiarize himself with the new books on graphics and related technical fields, and buy the best of these for his personal library. Joe Doaks, one may be sure, obtained free books when he could, but seldom did he buy one. His professional library consisted of little more than the complimentary copies he used in his classes. He was completely oblivious to the fact that the size of one's personal library is a reliable index to his professional activity.

The up-to-date teacher is a regular subscriber to The Journal of Engineering Drawing, and keeps a complete file of these, together with the papers of the 1930 and 1946 Summer Schools. He also subscribes to one or two magazines, such as Machinery or Product Engineering, and makes use of others in the college library.

Another index to a teacher's progressiveness is his membership in professional societies, such as the ASEE, ASME, AIEE, etc. The ASEE is the most important for the engineering drawing teacher, but he should also be an active member of a society in the field of his undergraduate interest.

Furthermore, he should know something about applied engineering, since it is presumed that most of his students will eventually go into industry. The engineering teacher cannot afford to be ignorant of this great realm beyond the classroom. Somewhere in his experience he should have worked in industry, preferably in drafting or engineering, or both. If this experience is not gained before his starting as a teacher, it can and should be obtained during summer vacations or otherwise. Certainly, at least, he should visit industries from time to time, and learn what he can.

Much has already been said about the character of the teacher, but there are a few fundamental principles which must be mentioned again. First of all, a man should not select teaching as his profession unless he has a deep natural desire to render service to others. Such a person is not recognized by ostentatious pretensions to improve mankind, but by a spirit of kindness and helpfulness toward all. What he is and what he does have far more influence on his students than he is apt to realize.

I once knew a teacher who, on the first day of class, gave this fearful warning of things to come: "There are twenty-five students in this class, but about twenty-five percent of you probably will fail." A man who can make such a statement to his class is unfit to be a teacher. Such a person is building up his own ego at the expense of the twenty-five hopeful and generally well-meaning students. Even though his prediction be a correct one, he has demonstrated an inexcusable lack of tact and consideration for others. In addition, he has shown a simple ignorance of practical educational psychology, for this is not the way to get the most

(Continued on page 18)

TECHNICAL DRAWING

Second Edition

By **GIESECKE, MITCHELL and SPENCER**

This engineering drawing book has taken its place as a leading text in the field. The second edition is distinguished for its clear and full explanations, superb drawings and excellent problems. There is new material on shop practices, expanded chapters on the geometry of technical drawing, intersections and developments, dimensioning and fasteners. Instruments and materials, instrumental drawing, lettering, multi-view projections and pictorial drawing are treated with unique fullness and clarity. \$3.75

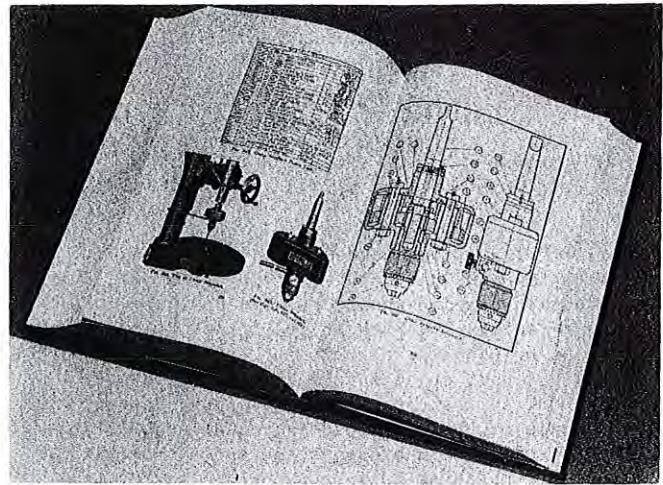

TECHNICAL DRAWING PROBLEMS *Revised Edition*

By **GIESECKE, MITCHELL and SPENCER**

The drawing fundamentals are covered more thoroughly and more comprehensively in the new edition of this workbook. There are now 105 rather than 93 sheets offering more advanced types of problems with increased emphasis on practical drafting room problems. Complete exercises in both vertical and oblique lettering are included in this manual in addition to problems on the other fundamental aspects of technical drawing. \$2.75

LETTERING EXERCISES are also available separately. Set, \$1.10

AIRCRAFT DRAFTING

By

HYMAN H. KATZ,
Allied School of Mechanical Trades, Inc. Formerly Supervisor of Engineering Training, Republic Aviation Corporation

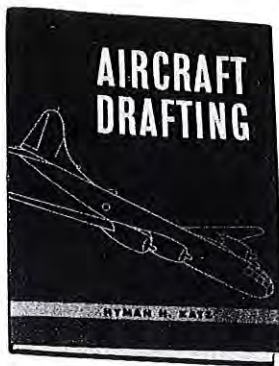

This book includes much practical information useful to the aircraft draftsman in addition to full training in the essentials of technical drawing and their application to aircraft. Considerable information is included on aircraft design, lofting techniques and processes, change groups, bills of materials, and weight calculations. Pictorial drawing, now widely used in industry and particularly in aircraft drafting, is stressed. Wherever possible, illustrations are used in place of lengthy explanations. \$5.00

THE BLUEPRINT LANGUAGE

By **HENRY C. SPENCER,** *Chairman of the Technical Drawing Dept., Illinois Institute of Technology and*

H. E. GRANT, *Associate Professor and Chairman of the Department of Engineering Drawing, Washington University*

This new combination text and workbook provides an unusually complete and realistic training in the essentials of blueprint reading for the machine industries. Over 100 major industrial companies have cooperated with the authors in the development of problems and illustrative material toward making *The Blueprint Language* meet the practical requirements of industry. Emphasis is placed on the visualization of machine parts and their uses. The book contains extensive chapters on shape description, including views of objects; normal, inclined, oblique, and cylindrical surfaces and edges; and sectional and auxiliary views. There is a whole section on modern shop processes. \$5.00

REPORT OF THE S.P.E.E. DRAWING AND DESCRIPTIVE GEOMETRY DIVISION COMMITTEE ON NOTATION AND NOMENCLATURE FOR DESCRIPTIVE GEOMETRY

Occasionally a good student desires to consult other texts than the one being used in his classes, in order to obtain a wider knowledge of descriptive geometry, or a familiarity with the text book field in anticipation of becoming a teacher of the subject. Occasionally a poor student asks his instructor for reference work so that he may improve his standing, which he feels or has been told is unstable. The instructor himself should of course be acquainted with many authors if he cares to increase his stock of problem material and to discover as many approaches as possible to the teaching aspect. All three of these desirable, even if rare, incidents are considerably discouraged, and the first two are definitely prohibited, by the fact that scarcely any two texts employ like methods of notation.

Even a superficial inspection of a random selection of treatises on descriptive geometry reveals an appallingly wide variation in the systems of notation used. There are some differences even in the terms used for space concepts, and few agreements on the symbols employed in marking their representations in the drawings. Admittedly, these symbols are only an accessory to the real purpose and meaning of a drawing, and so one system would perhaps serve as well as another. In only a few places can weighty arguments be offered against some one system or in support of another. However, the persistence of such a situation, in which the total textbook presentation of an exact science is so decidedly unscientific, is cause for apology and regret.

The recently devised standards in engineering drawing will well-nigh put an end in a few years, when the profession is filled by men trained since their adoption, to much temporary confusion occurring in drafting rooms until the neophyte has unlearned many of the things taught him in college. The use of a uniform notation and nomenclature in descriptive geometry would prevent like, though lesser, difficulties arising when two engineers, who have learned different systems for marking their drawings, try to discuss methods of solution of any problem which involves the use of descriptive geometry. Whatever misunderstanding may be encountered, it springs from the fact that they speak, or write, different dialects. It requires some time for them to "become acquainted".

The universal use of a single notation will make possible the administering of standard achievement tests in descriptive geometry, a project that has been proposed in the deliberations of this Division, but which has never been attempted for the simple reason that no list of problems or questions would be equally intelligible to students from different colleges who might be given the test. They could have fairly equal ability, and could possess an equal degree of training in the subject, and yet, because of unequal degrees of familiarity with the notation used on the problem sheets, might accomplish results that would be wholly unreliable. A translation of the questions into the language of each school represented would have to be

made, incurring the difficulty of establishing valid controls to insure uniform meaning.

In order to establish at least a beginning toward the correction of this unfortunate situation, the Division of Drawing and Descriptive Geometry, at the Cincinnati meeting in 1944, authorized the appointment of a committee to formulate a standard system of notation and nomenclature for descriptive geometry. The committee, because of the wide geographical separation of its members, has been compelled to do most of its work by correspondence, and was able to meet only once. Adoption by the Division of their recommendations will be assurance of time profitably spent. As with the work that resulted in the adoption of standards for drawing, so here it is our belief that the preparation of satisfactory standards for descriptive geometry must be a process of growth, and that a subsequent committee should now take over the work and extend the standards to cover the terminology and notation employed in all phases of drawing and applied descriptive geometry operations--the various types of pictorial drawing; shades and shadows; representation and intersections of surfaces; aeronautical, mining and structural applications; etc.

The committee began its work by agreeing upon several fundamental principles as a basis of deciding the terms to be included in a set of standards. It was obvious that they should be as simple and unambiguous as possible. Also, they should be adequate for all situations that may arise. And it was thought that if only a few of the fundamental, most-used items could be fixed, they would serve as the foundation of a more complete system.

The committee felt that up to the minute ideas on unifying notation, as well as authentic current usage by the authors, could best be obtained by means of a questionnaire. Consequently a list of questions was prepared and sent to all contemporary authors, about half of whom promptly responded. Letters were received from several stating they had been out of the descriptive geometry field so long that they did not feel their judgment should affect present day practice, and so did not register their systems of notation.

When the data desired were all in, tabulation was made on one sheet so that by running down each column the various symbols used by all the authors for representing any one item were readily discernible. This at least revealed if there is at present any preponderant agreement at any point among writers, and as well, told where the greatest diversions exist. In the main the committee was influenced by any existing majority of preference as expressed by the answers to the questionnaires. Exceptions to this procedure are mentioned in the detailed report below. It will be observed that in several instances more than one way of marking is recommended as being about equally satisfactory. If the Division prefers, your committee is prepared to reduce these to a single choice.

The visual results of the application of many elements of the proposed unified system of notation are seen on the printed sheet in your hands. For the presentation of all the terms recommended, the questionnaire referred to above is here repeated item by item in question-answer form, together with whatever explanatory discussion is necessary. Preliminary to this, two terms will be defined, before assigning names to the entities involved:

A Reference Plane, or Co-ordinate Plane, is a plane of unlimited extent to which a magnitude is referred in order to stipulate exactly the latter's position in space. In three-dimensional space an object can be specifically located if its position with reference to three mutually perpendicular planes be stated.

A Plane of Projection is a plane of unlimited extent upon which a particular view of a magnitude may be projected. An object in three-dimensional space can be completely represented by views drawn upon three mutually perpendicular planes of projection.

* * * * *

1. WHAT NAMES DO YOU ASSIGN TO THE THREE SO-CALLED PLANES OF PROJECTION?

Whichever of the two functions above are served by these planes, the names used for them will be as follows:

(a) The plane from which the above-below measurement is made will be known as the Horizontal, or xz, plane.

(b) The plane from which the front-rear measurement is made will be known as the Frontal, Vertical, or xy, plane.

(c) The plane from which the left-right measurement is made will be known as the Profile, or yz, plane.

These three planes are known as the three principal co-ordinate planes.

Many teachers of descriptive geometry have long felt that, while the name Horizontal unmistakably identifies the one co-ordinate plane, the names of the other two, Vertical and Profile although used almost universally in text books, are a source of confusion to the beginning student for the reason that both are vertical. The continued employment of the name Vertical as applied to one of the reference planes has descended through practically all works on the subject since its introduction by Monge, in whose immortal treatise it was quite intelligible, since only two planes were ever employed. In 1904 a text appeared* which, in order to avoid the indefinite name Vertical, while also employing a plane on which to draw a side view, used the qualifying adjectives, front and side, and calling them both Vertical. Thus, one became Front Vertical and the other Side Vertical. It seems practicable to contract the adjective and noun into the one word Frontal. The committee therefore recommends its selection for our standards, as well for the ending of the confusion mentioned above as for the fact that the etymology of the word connotes the plane upon which the front view is drawn. The side plane would continue to be the Profile plane.

2. BY WHAT LETTER, NUMBER OR SYMBOL RESPECTIVELY DO YOU DESIGNATE EACH?

The three planes will be designated by the initial letters of the words, in capitals -- H; F or V; P.

3. BY WHAT LETTER, NUMERAL OR SYMBOL DO YOU DESIGNATE THE INTERSECTION OF THE H AND F PLANES: H AND P: F AND P?

The intersection of the H and F planes is called the HF or x axis.

The intersection of the F and P planes is called the FP or y axis.

The intersection of the H and P planes is called the HP or z axis.

4. BY WHAT TERMS OR SYMBOLS DO YOU DESIGNATE THE COMPARTMENTS INTO WHICH THESE PLANES DIVIDE THREE-DIMENSIONAL SPACE?

The Frontal and Horizontal planes divide all space into four quadrants. The three planes divide all space into eight octants.

5. IF YOU CONSIDER THESE PLANES AS CONSTITUTING A CO-ORDINATE SYSTEM, TO TIE THE SUBJECT OF GRAPHICS IN WITH ANALYTIC GEOMETRY, HOW DO YOU ARRANGE THE CO-ORDINATE AXES?

See answer to question 3 above.

6. HOW DO YOU VERBALLY SPECIFY A POINT IN SPACE SO THAT ITS LOCATION IS UNMISTAKABLE?

A point in space may be located by any of the accepted methods, encountered in engineering problems, including

(a) Stating distances from reference planes.

(b) Stating distances from some other fixed point or points.

(c) Intersection of two lines.

(d) Intersection of three surfaces.

(e) Intersection of a line and a surface.

It may be specified mathematically by

(a) Cartesian co-ordinates.

(b) Equations of three surfaces.

7. BY WHAT LETTER OR SYMBOL DO YOU SPEAK OF A POINT IN SPACE?

A point in space may be referred to by a letter or by a numeral.

8. IF BY A LETTER, DO YOU USE A CAPITAL OR LOWER CASE LETTER?

A capital letter should be used.

9. HOW DO YOU MARK THE PROJECTION OF A POINT ON EACH OF THE PLANES OF PROJECTION?

The views or projections, upon the various planes of projection, of a point in space, say the point A, should be marked as follows: For the front view, it will be a lower case a, with a superscript F or V. For the top view, it will be a lower case a, with a superscript H. For the side view, it will be a lower case a, with a superscript P.

10. IF A POINT IS PROJECTED UPON THE HORIZONTAL PLANE, DO YOU CALL THIS PROJECTION THE TOP VIEW, THE

* James A. Moyer, "Engineering Descriptive Geometry"

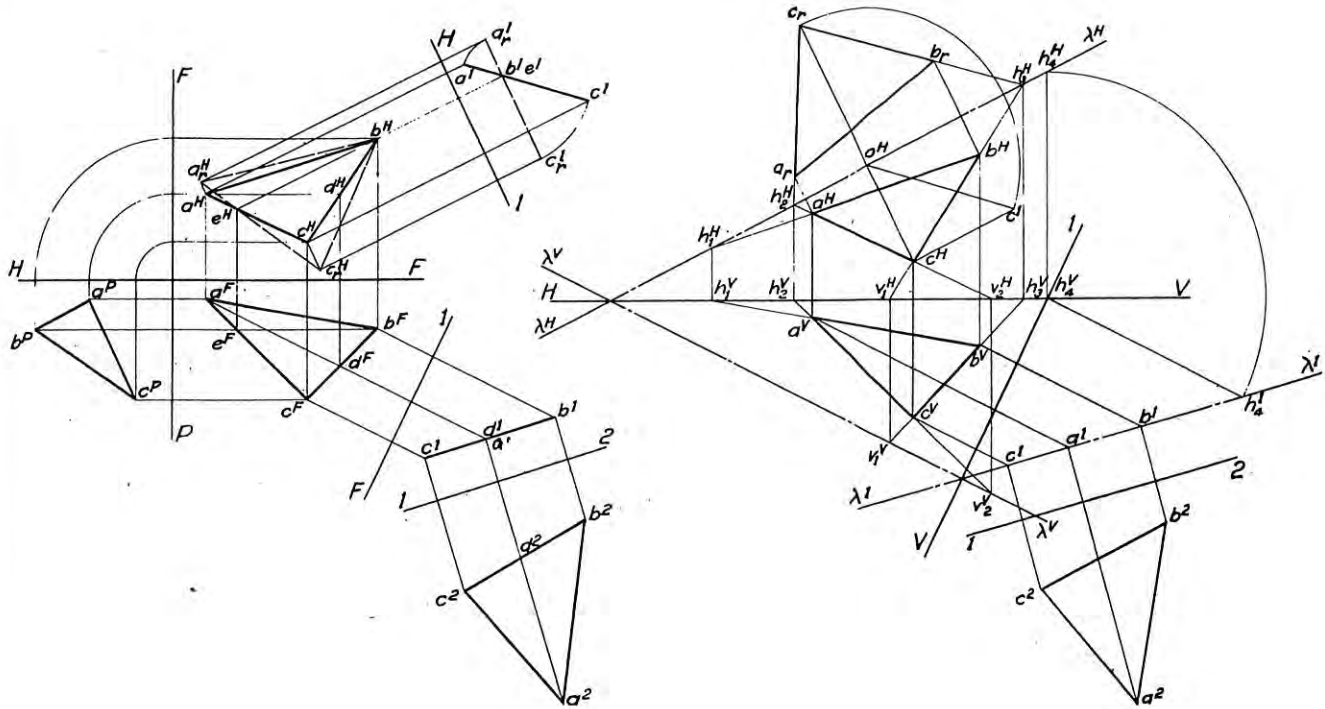

SYSTEM OF NOTATION FOR DESCRIPTIVE GEOMETRY
 PROPOSED BY THE COMMITTEE ON
 STANDARD NOTATION AND NOMENCLATURE
 FOR THE DRAWING DIVISION OF
 THE S. P. E. E.

HORIZONTAL PROJECTION, THE PLAN, OR ALL OF THESE INDISCRIMINATELY, OR SOMETHING ELSE?

The projection on the Horizontal plane may be called by all the suggested terms indiscriminately.

11. WHAT DO YOU CALL THE PROJECTION OF A POINT ON EACH OF THE OTHER TWO SO-CALLED PLANES OF PROJECTION?

On the Frontal or Vertical plane, the projection may be called the Front View, the Front Elevation, the Frontal Projection, or the Vertical Projection.

On the Profile plane the projection may be called the Profile View, Profile Projection, or Right and Left Side Views.

12. IF A POINT IS PROJECTED ON A PLANE OTHER THAN THE THREE PRINCIPAL PLANES OF PROJECTION, WHAT DO YOU CALL THIS PLANE?

(a) Planes other than the three principal planes, when used as planes of projection, are called auxiliary planes. The first one used is

known as auxiliary plane 1. The next, as auxiliary plane 2, etc.

(b) If more than one be employed in a series in a given problem, they are called successive auxiliary planes.

13. WHAT NAME DO YOU USE IN SPEAKING OF THE PROJECTION?

(a) The projection of a magnitude upon an auxiliary plane is called an auxiliary view or auxiliary projection.

(b) If more than one auxiliary plane be employed in a series in a given problem, the views are termed successive auxiliary views or successive auxiliary projections.

14. BY WHAT NOTATION DO YOU MARK THE PROJECTION?

(a) The projection of a point A upon auxiliary plane 1 is marked with a lower case a, accompanied by a superscript 1.

(Continued on page 24)

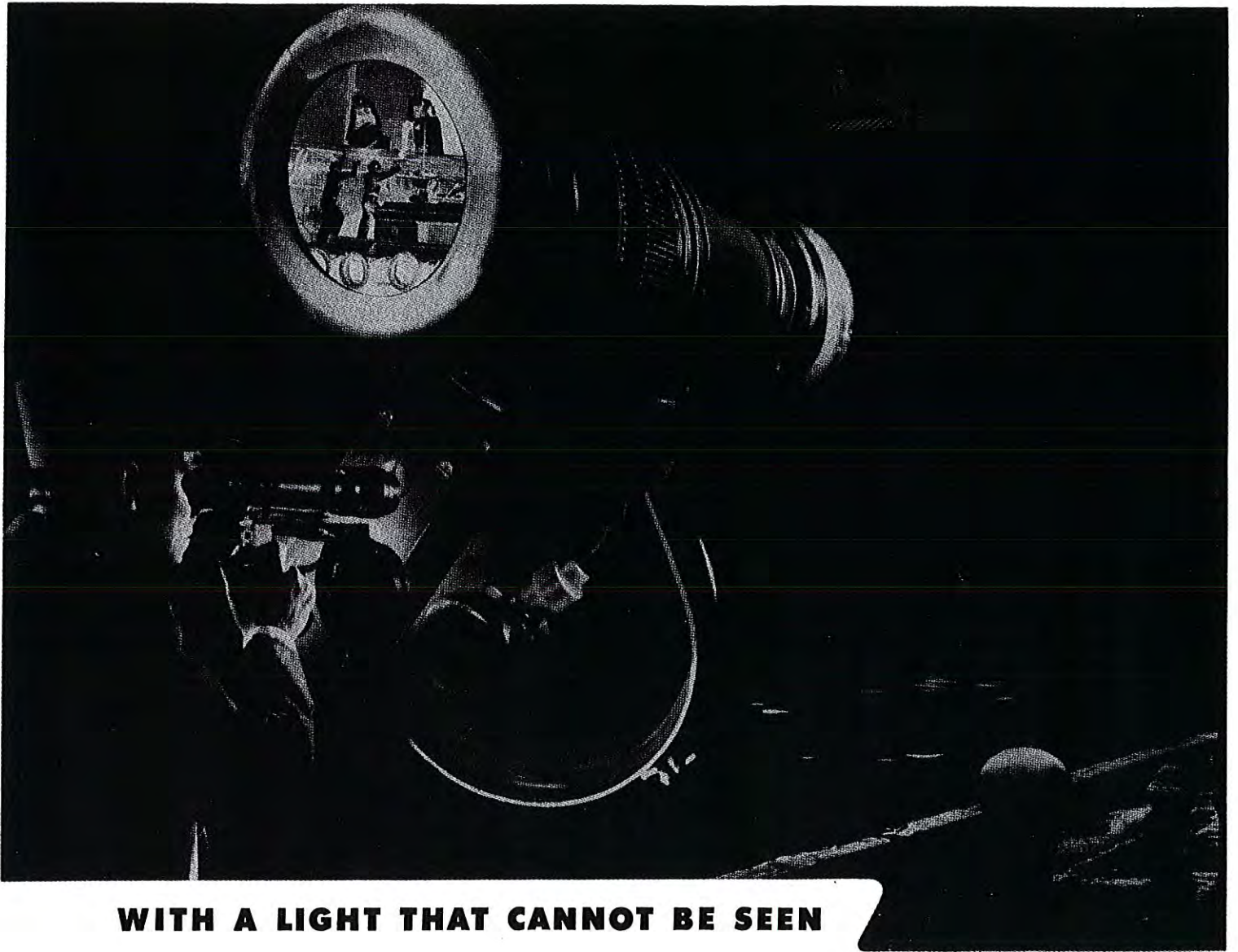

WITH A LIGHT THAT CANNOT BE SEEN

Photo courtesy Radio Corporation of America

AMERICAN SOLDIERS in pitch dark able to see clearly the enemy ahead; scout cars speeding at 50 miles an hour along blacked out roads in perfect safety; officers of the law seeing clearly the operations of hijackers "hidden" by night: these are some of the miracles performed with the help of the infrared telescope. Workers in the dark are thus aided by a light that cannot be seen.

It can be said that young lads, on the way to take their place in the world, possessed of hungers for they know not what, driven by innate energies they know not where . . . are just as truly working in the dark. And so, too, educators must illuminate the obscure face of the future for them . . . using a light that cannot be seen, the light of searching and sympathetic wisdom. Only then can a boy establish a goal that is socially useful and a personal recompense. Only thus can stumbling feet be kept on the road.

And how can the educator's responsibility be discharged, how can the unseen light be effectively used, if not with and through the familiar things of school routine? For example, the drawing instruments a youngster will use when he comes to mechanical drawing class . . . their very

selection can be an opportunity which gives a momentary glimpse into the beyond. These are tools of engineering, and engineering is the great hero of today and tomorrow. Shall its very instrumentality be chosen carelessly, treated with equal disregard? Or can the fact of great achievement be reflected into the life of the youngsters by a beautiful set, an exquisitely wrought set, a set to proudly possess the rest of the student's life . . . a set that may well be a touchstone, the source of another light that may also help to lead the lad onward and forever upward? Upon the right selection here vital values rest.

EUGENE DIETZGEN CO.

Chicago · New York · San Francisco · New Orleans · Pittsburgh
 Los Angeles · Philadelphia · Washington · Milwaukee
Dealers in All Principal Cities

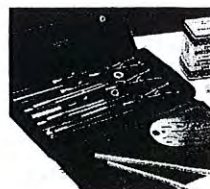

DIETZGEN

EVERYTHING FOR
 DRAFTING AND SURVEYING

**AMERICAN SOCIETY FOR ENGINEERING EDUCATION
ENGINEERING DRAWING DIVISION**

Minneapolis, Minnesota

June 17-21, 1947

by

O. W. Potter, Secretary
University of Minnesota

The 55th annual meeting of the American Society for Engineering Education was held June 17 to 21 at the University of Minnesota, Minneapolis, Minnesota. The convention headquarters was at the Nicollet Hotel but many of the meetings and luncheons were held on the campus of the University.

The Engineering Drawing Division had a full program as usual and a good attendance from all over the country. The meetings were presided over by our very able chairman, J. T. Rule of M. I. T. The program for the sessions is as follows:

Wednesday, June 18th. J. T. Rule,
Chairman, presiding.

10:00 A.M. Committee Meetings.

1:30 P.M. Technical Session. Fine Arts Room, Coffman Union.

Welcome to Minnesota.

R. W. French, University of Minn.
Analytical Procedure in Aircraft Design.

R. W. Holmes, Curtis Wright Corp., Columbus, Ohio.
Descriptive Geometry of Crystallography.

H. T. Evans, Massachusetts Institute of Tech.

6:00 P.M. Dinner Meeting. Ball Room, Nicollet Hotel.

Thursday, June 19th. R. T. Rule,
Chairman, presiding.

12:15 P.M. Luncheon Meeting, Terrace, Nicollet Hotel.

4:00 P.M. Executive Committee Meeting. Nicollet Hotel.

Friday, June 20th. J. T. Rule, Chairman,
presiding.

2:00 P.M. Technical Session. Fine Arts Room, Coffman Union.
Method of presenting Dimensioning.
Paul Machovino, Ohio State University.

Decimal System-Its use in the Aeronautical Industries and its Relation to Education.

P. J. Hayes, Jr., American Air Lines.

Report of Committees.

Motion Pictures for Teaching Engineering Drawing.

McGraw-Hill Book Co., Inc.

About 100 persons (members, friends and their wives) attended the division dinner on

Wednesday evening. The assigned speaker of the evening was unable to be present so Mr. Harry Peterson, President of the Control Corporation acted as pinch hitter.

Mr. Peterson was formerly a member of the Drawing department staff of the University of Minnesota. Mr. Peterson's talk was a sort of travelog. It was humorous and entertaining and put everyone in a good frame of mind for the more serious meetings that were to follow.

At the luncheon on Thursday there were 67 present. Dean Sherwood of M.I.T. was the speaker. The speaker pointed out some of the cultural side in the field of graphics in contrast to the purely utilitarian side. At this meeting the following officers were elected:

Chairman: F. A. Heacock, Princeton University.

Secretary: O. W. Potter, University of Minnesota.

Member of the Executive Committee, 5 years: J. G. McGuire, Texas A & M. Editor of the T Square Page: A. B. Wood, University of Tenn.

Journal of Engineering Drawing.

Editor: T. T. Aakhus, University of Nebraska.

Advertising Manager: J. N. Wood, Kansas State College.

Circulation Manager: R. T. Northrup, Wayne University.

Four very excellent papers were presented and we will all be looking forward to seeing them in print so that we can give them more careful study. The paper on the use of Descriptive Geometry in Crystallography was no doubt an eye-opener to many. The delicate subject of dimensioning was very well handled and set forth many worthwhile suggestions in teaching dimensioning. The paper on the use of decimal dimensioning set forth many of the advantages of such a system and urged a more widespread use in all branches of engineering. The motion pictures for teaching Engineering Drawing were the first of a series being prepared by McGraw-Hill Book Co., Inc. They were very good and offer another important aid to teaching Engineering Drawing.

It was another enjoyable time for those that could be present. The weather was clear and warm, typical summer weather. It was a time to renew acquaintances and meet new people in our field of work; I am sure it was a profitable time for all of us.

NEW FALL BOOKS FOR YOUR CLASSES

ENGINEERING DRAWING PROBLEMS

By

ELIOT F. TOZER and EUGENE PARÉ

Northeastern University

Illinois

Institute of Technology

THESE splendid problems, developed at Northeastern University and Illinois Institute of Technology will give your students a background for advanced courses such as Machine Drawing, Machine Design and Structural Drafting.

FEATURES:

- Brief problem statements
- Practical Problems
- Large sheets
- Graphic fundamentals conform to modern American Standards
- Blank sheets for the assignment of extra problems
- Inclusion of important sections of modern American Standards.

160 pages

11 x 17

Paper

Illustrated

\$3.25

ENGINEERING DESCRIPTIVE GEOMETRY PROBLEMS

SERIES B

By

C. E. ROWE and J. D. McFARLAND

University of Texas

TO alternate with the eminently successful Series A we now offer Series B as a boon to every descriptive geometry teacher. Time saving, compact, each problem sheet gives a stimulating support to any good descriptive geometry text.

FEATURES:

- New
- Fresh
- Minimizes reading mistakes
- Ample space in which to work out problems
- No overlapping of views
- Emphasis on practical aspects.

111 pages

8½ x 11

Loose Leaf Binding

\$2.50

Write for examination copies

D. VAN NOSTRAND COMPANY, Inc.

250 FOURTH AVENUE

NEW YORK 3, N. Y.

DEVELOPING RESPONSIBILITY AND INITIATIVE IN STUDENTS THROUGH TEACHING LETTERING AND SKETCHING

by

George J. Hood, Retired as Professor of
Engineering Drawing, University of Kansas

The plan here outlined for teaching lettering and sketching, if applied as suggested, will give each student greater faith in his own ability. The student also will learn to take the responsibility of making decisions, and of acting on them. This is a long step forward in his education. Teachers who try this method likely will be astonished at the high quality of the lettering, and at the uniformity in style throughout the class.

The procedure is so simple that some teachers likely will not believe it workable. But this method has been used in teaching lettering and sketching to hundreds of students. It has been proven over and over again that students have good judgment in proportioning letters and sketches, and that they will use this judgment if required to do so. All copy work is avoided. Lecturing and help by the teacher is purposely kept to a minimum. The student, rather than the teacher, receives the education.

For lettering the procedure is as follows: The students in the class are told to open their books at the page showing the upper-case vertical alphabet. The teacher explains that these are the simplest possible letters. And since these letters are so simple, they are most exacting in form and proportion. Penciling these letters is a job for an artist. It is necessary to use the eyes, and to place each line exactly where judgment dictates. All mechanical measurements and methods must be avoided.

The books are now turned upside down. Attention is called to the difference in width of the top and bottom of several of the letters. This difference is necessary for stability. Letters should not appear top heavy. The book is then turned right side up. Attention is called to the fact that the capital 'E' will not have the best appearance if made by adding a bottom line to the 'F', even though many assume this to be so. Also, the 'tongue' of the 'F' should be longer and lower than that of the 'E'. Each letter requires individual designing. The teacher has said enough. He should here check himself, and say nothing about the rest of the letters. Limiting explanations is the key to the successful use of this method. Make the student use his judgment. The books are now closed and put away in the lockers.

The students are provided with paper ruled with top and bottom guide lines only, about three-eighths of an inch apart. The students are told to make a single alphabet and a set of figures in pencil only. The letters and figures are to be vertical, and each letter is to be satisfactory to the student before he proceeds with the next. Each line is to be made with a single stroke of the pencil and, in general, the left-hand stroke of each letter is to be made first. The student

must use his own eyes, and he must be highly critical of each stroke and of every letter. Now go to it.

The teacher is now out of a job. He leaves the students entirely alone, stays away from their desks, and offers no suggestions. This is basic. Here, the teacher may have to change his habits radically.

Soon, some student brings an alphabet and a set of figures for approval to the teacher. The teacher may say: "Now look at that. You know that is not a good job. Go back to your desk, and don't show me your plate again until your judgment tells you that every letter is just right."

Later, another student comes to the teacher: "There are a few letters or figures that are not quite right." The student wants to know which ones. "Use your own eyes and judgment," he is told. If the teacher weakens at this point and makes a single suggestion regarding some detail, he undermines the plan, and soon many of the students will be leaning on him, instead of learning to depend upon themselves.

Before long, excellent work is brought to the teacher. The student is told to make four or five more alphabets and sets of figures as good or better than the first. When the penciling is satisfactory, one or more of the alphabets may be inked.

The same plan is continued with slant letters and figures, and with lower-case letters. The student may be allowed to study the sample alphabet in the textbook for a minute or two, and he then puts the book out of sight. The instructor says little or nothing.

It is strongly recommended that but two guide lines be used for all letters. Lettering becomes too mechanical when more than two guide lines are used. The student soon recognizes that the lower-case 't' is shorter than 'l', and he knows when the tail of the 'g' is too long or too short. Nearly all alphabets shown in textbooks may be improved by changing details here and there. The student soon becomes highly critical of alphabets shown in textbooks. All copying from samples should be entirely avoided.

When the time comes to letter sentences, the following procedure secures rapid improvement. Certain paragraphs of the textbook, printed in normal type, are specified to be lettered. Ruled paper is provided with only two printed guide lines. These are the upper and the lower guide lines for the lower-case 'a'.

The students are told to letter one line on the drawing paper, and then are to wait for additional instruction. The instructor stays away from the desks.

MID-WINTER MEETING

THE DIVISION OF
ENGINEERING DRAWING AND DESCRIPTIVE GEOMETRY

TIME: 2 P.M., SATURDAY, DECEMBER 27, 1947

PLACE: HORACE H. RACKHAM FOUNDATION BLDG., DETROIT, MICH.

Chairman of Arrangements: Professor Ralph T. Northrup,
Wayne University, Detroit 2, Mich.

PLAN TO ATTEND! Please notify Professor Northrup if you decide to attend the evening dinner meeting. An interesting program and plans for the next annual meeting are on the agenda.

When he observes that several students have quit lettering, he asks all students to stop whether or not they have completed the line. Without even looking at the work of the students, the instructor tells them that he knows that the letters are too far apart in the words. Each word should read as a unit, and adjacent words should be properly spaced, not too far apart and not too close. The students are then told to letter the second line, beginning with the next word of the text.

The instructor does not even look at the work of the students, but continues the same general procedure one line at a time. For the lines after the second, the following suggestions may be made for the improvement for each succeeding line: (3) "When making your letters closer together, you likely crowded the letters too much and have made the letters too narrow. In the next line make the letters broader." (4) "Now choose the best width and make the letters and words of uniform style. Also, make every stroke a uniform gray in color." (5) "Now sharpen your pencil, and make every letter just right and clean cut." Students who have not completed any of the lines soon realize that they are slow.

The experience of the instructor will tell him if other suggestions should be made to the class as a whole. Up to this point the instructor has not looked at a single plate. He now makes the rounds of the class, and suggests improvements in general terms here and there. As soon as a student produces first class work, he is told to letter three or four more lines fully as good or better than his best sample. When satisfactory, each plate is O.K.'d., and the plate is ready for inking. Nothing is gained by inking the poorer lines. It is well to leave one of the best lines in pencil.

The student makes remarkable progress in lettering sentences when the method just outlines is followed, and all within the time required to letter but five or six lines. The student notes the improvement in quality from line to line.

The procedure outlined above has been tried out with many students. The result is fine lettering throughout the classes. The artistic judgment of practically every student is found to be good if he is required to use that judgment. The student, who is not copying samples made by some one else, regards the result as his own. He finds greater satisfaction in doing the work, and he gains faith in his own ability. The teacher should remain in the background.

It seems worth while to take a sample of the student's lettering when he first enters the class: "This is a fair sample of my freehand lettering at this date. I have (or have not) had previous training in lettering." Name of high school, date, and signature of student. The students find much amusement when these first samples are handed back to them after the course in lettering is completed. They are then asked to letter the same statement in their improved style. The contrast is striking.

For orthographic and for perspective sketching from models, the usual practice is to have the model directly before the student while it is sketched. Believe it or not, the sketches will be much better proportioned and will look more nearly like the model if the students are shown the model for but a short time, and the sketches are then made after the model is put out of sight. The student is on his own. This increases his enjoyment and the quality of his work. For complicated models, it may be necessary to allow additional viewing of the model for the observation of the smaller details, but this should be permitted only after the general shape of the model has been sketched.

The writer would be glad to hear from any teachers who are willing to break with old customs sufficiently to give the above described method a trial.

PROBLEM SOLUTION

by

Professor John T. Rule
Massachusetts Institute of Technology

Given two planes P and Q and two random points A and B (not on opposite sides of either plane - this is a necessary condition for a solution to exist.) To find the radius and center of a sphere tangent to P and Q and containing A and B.

Analysis:-

1. Construct plane R (Fig. 1) bisecting the dihedral angle of P and Q (R is the locus of points equidistant from P and Q.)
2. Construct plane S perpendicular to the line AB at its midpoint, M, (S is the locus of points equidistant from A and B.)
3. Find the line of intersection of planes R and S, line OE. The center of the required sphere lies on this line.
4. Planes P, Q, R and S meet at a point O.
5. Construct planes W and W' containing OE and perpendicular to Q and P, respectively, intersecting Q and P in lines OF and OF'. (The points of tangency will be on OF and OF'.) Only W and F are shown in Fig. 1.
6. Draw OA and OB.

Since all the planes and the lines OA and OB meet at point O, point O is a center of similitude for this entire system.

Consequently:-

7. Choose any point such as C' on OE and draw C'T perpendicular to OF. With this as a radius construct a sphere having C' as its center. This sphere will intersect lines OA and OB at two points A' and B' such that A'B' is perpendicular to and bisected by plane S. (There will, in general, be two pairs of these points so that there are two solutions.)
8. Draw C'A'. To construct the similar and required sphere. Through A draw a line parallel to C'A' intersecting OE at point C.

Point C is the required center and CA is the required radius.

This problem does not always admit of a solution. If you assume two planes P and Q and one point, A, (Fig. 2 shows an edge view of these planes), all the possible spheres tangent to the two planes and passing through the point sweep out a space shaped somewhat like a lopsided torus.

The revolving circle varies in radius. The axis of revolution is a line thru A making equal angles with P and Q. The second point must lie inside the space so swept out. There will be two little hat shaped volumes labeled M, and the much larger enveloping volume labeled N which are taboo to the second point.

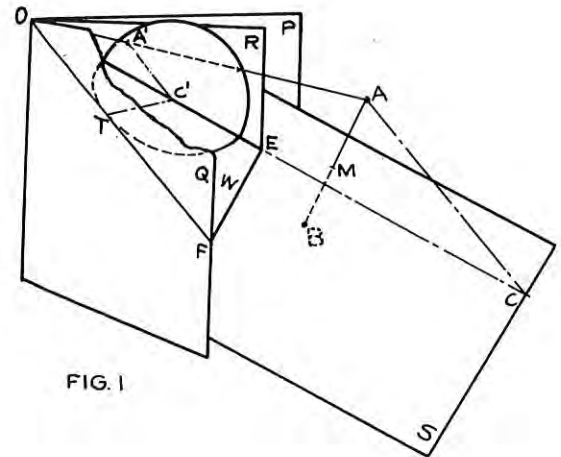

FIG. 1

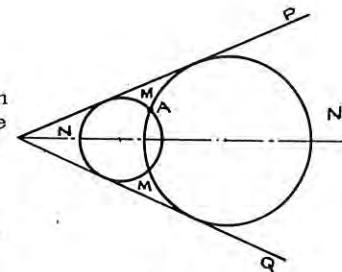

FIG. 2

SOLVE THIS ONE

Problem: Given two non-intersecting, non-parallel lines, and any plane. To construct a line of specified length terminating in the two given lines, and parallel to the plane.

This column is designed for the entertainment and improvement of those who enjoy putting descriptive geometry to work for the thing it is credited with doing best--training one in clear, logical and constructive thinking. It is open to contributions of progressive professors' pet personal puzzling problems. A year's free subscription to the Journal will be entered for the reader who first submits any problem accepted for publication. A correct solution shall accompany each problem offered.

A year's subscription is also presented the reader who submits, in time for publication in the ensuing issue, the best solution. If a drawing is required, one done in ink shall accompany it as copy for reproduction. All constructions must be Euclidean; that is, only straight edge and compass should be used.

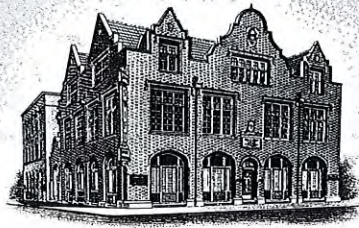

University Engineering Departments

USE THE

JOHN S. SWIFT CO., Inc. PLANOGRAPH PROCESS

FOR THE REPRODUCTION OF

DRAWING SHEETS



PROBLEM BOOKS



MECHANICAL DRAWINGS



MAPS—CHARTS



INSTRUCTION MATERIAL

Your Choice of Binding: LOOSE-LEAF, SEWED AND CASED, WIRE SPIRAL, PLASTIC, ETC.

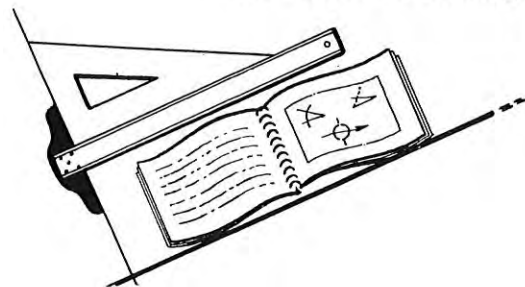

JOHN S. SWIFT CO., Inc.

OPERATING FIVE PLANTS

New York 1, NY
455 West 30th St
Lackawanna 4-1144

Chicago 7, Ill
17 N Loomis St
MONroe 7020

St Louis 3, Mo
2100 Locust St
CHestnut 7141

Cincinnati 2, O
3rd and Vine Sts
PARKway 4148

Cleveland 13, O
116 St Clair Ave, N W
PProspect 4488

(Continued from page 6)

from those students. The true teacher always encourages, never discourages, and is always ready to build up the student's confidence in his ability to do the work in hand by complimenting him on a job well done, and by using great tact in explaining what is wrong with work poorly done.

Grading is a powerful tool in the hands of the teacher, and his character is plainly shown in the way he exercises it. His grading should be as objective as possible, and when he grades a student down, his mark should be accompanied by reasons for the low mark. If no reasons are given, orally or in writing, the grade should be, logically, 100 per cent.

While grades on individual student efforts must, in the last analysis, depend upon the mature judgment of the teacher, the mechanics by which the grades are compiled, averaged, and adjusted, should be known and understood by all the students. The department head should see to it that his teachers grade drawings and examinations as uniformly as possible, and that all teachers calculate their grades in exactly the same way according to the system adopted by the department.

The character of the teacher is clearly shown by the manner in which he handles his class from a discipline standpoint. Since every student is a separate and distinct personality, all teachers will occasionally encounter "difficult" students. The true teacher is personally interested in each individual, and is sensitive to his reactions. He will quickly spot the student who has an unfriendly attitude, or an unhealthy viewpoint with respect to his work, and he will make a special effort to size a student and to anticipate his reactions. Almost invariably the student will respond to the teacher who is firm, but understanding, and who makes a special effort to show him that he has a friend who will give him a square deal.

A disorderly class naturally results when the teacher does not know his subject, does not make an earnest effort to help the students, or does not conduct himself with confidence, poise, and dignity. A quiet, business-like atmosphere results from a well-organized sequence of work in which the student believes he is doing something of importance in his engineering education, and of a control exercised by a teacher whom he likes and respects.

Students are reasonable creatures, and they resent a teacher who expects pin-drop order in the classroom, for they know very well that such austerity is unnecessary for the performance of the work to be done. On the other hand, students do not respect the teacher who, often out of a misguided notion of how to make students like him, allows bedlam to prevail in his classes. The great majority of students really want to learn, and they appreciate teachers who have definite and consistent ideas as to what constitutes a good working condition in the classroom. The teacher should take as his model the drafting room in industry. Here there is work to be done, and competent people in charge insist that everything be subordinated to getting the job done correctly and with a minimum waste of time.

The teacher's character shows itself in the degree of patience he has with his students. The poorer students are, of course, the butt of the ill-tempered teacher's disposition. I recall an example of this in a class in calculus. A certain boy was a C+ to a B- student in most of his work, and had little difficulty with mathematics until he was unfortunate enough to get in Prof. Blank's class. The professor was a brilliant mathematician, but it was difficult for him to appreciate the average student's difficulties with the mysteries of calculus. He was irascible and impatient with students who did not understand, apparently assuming that those who did not grasp the idea did so deliberately and maliciously just to make life unpleasant for him. This student finally exasperated Prof. Blank once too often, and he bluntly told the student before his classmates that he was "just too dumb to learn mathematics." This remark completely discouraged this fine lad, and he soon dropped out of class altogether. This so-called brilliant man was, of course, weak in human understanding, tact, and judgment, and should not have been allowed to teach at all.

I also recall another teacher, Prof. A. Mitchell, of Texas A & M College, who had all the fine qualities of character desired in a teacher. His outstanding characteristics were kindness and patience. During an engineering drawing class he would not retire to his table at the front of the room or to his office in order to grade papers or do other routine work, no matter how pressing those duties were. He would spend the entire time going from table to table, checking up on the students' progress, and frequently

sitting at the students' tables to demonstrate how the work should be done. If a student asked him a question, he would not say, "Read your textbook". Instead, he would say, "Let us see; I believe your text has something to say on that," and he would open the student's book and show the passage to him. This procedure did more to encourage the students to use their texts than any number of impatient or petulant retorts would have done.

Professor Mitchell was at his best in explaining a problem which was hard for the student to visualize. Any student, whether he was a member of his class or not, was always welcome, and between classes his office door was always open. First, he would explain the idea, slowly and painstakingly, with the aid of sketches or with models fashioned from anything at hand. Then, knowing that a student will often say he understands when in fact he does not, he would ask some simple question to find out. If the result was negative, he would then explain again, using a different approach, and this procedure would be repeated until both he and the student were satisfied. Above all, he would not give the impression that the student was stupid or in any way inadequate, nor would he allow the student to think he was taking too much of his time.

The character of the teacher is never more clearly demonstrated than in the way he cooperates with others engaged in the common task. The teacher, in joining the team, must recognize established lines of authority, and should sincerely and vigorously help to carry out departmental policies. If he feels that he has real ground for complaint, he should frankly carry the problem to the administration with a view to finding a solution which will be desirable to the group as a whole. If this is done in the right spirit, a satisfactory and permanent solution can usually be found. Failing this, he should seek employment elsewhere where the policies will be more to his liking. There can be no defense whatever for the dissatisfied teacher who secretly connives against and undercuts those who are the objects of his dislike.

Another time-honored but nevertheless important rule is "Don't wash your dirty linen in public." Translated, this means: "Do not discuss with outsiders things you don't like in your school or department". Such outsiders

wonder why you continue to be affiliated with such a group, and conclude more often than you think that there must be something wrong with you. Speak well of others if you wish others to think well of you. If you cannot speak well of a fellow-teacher, you had better say nothing at all.

Finally, a teacher deals primarily with human beings, and to be effective, he must have a good personality. Personality is a quality which seems to stem from both the heart and the mind, and it varies with every individual. A so-called "pleasing" personality is one which is warm with sincere interest in and consideration for others. A "vivid" personality is expressed in obvious enthusiasm for life. A "strong" or "dominating" personality exhibits self-assurance and qualities of leadership. The true teacher will have varying degrees of all of these. Personality cannot be as clearly determined as one's I.Q., but it is a very definite quality which can be appraised by others. All of us are constantly under observation, and our associates will get our number sooner or later. Eventually this general pattern of personality will become a matter of record, and will follow us everywhere we go.

In summary, the engineering drawing teacher should make up his mind that teaching is the finest work on earth for him, or he should, as soon as possible, withdraw from the profession and try something else. He should be primarily concerned with improving his own qualifications, and let remuneration take care of itself. He should, as soon as possible, complete his basic academic training, and then strive continuously to learn more about his specialty, engineering graphics. He should be eager to learn all he can about methods of teaching. He must keep up with the professional literature in his field and related fields, and maintain active participation in technical societies and contacts with industry. He must always keep before himself the high standards of character and of conduct required in his profession, and always remember that his goal is service to others. He should constantly strive to improve his methods of grading, of discipline, and class presentation, and to develop patience and understanding. Finally, he should be absolutely loyal to the organization of which he is a part, and do his utmost to further its high objectives.

TEACHING TOLERANCES

by

J. Gerardi and O. B. Noren
 Department of Engineering Drawing
 University of Detroit

In the preceding article of this series, accepted, standard methods of dimensioning were presented, and an attempt was made to show how that phase of engineering drawing might be introduced in existing courses.

In the teaching of tolerances and limit dimensioning, as in the teaching of the entire drawing field, one is continually confronted with situations which are correctly handled in a manner which does not conform to the basic rules.

No one well versed in limit dimensioning would ordinarily dimension a piece as shown in Fig. 1, because of the "stack-up" of tolerances which results from dimensioning the overall length and each of the component lengths. However, there are instances in which it is perfectly proper and expedient to dimension a piece as shown in Fig. 1.

Why is it true that this fundamental of dimensioning may be violated? What factors influence the situation to this extent? These questions can be answered directly - Manufacturing Method.

Fig. 2 is an assembly drawing containing the piece shown in Fig. 1. It illustrates an instance in which it is necessary that the overall length and each of its components be dimensioned and held within quite narrow limits. The piece is a double-flanged thrust bearing such as is used in almost all present-day automotive engines.

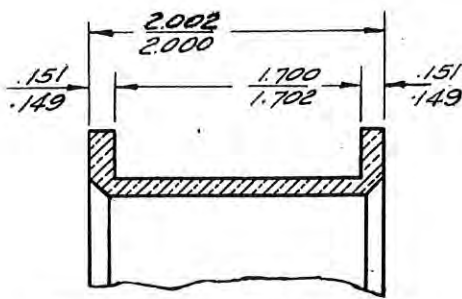

PARTIAL VIEW
 OF BEARING
 FIG. 1

Now where does manufacturing method enter the picture in a manner which necessitates this apparently impossible set of dimensions?

Experience dictates that the bearing must be positioned in such a way that axial movement is limited to a minimum. Simultaneously, crankshaft location and clearance between thrust collars and flange faces must be maintained. Therefore, the following condition must be met:

1. Narrow tolerance on the bearing saddle - standard practice is .002".
2. Minimum possibility of axial movement of the bearing - standard practice is Maximum saddle length $\pm .001$ " - minimum length between flanges, with tolerance of .002".
3. Minimum variation in overall length of the bearing, standard practice in passenger vehicle engines is .002".
4. Axial location of the crankshaft must be held within close limits. Therefore, uniform flanges are indicated - standard practice is .002" tolerance in flange thickness.

If all these conditions are to be met in a piece produced by modern mass production methods, it is neither satisfactory nor correct to dimension the drawing otherwise than as shown in Fig. 1, and here is where the manufacturing method enters the picture.

The length between flanges Fig. 1 (1.700"/1.702") is finished first by means of a lathe set-up using two tool bits properly spaced. Then the thrust faces are

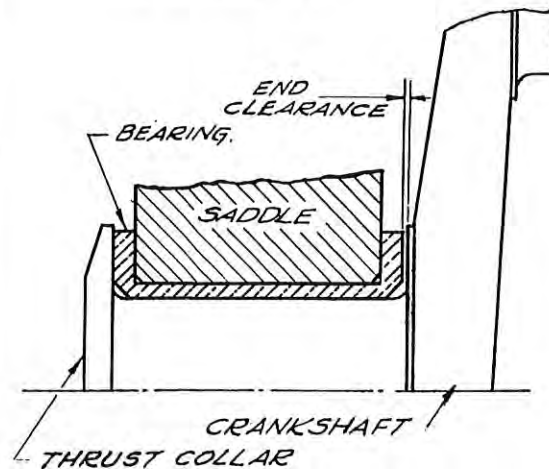

THRUST BEARING
 ASSEMBLY - FIG. 2.

finished simultaneously by straddle turning. This operation determines the overall length and the thickness of each flange.

(Continued on page 22)

Quality....



DRAWING MATERIALS

DRAWING INSTRUMENTS
IN SETS

DRAWING AND
TRACING PAPERS

WATERPROOF
DRAWING INKS



STUDIO, SCHOOL AND
DRAFTING ROOM FURNITURE

Catalogue, Vol. 700, on Request

F. WEBER CO.

FACTORY ADDRESS:
1220 BUTTONWOOD STREET
PHILADELPHIA, PA.

Branches:

705 PINE ST., ST. LOUIS, MO.
227 PARK AVE., BALTIMORE, MD.

(Continued from page 20)

The space between the tool bits is determined by a gauge set to the overall length Fig. 1 (2.002"/2.000"), and the thickness of each flange is controlled by moving the tool block parallel to the axis of the lathe. Uniformity of the two flanges is insured by frequent spot checking of the production pieces, necessary adjustments being made to hold nearly equal flange thicknesses. Thus, the manufacturing process involved overcomes what is an apparent obstacle in the way of manufacturing the required piece.

True, this is a specialized case, but it has been presented in some detail to emphasize the fact that the piece to be dimensioned must be analyzed from the point of view of manufacturing. The machining operations involved and their sequence are of great importance in determining the method of dimensioning and the tolerances which can be maintained.

It is not supposed that the general run of freshmen and sophomores can be taught, in their engineering drawing classes, all the material necessary to enable them to complete a satisfactory dimensional analysis

of even as simple a problem as the foregoing. However, it is most sincerely hoped and desired that students will be informed that dimensioning, including limit dimensioning, is strictly practical and functional. It is not governed by a series of hard and fast rules: it complies with no formula. Every job of dimensioning may be handled in diverse ways, many of which may be satisfactory. But no one can say that this method is right and that wrong until the actual, or hypothetical, manufacturing method has been outlined.

When the need for unusual dimensions arises in an assigned problem, it rests with the instructor not only to indicate that in a case of this kind it is better done this way, but also to present as detailed an explanation, as complete an analysis of the problem as is necessary to secure clarity of understanding in the mind of the student.

The succeeding article in this series will discuss the subject of surface roughness, what it is, its significance, and its methods of representation.

LETTER FROM H. C. T. EGGERS

To All Members of the Drawing Division of ASEE

Dear Fellow Members:

It was with extreme regret on my part that I was unable to be present at the June meeting of the Society in Minneapolis. Due to the fact that I was the host and it was up to me to welcome you and see that you were properly taken care of, you can well imagine my feelings as well as my embarrassment at not being able to fulfill my duties.

Since this was the first time in my life that I was seriously ill, all I can say is that old man "Percentage" sure picked a very inopportune time to do his dirty work.

I had looked forward for the entire past year with a great deal of pleasure and anticipation to meeting my friends again. Fortunately a few of the boys called at the house and it was a pleasure to greet them.

The flowers that the group sent to me were deeply appreciated and since it is not possible to thank each of you individually I am taking this means to do so collectively.

The doctors feel quite certain that I will be entirely recovered by the time classes start in the fall so I am already planning to greet you fellows personally at the National meeting next summer. Until next summer then, thanks for everything.

Sincerely,



Henry C. T. Eggers
Chairman, Department of
Drawing & Des. Geometry
University of Minnesota

DESCRIPTIVE GEOMETRY

By EARLE F. WATTS and JOHN T. RULE

This exceptionally lucid text describes thoroughly the methods of solving engineering problems by graphical means.

NOTE THESE OUTSTANDING FEATURES

- Emphasizes the solution of problems, stressing fundamentals.
- Includes the properties of plane figures as a proper part of a text on graphical means.
- Includes chapter on stereoscopic drawing (no other published work exists on this subject except articles in professional journals).
- Material logically developed, well organized.

Believing that all methods are a part of the subject, the authors do not believe in limiting the teaching of Descriptive Geometry to a single method. Their work is designed as a basic text in Descriptive Geometry, Engineering Drawing, or Graphics courses.



PROBLEMS IN DESCRIPTIVE GEOMETRY

By EARLE F. WATTS and ARTHUR L. GOODRICK

This helpful set of problems has been selected to illustrate fundamentals as set forth in DESCRIPTIVE GEOMETRY. Problems cover special methods which branch out from fundamental principles, and then go into the application of these methods. To aid the student in appreciating the precision obtainable in graphical methods, certain problems are included which require both a graphical and an analytical solution. A form for plotted problems is also included so that the instructor may assign problems of his own choice.

Send for Your Examination Copies Today

PRENTICE-HALL, Inc.

70 FIFTH AVENUE

NEW YORK 11

(Continued from page 10)

- (b) The projection of a point A upon the second auxiliary plane 2 is marked with a lower case a, accompanied by a superscript 2.
15. IF A POINT IS PROJECTED UPON A SEQUENCE OF AUXILIARY PLANES, HOW DO YOU DESIGNATE THE SUCCESSIVE PROJECTIONS?
- This has been answered in 13 and 14.
16. BY WHAT LETTER, NUMERAL OR SYMBOL DO YOU DESIGNATE THE INTERSECTION OF ANY AUXILIARY PLANE AND THE PLANE OF PROJECTION TO WHICH IT IS PERPENDICULAR?
- Near one end of this line is placed the letter or numeral corresponding to the name of one of the planes, and near the other end is placed the letter or numeral corresponding to the name of the second plane.
17. HOW DO YOU VERBALLY SPECIFY A LINE IN SPACE SO THAT ITS LOCATION AND DIRECTION ARE UNMISTAKABLE?
- A line in space may be located by any of the accepted methods encountered in engineering problems, including
- Locating two of its points (for a straight line).
 - Locating a point and specifying its direction.
 - Intersection of two surfaces.
- It may be specified mathematically by
- Cartesian co-ordinates of two of its points (for a straight line).
 - The co-ordinates of one point and direction, including direction angles, cosines, or numbers.
 - Equations of two surfaces.
18. BY WHAT LETTER, LETTERS OR SYMBOLS DO YOU DESIGNATE IT?
- The segment of a line is designated by two capital letters, one at each extremity, and the projections are marked by the customary notation for the two points.
19. IF A LINE IS GIVEN BY TWO POINTS, DO YOU CONSIDER THIS SUFFICIENT DESIGNATION?
- Yes.
20. HOW DO YOU VERBALLY SPECIFY A PLANE IN SPACE SO THAT ITS LOCATION AND INCLINATIONS TO THE REFERENCE PLANES ARE UNMISTAKABLE?
- A plane in space may be located by any of the accepted methods encountered in engineering problems including
- Specifying traces.
 - Specifying three of its points.
 - Specifying two of its lines.
 - Specifying a point and a line.
 - Specifying a point or line and the angles with the reference planes.
- It may be specified mathematically by
- An equation.
 - Intercepts.
21. WHAT LETTER OR OTHER SYMBOL DO YOU USE TO DESIGNATE A PLANE?
- A plane is named by a single capital letter other than H, F, V and P, preferably the later
- letters of the alphabet, as R, S, T, etc.; also by capital letters or numerals naming the points or lines in space which determine it. Capital Greek letters are approved as well as English.
22. WHAT DO YOU CALL THE INTERSECTIONS OF A PLANE AND THE PLANES OF PROJECTION, INCLUDING AUXILIARY CO-ORDINATE PLANES?
- They are called traces.
23. WHAT NOTATION DO YOU USE ON THESE INTERSECTIONS?
- The projection of a trace on the plane of projection in which it lies is marked at both ends with a lower case letter accompanied by a superscript capital letter or numeral appropriate to that plane of projection. The projection coincident with the "ground line" is not lettered.
24. WHAT NAME, IF ANY, DO YOU USE FOR THE LINE OF INTERSECTION OF ANY TWO PLANES OTHER THAN PLANES OF PROJECTION?
- Simply that--the line of intersection--marking it as any other line.
25. WHAT DO YOU CALL THE POINT OF INTERSECTION OF A LINE AND A PLANE OF PROJECTION?
- The point in which a line intersects a plane of projection is called the linetrace.
26. WHAT DO YOU MARK IT ON THE DRAWING?
- The line's H trace is a point H, and the projections of this point H are marked according to (9) above. For example, the three principal projections of the point H and h^H , h^F and h^P . Similar notation is used for the F trace and the P trace.
27. WHAT DO YOU CALL THE INTERSECTION OF A LINE AND ANY PLANE?
- The point in which a line intersects a general plane is called the piercing point, and is marked as any point.
28. WHAT SPECIAL NAMES DO YOU USE FOR LINES PARALLEL RESPECTIVELY TO THE THREE PLANES OF PROJECTION?
- Lines parallel respectively to the three planes of projection are called H-parallel; F-parallel or V-parallel; P-parallel.
29. WHAT SPECIAL NAMES DO YOU USE FOR PLANES PERPENDICULAR RESPECTIVELY TO THE THREE PLANES OF PROJECTION?
- Planes perpendicular respectively to the three planes of projection are called H-projecting plane; F-projecting plane or V-projecting plane; P-projecting plane.
30. IF A MAGNITUDE BE ROTATED TO A NEW POSITION ABOUT AN AXIS, WHAT DO YOU CALL THE SPACE OPERATION?
- The operation is called revolution, whether the magnitude be revolved into some special new position such as into a co-ordinate plane, if it is a plane figure, or merely turned about an axis through a specified angle.

(Continued on page 31)

17
NEW-POST WAR
CHARVOZ PRECISION
DRAWING SETS

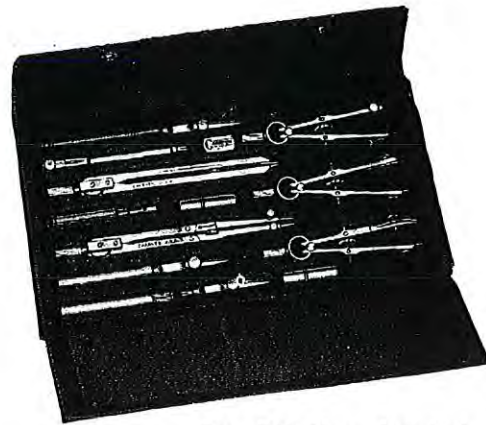

Charvoz No. 877 Drawing Set

SCHOLASTIC SETS To meet the post war needs of students in Technical Schools and Engineering Colleges.

PROFESSIONAL SETS To satisfy the exacting requirements of the Professional Draftsman, the Architect and the Engineer.

EACH SET A nice, appearing, highly polished, well balanced precision built set, attractively designed by Charvoz engineers. Produced at our Charvoz factories under high manufacturing standards and rigid methods of inspection.

EACH INSTRUMENT A sturdy well balanced precision instrument built for accuracy, perfect performance and life long service. Mechanically perfect and expertly constructed to make possible the finest precision work.

ALL SETS Nicely fitted in neat, compact, leatherette cases lined with velveteen. Each set neatly boxed in a new type, attractive, streamlined sturdy carton on which is clearly indicated the style and stock number.

Charvoz-Roos Corporation

101 FIFTH AVENUE

NEW YORK, N. Y.

Why the 4 Center Approximate Ellipse - Ellipses?

By

A.J. Philby

Department of Engineering Drawing
The Ohio State University

During a lecture on the ELLIPSE, one of my students was amazed at the ease with which an ellipse could be drawn by the 4 center approximate method. However it was my turn to be amazed when this student asked me why the construction used, established the four centers that determined the approximate ellipse. I frankly admitted I did not know, but that I would attempt to find the solution.

I was unable to find any proof in a number of geometry books, and the staff members I questioned did not recall having seen a solution to this problem. Assisted by Lloyd D. Yates of our department and Jay N. Edmondson of Industrial Engineering, I wish to present the following two solutions: the first by similar triangles, the second by trigonometry.

AB = 2.5
AO = 2.0
BO = 1.5

The 4 Center approx. construction is made first and then proved.

BC = AO - OB = 2 - 1.5 = .5
∴ AC = 2.5 - .5 = 2 and AD = DC = 1.0

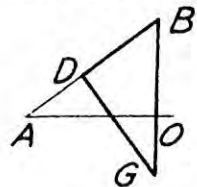
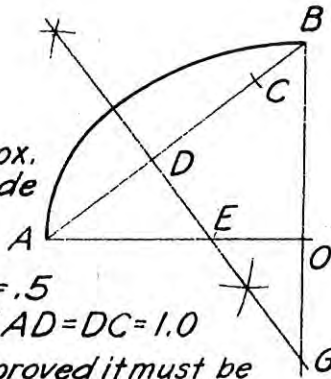

To be proved it must be shown that $AE + EG = BG$.
In the heavy triangle we have:
 $\angle GDB = \angle AOB$ $\angle GBD = \angle OBA$
 $BO = 1.5$ $BD = 1.5$ ∴ $BG = 2.5$
 $\triangle AED$ is similar to $\triangle AOB$
 $\angle DAE = \angle OAB$ $\angle ADE = \angle AOB$ etc.

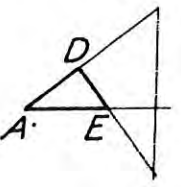

$AD = 1$ and $\frac{AD}{AO} = \frac{AE}{AB}$
 $AE = \frac{(1)(2.5)}{2} = 1.25$

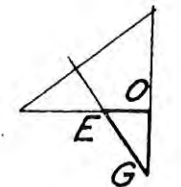

also $\triangle GOE$ is similar to $\triangle AOB$
 $OG = BG - BO = 2.5 - 1.5 = 1.0$
 $\frac{OG}{AO} = \frac{EG}{AB}$ $EG = \frac{(1)(2.5)}{2} = 1.25$
∴ $AE + EG = 1.25 + 1.25 = 2.5$

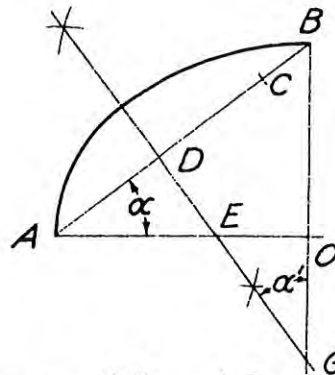

OB = 1.5
AO = 2.0
 $(OB)^2 + (AO)^2 = (AB)^2$
∴ $AB = 2.5$
 $BC = AO - OB$
 $BC = .5$
 $AC = 2$
 $AD = 1$ (DG is the \perp bisector of AC)

$\tan \alpha = \frac{OB}{AO}$ or $\frac{1.5}{2}$ or $.75$

$\sin \alpha = .6$ $\cos \alpha = .8$

$AE = \frac{AD}{\cos \alpha}$ or $\frac{1}{.8}$ or 1.25

$EO = AO - AE$ or $2 - 1.25$ or $EO = .75$

$OG = \frac{EO}{\tan \alpha}$ or $\frac{.75}{.75}$ or 1.0

$OB = 1.5$ ∴ $OG + OB = 2.5$

$EG = \frac{\tan \alpha'}{\sin \alpha'}$ or $\frac{.75}{.6}$ or 1.25

∴ $AE + EG = 2.5$

Then $AE + EG = OG + OB$.

Q.E.D.

COMMITTEE REPORTS

PROGRESS REPORT OF COMMITTEE ON ADVANCED CREDITS—DRAWING DIVISION ASEE
MINNEAPOLIS — JUNE, 1947

Following a resolution adopted by the Division at our meeting held in St. Louis in June, 1946, the chairman of the Drawing Division appointed a committee to prepare unit examinations covering all subjects treated in basic engineering drawing courses. This committee was organized about the time of our mid-winter meeting this year, held at the Brooklyn Polytechnic Institute. The chairman of this committee made some investigation regarding the possibility of handling these unit tests through a central agency before we held a meeting in Chicago. This committee met at the Shoreland Hotel, April 18 and 19, 1947. All the members of the committee were present. The committee is made up of the following members:

Professor W. M. Christman,
University of Wisconsin
Dr. Maurice Graney,
Purdue University
Dean R. P. Hoelscher,
University of Illinois
Professor John M. Russ,
University of Iowa
Professor Ralph S. Paffenbarger,
Ohio State University

Dr. Kenneth W. Vaughn, Director of the Measurement and Guidance Project in Engineering Education, 437 West 59th Street, New York, New York, was also present. Dr. Vaughn explained to the committee how his office might assist us in this project. The committee accepted his offer and have agreed to furnish finished copies of fifteen unit tests in experimental form for printing and distribution. The Measurement and Guidance Project Office will publish these tests. They are to bear the cost of production of the tests and charge a fee agreed upon by the Director of Project Office and the committee for the use of the tests. The tests will be semi-confidential in nature and will be distributed exclusively through the Project Office. The Project Office not only will have charge of the preparation and distribution, but also their scoring, validation and collection of data for the purpose of the committee in preparing the final forms of these unit tests. The tests, as they will be used in the experimental form, may be given as quizzes on the various unit subjects that they cover, and eventually are to be used for purposes of measuring achievement, and more especially for use in granting credit in various drawing courses in Colleges of Engineering.

The committee decided upon objective tests of multiple choice type, and agreed that we would hold strictly to this form and not include performance type tests. The fifteen unit experimental tests decided upon were to cover the following subjects:

1. Use of Instruments and Applied Geometry
2. Three-View Drawing
3. Reading Views (Missing lines)
4. Sections and Conventions
5. Auxiliary Views
6. Elementary Dimensioning

7. Screw Threads and Threaded Fastenings
8. Advanced Dimensioning
9. Working Drawings
10. Isometric Drawing
11. Oblique Drawing
12. Perspective Drawing
13. Charts, Graphs, and Diagrams
14. Intersections
15. Developments

Each member of the committee was assigned three of these units. In the two months that have intervened, we have prepared, tested, and checked experimentally some of these tests. Better than 25 per cent of our work has been completed and forwarded to Dr. Vaughn for editing and printing.

In our meeting held here at Minneapolis, Wednesday, June 18, we have formulated a schedule for the completion of experimental tests. Announcement will be made as soon as the schedule is determined by the Project Office when these tests will be available.

The committee wishes to recognize test material furnished by the following schools: Princeton University, Rutgers University, and Illinois Institute of Technology as well as that furnished from the committee members own schools. The chairman of this committee wishes also to acknowledge the help that has been given by various members of his own staff at the Ohio State University. We would appreciate particularly additional material on the subjects indicated of the objective type test so that we may use this as an aid in improving the tests in their final form.

We trust that these tests will be used in such quantity that we may have an accurate check on them, and also hope you will send us constructive criticism for their improvement. We realize that they will not be perfect and that several of them will need much revision. In offering suggestions for improvement, please be specific and furnish us with substitute material rather than just suggestions. The committee will then go over this material and select from it whatever may be necessary for the improvement and formulation of the final drafts.

We wish to particularly acknowledge the help that has been given to the committee by Dr. Kenneth W. Vaughn, Director of the Project Office, who has given considerable time in advising us on procedures and made it possible for us to get under way as rapidly as we have, as well as furnishing us the means of production and distribution of our work.

Respectfully submitted

W. M. Christman, Jr.
Maurice Graney
R. P. Hoelscher
John M. Russ
Ralph S. Paffenbarger, Chm.

REPORT OF VISUAL AIDS

The Visual Aids Committee held two meetings at Minneapolis last June. We discussed the scope of our assignment and the various types of Visual Aids now being used. The committee decided that our efforts for the present should be limited to surveying the slide, film and film strips now in use relating only to the teaching of Engineering Drawing and Descriptive Geometry.

Sectional chairmen will solicit assistance from division members in collecting this data by letter and interview, where possible, that we may know what is being used, its effectiveness in presenting subject matter and its effect on inspirational teaching.

Visual Aids Committee

Section A	J. S. Rising	Syracuse University
Section B	Justus Rising	Purdue University
Section C	H. L. Minkler	Illinois Inst. of Technology
Section D	L. G. Palmer	University of Minnesota
Section E	J. G. McGuire	A & M College of Texas
Section F	F. M. Warner	University of Washington
Industrial Division	C. L. Tutt, Jr.	General Motors Institute

H. B. Howe
General Chairman
Rens. Poly. Inst.

BIBLIOGRAPHY

MAGAZINE ARTICLES

Author	Title	Publisher	Vol.	Page	Mo.	Year
Ahearn J.	Precision method of checking compound angles	Mach.	53	178-81	Jan.	'47
Austin Co.	Something new in lighting and air conditioning; drafting room.	Civil Engineering.	17	264	May	'47
Barmasel, S. H.	Reproducing drawings on metal Kodak transfax process	Iron Age	158	62-4	Nov. 21,	'46
Birdsall, G. W.	Tool design streamlines drawing practice	Am. Mach.	91	78-9	Mar. 27,	'47
Burnetti, C. E. and Franklin, P. J.	Printed circuits.	Elec. World.	127	142	May 24,	'47
Boehmer, P. E.	Case for axonometric drawing.	Steel.	120	80-1	Mar. 24,	'47
Clark, D. E.	Photographic reproduction as an engineering tool	Iron Age	159	60-3	Feb. 6,	'47
Cellier, F. S.	Blueprinting the classroom film	Motion Picture Eng. J.	48	243-252	Mar.	'47
Engineer	Squared drawing paper	Engineer	183	171	Feb. 14,	'47
Factory Management	Why three dimensional layout.	Factory Management	104	93	Dec.	'46
Griggs, H. C.	Drawing office specification surface finish	Inst. Mech. Eng. and Proc. Engineering	153	339-40	War (#10) issue	'45
			159	237	Mar. 23,	'45
Hayes, P. J. Jr.	Decimalism; aviation industry adopts streamlined dimensioning.	Air Transport.	5	48-9	May	'47
Home Planers, Inc.	Five Dollar plans; new firm opens mass market for architects with model houses	Arch. Forum.	86	15-16	May	'47
Iron Age	Index of Industrial training films has 159 titles on metals	Iron Age	158	86	Nov. 28,	'46
Kunz, W. J.	Abbreviations standardized for 2,000 terms for use on drawings.	Ind. Stand.	18	84-7	Apr.	'47
Kothe, O. W.	Pattern for a cone to cone intersection.	Sheet Metal Worker	38	86	Apr.	'47
	Pattern for diagonal grainchute	Sheet Metal Worker	37	42	Nov.	'46
Lewis, W. A.	What the electrical engineering dept. needs from the drawing dept.	J. Eng. Educ.	37	653-9	Apr.	'47
Larri, G. A.	Graphical method of determining size of round blanks.	Mach.	53	147-8	Apr.	'47

MAGAZINE ARTICLES

Author	Title	Publisher	Vol.	Page	Mo.	Year
Mallick, R. W. and Porter, H. S.	Three dimensional models for planning plant layout; standards for templets are being developed . . .	Ind. Stand.	18	48-50	Mar.	'47
Norling, J. A.	Light control by polarization and the application of polarizers to the stereoscopic process	Motion Picture Eng. J..	48	129-44	Feb.	'47
Presutti, A.	New magic in old lines, pictorial Engineering drafting	J. Eng. Educ.	37	487-97	Mar.	'47
Potts, P. O. and Johnson, J. H.	Graphical solution to problem of connecting two lines by a third line which makes specified angles with it.	Mach. Design.	19	114-16	May	'47
Putman, R. C.	New lighting developments and their application to drafting rooms.	J. Eng. Educ.	37	389-401	Jan.	'47
Product Eng.	Examples of various welding designs and techniques; drawings .	Product Eng.	18	130-1	June	'47
Rose, K. M.	Materials and techniques for printed electrical circuits.	Materials and Methods .	25	73-6	Mar.	'47
Sanders, R. G.	How the camera transect is used in survey work.	Pub. Works.	77	23-4	Dec.	'46
S.A.E. Journal	Eighty per cent of aero industry favors decimal use	S.A.E.J.	55	82	Mar.	'47
Sheet Metal Worker .	Unusual in sheet metal as seen by a reporters camera; illustrations with text.	Sheet Metal Worker. . .	38	92-3	Jan.	'47
Spotts, M. F.	Dimensions and tolerances	Product Eng.	78	160-4 88-91 130	Feb.-May Feb.	'47 '47
Swain, P.	Math tips; useful facts from geometry	Power	92	204 277	Feb.-May	'47
Walters, W. E.	Simplified three dimensional drawing.	Mach. Design.	19	94-9	Jan.	'47
Wedge, A. C.	Drawing change system	Mach. Design.	19	101-4	Mar.	'47
Woodley, S. P.	Lofting and template reproduction . Discussion.	Roy Aeronautical Soc. J	51	306-24	Mar.	'47

REPORT OF THE BIBLIOGRAPHY COMMITTEE

Professor H. H. Fenwick, Chairman
University of Louisville

Author	Title	Ed.	Publisher	Year	Pages (Plates)	Prices
Aakhus, T. T. and Marmb, E. J.	Engineering Lettering and Dimensioning . . .	I	W. C. Brown Co. Dubuque, Iowa	'47	22	\$.75
Adams, D. P. and Douglas, R. D.	Elements of Nomography	I	McGraw-Hill	'47	229	3.50
Atkins, E. A. and Atkins, W. A.	Practical Sheet and Plate Metal Work	Rev.	Pitman Pub. McGraw-Hill	'47	606	3.75
Carini, L. F. B.	Drafting for Electronics		International Text Book	'46	462	3.50
Carter and Thompson.	Engineering Drawing and Problem Book		McGraw-Hill	'46	160	2.50
Coover, S. L.	Workbook in Mechanical Drawing	I	McGraw-Hill			
French, T. E. and Vierck, C. J.	Engineering Drawing.	VII	McGraw-Hill	'47		3.75
Levens, L. S. and Edstrom, A. E.	Problems in Engineering Drawing (Series 1) .	Rev.	McGraw-Hill	'47		2.50
Ogg, O.	Alphabet Source Book		Dover Pub. 1780 Broadway, N.Y.	'47	199	3.95
Spencer, H. C. and Grant, H. E.	The Blue Print Language.	I	Macmillan Co.	'47		5.00
Turner, W. W.	Simplified Perspective	I	Ronald Press	'47		

Texts by
William Wirt Turner

*Professor and Head of the Department of
Engineering Drawing, University of Notre Dame*

Just Out

SIMPLIFIED PERSPECTIVE

THIS sound textbook on the theory and practice of perspective drawing is prepared to meet the working needs of architectural and engineering classes, and of production drawings such as the exploded views finding increasing use in manufacturing. The subject is developed in clear cut, graduated steps to build up a mastery of principles and to present a clear understanding of the reason for each step followed in the practical preparation of drawings. Construction procedures are given on each drawing. Problems are solved in detail. In many cases methods which supplement one another have been combined to strengthen the student's grasp of the subject, save time, and give an infallible check on the correctness of results.

Contents: Perspective Elements. Oblique Lines and Planes. Parallel Perspective. Perspective Plan Method. Circles and Arcs. Reflections. Shades and Shadows in Perspective. Perspective Auxiliaries.

236 pages, \$5.00

Write for Examination Copy

FREEHAND SKETCHING FOR ENGINEERS

Develops the sketching ability of students and engineers, teaches theory underlying engineering drawing, and trains in the reading of drawings.

97 sheets, packaged in envelope. Teacher's Manual available. \$2.50

BASIC PROBLEMS IN ENGINEERING DRAWING

Revised Edition. Based on third angle projection. Instruction is closely related to drafting room practice and conforms to recommendations of the

American Standards Association. For use with any standard text. 112 sheets, packaged in envelope. Teacher's Manual available. \$2.50

BASIC PROBLEMS IN DESCRIPTIVE GEOMETRY

Based on third angle projection. Prepared for use with any standard text which employs the

direct or auxiliary plane method. 75 sheets, packaged in envelope. Teacher's Manual available. \$2.00

THE RONALD PRESS COMPANY
15 East 26th Street, New York 10

ENGINEERING EDUCATION IN THE FRESHMAN DRAWING ROOM

by

Professor Paul Hessemer
John Hopkins University

In the great majority of engineering colleges throughout the United States it seems to be customary to offer Mechanical (Engineering) Drawing before Descriptive Geometry. The arrangement of these two basic drawing courses in this or the opposite order is probably considered as of no great importance. However, the advantage which a reversal of sequence will offer deserves discussion.

On the occasion of a meeting of the A.S.E.E. I took advantage of the opportunity to ask several of the assembled professors which succession of the two courses is offered in the programs of their institutions. With expected uniformity they all stated that Engineering Drawing comes before Descriptive Geometry, but equally unanimous, though unsolicited, was the admission that it should be otherwise.

In the interest of engineering education I wish to propose that Descriptive Geometry be taught before Engineering Drawing because it contains the theory on which all mechanical drawing is based.

I trust that every teacher of these subjects has experienced difficulty on the part of the students to understand the principles of projection drawing and of auxiliary and sectional views. Had these students been introduced to the method of orthographic projection, edge view and normal views of planes and their intersection with solids, by means of a preceding course of Descriptive Geometry, this difficulty would have been all but eliminated. Under the present

procedure the necessary explanation of these constructions, given in a more or less makeshift fashion during the drawing course, are repeated during the following semester in a more thorough and theoretical manner under the heading of Descriptive Geometry. Valuable time could be saved for the study of Mechanical Drawing and spent there to the considerable advantage of a better understanding of conventional presentations, dimensioning and other baffling features which we like to call the "grammar of the graphic language." One semester is short enough for the attempt to develop more than a mere semblance of aptitude for drawing in the budding engineers.

Furthermore, if Descriptive Geometry is taught first, it may well be used to serve, during the initial class periods, as a very necessary refresher course in the fundamentals of geometric constructions. I find the average student, coming from high school, shockingly innocent of the rudiments of plain and solid geometry.

Beginning the freshman year with Descriptive Geometry offers also the opportunity to acquire skill in the use of the drawing instruments and helps to prepare the student for the following drawing course where the technique of his pencil work is of prime importance.

I have introduced this sequence of the two courses at The John Hopkins University, and one year's experience has convinced my colleagues and myself of the benefit the students derive from the change.

(Continued from page 24)

31. WHAT NOTATION DO YOU APPEND TO THE NEW PROJECTION?

The new position of each point revolved should have a subscript 1 added to each projection. If then turned to a second new position, a subscript 2 should be appended, etc.

32. PLEASE SUBMIT AN INKED DRAWING ILLUSTRATING YOUR USE OF NOTATION, AND ESPECIALLY THE CHARACTER OF YOUR LINE SYMBOLS.

There were comparatively few responses from authors to the above request. The two sketches herewith presented are a composite of current usage as gleaned from many texts, so far as line symbols are concerned, with the exception of projection lines, which are recommended strongly to be thin, full lines instead of the deadly time consumer, the finely dotted lines used in many texts. Your committee is conscious of the fact that very few drawings are inked today in descriptive geometry courses, yet these sketches were inked because better reproduction could be obtained and because all texts are so printed. In current text illustrations the massive, super-wide line is definitely out, presumably because if used in engineering drawing it would lead to graphic inaccuracy.

Henry C. T. Eggers
William E. Street

Francis M. Porter (Chairman)

The committee gives you this progress report with a considerable feeling of apprehension. From our own experiences in finding a common ground of agreement in a number of places, when only the ideas and long-time prejudices of five men were involved, it is obvious that there must be manifested on the part of the great multitude of authors and teachers of descriptive geometry a like spirit of generous yielding in order that our major objectives may be realized.

Reference has been made to the recently adopted standards for engineering drawing. It required many years, and the zealous effort of many minds, to succeed in establishing that very valuable code. Although its worth is immediately comprehended, it is recognized that it cannot be put into universal operation so quickly. It is observed, however, that each new text appearing conforms in almost every respect to its findings, which means that in only a comparatively few years its influence will be nation-wide.

A similar guide for the unifying of notation and nomenclature in descriptive geometry can be established in time by the willingness, on the part of those of us who in the past have held strong personal preferences in regard to these matters, to agree to support a reasonable set of standards at whatever cost. It may be confidently predicted that whatever sacrifices are made today, the accomplished results will be thankfully appreciated by our professional posterity.

J. Howard Porsch
Frank W. Warner

Hall and Kiley—

PATTERN DESIGN

A distinct advantage of this book is that it approaches the subject from the viewpoint of the engineer. Also, the number of special problems afford every student an opportunity to learn the principles involved in efficient design work. Since faulty design from a production standpoint involves considerable monetary loss and time delay, the efficient methods outlined in this volume will prove very helpful.

In order to clarify the subject matter, there are 200 excellently rendered line and half-tone illustrations in this textbook as well as a progressive series of 27 special problems. Prepared to develop the student's ability to visualize and design, the book can be incorporated in various drafting courses and helps to reduce shop work requirements. Because of the close relation between Pattern Design and Molding Practice, a description of Green-Sand Molding is presented in an early chapter to acquaint the students in the way in which patterns are used.

Contents

Pattern Details; Molding Details; Materials Used in Pattern Construction; Construction Work and Joints; Design for Low Cost Production; Pattern Department Management; Special Designs; Explanation of Work Required in Planning Pattern Equipment; Problems in Pattern Design; Glossary; Index.

193 pages, 5¼ x 8¼

227 illustrations

\$2.50

Send for an Examination Copy

International Textbook Company
Scranton 9, Pennsylvania

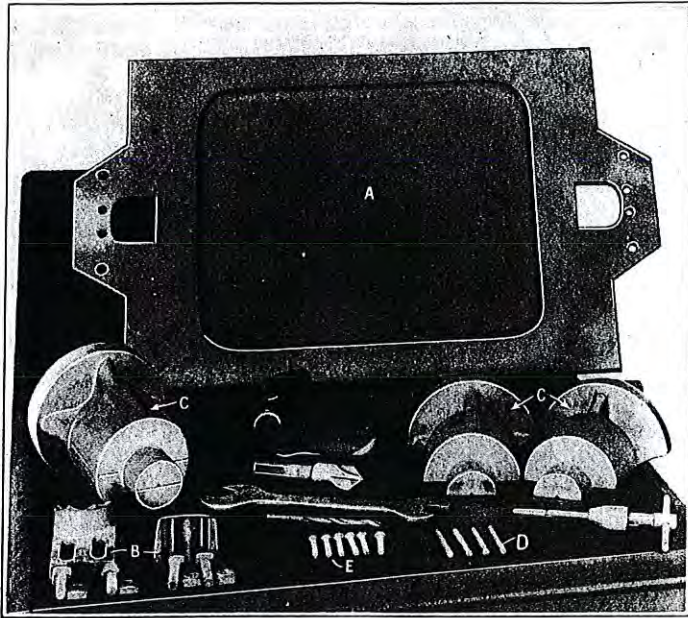

Metal plate, pattern, and accessories used in metal pattern work.



Pattern in position showing mold parted down.

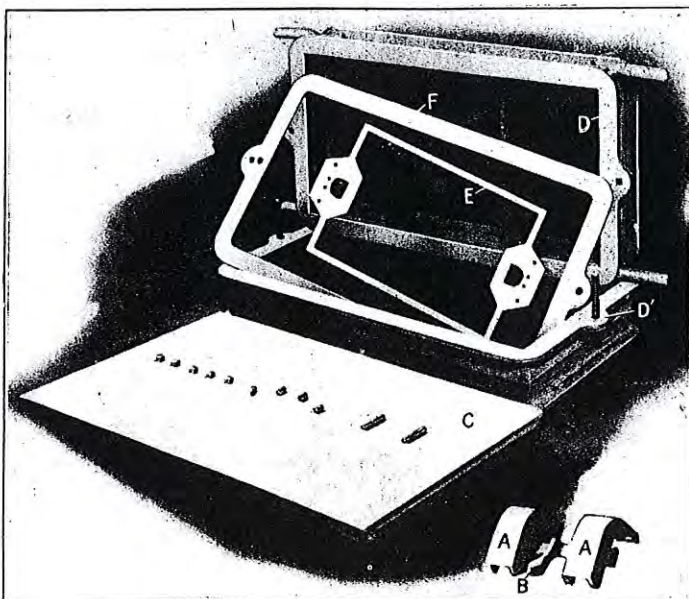

Metal patterns connected with gate, spacer frame, outline pattern for plate, and flask parts.