

VOL. 9, NO. 2

MAY, 1945

SERIES NO. 26

JOURNAL OF ENGINEERING DRAWING

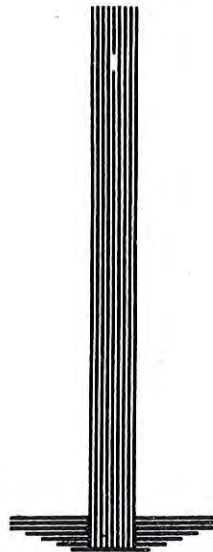

PUBLISHED BY
THE DIVISION OF ENGI-
NEERING DRAWING AND
DESCRIPTIVE GEOMETRY
S P E E

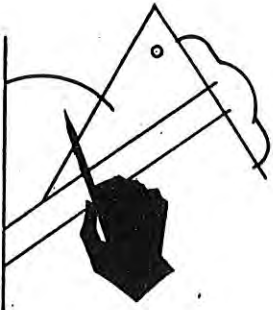

McGraw-Hill Announces

PROBLEMS IN ENGINEERING DRAWING

— SERIES I —

A. S. LEVENS

Associate Professor of Mechanical Engineering
University of California

and

A. E. EDSTROM

Lecturer in Mechanical Engineering
University of California

In press — ready in April

This distinctive set of engineering drawing problems, keyed to Thomas E. French's *Engineering Drawing*, Sixth Edition, consists of 52 drawing plates printed on vellum, together with about 25 pages of explanatory material, such as assignment sheets and instructions for the completion of each plate.

The primary purpose of the book is to provide, in a minimum number of plates, sufficient practice to enable the student to master the techniques of drawing in accordance with practice established by the American Standards Association.

Noteworthy Features

- The sequence of sheets which follows those of lettering includes (1) problems relating to useful geometric constructions, (2) problems that afford an opportunity to develop the student's ability to visualize and to think in three dimensions, and (3) translation exercises—from pictorials to orthographic drawings, and from the latter to pictorial drawings—in order to build confidence in an understanding of the fundamentals of projection.
- Sketching is stressed, since industry continues to make considerable use of isometric and oblique drawings as an aid in interpreting orthographic drawings.
- Studies in auxiliary views, sections, conventional practices, and dimensioning follow the work in isometrics and obliques. Problem sheets on conventional practices employ the most recent recommendations of the American Standards Association. The sheets on dimensioning include typical exercises and, in addition, problems relating to the dimensioning of pictorial drawings.
- This set of drawing problems, having been thoroughly tested in the classroom, successfully meets the needs of the student in engineering drawing. The sequence of problems in each classification (i.e., orthographic projection, isometric drawing, oblique drawing, etc.) provides a range from the elementary to the more difficult and was found to be effective in the training of hundreds of drafting and design personnel for war industries. Furthermore, this arrangement of problems enables the instructor to make a selection consistent with the training and industrial experience of his students.

Send for a copy on approval

McGRAW-HILL BOOK COMPANY, Inc.

330 West 42nd Street

New York 18, N. Y.

JOURNAL OF ENGINEERING DRAWING
PUBLISHED IN THE INTEREST OF TEACHERS OF ENGINEERING DRAWING
AND RELATED SUBJECTS

VOL. 9, NO. 2

MAY, 1945

SERIES NO. 26

CONTENTS

FRONTISPICE: Illustrated by Professor E. H. Brock, Agricultural and Mechanical College of Texas, Verse by Coleridge. Page 3

ENGINEERING DRAWING AFTER THE WAR: By Professor Jasper Gerardi, University of Detroit Page 4

JOB ANALYSIS FOR DIMENSIONING DRAWINGS: By Professor J. George H. Thompson, Agricultural and Mechanical College of Texas Page 7

GUIDE LINES: Memorial to Professor Thomas Ewing French, Let's Coin a Word, and A Graphical Problem to Investigate Mathematically Page 11

DRAFTSMEN IN THE MAKING: By Professor Sam M. Ford, Senior High School - Conroe, Texas Page 12

TECHNICAL SKETCHING: By H. H. Katz, Engineer, Republic Aircraft Corporation. Page 13

BIBLIOGRAPHY COMMITTEE REPORT: By Professor H. H. Fenwick, Chairman, University of Louisville Page 17

OBJECTIVELY SCORED DRAWING TEST PROBLEMS: By Dr. Maurice R. Graney, Purdue University. Page 19

PROJECTIONS: Current Events and Drawing Summer School. Page 26

ORTHOGRAPHIC PROJECTION AND THE CLOSE FITTING "GLASS BOX": By Professor J. G. McGuire and B. M. Gallaway, Agricultural and Mechanical College of Texas. Page 29

Annual Subscription Price, \$1.00

PUBLISHED IN FEBRUARY, MAY, AND NOVEMBER BY
THE DIVISION OF ENGINEERING DRAWING AND DESCRIPTIVE GEOMETRY OF THE
SOCIETY FOR THE PROMOTION OF ENGINEERING EDUCATION

PUBLICATION COMMITTEE

W. E. Street-Editor
Agricultural and Mechanical
College of Texas
College Station, Texas

J. N. Arnold-Advertising
Purdue University
Lafayette, Ind.

J. N. Wood-Circulation & Treas.
Kansas State College
Manhattan, Kansas

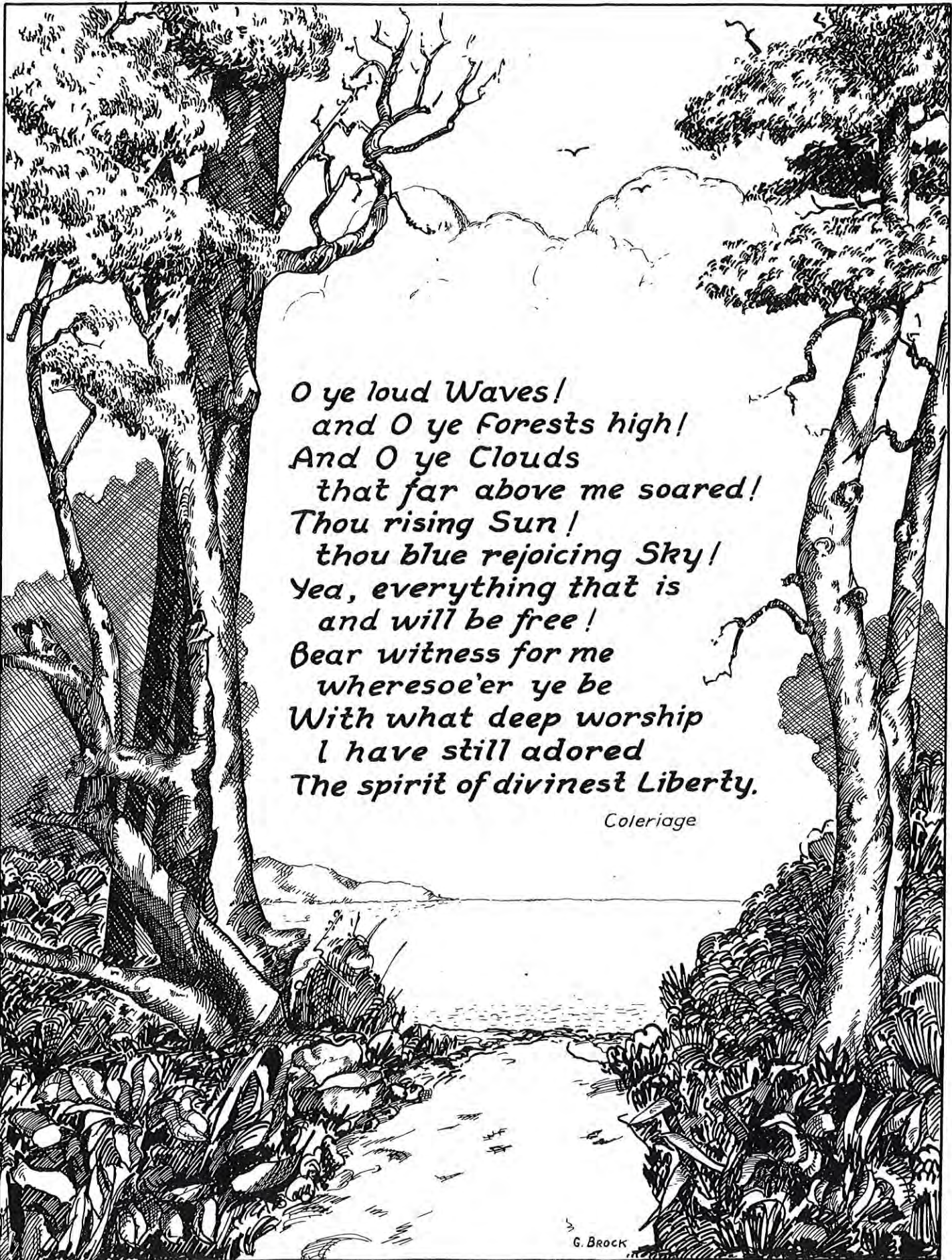

*O ye loud Waves!
and O ye Forests high!
And O ye Clouds
that far above me soared!
Thou rising Sun!
thou blue rejoicing Sky!
Yea, everything that is
and will be free!
Bear witness for me
wheresoe'er ye be
With what deep worship
I have still adored
The spirit of divinest Liberty.*

Coleridge

ENGINEERING DRAWING AFTER THE WAR

by

JASPER GERARDI
 Director of Engineering Drawing
 University of Detroit

The annual convention of the S.P.E.E. has been cancelled this year, and because of this the members of the Drawing Division can probably best express their opinions and exchange ideas through the Drawing Journal. This article is written to promote discussion, thereby stimulating the process of thinking on problems which face teachers of engineering drawing after the war

All of us anxiously await V-Day, not only because this heralds the dawn of a new economic era (which we hope will be better for humanity) but also because it will be the signal for the engineers to again direct the forces of nature to work for mankind rather than against it.

Our enemies have felt the effects of American ingenuity and production methods in this war. In a few short years America has created a war machine second to none, and in addition has extended greatly needed help to our Allies and liberated countries. Two reasons will probably summarize why we have been successful. First, full cooperation between groups of people in our country. Second, thorough training in all the professions, particularly the engineering professions.

Good engineering training calls for a thorough understanding of the engineers' language, namely, engineering drawing. Although it is a recognized fact that an engineer is not expected to be a good draftsman, he must nevertheless be able to direct draftsmen or junior engineers who often prepare drawings. As an engineer, he is responsible for the information which goes on a drawing before it is released to production. Usually the necessary information on a drawing is there, but it takes a Philadelphia lawyer with a magnifying glass and a great deal of that virtue called "patience" to ferret out the desired information.

Many engineers are complacent about drawings and argue that our system of making drawings is probably the most efficient in the world. "Haven't millions of drawings been made during this war?" "In addition, doesn't every community in this country have drawings for post war development?" And in a weaker voice, "Isn't production at a peak?" The answer to the first two questions is "yes", but we may answer the last question by asking the engineer "Why didn't production get up to its peak in a shorter length of time?" Of course, it is human nature to blame everything and everyone else, but it is very interesting to sit in a conference of engineers and production men, and in many cases find that time

was lost on a job because of a poorly executed drawing which had been misunderstood.

Our system of making engineering drawings is efficient, although much has to be done to preserve the three "C's" of drawing; namely, Clarity, Completeness, and Conciseness. Although war is supposed to accelerate scientific research and produce new material and methods which will improve civilian production, what changes may we expect in the teaching of Engineering Drawing courses after the war?

The following presents the detrimental effect of war on the teaching of drawing, and suggestions which will preserve and improve what little efficiency is left. Criticism of the following items, both pro and con, should make interesting reading and cause some serious thinking:

(1) Economic Adjustment for Drawing Teachers

In too many schools instruction has suffered not only because of military service, but also because the Universities have not been able to compete with wages paid in the industries. Enrollments are bound to increase after the war, and many teachers will have to be recruited from industry. Of necessity, therefore, teachers' salaries will have to be made more attractive if they are to interest men who have the proper qualifications to teach.

(2) Accelerated Courses

Success in any profession depends on thorough training, particularly in the fundamentals. Thorough training requires time, but war requires training in a short period of time. (Notice that the adjective "thorough" does not apply to wartime training). Much favorable publicity has been given to accelerated courses, so much in fact, that some people believe that all students waste ninety percent of the time spent in school.

Drawing courses as well as others have been streamlined to a point where because of a lack of time students have been taught how to do certain things without knowing why. An article in a recent publication gave publicity to a training program at one of our largest engineering schools which had streamlined its mechanical drawing course so much that in this program students are taught with emphasis on circuit diagrams.

If a course can be streamlined to put emphasis on only one phase of the work and it can still be called mechanical drawing, then "something is rotten in the State of Denmark!" In

spite of government and industrial streamlined training, the need for engineering draftsmen is still critical, and industry has been willing to absorb anyone who has had some training. The streamlining of drawing courses gives the false impression that drawing can be taught in less time. Drawing has gone through so many surgical operations that it was streamlined to a dangerous low long before the war. The war has caused it to be streamlined further, and unless it is "beefed up" to stand the shock of industrial criticism, the title "Mechanical Drawing" might just as well be discarded and a place of honor given to courses in blueprint reading.

(3) Text Books

The shortage of paper has caused some publishers to replace the pages of their books with inferior grades of paper. This could probably have been avoided if text books had been streamlined. The modern drawing text books use approximately one hundred and fifty pages to explain lettering, use of instruments, and geometric construction. This could well be cut down to three short chapters. This is followed by lengthy explanations of orthographic projection of simple objects, but scanty explanations and illustrations of auxiliary views and sectional views. Although this requires three or four chapters of explanation, less could be said of the easier problems of projection and more detailed explanation should be given regarding auxiliary views and sectional views. The chapters usually devoted to shop processes and dimensioning should be expanded and well coordinated, particularly with reference to limits and tolerances. The remaining chapters dealing with drawing in Civil Engineering, Chemical Engineering, etc., etc., which generally cover the last one hundred and fifty pages - from which very few people teach - could well be omitted because specialized training in drawing can be taught in the departments concerned. Here then is the proper place for streamlining, and the sooner the better for everyone concerned. A text book of about two hundred and fifty pages of well coordinated material will probably contain more than a student can possibly learn in an average college course.

The authors of text books will probably have something to say about this, but in their criticisms they should state just how much a teacher of engineering drawing is expected to know and also, assuming that the teacher is thoroughly familiar with everything in the text book, how much a student can learn in approximately four hundred class hours of instruction.

(4) National Examinations Committee and E.C.P.D.

Professor J. L. Hill, Jr. of the University of Rochester reported on the work of the Committee to Formulate National Efficiency Tests in Engineering Drawing. This partial report was presented at the Cincinnati meeting last year, and gave evidence of a very

thorough study. Although this study is not yet completed, it is hoped that the Committee can develop a plan whereby the results of these national examinations will be helpful to teachers in preparing the syllabi for their drawing courses. All teachers of drawing should be interested in the final report and give this Committee full cooperation.

The appointment of a committee on examinations is a step in the right direction, but why hasn't a committee been appointed to discuss and report on the qualifications of a good teacher, the contents of a well balanced course, and the amount of time required to adequately cover each phase of a drawing course? Committees appointed to do this work could work jointly with the Committee of Examinations and do a great deal to eliminate the deficiencies in drawing courses as reported by Professor Hoelscher in his report "National Survey of Engineering Drawing" (Cf.: June 1943 issue S.P.E.E. JOURNAL).

If these committees could publicize their recommendations before the enrollments at the engineering schools begin to swell, then changes in the present syllabi, teaching staffs, etc., could be contemplated and improvement could take place immediately after the war.

Of course, the E.C.P.D. would probably have to support these committees, but this should not be difficult, particularly if E.C.P.D. would request the services of a qualified member of the Drawing Division to help them in their investigations of the departments of Engineering Drawing. The E.C.P.D. should be willing to request an additional member to their council because this would relieve them of work which does not particularly interest them.

(5) International Problems

It is difficult to think of international problems existing in the field of drawing, but this war has proven that a real problem exists. If we can believe what we read in various periodicals, it is hoped that a great deal more American machinery and other equipment is going to be used in foreign countries than ever before.

During the early part of this war - and even now - a great number of drawings from Europe were sent to this country. Countless man hours have been lost in trying to decipher these drawings. As a matter of fact, in many cases some industries have had to redraw these foreign engineering drawings to save the time of their tool designing departments.

Of course, the biggest trouble is well-known to most of us - namely, that all European drawings are in first angle projection. If the exchange of drawings between the United States and foreign countries is going to increase, then a discussion is in order as to the advisability of devoting more time to first angle

(Continued on page 15)

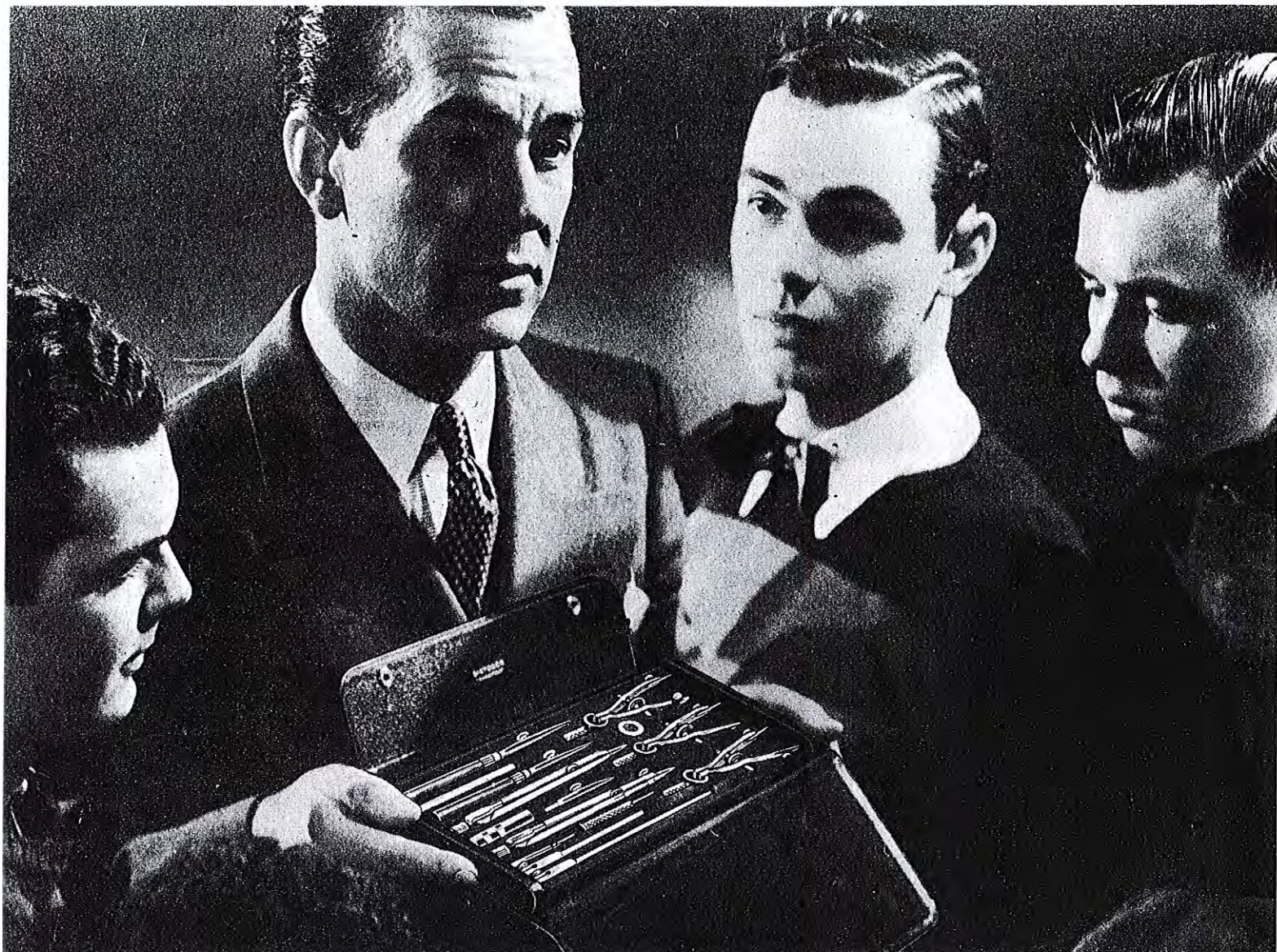

Whose eternal vigilance for what human liberty?

● The lads that crowd our classrooms today are this generation's investment in the future. Tomorrow they will be men, representatives of our dreams, hopes and aspirations for a better world. Yet the war has shown us that such a better world is no matter of easy, comfortable inheritance, but of struggle, vigilance, courage, discipline and ideals. Nor are *these* latter qualities a matter of divine heritage. These too must be fought for . . . and the eternal vigilance of the educator is one of the prices to be paid for the human liberty we all want. In *his* vigilance is the measure, the honor and the worth of his calling.

For no one knows how to easily instill high standards in a growing lad. No one knows surely how to give direction to a youngster's restless desires . . . how to fortify his will, how to fan into flame the spark that resides in the breast of all. Only as the educator is ever on the alert can he find and apply those influences that make so tremendous a difference in the lives of the boys he teaches.

For example, when a youngster first comes to drafting class: how shall the instruments he will use be selected? Shall they be carelessly chosen and cavalierly treated? Is it reasonable to expect that carelessness here will lead to carefulness in work? Yet in this class there is a golden opportunity to capture a boy's interest at its flood and so lead him on to discriminating standards, a concern for

craftsmanship, a sense of the disciplines so necessary in adult life. In his drawing instruments there is an opportunity to create pride of possession, forerunner of pride in craftsmanship, which can lead to the habit of doing *all* things well. Shall the keynote of this introduction be indifference? Shall his drawing instruments be anything but the best he can afford? It would seem that poorly made, carelessly selected drawing instruments cannot be an economy, but are the final and most intolerable extravagance of all.

EUGENE DIETZGEN CO.

Chicago • New York • San Francisco • New Orleans
Pittsburgh • Los Angeles • Philadelphia
Washington • Milwaukee
Dealers in All Principal Cities

DIETZGEN

EVERYTHING FOR
DRAFTING AND SURVEYING

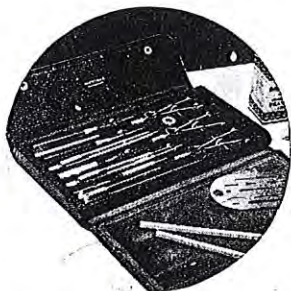

Army-Navy "E" Production Award
for Excellence in Manufacturing,
Drafting and Surveying Instru-
ments and Supplies for the Armed
Services of the United States.



JOB ANALYSIS FOR DIMENSIONING DRAWINGS

by

J. GEORGE H. THOMPSON

Associate Professor of Mechanical Engineering
Agricultural and Mechanical College of Texas

This article introduces a job analysis sheet, discusses how the use of this form will help instructors of engineering drawing, and gives a number of problems to be assigned in connection with the job analysis sheet.

The job analysis sheet is a form designed to assist the student in making an analysis of how a part is to be produced. On this sheet the student is asked to outline the sequence of operations to be followed in the manufacture of a part for which he is preparing a detail drawing. This form, being nothing more than a simplified operations sheet, is practical and useful in the hands of college freshmen. It will focus the attention of the student on some of the reasons behind the rules he learns in his drawing course. He will see, for example, that the draftsman must consider just how a part is to be laid out and made in the shop if he is to make the most appropriate decisions as to how to dimension his drawing.

Consider job # 8 in figure 2 except that the dimension $2.0000 \pm .0001$ be replaced by a dimension $2.000 \pm .001$. A finished solid block is supplied and it is desired to analyze the job of producing the two holes of, say, $3/4$ " and $1/2$ " dia. respectively into which the bushings are to be pressed. Of the possible methods of locating these two holes, four suggest themselves at once. To scribe and punch mark would probably be the most common albeit least accurate. To scribe and locate by use of centerscope would probably be the most modern procedure. The use of buttons is an old standard which well deserves its universal respect. The use of a drill jig would undoubtedly be worth considering if a number of identical parts were to be produced.

The method of producing the holes themselves is quite flexible and may be adapted to fit the particular circumstances of each case. The student should certainly be reminded to consider holes not only as to size but as to straightness and roundness also. The drilled hole, at best, is a pretty inaccurate job which is out of round, off size, and not straight. The drill may be considered, in general, as a rough method for removing material. To correct for straightness and roundness a generating operation such as boring should follow the drilling. The reamer is commonly used to follow the boring operation for the purpose of making the hole to size. Correct boring, however, gives holes such that

subsequent reaming is often unnecessary. Slightly tapered end mills of suitable accuracy are sometimes employed to finish a hole that has been rough drilled. No further finishing is necessary. Honing, lapping, and superfinishing are designed to improve surface finish and ordinarily remove so little material as not to change the dimensions of a part materially.

Let's see, in Figure 1, how four hypothetical students might analyze this job. Joe Blink has used a drill jig on the basis of the large number of similar parts which he desires to produce. Jim Jones has a different solution. He employs a process in keeping with the fact that he desires to make only one part. Notice how his "Prepare for Drilling" opens the way for remarks on the part of the instructor. Such things as lead drilling can most effectively be explained now that the student's interest has been whetted. In John Hall's solution, the teacher has a chance to explain the use of the centerscope. Here, also, is an opportunity to discuss the use of the toolmaker's knee, vernier height gage, etc. In Bill Smith's solution the use of micrometers to set buttons may be explained. Here, also, is an opportunity to bring in the use of gage blocks in connection with the setting of the buttons. This same problem also illustrates the use of the dial indicator.

This form of job analysis sheet is not intended to show all the information given on a commercial operations sheet. In that very point the job analysis sheet is valuable. It helps the student to visualize how a part is made and yet it does not confuse him.

Figure 2 shows a number of jobs for the students to try. Each job has points worthy of thoughtful study. Instructors are welcomed to reproduce the job analysis sheet and any portions they desire of figure 2. These problems all came from actual jobs. While certain details have been modified, all of the eight jobs came from practical cases. In job # 2 it is very important that the student call for the $1/16$ holes to be drilled before the $.316$ surfaces are cut. Since this is tool steel, the student will have to be careful of decarburization although this point will not be of interest to the average freshman. Job # 8 is very important because it will reveal the urgent need to consider carefully before calling for any more accuracy than is really needed on a job.

1. Part Name <u>CLAMP BLOCK</u>		JOB ANALYSIS SHEET	
2. Number Required <u>740</u>		STUDENT <u>JOE BLINK</u>	
3. Material <u>COLD ROLLED STEEL</u>		JOB # <u>8</u> DATE <u>4-11-</u>	
4. Raw Stock Bar <input checked="" type="checkbox"/> Sheet <input type="checkbox"/> Forging <input type="checkbox"/> Casting <input type="checkbox"/>			
5. Special Instructions _____			
6. Can you see how the production of the part can be improved by slight changes in shape, size or material?			
7.	Description of Operation	Machine or Bench	Remarks
	INSPECT FOR BURRS	BENCH	
	DRILL & REAM IN JIG	DRILL PRESS	
	BURR	BENCH	

1. Part Name <u>CLAMP BLOCK</u>		JOB ANALYSIS SHEET	
2. Number Required <u>ONE</u>		STUDENT <u>JIM JONES</u>	
3. Material <u>COLD ROLLED STEEL</u>		JOB # <u>8</u> DATE <u>4-11-</u>	
4. Raw Stock Bar <input checked="" type="checkbox"/> Sheet <input type="checkbox"/> Forging <input type="checkbox"/> Casting <input type="checkbox"/>			
5. Special Instructions _____			
6. Can you see how the production of the part can be improved by slight changes in shape, size or material?			
7.	Description of Operation	Machine or Bench	Remarks
	SCRIBE HOLE CENTER LINES	BENCH	
	PREPARE FOR DRILLING	BENCH	
	DRILL $\frac{3}{4}$ " HOLE	DRILL PRESS	DRILL UNDERSIZE
	REAM $\frac{3}{4}$ " HOLE	DRILL PRESS	REAM TO SIZE
	DRILL $\frac{1}{2}$ " HOLE	DRILL PRESS	DRILL UNDERSIZE
	REAM $\frac{1}{2}$ " HOLE	DRILL PRESS	REAM TO SIZE

1. Part Name <u>CLAMP BLOCK</u>		JOB ANALYSIS SHEET	
2. Number Required <u>ONE</u>		STUDENT <u>JOHN HALL</u>	
3. Material <u>COLD ROLLED STEEL</u>		JOB # <u>8</u> DATE <u>4-11-</u>	
4. Raw Stock Bar <input checked="" type="checkbox"/> Sheet <input type="checkbox"/> Forging <input type="checkbox"/> Casting <input type="checkbox"/>			
5. Special Instructions _____			
6. Can you see how the production of the part can be improved by slight changes in shape, size or material?			
7.	Description of Operation	Machine or Bench	Remarks
	SCRIBE HOLE CENTER LINES	BENCH	
	LOCATE $\frac{3}{4}$ " HOLE-CENTERSCOPE	DRILL PRESS	
	DRILL $\frac{3}{4}$ " HOLE	" "	DRILL UNDERSIZE
	REAM $\frac{3}{4}$ " HOLE	" "	REAM TO SIZE
	LOCATE $\frac{1}{2}$ " HOLE-CENTERSCOPE	" "	
	DRILL $\frac{1}{2}$ " HOLE	" "	DRILL UNDERSIZE
	REAM $\frac{1}{2}$ " HOLE	" "	REAM TO SIZE

1. Part Name <u>CLAMP BLOCK</u>		JOB ANALYSIS SHEET	
2. Number Required <u>ONE</u>		STUDENT <u>BILL SMITH</u>	
3. Material <u>COLD ROLLED STEEL</u>		JOB # <u>8</u> DATE <u>4-11-</u>	
4. Raw Stock Bar <input checked="" type="checkbox"/> Sheet <input type="checkbox"/> Forging <input type="checkbox"/> Casting <input type="checkbox"/>			
5. Special Instructions _____			
6. Can you see how the production of the part can be improved by slight changes in shape, size or material?			
7.	Description of Operation	Machine or Bench	Remarks
	TAP FOR BUTTONS	BENCH	
	ADJUST BUTTONS	BENCH	
	LOCATE $\frac{3}{4}$ " HOLE IN LATHE	LATHE	
	REMOVE BUTTON	"	
	DRILL $\frac{3}{4}$ " HOLE	"	DRILL UNDERSIZE
	BORE $\frac{3}{4}$ " HOLE	"	BORE TO SIZE
	LOCATE $\frac{1}{2}$ " HOLE IN LATHE	"	
	REMOVE BUTTON	"	
	DRILL $\frac{1}{2}$ " HOLE	"	DRILL UNDERSIZE
	BORE $\frac{1}{2}$ " HOLE	"	BORE TO SIZE

LETTERED BY S. M. CLELAND

Fig. 1

JOB ANALYSIS

GIVEN:

SKETCH

REQUIRED:

DETAIL DRAWING

JOB ANALYSIS SHEET

JOB 8

ONE REQ'D. PRESS
HARDENED STEEL
DRILL BUSHINGS

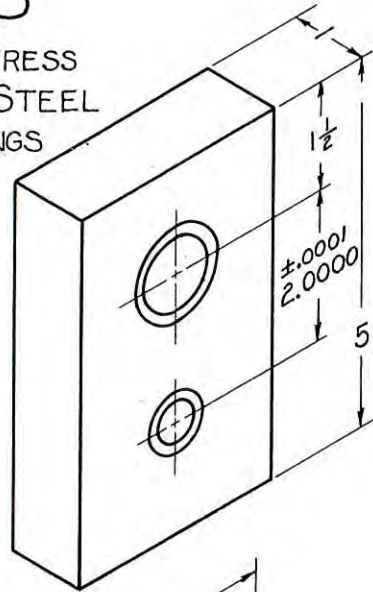

JOB 1

ONE REQ'D. C. R. S.

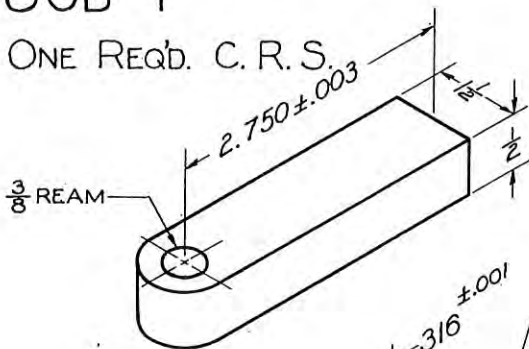

JOB 2

ONE REQ'D.
TOOL STEEL

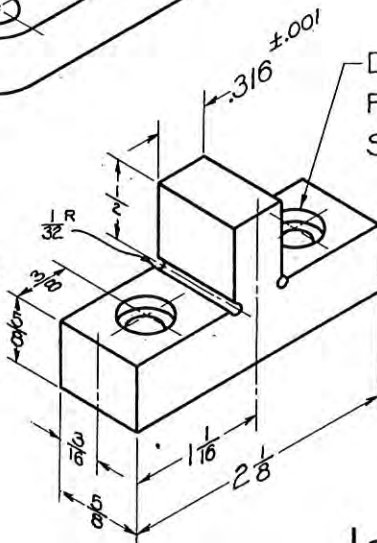

DRILL & C'BORE
FOR 1/4" SOCKET HD.
SET SCREW

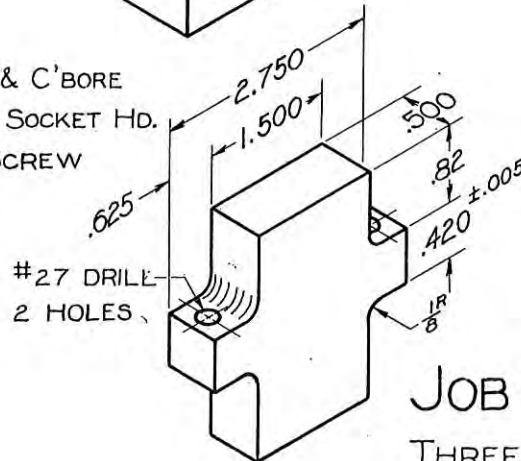

JOB 7

THREE REQ'D.
TOOL STEEL

JOB 3

ONE REQ'D.

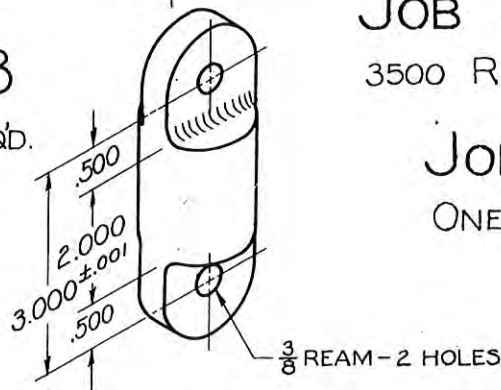

JOB 4

3500 REQ'D.

JOB 5

ONE REQ'D.

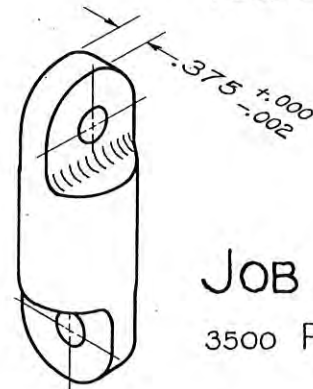

JOB 6

3500 REQ'D.

JOBS 3, 4, 5, 6 MADE FROM 1" DIA. C. R. S.

DRAWN BY:
S. M. CLELAND

New Third Edition
of
MACHINE DRAWING

The Leading Textbook in the Field of Machine Drawing

by

CARL LARS SVENSEN

Consulting Engineer, Lubbock, Texas, Author of "Drafting for Engineers", etc.

THIS new edition is ideal for present-day courses, especially where time is limited. Its use in connection with descriptive geometry will give a thorough understanding and more usable grasp of drawing because in this arrangement the theory is covered in the course or past course on descriptive geometry, so that the work on machine drawing can stress practical drafting. This book is excellent for review courses and "speed-up courses". It provides a thorough preparation for machine design due to such features as its illustrations, which represent modern industrial practice, and which have been increased in number by more than 80 in the new edition. Three new chapters, 50 more pages and 90 additional problems meet every need of present-day courses.

It is more than another book on mechanical drawing or engineering drawing. It has the qualities of applied reality so necessary for any engineering subject today. It is direct and its approach makes the student familiar with conditions which he will encounter in engineering and manufacturing practice.

CHAPTER HEADINGS

<i>Elementary Principles</i>	<i>Shafting and Couplings</i>
<i>Threaded Fastenings</i>	<i>Jigs</i>
<i>Welded and Riveted Construction</i>	<i>Fixtures and Details</i>
<i>Principles and Practice of Dimensioning</i>	<i>Gears and Cams</i>
<i>Machine Drawing</i>	<i>Piping Drawing</i>
<i>Machine Sketching</i>	<i>Problems and Studies</i>
<i>Machine Details</i>	<i>Supplementary Problems</i>
<i>Bearings</i>	<i>Appendix</i>
<i>Pulleys, Belts, etc.</i>	

Illustrations	6 x 9½	Cloth	280 Pages	\$2.50
----------------------	---------------	--------------	------------------	---------------

Please request an examination copy of this textbook

D. VAN NOSTRAND COMPANY, INC.

250 FOURTH AVENUE

NEW YORK 3, N. Y.

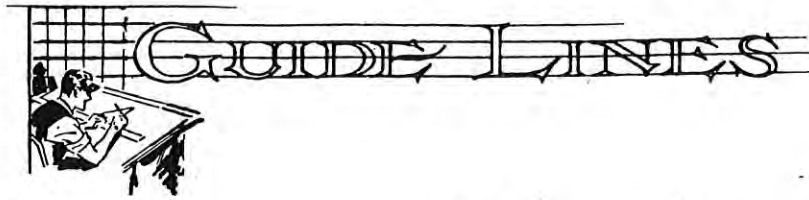

A MEMORIAL TO
PROFESSOR THOMAS EWING FRENCH

I wonder if the members of the Drawing Division of S.P.E.E. would like to provide a bronze tablet to be placed in Brown Hall at Ohio State University (with the approval of the University authorities) as a memorial to Professor Thomas Ewing French?

Contributions for such a memorial should not be limited to members of the Drawing Division but the privilege should be extended to all of his friends.

Carl L. Svensen

After Professor Svensen presented this idea to the editor it was taken up with Professor Ralph S. Paffenbarger, Chairman of the Engineering Drawing Department, of Ohio State University.

Professor Paffenbarger writes as follows: "I took the matter of the memorial up with the University authorities and they were pleased to know that such a project was being considered by the Drawing Division of S.P.E.E.

"Yesterday at our department conference, the unanimous approval was voted."

The Engineering Drawing Department of Ohio State is now in the process of setting aside Professor French's office as a Memorial Library. They are sponsoring the preparation of a bronze bust of Professor French, which was sculptured by Wooster B. Field and which will be cast and included as one of the projects in this Memorial Library.

The editor has talked with several people about this Memorial and everyone contacted was in favor of the project.

Members of the Drawing Division, here is an opportunity to share in a Memorial dedicated to that inspirational leader Thomas Ewing French. Please write to one of the following people indicating your wishes pertaining to the undertaking of this project. Professor Carl L. Svensen, 511 Ewell Nalle Bldg., Austin, Texas; or the editor of the Journal of Engineering Drawing.

LET'S COIN A WORD

For consideration of the Drawing Division of S.P.E.E. Dr. Clair V. Mann, Head of the Engineering Drawing Department, of the Missouri School of Mines offers the following suggestion and writes: "A number of times in meetings of the Division or executive committee conferences the question of selecting a name for the 'sum-total' of the great body of scientific, engineering, and architectural drawings that exists (or has been produced) has come up.

"LINEATURE. (Linature, Delinature, or Graphiture). Expressing the same meaning in connection with drawing

that literature has in connection with writing."

"LIN'-EA-TURE. (May be shortened to Lin-a-ture, or may be used interchangeably with 'De-lin-a-ture' or even 'Graph-i-ture.') Lineature is from the Latin Lin-e-a, meaning 'a line'. De-linature adds on the prefix 'de', also from Latin, meaning from, down, off or away. Consult 'Webster', the words 'delineation', 'line', and 'graphic'. The latter is from the Greek, and means 'written'. 'Delineation' refers to the indication, by lines (rather than by shades or color) the form of an object or figure or something that has shape. Representation by sketch, design, or diagram. Portrayal, picturization. Representation with accuracy or minuteness, as distinguished from picturization that is careless in details, or that subordinates them, as in tinting or generalized shading.

"LET'S COIN A WORD. What does the Division of Drawing say? Which of the four words are to be preferred - Graphiture - Delineature - Linature -- or Lineature? Which is easiest to pronounce - sounds best? Let's coin a word that is our own - that will connote 'the sum-total of graphic products non-ephemeral!'"

Clair V. Mann

A GRAPHICAL PROBLEM
TO INVESTIGATE MATHEMATICALLY

Professor George J. Hood of the University of Kansas writes: "While plotting some ellipses with a trammel, I became curious as to what would happen if the two lines taken as axes were not perpendicular. The drawing below shows the results. Possibly some reader of the Journal who keeps up his analytics may be interested in determining if the resultant figures actually are the ellipses they seem to be."

Send your solutions to the editor of the Journal of Engineering Drawing before August 15, 1945 and one or more will be carried in the November 1945 Journal.

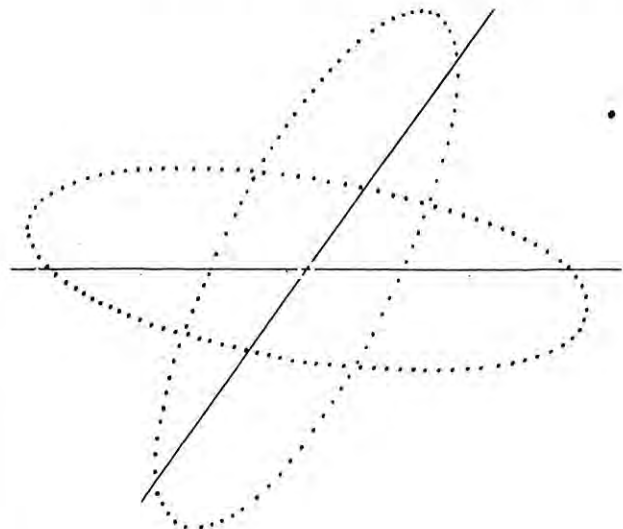

DRAFTSMEN IN THE MAKING

by

SAM M. FORD

Director of Industrial Education
Senior High School - Conroe, Texas

The high school lads who sit behind drafting room tables today and labor over drawing problems are the future draftsmen of America. These youngsters possess the fundamentals which can be turned into achievement and success if we as instructors sense the true responsibility which is ours and constantly seek to set fire to their imaginations; to foster such vision and inculcate those habits that help so much to translate ideas into immediate and directed action, so that they may experience early in life the never-to-be-forgotten thrill of achievement. Too often we have in our classes boys who are possessed with talents and the kind of courage that will carry them far in the field of drafting, yet we as teachers fail to take advantage of a golden opportunity to direct them toward such a vocation. To be sure, some are destined to become outstanding men of their profession, but none of us are so wise that we can look over a class of high school boys and pick the ones who will contribute the most in the field of engineering and designing of tomorrow.

We have only to read of the lives of great men who have contributed much toward civilization during the last two centuries to learn that genius is not so much born in a man-to-be as it is stirred up in him. Take the five hundred "Modern Pioneers" who a few years ago were honored the country over because of their outstanding contributions to progress through pioneering achievements on the American industrial frontiers. Could you or I have picked them out as boys and foretold their future? No, I am sure we could not.

And so it is with the boys in our drafting classes in this day and time. Ability, the spark of achievement, and the will to win....these are the possessions of every boy. What happens later is not the results of heritage, but the influences that are brought to bear on the boy.

Look back through the life history of any man of achievement and you will find this "something", a point within the formative years of his youth where the spark of desire was struck and fanned into a flame. His way of thinking was changed, each task of the day was no longer a pointless drudgery of the

moment, but a new and decisive step toward a definite aim and a goal in the future.

We, as instructors, have come to know more and more how delicate is the task of shaping young lives. We must get away from chance.... we are dealing with human beings....the men of tomorrow. When a youngster comes to our drafting class, we must help him to clip the wings of fancy, and to busy ourselves with the task of centering his ambitions on what is practical and what is achievable. It is our duty to give him new vistas of possibility, yet reveal to him the down-to-earth mechanics of achievement. If he is to be a successful draftsman, then he must certainly learn the value of accuracy, of precision, thoughtfulness in judgment and decision. The standards set in our drafting courses must be kept high and the incentive instilled into the students never to be satisfied with anything but their best.

This industrial age in which we are living is marked with many and rapid changes, great engineering achievements, adoption of mechanical equipment and devices un-heard of before, and the steady and rapid increase in industrial processes have necessitated a corresponding increase in technical knowledge and skill. Mechanical drawing has played an important role in this development and will continue to play an important part in industry. As machines and manufacturing methods become more complex and refined, the drawings from which they are evolved require greater precision, accuracy, and understanding in their making as well as their uses. Regardless of whether considered as a valuable subject in general education, or as an essential pre-engineering course, or as an occupational subject in the trade and vocational schools, the increasing importance of mechanical drawing as a secondary school subject demands some serious study and discussion of better teaching methods.

This should be a challenge to each of us to do his task the very best possible way and to plan the work well and keep it up to date in every respect so that our students going out from our classes may have a chance to compete and to win success with the best in the field.

TECHNICAL SKETCHING

by

H. H. KATZ, Engineer
 Republic Aircraft Corporation

Before expounding the virtues of technical sketches the writer wishes to say, for the benefit of many "non-sketch-minded" professional engineers, that the blueprint or mechanical drawing, produced with the mechanics of orthographic projection and descriptive geometry, is capable of presenting the shape description of objects to be manufactured far more accurately than a pictorial or "aesthetic" representation.

Technical sketching, the practice of freehand orthographic and pictorial engineering drawing, is intended to supplement the mechanical type of representation--thereby expanding the engineer's means of imaginative thought and graphic expression. Although sketching applications are becoming increasingly popular in industry, they do not attempt to minimize or in any manner substantially replace the conventional type of mechanical drawing.

It is also interesting to note here that technical sketching from the engineer's viewpoint should not be confused with the art of the production illustrator or the industrial artist. The production illustrator's art is highly specialized within itself and is essentially non-creative from an engineering standpoint. The engineer's technical sketches create the design and obviously precede the production illustration.

Perhaps the most common application of technical sketching lies in the execution of the "idea" sketch. The function of the mechanical drawing is to impart description, instructions, and specifications to the shop so that a three-dimensional object may be manufactured. Obviously, a three-dimensional mental picture must first be conceived by the designer. It is in this initial stage---searching, experimenting---that the designer records his thoughts by means of more or less rapid sketches. These sketches may be drawn in orthographic views or as rough pictorials, the choice of method depending on the nature and complexity of the subject. Often, three-dimensional studies are desired, but are not attempted due to the inability of the engineer to impart an adequate pictorial drawing. There are direct successful methods for drawing rapid freehand sketches, with an objective of function rather than beauty, yet drawn well enough to instill a sense of realism and confidence in the observer. Engineers possess, by virtue of training, inclination, and practice, methodical and constructive minds; and since it has been proved that anyone of average intelligence can learn to draw, it is most assuredly certain that engineers may acquire the ability rapidly.

Technical sketching fosters creativeness and individual ingenuity. Ideas, so essential to the engineer, when recorded upon first contact may prove of future value on the drawing board; otherwise, when trusted to memory may slip by and never be employed. Ideas recorded on the backs of old envelopes and other miscellaneous papers have been the source of many engineering discussions, projects, designs, and inventions. Every engineering student is familiar with the famous Leonardo da Vinci notebooks, wherein sketches described the greater part of many unique engineering ideas and projects, and with Thomas Edison's rough pictorial sketches that served as the embryos of inventions that changed the course of our modern living.

Mr. A. Kartvelli, chief engineer of the Republic Aircraft Corporation, created the basic idea of the now famous P-47 Thunderbolt pursuit airplane on the back of an old postal card while in discussion with a group of Army fliers and officials.

Tommy Jones was given the job of designing a machined fitting. It is customary in the design of aircraft, for a number of supervisory and allied group engineers to gather about the drawing board upon which a design is in process of development. Opinions and arguments are offered pro and con changes and innovations suggested, compromises made, etc. Tommy, anticipating such a conference, drew a small freehand pictorial sketch at the bottom left-hand corner of the layout, first, to guide his layout procedure and, second, to act as the source of the coming discussion. If any pencil markings were to be made, they would not be on his carefully projected layout lines, but on the technical sketch. His pictorial sketch makes discussion easier; the design is readily visualized and all discussion is referred to it. Since the sketch is not drawn to scale or with regard to great accuracy, such questions as "Will this angle clear the Oleo?" or "Have we sufficient rivet area to carry the load?" can be answered readily by scaling the precise layout lines.

The rather complete conception of the physical characteristics of the design in the technical sketch facilitates discussion and general analysis before the painstaking mechanical drawing is considerably developed or completed. The time element involved is more than compensated for - because a clear understanding of where lines are to go actually constitutes the greater part of drafting time; also, ironing out basic design considerations in the sketch lessens the irritating task of erasing and re-drawing on the production drawing. Since the sketch offers an easily visualized overall

picture of the design, the effect of a change of design pertaining to one section can be seen readily in relationship to the whole scheme.

The "reading" of blueprints or the interpretation of the flat views into a visualization of the actual objects requires constructive imagination. Ordinarily, the engineer encounters little difficulty in reading the general run of engineering drawings. However, it is often necessary to interpret large complicated prints or vendor (outside the company) prints, wherein an unfamiliar style and subject matter is depicted. In this case, it is convenient to analyze various sections and sketch them pictorially, then to coordinate the entire picture mentally with the help of the sketches. This system does not tax the mind to recall details throughout the entire print in an effort at coordination. The method is equally adaptable to the manufacturing end and to design.

To the engineering supervisor technical sketching is a "must have". His constant analysis and discussion of the draftsman's problems requires a definite, well-defined, and easily visualized suggestion, explanation, or criticism. Many supervisors, finding an explanation too difficult to put over orally or in orthographic views, have remarked, "If only I could draw a picture of this". Yes, the old adage is apparently true, one picture IS worth ten thousand words.

Along with uses in the field, the everyday applications of technical sketching in the drafting room are so numerous that this space only allows for a few examples. For purpose of experiment, the writer carefully observed the contents of a wastebasket in the engineering department of the Republic Aviation Corporation. Some of the sketches found there are described below:

An orthographic sketch of basic lines and dimensions from an existing blueprint for purposes of determining clearances for an asta-compass installation.

A pictorial sketch with cardinal dimensions for a fuselage belt-frame and adjacent structure, lent by the designer to a wing group layout man to study wing fuselage inter-sections.

A pictorial study of a series of wing ribs with alternate arrangements for attachment to skin and stringers--probably the result of a conversation between designer and production engineer.

A series of attempts to pictorially represent the intersection of a spherically shaped navigator's observation dome, with a cylindrical fuselage, so that the fairing might be visualized.

A large sheet with a multitude of seemingly incoherent lines, vectors shooting in all directions, carelessly written loads -- such sheets are typical of heated arguments that sometimes occur between design and stress engineers.

A number of simple view arrangements and sections of a large bomb bay structure -- a detailer's preliminary scheme for determining and placing the proper views for complete manufacturing information.

A number of carefully drawn sectional views depicting various ideas for a hydraulically operated mechanism -- here the designer used colored pencils to clarify the component members.

A large sheet with approximately twenty interpretations of a cam locking mechanism -- here the designer sketched pictorially, the bulk drawn with an economy of line, a few (probably ideas that appeared more promising) drawn orthographically, in detail.

Pictorial sketches of plate glass panels with dimensions and specifications -- drawn on company stationery to include in a letter to a national glass manufacturer.

When the engineering student enters the professional world, his interpretation of a problem with technical sketches will ease his and his supervisor's task. Through the sketch the supervisor can immediately establish the degree to which the newcomer has grasped the principles of the particular problem. Discussion comes direct to weak points -- a good beginning is made before instrument drawing commences.

Three non-graphic means of engineering expression are becoming more and more dominant in everyday practice:

CLAY--to represent actual three dimensions

MOCK-UP-MODELS--to visualize and determine clearances and motion in three dimensions

PIVOTED CUTOUTS--to visualize and analyze the motion of moving mechanisms.

(Continued from page 5)

projection. It would be best for all concerned to use third angle projection, but our foreign friends would not listen to anything of that nature. Of course, there is no reason why we Americans should change to first angle projection; therefore, we should watch the trend, and if international exchange of drawings does continue, then we must include first angle projection in our courses. This however, cannot be done if the time allotted to drawing is not increased.

Furthermore, more emphasis has to be placed upon the study of the basic principles underlying the application of limits and tolerances. Such terms as "press fit", "slip fit", etc., should disappear from engineering drawing and actual desired tolerances should be given, particularly if the drawings are made for foreign destinations.

(6) Production Illustration

Here we have a revived art. Hundreds of artists have come to the aid of engineers. We know that the war has called thousands of people into the various factories who had to have a knowledge of reading drawings. Most of these people had never seen the inside of an industrial plant, much less blue prints. Obviously, production illustration can be credited for the removal of this bottleneck. The value of this tool was - and is - of such great importance that overnight, we might say, the demand for artists could not be filled. So enthusiastic have the people in this work become with this revived art that some of them forget that the production illustration is generally made from an orthographic drawing, and that the orthographic drawing is still the clearest way we have of making a record of the

actual conditions in a structure. There is, however, no doubt that production illustration is here to stay, and rightly so; but just how much of this is to be included in an engineering drawing course?

In many of the industries the departments devoted to production illustration now call their men Graphic Engineers. If this trend continues perhaps some thought should be given to granting degrees in graphic arts. It may well be that the amount of material which should be taught in drawing has passed the point where three or four hundred hours of drafting in an engineering course are sufficient to train the engineer, and that the industries would welcome a person well grounded in the graphic arts as well as the fundamentals of engineering.

In conclusion, engineering drawing is indispensable in peace time as well as war time. Instruction has suffered to a point where a complete overhauling is necessary if a thorough job of training is to be done.

Although many new gadgets will appear after the war to simplify the making of drawings, and improvements will appear in much of the equipment and material used in drawing, nothing will be devised which will contribute to completeness, clearness and conciseness of the information that must go on a drawing. This must come from the individual's mind. Of necessity, therefore, it becomes the duty of the teachers of engineering drawing to do their part in the development of the minds of our embryo engineers, and the duty of the Division of Engineering Drawing of the S.P.E.E.; with the support of the E.C.P.D., to see to it that these engineers get the best methods of instruction.

(Continued from page 23)

3. Validity

Objectively-scored examinations give an instructor a measure of known validity to a greater extent than do most subjectively-scored examinations. For this reason an instructor's grading may be less biased and unfair than it is likely

to be if only drawings are judged.

4. Scope

Examinations of this type can cover a range of subject matter limited only by the instructor's lack of ingenuity.

(Continued from page 27)

DRAWING SUMMER SCHOOL OF S.P.E.E.
OFFICERS OF ADMINISTRATION
June - 1946

Director - Dean A. S. Langsdorf
Washington University

Secretary - Prof. R. W. Bockhurst
Washington University

Chairman of Faculty - R. P. Hoelscher
University of Illinois

Organization of the School - Prof. Justus Rising,
Chairman Drawing Division of S.P.E.E.
Purdue University

The **JOURNAL of ENGINEERING DRAWING** is an example of how our offset printing process can solve the problem of how to publish technical papers, work books, laboratory manuals, and other educational material at lowest cost. No photo engravings or cuts necessary.

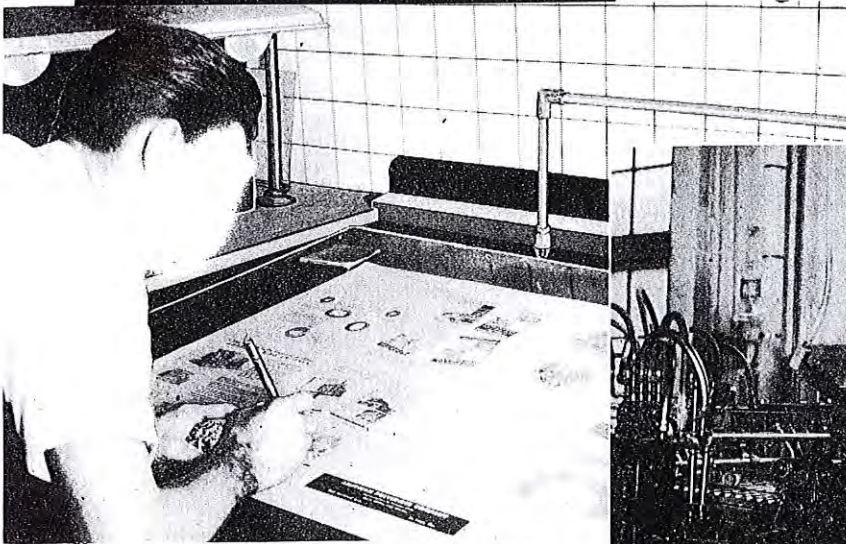

Large Harris Offset presses and thoroughly capable pressmen insure the highest quality of presswork.

● Each plate is carefully inspected and any imperfections eliminated.

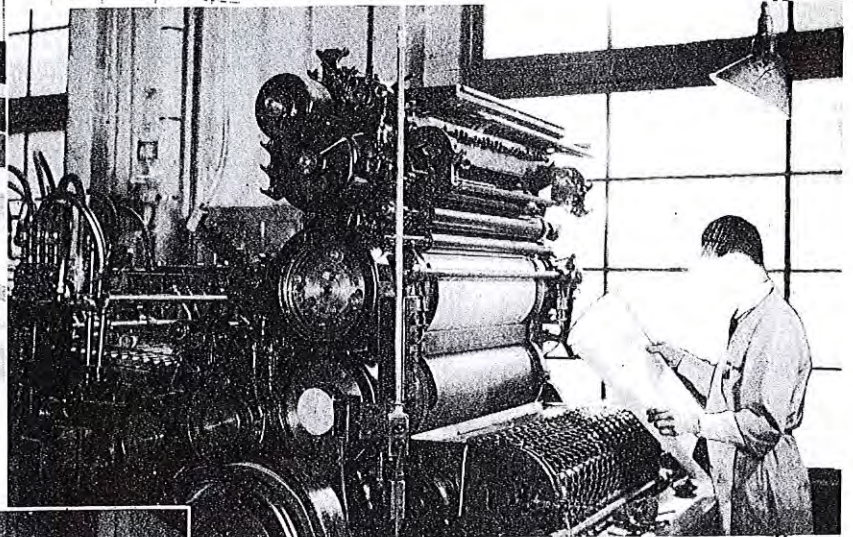

● The latest camera equipment is used to retain all the detail of the original master copy.

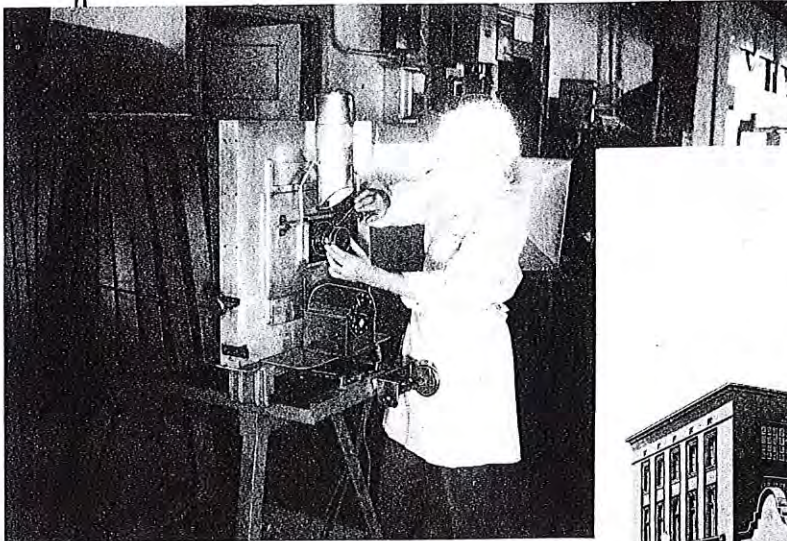

JOHN S. SWIFT CO., INC.
OPERATING PLANTS IN ST. LOUIS-CHICAGO-NEW YORK-CINCINNATI
 2100 LOCUST STREET, ST. LOUIS 3, MO.

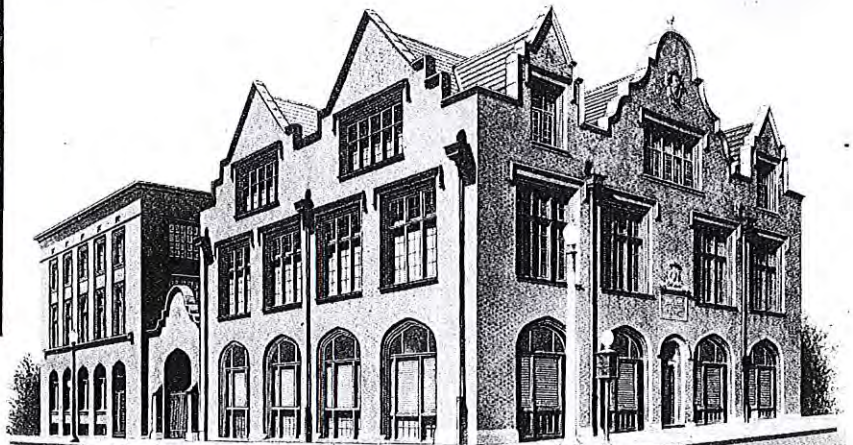

REPORT OF THE BIBLIOGRAPHY COMMITTEE

PROFESSOR H. H. FENWICK, CHAIRMAN
University of Louisville

(For the period November, 1944 to May, 1945)

NEW BOOKS

<u>Author</u>	<u>Title</u>	<u>Edition</u>	<u>Publisher</u>	<u>Year</u>	<u>Pages</u>	<u>Price</u>
Apalategui, J. J. & Adams, L. J.	Aircraft Analytic Geometry	1	McGraw-Hill	1944	283	\$3.00
Coxen, H. H. & Jackson, G. E. & Masters, G. D.	Aircraft Sheet Metal Blueprint Reading	1	American Tech. Society, Chicago	1944	132	2.50
Kenney, J. E.	Blueprint Reading for the Building Trades	1	McGraw-Hill	1944	96	2.00
Musham, H. A.	Maps		Reinhold, New York	1944	228	3.85
Svensen, C. L. & Street, W. E.	A Manual of Blueprint Reading	1	Van Nostrand	1944	98	1.90

	<u>RESEARCH - TITLE</u>	<u>BULLETIN</u>	<u>PUBLISHER</u>
McGuire, J. G.	"A NEW APPROACH TO AXONOMETRIC PROJECTION AND ITS APPLICATION TO SHOP DRAWINGS." (1944) 31 pages	#79	School of Engineering Texas Engineering Experiment Station College Station, Texas

MAGAZINE ARTICLES

Accurate Drafting Instruments - Mod. Plastics, 22:114-Oct. 1944	Griffiths, G. H. - Visual Program of the U. S. Office of Education - Mech. Eng. 66:658-659, Oct. 1944
Allen, A. H. - Gang Scriber Facilitates Accurate Drafting - Mach. Design, 15:123-5, S. '43	Griesbach, H. B. - Draw it in Isometric; Plumbing and Heating Piping Layouts - Dom. Eng. - 164:92-5, Ag. & 94-6, S. 1944
Batley, A. - Use of Sensitized Metal in Engineering Design - Chem. & Ind. - :399 Nov. 18-1944	Hardy, E. - Engineering Drawings microphotographed by Navy Dept. - Iron Age - 154:128, Oct. 12, 1944
Bower, C. T. - Repairs and Maintenance, Drawings for Repair Work - Mech. Handling, 31:366-370 Ag. 1944	Hood, G. J. - Perspective Views by Photography - Jour. of Eng. Dwg. 34:17, 18, My. 1944
Bush, Geo. F. - Notes on Practical Perspective - Journal of Eng. Dwg. 34: 11-16 My. 1944	Lighting Drafting Rooms - Ry. Mech. Eng. 118: 539-540, N. 1944
Drawings Printed on Metal with Layout Paint - Iron Age - 154:58 Nov. 9, 1944 also Mach. 51:170-1 N. 1944	Moloney, D. D. - Simple Marking Devices Speed Drafting Operations for Plan & Profile Surveys - Eng. N. 133: 376 Sept. 21, 1944
Pierce, L. L. - New Machine Assures Drawing Accuracy; Mechanically scribed grid lines for Master Layout Drawings - Aviation 43:148-9. S. 1944	Sketch Book of Design and Detail - Aviation 43:197-Je. 201-Jl. 197-Ag. 183-S. 197-0. 201-N. 1944
Rule, J. T. - Stereoscopic Photography - Mech. Eng. 66:729-30, N. 1944	Trimetric Drawings; Use of Martin Axonograph - Arch. Forum 81:16 Jl. 1944
Sahag, L. M. - Engineering Projection Applies to the Solution of Forces in Space - Jour. of Eng. Dwg. 34:26, My. 1944	Worsencroft, R. R. - Orthographic Theory in Perspective Drawing - Jour. of Eng. Dwg. 34: 7-10 My. 1944

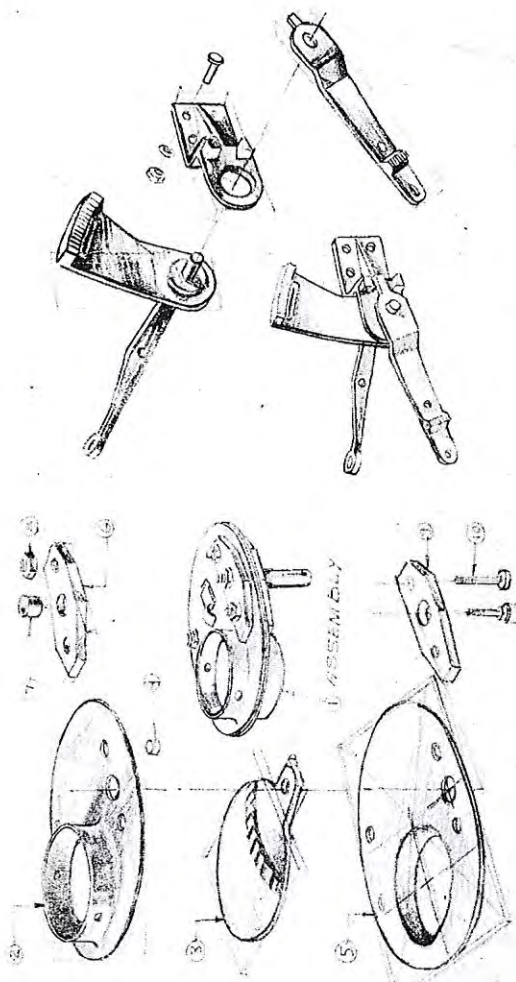

Fig. 2. These pictorial sketches were drawn after the basic studies were completed. This typical application helps to gain an exact overall visualization for the engineer. Design features may be added, and other changes made, as the design progresses. This "ploded" type of presentation facilitates a natural analysis for assembly and installation problems. Too often the young engineer minimizes or neglects the all important phase of manufacturing and costs; this type of sketching (though crude) is a step to rectify the condition.

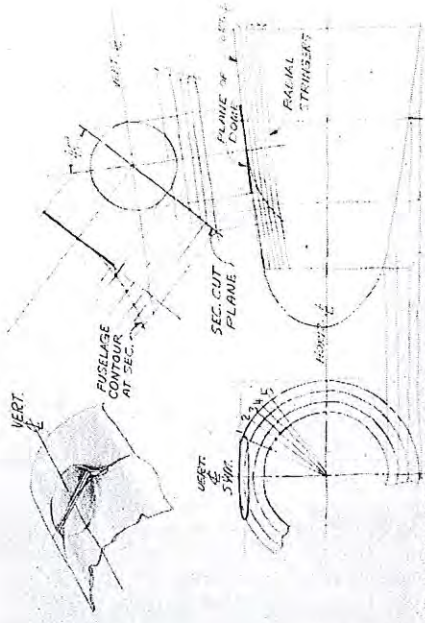

Fig. 1. This drawing was sketched by the engineer over the Joffmann's bench in the experimental shop. It is a graphic explanation to a question pertaining to the development of fillet templates to facilitate the construction of a wood model. This type of technical sketch serves best when drawn in the presence of the workman. The sketching steps are the same as the procedure of a mutual over-all visualization of the problem, the small pictorial sketch in the left hand corner was drawn first. It is interesting to note that although the blueprint might receive careful manufacturing process, caused by engineering work many transpire during the design changes, planning and scheduling requirements, etc. Problems and solutions to these conditions are presented in the form of technical sketches, carried from shop to engineering by the liaison department.

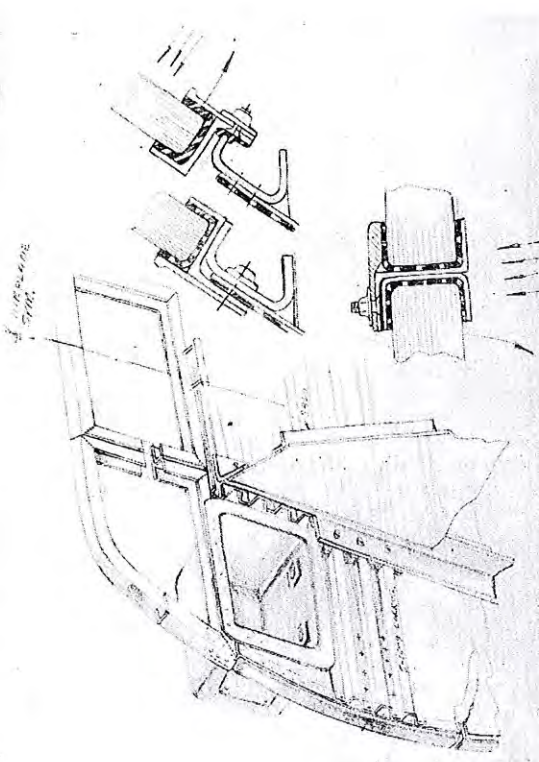

Fig. 4. This rough design sketch is a typical approach to "getting the idea on paper". The flexibility and maneuverability of the sketching medium allows for a variation of solutions in the most rapid manner. The writer feels strongly that the basic thinking hastens the solution and considerably cuts engineering costs.

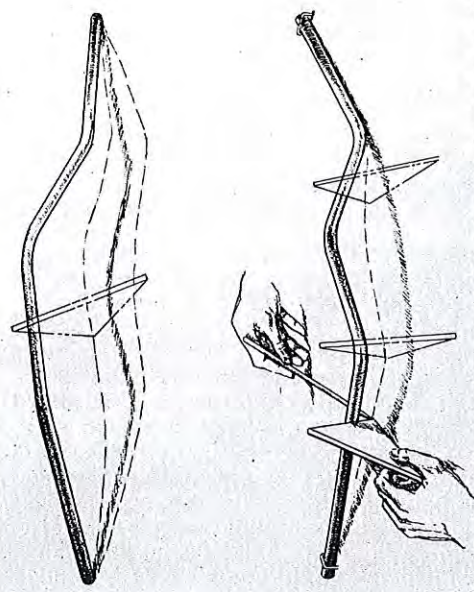

Fig. 3. One of the many mechanical aids used to obtain information on certain technical sketches is illustrated in the method of recording the shape of a tube used in the installation in the airplane. The tube is secured to the fuselage on one side, the base of the triangle resting flat on the sketch paper. Small dashes are drawn at the base of the triangle as it is gradually moved along the length of the tube (bottom figure). A second orthographic view of the tube is drawn (top figure). To represent the outside edge of the tube, the acquired lines of course are added. The diameter and centerlines are added.

OBJECTIVELY SCORED DRAWING TEST PROBLEMS

by

DR. MAURICE R. GRANNEY
Assistant Professor of Engineering Drawing
Purdue University

The problem of the desirability of constructing engineering drawing tests which can be objectively scored is confronted frequently. The effectiveness of such tests, the scope of subject matter which they can cover, the types of problems, the methods of indicating answers as well as of scoring, are parts of the problem. The purpose of this paper is to review some of the findings which have resulted from studies of this question.

I

When writing about tests, it is desirable, as well as necessary, to use certain basic statistical terms. In order to clarify the thinking of some readers whose major interest is not in the field of statistics, two of these terms, reliability and validity, are defined here. The first of these, reliability, is concerned with the consistency with which a job is done. A measuring instrument which has a high coefficient of reliability is one which consistently gets the same result when measuring the same thing. Conversely, a measuring instrument which obtains inconsistent results is one which has a low coefficient of reliability. Most common measuring instruments such as thermometers, scales and pressure gages are very reliable. This can not always be said for scholastic examinations. The dependence of many persons, naively placed as it is, upon tests which indicate the extent of knowledge or ability possessed by a subject, is seldom justified. A different, though related, use of the term reliability deals with the consistency of the grader. Whenever tests, or daily classroom drawings, are graded subjectively, the reliability of the grader is called into question. It is worthwhile to point out that when tests are scored objectively, the reliability of the grader ceases to be a factor influencing the grade.

The second statistical term with which we are concerned is validity. A coefficient of validity is used to indicate the extent to which a test actually measures that which it purports to measure. Again, making reference to common measuring instruments, it can be said in general that they are highly valid if used to do the job they are designed to do. A reliable thermometer, for example, is a valid instrument for temperature measurement. It is invalid, however, for certain other kinds of measurement. Obviously a thermometer would be invalid to measure weight, distance or volume. The causes of validity are occasionally somewhat obscure because only an indirect relationship exists. Most people recognize the relationship between atmospheric pressure and

altitude. Thus, a measuring instrument, if properly calibrated, may actually measure pressure, yet validly indicate altitude. Indirect measurement of this type is sometimes used in tests of mental abilities or manual skills.

In so far as most subject matter tests are concerned, indices of validity may be computed, not only for the tests as a whole, but also for each item in the tests. A reasonable, though sometimes inaccurate, judgment to make about a test is to assume the validity of the whole test, if it has been composed by a qualified person. The assumption in such a situation is that whatever the qualified teacher designates as the proper subject matter of a test is, per force, the subject matter. When such an assumption is made, individual test items may be validated with reference to the whole test. This technique of validation is important at present because a number of sample problems included in this report have been so validated.

A knowledge of the reliability and validity of a test makes for its intelligent use, and for the intelligent interpretation of results obtained by such use. It does not follow that a test for which such information is available is thus better than a test for which the information is lacking; it does follow, however, that when such information is not available for a test, there is little justification for using the test.

II

The most common type of objectively-scored test item is the true-false statement. While this type of test item may be effective in many instances, its use, value, and limitations are so generally known that a further discussion of them here is not required. A second type of verbal test item which may be objectively scored is the multiple-choice statement involving a four or five choice selection. This, too, has received a wide use and is commonly understood. In the opinion of the writer both of these have definite inherent limitations. The following selected samples of non-verbal, objectively-scored test items illustrate an approach to drawing test construction that circumvents a number of these limitations.

In all of the problems presented use has been made of a universal answer sheet like the one shown in Figure A. When such an answer sheet is used, care must be taken to design problems which have the answers numbered rather than the questions. It is assumed that most readers will recognize the possibility of having students mark answers directly on the question folder. Such a practice is quite satisfactory

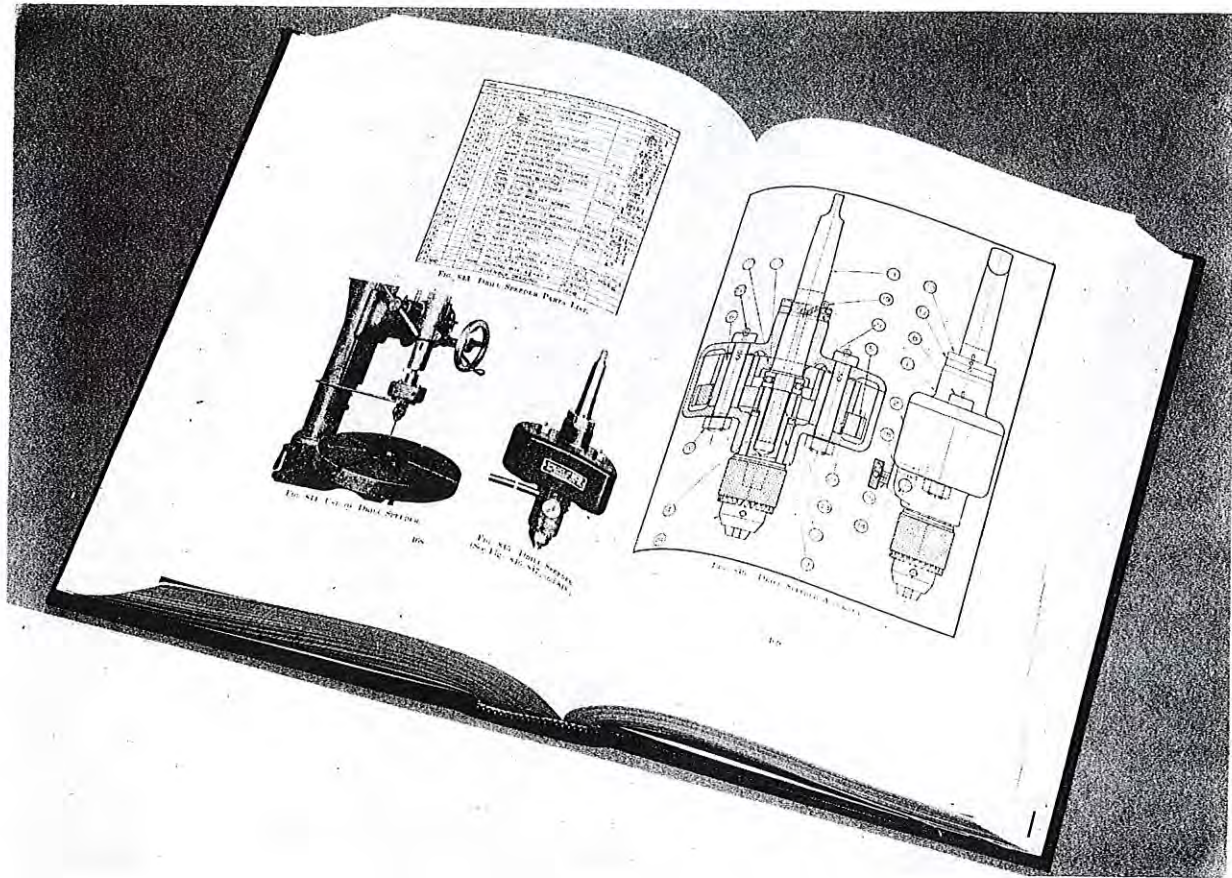

TECHNICAL DRAWING

By Giesecke, Mitchell & Spencer

Manuals

TECHNICAL LETTERING

By DeGarmo & Jonassen

Oblique Lettering Edition \$1.00

Vertical Single Stroke Edition \$1.00

Coming

AIRCRAFT DRAFTING

By Hyman Katz

MAKING PATENT DRAWINGS

By Harry Radzinsky

"A comprehensive treatment of the science of technical drawing arranged logically, and containing a large group of practical problems which afford a highly flexible aid to the teacher in the development of his subject."

—*The Draftsman.*

"Best book on its subject—most thorough, complete, and detailed . . . Excellent sourcebook for men now polishing up to undertake defense drafting jobs but who feel a bit shaky."

—*Scientific American.*

"For the student architect and the draftsman here is a real text book for the working library . . . will lead to finished drawings reflecting the best type of workmanship."

—*Architect and Engineer.*

687 pages. Illustrated. \$3.00

TECHNICAL DRAWING PROBLEMS provides a comprehensive series of problems on all aspects of technical drawing including lettering exercises. \$2.25

Lettering Exercises may also be obtained separately for 60c a set.

The text is now provided with a new chapter on aeronautical drafting by H. C. Spencer and C. Merrell.

THE MACMILLAN COMPANY
60 Fifth Avenue New York 11

in so far as the test itself is involved. It does, however, entail a greater burden in grading. Whenever a large number of students are tested, the universal answer sheet, which can be scored by an untrained person, or by machine, is an excellent device, not only to save time but to reduce cost as well. When the answer sheet is used, the question folder may be preserved for reuse for an indefinite period.

Likewise, in all the tests in which the following samples were used, the tests were scored on a right-minus-wrong basis. It should be clear to the most casual reader how inadvisable it would be to grade only on the basis of right answers in an objectively-scored examination where the student is permitted to mark freely most, or even all the answers if he should so choose. Because the student's grade is lowered to the extent to which he marks wrong answers, the tendency to omit items about which the student is in doubt is very prevalent. For this reason the percent of students who answer each of the test items is a significant aspect of the apparent difficulty of the items. This information is supplied for all sample problems presented in this paper.

It should be pointed out also that a critical index of validity was arbitrarily determined in analyzing the merit of each test item studied. Without resorting to too much detail, it may be said that if a test item was for the most part marked correctly by students who did well on the test, yet marked for the most part incorrectly by students who did poorly on the test, the test item was considered valid.

Most of the test items presented here were chosen not only because they represent

Table with columns: SCORES (1-10), STUDENT NAME, FILE NO., DATE OF BIRTH, AGE, SEX, SCHOOL, CITY, STATE, DATE, NAME OF TEST, GRADE OR CLASS, INSTRUCTOR. It contains a grid of data points for various test items.

Fig. A

Below are shown five ways of sectioning the standard object. Check each of the five ways. If a set of two views is correct in every detail fill in on the ANSWER SHEET the area whose number corresponds to the number opposite "T". If incorrect fill in on the ANSWER SHEET the area whose number corresponds to the number opposite "F".

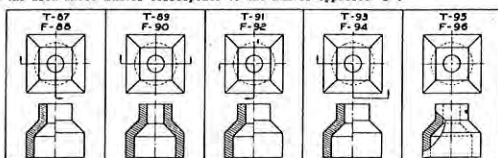

Fig. C

the scope of this testing technique, but also because they proved to be valid as defined by this criterion. It may be said the test items were valid because they served to separate the good students from the poor. Occasionally a test item which did not meet the established validity criterion has been included. In each such case this fact is indicated.

Figures B, C, and D are representative test items which sample a student's knowledge on the identification level.

The selection in Figure B was taken from the first quiz given a group of first term students in elementary drawing. Fifty-three percent of the students who took the quiz tackled this problem. There were 22 correct answers, 21 of which were for items which proved to be valid. Figure C was taken from a later quiz during the same term. Sixty-six percent tried it and all of the items were valid. Figure D represents two possible ways to test the same information. In the upper part of the figure each side view requires a mark, whereas, in the lower part, only the side views which are consistent with the given top and front views should be marked. Although the items are valid in either method of presentation, there is a tendency for a higher percentage of students to try the "true-false".

The next group of selected problems which should be considered together embraces Figures E, F, G, H and I. In this group are problems that are alike in that they attempt to sample a student's functional use of knowledge he possesses. The type of problem shown in Figure E, while excellent because it samples an unique ability, is undesirable because it requires such complicated instructions. For this reason students shy away from it. Another approach to

Several, one, or more of the words in the table below may apply to each of the accompanying lettered diagrams. Select those which apply to each diagram and indicate your choice by crossing out the appropriate number in the table. For example, if A is a polygon and a quadrilateral, cross out 160 and 171 in the table. Transfer your choices to the ANSWER SHEET.

Table with columns labeled A through O and rows listing geometric shapes: Chord, Circle, Semicircle, Hyperbola, Parabola, Parallelogram, Parallelogram, Polygon, Prism, Pyramid, Quadrilateral, Rhombus, Sector, Segment, Trapezoid, Trapezoid, Triangle.

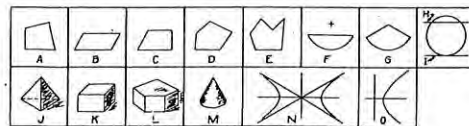

Fig. B

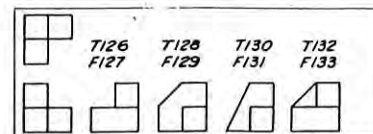

Fig. D

To the right of each two-view drawing below, are three pictorial drawings. Select the pictorial drawings representing the same object as the two-view drawings. If the visible portions of the pictorial drawings are correct assume the invisible portions to be correct also. Indicate your choices by marking the key number appearing in the chart below. Also indicate your responses to the other questions in a similar way. Transfer these numbers to the corresponding numbers of the ANSWER SHEET.

	A	B	C	D	E	F	G	H	J
Represents the same object as the two-view drawing.	210	211	212	213	214	215	216	217	218
Does not represent the same object as the two-view drawing.	219	220	221	222	223	224	225	226	227
Is an isometric drawing.	228	229	230	231	232	233	234	235	236
Is an oblique drawing.	237	238	239	240	241	242	243	244	245
If this figure represents the same object as the two-view drawing to the left.	246	247	248	249	250	251	252	253	254
Line X shows in its true length.	255	256	257	258	259	260	261	262	263
Line X shows shorter than true length.	264	265	266	267	268	269	270	271	272
Line X shows longer than true length.	273	274	275	276	277	278	279	280	281
Line Y shows in its true length.	282	283	284	285	286	287	288	289	290
Line Y shows shorter than true length.	291	292	293	294	295	296	297	298	299
Line Y shows longer than true length.									

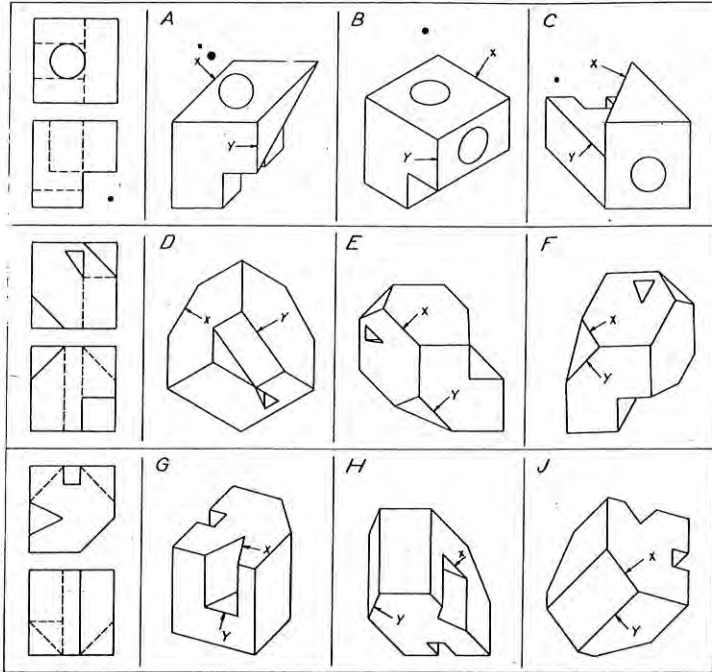
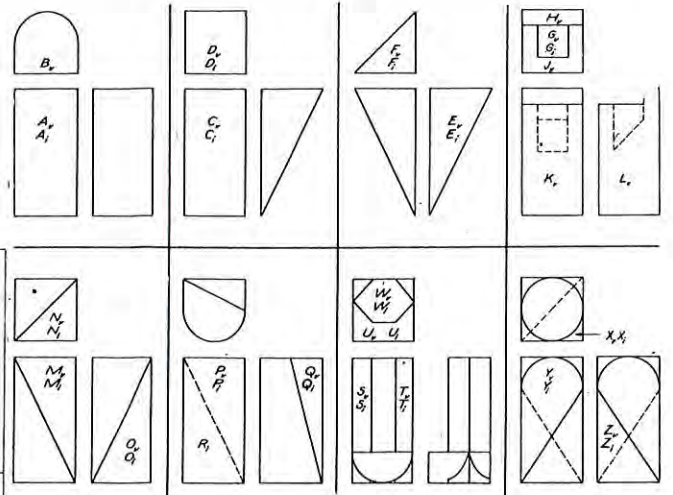

Fig. E



In each compartment above is a three-view drawing of an object. Certain surfaces of the objects are lettered. Visible surfaces are designated by a capital letter with the subscript, *v*; invisible surfaces by a capital letter with the subscript, *i*.

- Below are statements relating to the lettered surfaces. Select those statements which are correct, and indicate your choices by filling in the appropriate areas on the ANSWER SHEET.
- 571 A_1 and A_2 are parallel.
 - 572 A_1 is a cylindrical surface.
 - 573 A_2 is a cylindrical surface.
 - 574 A_3 and B_3 are parallel.
 - 575 C_1 and C_2 are parallel.
 - 576 D_1 and D_2 are parallel.
 - 577 C_1 is a conical surface.
 - 578 C_2 is a cylindrical surface.
 - 579 D_1 is a plane surface.
 - 580 E_1 and F_1 are at right angles to each other.
 - 581 E_2 and F_2 are at right angles to each other.
 - 582 E_3 and F_3 are parallel.
 - 583 E_1 and F_1 are parallel.
 - 584 E_1 is a conical surface.
 - 585 G_1 and G_2 are parallel.
 - 586 H_1 and J_1 are in the same plane.
 - 587 G_1 and K_1 are at right angles to each other.
 - 588 G_1 and K_2 are at right angles to each other.
 - 589 G_1 and K_3 represent the same surface.
 - 590 M_1 and M_2 are parallel.
 - 591 M_1 and N_1 are at right angles to each other.
 - 592 O_1 and M_1 are at right angles to each other.
 - 593 O_1 shows as an edge in the front view.
 - 594 M_1 shows as an edge in the top view.
 - 595 P_1 is a cylindrical surface.
 - 596 P_1 is a conical surface.
 - 597 P_1 and Q_1 are at right angles to each other.
 - 598 Q_1 and R_1 are at right angles to each other.
 - 599 P_1 and Q_1 represent the same surface.
 - 600 S_1 and T_1 are parallel.
 - 601 V_1 is a plane surface.
 - 602 S_1 and U_1 are at right angles to each other.
 - 603 W_1 is a cylindrical surface.
 - 604 U_1 is a cylindrical surface.
 - 605 X_1 is a spherical surface.
 - 606 X_1 is a conical surface.
 - 607 X_1 is a cylindrical surface.
 - 608 Y_1 and Z_1 are parallel.
 - 609 Y_1 and Z_1 are at right angles to each other.

Fig. F

When the Milling Tool details represented below are examined, surfaces indicated by numbers in rectangles will touch surfaces indicated by numbers in circles. Place opposite each number in the table the number of its mating surface together with the size of these two. On the Answer Sheet, mark the numbers corresponding to these sizes.

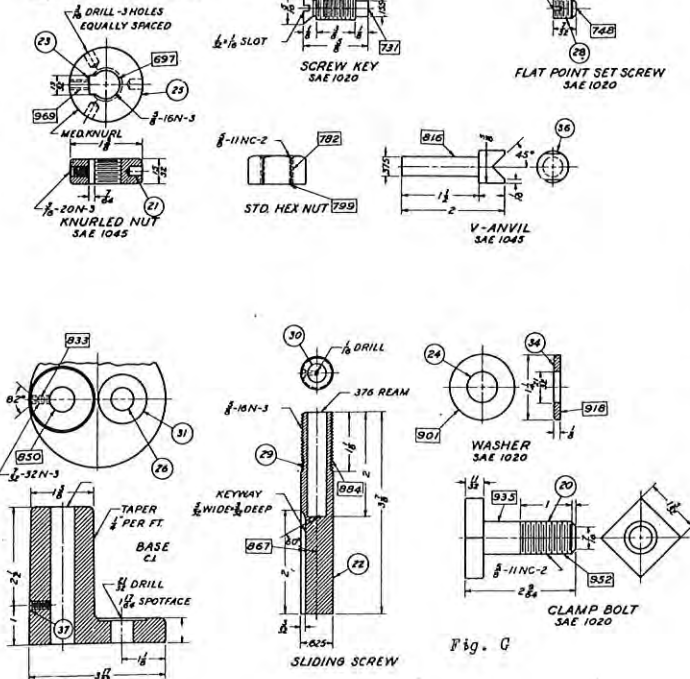

Fig. G

In the dimensioning problem below, select from the dimensions shown those which represent good practice in dimensioning and which would be used in dimensioning the object. Indicate the preferred dimensions by filling in on the ANSWER SHEET the areas corresponding to the numbers of the dimensions selected.

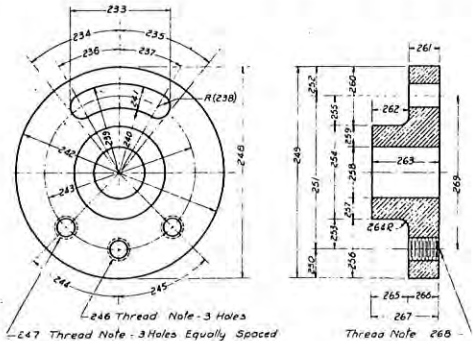

Fig. H

	SUM
20	
21	
22	
23	
24	
25	
26	
27	
28	
29	
30	
31	
32	
33	
34	
35	
36	

testing a related ability of about equivalent difficulty is shown in Figure F. Here the results are somewhat better, in spite of the fact that the instructions are quite involved. In this same group may be included the type illustrated by the problem shown in Figure G. All items in this sample are valid, as is customarily the case with this kind of problem. This particular problem was used late in the second term of general engineering drawing when the topic of assembly drawing was the phase of subject matter being tested. It should be pointed out that even though the numbers of the mating surfaces must be added to determine the answers, students work the problem as freely and correctly as when such an intermediate step is not required. Apparently the ability to follow rather complicated instructions and the ability to solve problems of this type are highly correlated.

Figures H and I represent additional samples of problems in the "functional-use-of-information" group. The problem in Figure H is the more elementary, and may be used earlier in a course than the problem in Figure I. In the latter a more realistic situation exists in that the student must consider the sequence of manufacturing operations before he determines the necessity for and the correctness of any dimension. Problems of this type are seldom omitted by students. They do contain, however, certain invalid items in many instances. Of the 14 correct answers scored for the problem in Figure H, 3 were not valid, of the 15 in Figure I, 4 were not valid. Such is frequently the case in dimensioning problems because of the student's (and the expert's) belief that there exists more than one "best way" to do a dimensioning job.

The third and last group of sample problems included in this report may be considered together because they test a student's manipulative ability as well as his knowledge. In this group are the Figures J, K, L and M.

The scaling test shown in Figure J must be drawn and printed with accuracy. Practically all students will try a problem of this type on any test, and generally the items are highly valid. In this particular case all of the 8 items were valid. A problem such as this, of course, would come early in the first term of a drawing course.

In Figure K is illustrated a type of problem which has proved very effective. The student is called upon to convert a regular front view into a section view, and then is questioned about it. Relatively few students will sidestep a problem of this type. For the specific problem shown in Figure K, all 24 items are valid.

In the opinion of the writer the type of problem illustrated in Figure L, if properly designed, is the most effective of any objectively-scored problem so far devised for examinations in engineering drawing. Such problems not only call upon the student to perform, but test his over-all knowledge of

much of the subject matter as well. Problems of this type can be constructed so that the student must use any or all of his drawing equipment with the exception of instruments for inking. They can involve various phases of the subject matter including pictorial drawings, geometrical constructions, sectional views, auxiliary views, and even intersections and developments, as is illustrated in Figure M. It must be mentioned, of course, that extreme care must be exercised in the preparation of such problems. Presumably the reader will recognize the possibility of designing a program by placing answer circles in the scattergram at carefully selected points so that the test may discern whatever critical information is desired. In the problem illustrated in Figure L there are 40 correct answers. Of this number 6 proved to be invalid. A further refinement of this test problem quite probably could eliminate the 6 invalid items. Such refinement is a phase of test construction which is common to all objectively-scored tests, just as it is to all subjectively-scored tests.

III

In concluding this article a few general statements may be made regarding objectively-scored tests of the type discussed.

1. Reliability

- a. Errors in judgment about what is a correct answer are non-existent in so far as the grader is concerned. For this reason he should make no variation from paper to paper and can grade with perfect reliability. Such a statement scarcely can be made for subjectively-scored examination questions.
- b. The internal consistency of the examination, if it is wisely constructed, can be extremely high. Coefficients of reliability based upon split-half correlations, and upon equivalent-form correlations have ranged from about 0.91 to 0.98 for examinations like those from which problems in this report were selected. Such coefficients have been determined from random samples of about 200 students selected from a total population of about 1200.

2. Knowledge vs. Skill

The aspect of drawing ability measured by these tests is related to but is different from the ability to make a drawing of high-quality linework. Other studies (which shall be reported at another time) indicate that the two abilities correlate to the extent of about 0.62. It is fair to assume that quality of linework, independent of other factors, is an inadequate measure of a student's ability in engineering drawing. Objectively-scored examinations yield some basis for substantiating an instructor's evaluation of student ability.

(Continued on page 15)

Quality....



DRAWING MATERIALS

DRAWING INSTRUMENTS
IN SETS

DRAWING AND
TRACING PAPERS

WATERPROOF
DRAWING INKS

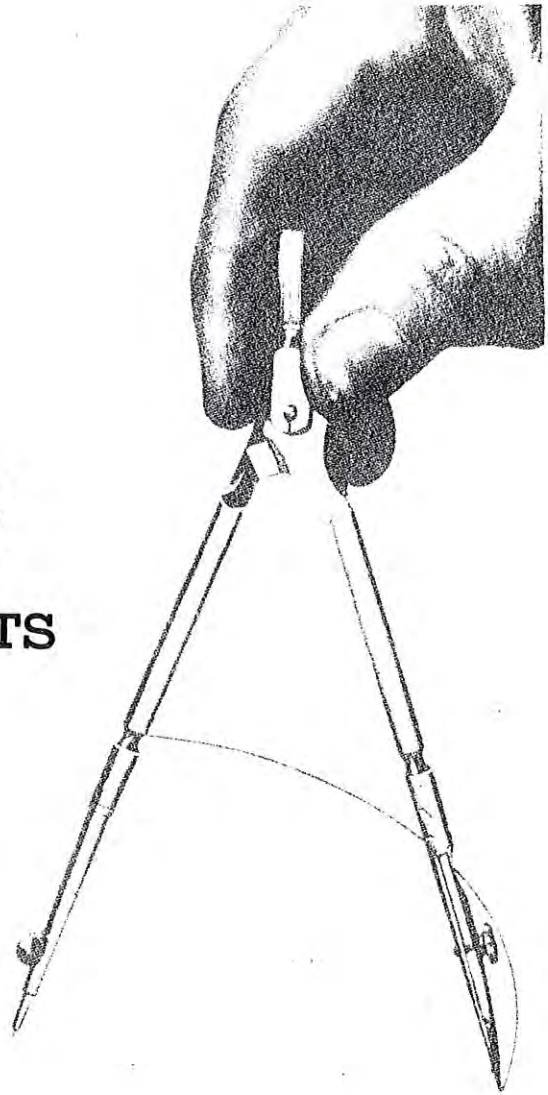

STUDIO, SCHOOL AND
DRAFTING ROOM FURNITURE

Catalogue, Vol. 700, on Request

F. WEBER CO.

FACTORY ADDRESS:
1220 BUTTWOOD STREET
PHILADELPHIA, PA.

Branches:

705 PINE ST., ST. LOUIS, MO.
227 PARK AVE., BALTIMORE, MD.
1621 CHESTNUT ST., PHILA., PA.

Consider the manufacturing operations described for the objects shown below, and select from the given dimensions those which represent good practice. Transfer the numbers of these dimensions to the Answer Sheet. Note that the drawing may not show all necessary dimensions.

THROW-LEVER LINK: The sequence of manufacturing operations is: (1) Forge to outline shape, (2) mill the larger diameter face, (3) mill the smaller diameter face, (4) insert in a jig and drill the three holes, (5) tap the threaded holes.

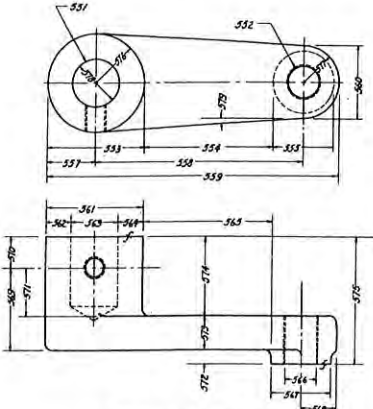

THROW-LEVER LINK

SPECIAL VISE JAW PLATE: The sequence of manufacturing operations is: (1) Forge to outline shape, (2) mill the bottom face, (3) mill the right end (which mates against the vise jaw in use), (4) finish the top and cut notch in one milling operation, (5) drill and counterbore holes.

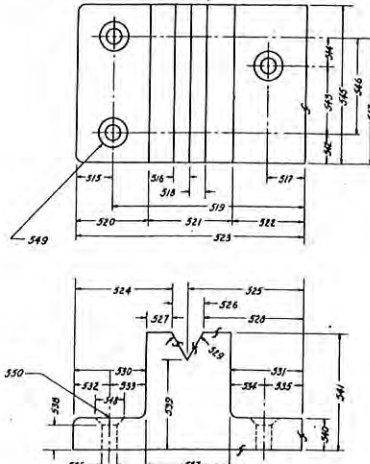

SPECIAL VISE JAW PLATE

Scale each of the eight lines given below to the nearest one-half graduation interval, using the scale indicated above the line. Select and mark on the Answer Sheet the number appearing with the correct scaled distance expressed in correct form.

- 1/4" = 1"
 - 1/4" = 1'-0"
 - 1" = 1'-0"
 - 3/4" = 1'-0"
 - 1" = 50'
 - 1" = 100'
 - 1/2" = 1'-0"
 - 1/2" = 1"
- (185) 5'-8 3/4" (186) 5 3/4" (187) 2'-10 3/4" (188) 2 7/8"
 - (189) 8 2/4" (190) 8 3/8" (191) 8 5/8" (192) 8'-8"
 - (193) 3 2/3" (194) 3'-0 1/4" (195) 4'-0 1/4" (196) 3'-1"
 - (197) 7'-4 1/2" (198) 2 1/4" (199) 2'-5 1/2" (200) 2'-4 1/2"
 - (201) 16'-8" (202) 16'-8" (203) 150/18" (204) 336'
 - (205) 132' (206) 396' (207) 26.4' (208) 26.4'
 - (209) 1 2/3" (210) 1'-4 3/8" (211) 1'4 3/8" (212) 1 1/2"
 - (213) 1 3/8" (214) 1'-4 3/8" (215) 1 1/2" (216) 1 3/8"

Fig. J

Convert the front view into a full section view. Select a cutting plane which will show the object to the best advantage. After the conversion, some of the lines may or may not have changed in character. Also, some of the surfaces will be cross-hatched. Indicate such information for the given lines and surfaces by marking an "X" through the numbers in the proper column. Transfer these marked numbers to the ANSWER BLANK.

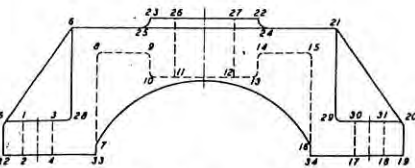
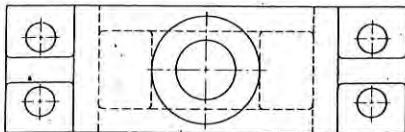

Line	Remains Unchanged	Change to Visible	Should be Omitted	Surface	Should be Cross-hatched	Should not be Cross-hatched
1 - 2	512	513	514	25-27-12-11-25	554	555
3 - 4	515	516	517	6-28-3-1-5-6	556	557
5 - 6	518	519	520	5-1-2-32-5	558	559
6 - 25	521	522	523	1-3-4-5-1	560	561
25 - 11	524	525	526	7-8-9-10-11-12	562	563
11 - 12	527	528	529	12-14-15-16-7	564	565
12 - 13	530	531	532	7-16-24-33-7	566	567
13 - 14	533	534	535	21-12-13-14-15	568	569
14 - 15	536	537	538	16-3-17-30-29	566	567
15 - 16	539	540	541	21-24-22-27	568	569
16 - 17	542	543	544	31-12-19-20-31	566	567
17 - 18	545	546	547	21-29-30-31-20	570	571
18 - 19	548	549	550	21	570	571
19 - 20	551	552	553	5-4-33-7-8-9	572	573
20 - 21	554	555	556	10-11-26-25-25	572	573
21 - 22	557	558	559	6-28-3	572	573

Fig. K

Develop the right half (OABC) of the surface of the cone. Fill in on the ANSWER SHEET the areas appearing with the numbers which correspond to the numbers of the circles through which the outline of the development pass. Do not record the circles through which elements or construction lines pass.

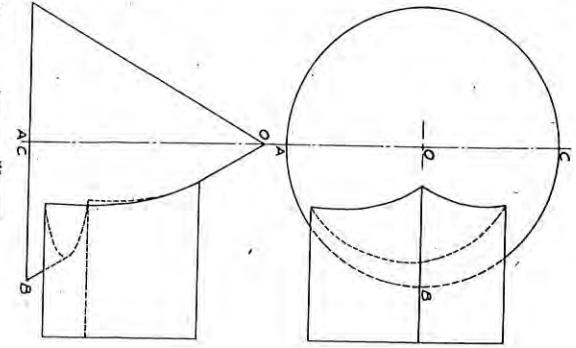
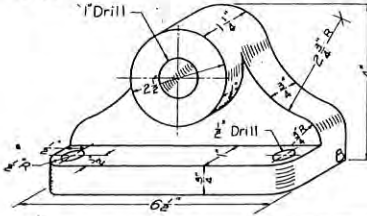

Fig. M

Page 6



Draw the front and top view of the object shown using a FULL SIZE scale. Start your views at the points indicated and be very accurate with your construction and dimensions.

On the ANSWER BLANK fill in the areas whose numbers correspond to the numbers of the circles through which any of the object lines of the drawing (either visible or invisible) pass.

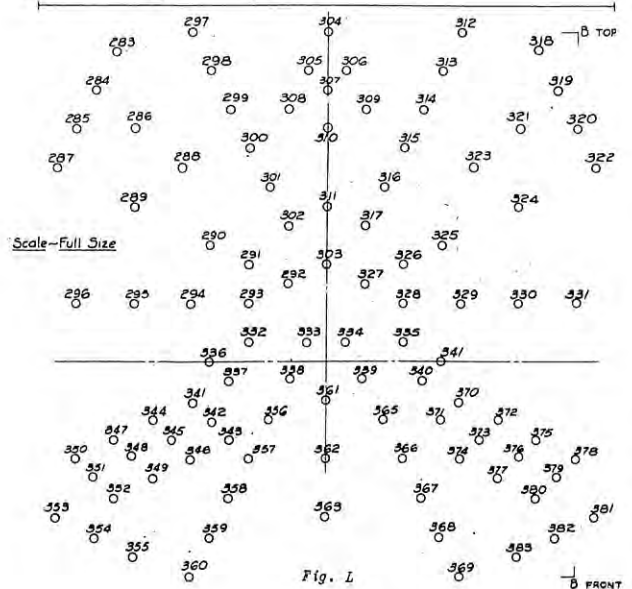

Fig. L

PROJECTIONS

The editor wishes to thank the drawing teachers and officers of the Drawing Division for their many helpful suggestions and assistance during the past year. The assistance of Professors C. H. Ransdell and G. S. Stiles of Texas A. and M. in helping shape material for this issue of the Journal is acknowledged.

Professor Victor L. Martin of Northeast Junior College of L. S. U. at Monroe, La. sent in his subscription accompanied by subscriptions for each of these men: A. S. Gunter, J. S. Holmes, Zilpha McConnell and E. O. Hinton, stating we like the Journal of Engineering Drawing. It is going to help us a lot in our E.S.M.W.T. course sponsored by the U. S. Office of Education.

Professor John W. Kurtz, Head Department of Engineering, The University of Omaha spoke to 75 graduate engineers of the Glenn L. Martin Nebraska Engineers Society January 4 on the opportunities and advantages of belonging to professional Engineering groups.

Professor F. W. Ming, Supervisor Production Engineering War Training, Polytechnic Institute of Brooklyn renews his Journal subscription and makes the following comment: "I want you to know that the project is truly worthy of support and I am glad to know that nearly 100 new subscribers have been added to your subscription list".

Professor B. M. Aldrich of Okla. A. & M. says: "Favorable reports continue to come to the Department of Mechanical Engineering regarding both men and women who completed E.S.M.W.T. courses in Drawing and are now employed in industry. A number of employers have sent samples of drawings completed by trainees and insisted that they would like to employ others with similar training".

Professor Edward J. Dowling, S. J. of the University of Detroit has renewed his and Professor Gerardi's Journal subscription and state "Please be assured of our entire support and deep appreciation of the Journal."

Professor H. E. Grant, The University of Wisconsin in Milwaukee has just supplied the editor with a list of excellent suggestions for the Drawing Journal. Suggestions from all are encouraged and welcomed.

Professor Samuel P. Owen of Rutgers University requests the sending of regular renewal notices so he will not miss any copies of the Journal and states "the magazine as it is, is both interesting and helpful".

Professor L. D. Doty of Cornell University sends the following note: "Sure enjoy the Journal of Engineering Drawing. Please get my name back into the subscribers pot pronto".

Professor Charles Richle, Jr. of Norwood, Ohio sends this note with his subscription money, "The publication is of a great deal of interest to me. Although more space might be devoted to material on the secondary school level." The staff hopes to have more articles by public school Drawing teachers but is experiencing considerable difficulty in securing material. High School teachers please let this be a challenge to help find material and suggest topics and authors for material on the high school level.

Professor Chester Johnston of Eureka, California sent in his renewal subscription before receiving his last current copy stating: "Your Journal is very good so I don't want to be without any copies, I wish they would come more often, let's hope you can do so in the near future."

Professor N. A. Lago of Central High School, Oklahoma City was retired last May after teaching Engineering Drawing 33½ years. He has renewed his subscription to the Journal and is now employed as a Draftsman in the Bridge Department of the Oklahoma State Highway Commission.

NECROLOGY

Leslie David Hayes, Professor of Machine Design and Construction and Head of the Department of Mechanical Engineering, West Virginia University, died October 1, 1944 in Morgantown, West Virginia. He was born in South Stafford, Vermont, March 27, 1876.

Professor Hayes attended the University of New Hampshire, 1893-1898, graduating with a Bachelor of Science in M. E. He received his M. E. degree from Cornell University in 1908 doing advanced work in 1908-1910.

Professor Hayes long teaching career includes high school Manual Training from 1899 to 1907; Instructor and Assistant Professor of Machine Design 1907-1918 Cornell University; Professor of Machine Design and Industrial Engineering 1918-1944 and Head of Mechanical Engineering Department 1937-1944, West Va. Univ.

His practical experience was varied as follows: Bookkeeper, Stafford National Bank, Dover, N. H.; Draftsman, Morse Chain Co., Ithaca, N. Y.; Research Assistant, Experiment Station, Durham, N. H.; Surveying, City of Ithaca, N. Y.; Store Keeper, Construction Dept., N. Y. Telephone Co.; Draftsman, Youngstown Sheet Tube Co.; and Mechanical Engineer, National Bureau of Standards.

Professor Hayes was an active member of: Scabbard and Blade; Pi Tau Sigma; A.S.M.E., Hon. Chr. - Student Branch at West Va. Univ.; S.P.E.E. Membership Com., Vice-pres. - Allegheny Sec.; West Va. Soc. of Prof. Engineers, Exec. Com. and Chr. Program Com. - Morgantown Chapter; Registered Professional Engineer in West Va.; Kappa Sigma; and Rotary International.

His books: Emperical Design; Descriptive Geometry jointly with G. W. Grow; Notes on Kinematics jointly with E. H. Wood. Other writings: The Nature of Rolling and Sliding in Direct Contact Mechanisms; The Design and Use of Twisted Spur Gears; A Modification of Ritter's Formula for Columns; and Emperical Design.

DRAWING SUMMER SCHOOL

The Executive Committee of the Drawing Division of S.P.E.E. met in Chicago on February 10, 1945 and postponed the Summer School for Drawing Teachers until the next annual meeting of the Society. This was necessary because the tentative program prepared in December by the Executive Committee was so interwoven with the annual meeting of the Society that it would have necessitated a new program and time would not permit this change.

Chairman Justus Rising of Purdue wishes to convey to you the following information: "At the February meeting, the Executive Committee made some revisions and modifications in the tentative program, based on developments subsequent to the receipt of replies to our communication of December 19. We have received a considerable number of names as

possible participants in the program and we appreciate them very much but the list is far from adequate. Will you, therefore, examine the program given in February Journal of Engineering Drawing and write in the names of persons able to present or discuss the various papers and return this not later than May 1, 1945? Do not overlook speakers from industry with whose abilities and qualifications you may be familiar." (As the Journal will not reach you until after May 1, please read the program over and send Professor Rising all your suggestions immediately, in case you have not already sent them in. - The Editor.)

"During the summer, the Executive Committee will prepare a semi-final program containing the names of speakers which can receive final action when the Committee meets in the fall to complete their plans for the summer of 1946.

"It appears likely that the next meeting of the Society may be held in St. Louis, since Dean Langsdorf has again extended an invitation to the Society to come to Missouri. The Executive Committee of the Drawing Division hopes the Society will accept, and that the Washington, D. C. ban will be lifted so that the meeting may be held in 1946. Anyway, we propose to continue work on our plans and to complete them as quickly and completely as possible so that the summer school for drawing teachers can be held as soon as conditions are appropriate."

QUOTATIONS

(Selected by Prof. G. J. Hood)

"It is almost unbelievable that in a civilized Europe a nation could ever exist, ruled not by statesmen but by vicious criminals. But Germany is just this type of nation. Should it ever be victorious in its imperialistic aims, it would dictate to other countries whether they should be permitted to live in peace or suffer wars. It is truly pathetic that criminals should rule a people to whom the world once sent its children in their quest for scientific knowledge."

-- written by Georg C. Lichtenberg
German Professor, 1794

"I have often felt a bitter pain at the thought of the Germans. They are so decent as individuals, so wretched as a mass."

-- written by Goethe, 1813

"The Germans have always cherished extravagant dreams for their nation and for themselves. They will plunge into the deepest abyss of error and arrogance in the hope of attaining them. Therefore, periodically, the whole nation may change its spiritual and political faith and the ghosts of an unhappy past will stalk in the land like spirits of the dead. All nations at one time or the other may believe themselves unique and supreme. But eventually boys grow up and become men, whereas the Germans cling forever petulantly to their violent toys of war."

-- written by Franz Grillparzer
Austrian poet, in 1838

(Continued on page 15)

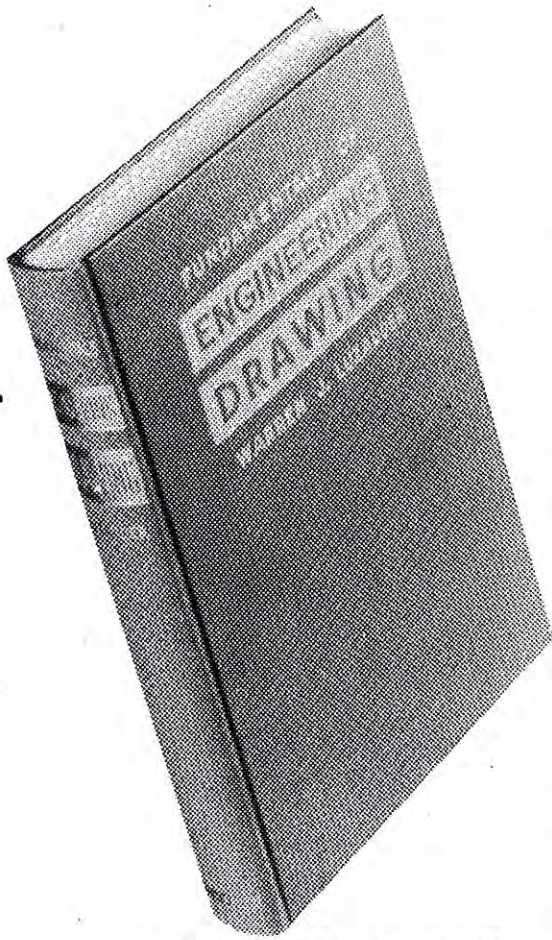

A Self-Teaching Text!

Fundamentals of ENGINEERING DRAWING

By **WARREN J. LUZADDER**

Department of Engineering Drawing, Purdue University

THIS unique text, developed after many years of successful classroom experience in Engineering Drawing at Purdue, employs an entirely new and fresh approach in presenting the subject.

**An
Improved
Teaching
Method**

Unlike many overburdened reference-type texts now in use, the book is written in simple, everyday English. It thoroughly covers all phases of the subject for a well-balanced course in Engineering Drawing. Among other topics, it discusses:

Equipment and Materials and how to Use Them — Instruments — Lettering — Elementary Engineering Geometry — Projection — Sectional Views — Screw Threads and Fasteners — Shop Processes — Machine Elements — Welding Drawings — Patent Office Drawings. Special emphasis has been placed on Dimensioning, Developments and Intersections, and Machine and Welding Drawings — subjects which are not adequately treated in most texts now in the field.

Designed for Easier Learning

In preparing FUNDAMENTALS OF ENGINEERING DRAWING, Professor Luzadder has expressly designed it to meet the problems of the busy teacher of present-day large classes. He has exerted every effort to make the text as self-teaching as possible. This has been accomplished by:

1. Including simple explanations of all the more common difficulties.
2. Using an unusually large number of illustrations throughout the text, particularly in earlier chapters.
3. Putting forth special effort to make each illustration repeat fully in graphical language the ideas presented in the accompanying words.

It is for these reasons that instructors are most enthusiastic about the book and why so many instructors are now using it in their classes. The long list of institutions that have adopted the book includes: *College of the City of New York, Drexel Institute, Hunter College, Indiana University, Texas Christian University, Purdue University, and many others.*

568 Pages 6 x 9 Inches College List \$3.00

PROBLEMS IN ENGINEERING DRAWING

*By Luzadder, Arnold, Bolds, and Thompson, all of
Purdue University*

93 Plates 9 x 11 Inches College List \$3.25

Read What Instructors Say

"good chapter on Dimensioning"

"I feel Luzadder's main contribution to the textbook material on Engineering Drawing is a good chapter on Elementary Dimensioning. Examples of dimensioning are simple, and common shapes as on pages 183 and 202 are of more value to the beginning student than examples of elaborate machine parts." — *Professor Earle F. Watts, Massachusetts Institute of Technology.*

"clearly illustrated and described"

"This is the most comprehensive treatment of technique in the field. Many points usually left to the judgment of the student are here clearly illustrated and described." — *Robert K. McConnell, Instructor in Engineering Drawing, New York University*

"excellent choice of examples"

"Professor Luzadder's clearness of explanation, excellent choice and execution of drawing examples, his practical and often original procedure, his knowledge of the beginner's requirements indicate that he has written a book that meets a real need." — *Professor Horace P. Fry, Department of Mechanical Engineering, University of Pennsylvania*

Send for an Approval Copy Today

Address: 70 Fifth Avenue, Zone 11

PRENTICE-HALL, INC. ★ NEW YORK

ORTHOGRAPHIC PROJECTION AND THE CLOSE FITTING "GLASS BOX"

by

J. G. McGuire
Associate Professor

B. M. Gallaway
Instructor

of

Engineering Drawing
Agricultural and Mechanical College of Texas

The reasoning behind the proper arrangement for the several views of an object according to the American Standard arrangement is often misunderstood by beginning college freshmen. In an attempt to clarify this matter the writers present a modified conception of the "glass box" with the idea in mind that this method of explanation may be used alone or in conjunction with other standard procedures of presentation such as movies, ordinary rule of thumb (top view above the front, right side view to the right of the front, etc.) and the usual "glass box" method.

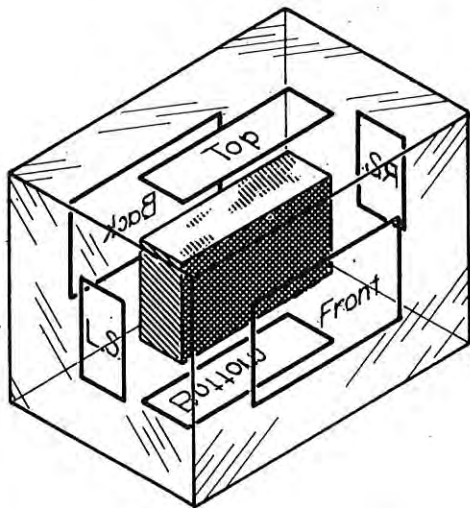

Fig. 1

In Fig. 1 the ordinary "glass box" is shown with the object suspended in the approximate center and projected on the several planes. The good points of this method are admitted; however, it is difficult for many students to visualize the correct relationship of the dimensions of the several views. Whereas, in Fig. 2 the planes of the "glass box" have been compressed to fit snugly about the object, thus minimizing this difficulty. In particular some beginning students have trouble realizing the fact that the top, right side, left side and bottom views have a common dimension. It can be observed that the depth of the object as given by the top view is repeated in the right side, left side and bottom views. The fact to be noted here is that the depth, as shown on these four views, is actually taken from the object itself since the compressed glass box represents the "skin" of the object. The close-fitting glass box is then unfolded in the usual manner as shown in

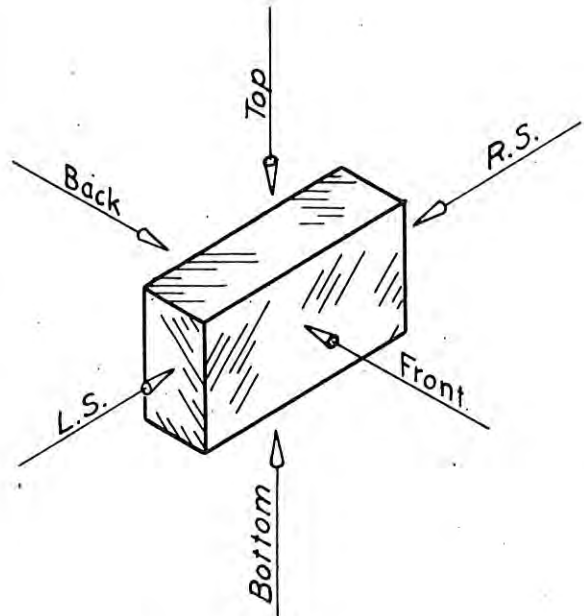

Fig. 2

Figs. 3 and 4. Here the views are knitted together, thus aiding the student in visualizing the identity of the dimensions.

Pictured in Fig. 5 are the six views spaced properly for pleasing appearance and ease of dimensioning. It should be observed that the student may at this point actually cut from paper the arrangement shown in Fig. 4 and fold into a three dimensional object as shown in Fig. 2.

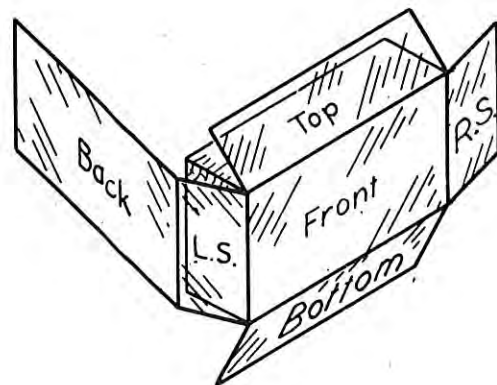

Fig. 3

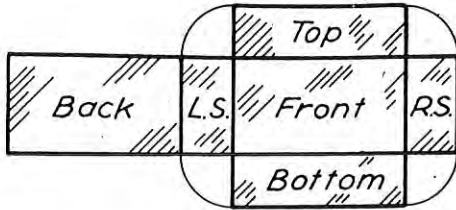

Fig. 4

In Figs. 6 - 9 the same idea is illustrated; however, the object used here is not a rectangular prism. It will be noted in Fig. 6 that the glass box has been extended to form a rectangular prism similar to Fig. 2. The procedure of unfolding and separating is

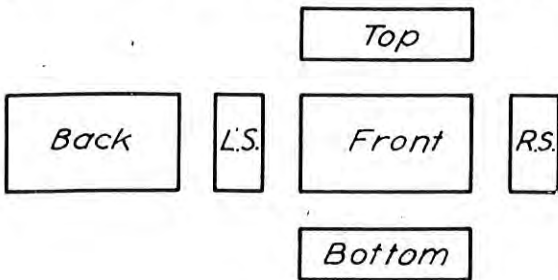

Fig. 5

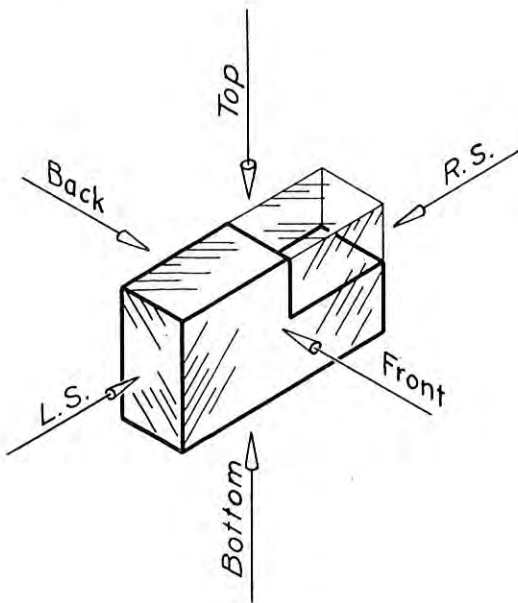

Fig. 6

shown in Figs. 7, 8 and 9 and is, of course, identical to that for Figs. 3, 4 and 5.

The "close-fitting glass box" idea may be presented by blackboard illustrations, as a model, or in chart form.

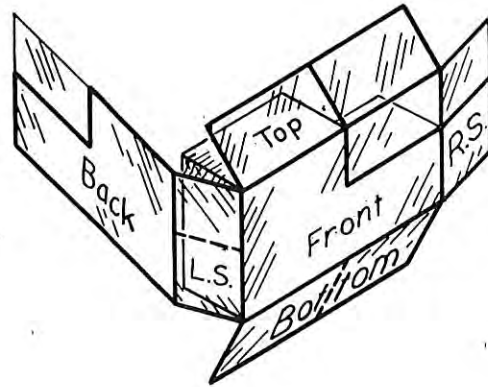

Fig. 7

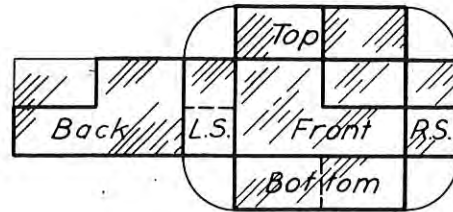

Fig. 8

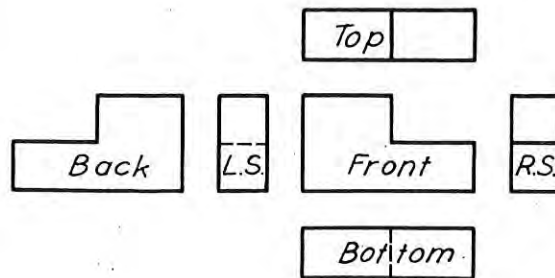
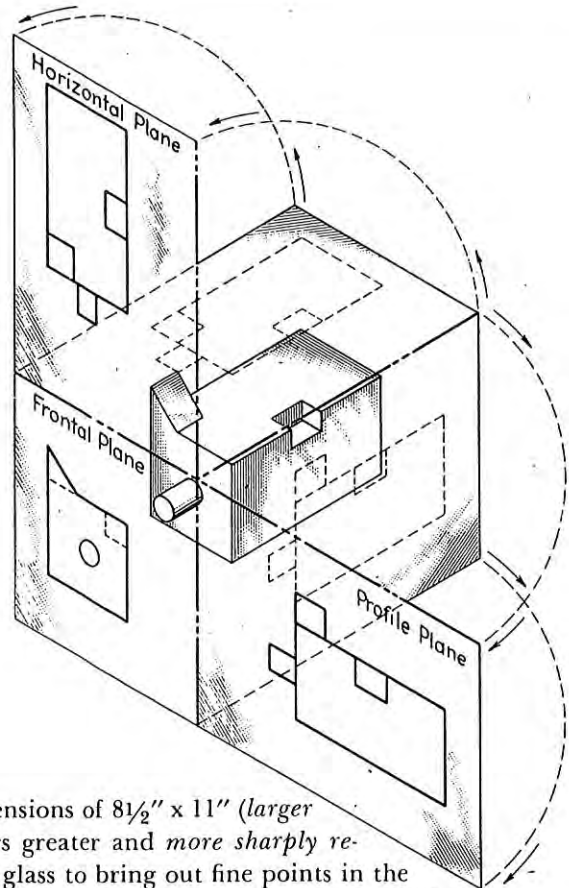
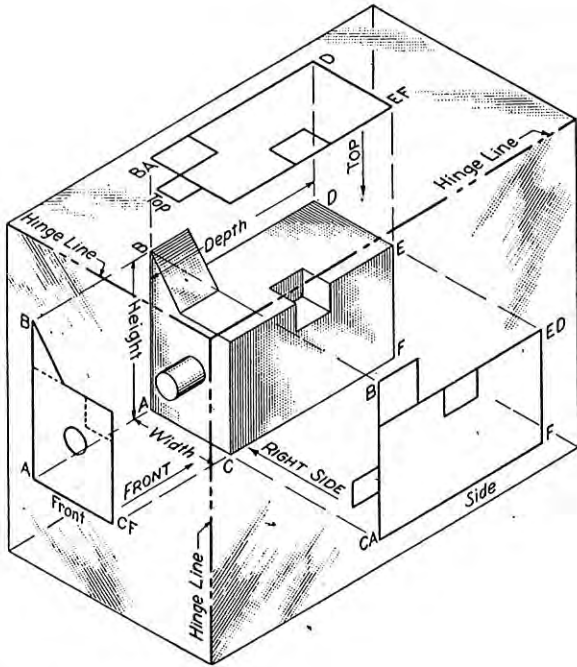

Fig. 9

The LARGER PAGE SIZE in a TEXTBOOK on ENGINEERING DRAWING Gives That Book a *Big* ADVANTAGE in Presentation!



for Example:

Because this Engineering Drawing textbook has page dimensions of $8\frac{1}{2}'' \times 11''$ (larger than most books on the subject), and for this reason offers greater and more sharply reproduced illustrations*—there is no need for a magnifying glass to bring out fine points in the illustrations. Students are enabled to observe and study every detail of the project on which they are working, thus being absolutely sure of their approach to the work. There are 869 splendidly conceived illustrations in this recent book, systematically spaced throughout 462 pages of text matter (the equivalent printed area of 837 pages of the average 6×9 size).

ENGINEERING DRAWING—Practice and Theory

By the late Isaac N. Carter, Associate Professor of Civil Engineering, University of Idaho; and H. Loren Thompson, Assistant Professor, Northwestern Technological Institute. This book is now in the **\$3.00** Second Printing of the New Second Edition.

PROBLEM BOOK AVAILABLE—160 plates, $11 \times 8\frac{1}{2}$, paper bound, perforated—\$2.25

ORDER an examination copy on approval. Take your time to inspect this splendid book. Observe the many features that make for clearer presentation of the complex layout. **ENGINEERING DRAWING** more successfully meets the needs of students for a textbook presenting fundamental elements of engineering as outlined in conventional courses of Engineering Drawing, Descriptive Geometry and Machine Design.

INTERNATIONAL TEXTBOOK COMPANY—Scranton 9, Pennsylvania

*(Note: Illustrations shown above taken from Carter and Thompson's Engineering Drawing, are actual size)