

The Journal of Engineering Graphics

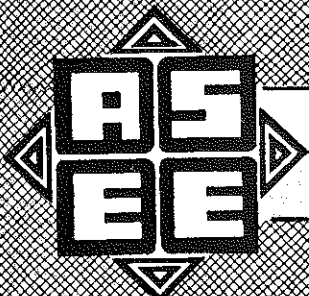

FALL 1964

SERIES NO. 83, VOLUME 28, NUMBER 3

PUBLISHED BY THE DIVISION OF ENGINEERING GRAPHICS · AMERICAN SOCIETY FOR ENGINEERING EDUCATION

DRAFTING TRENDS

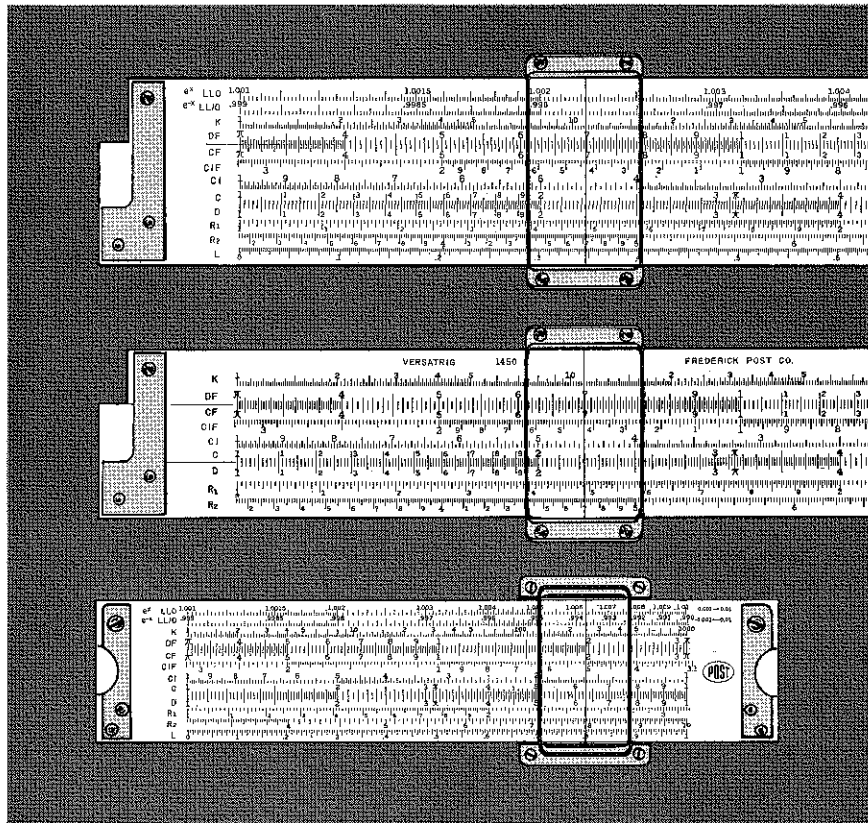

Some of the modern POST slide rules that do more work for you are Versalog, top, Versatrig, middle, 5" Pocket Versalog, bottom.

Modern slide rules give you faster solutions, greater accuracy

Keeping pace with modern engineering mathematics, new slide rules have been developed to speed calculations and offer greater accuracy. Scales have been improved for quicker solutions. Precision-cut markings offer greater accuracy and easier, faster reading.

Restricted by your slide rule's limitations?

Your present slide rule may be slowing your calculations to horse and buggy speeds. It should have scales that cover the four basic functions: (1) multiplication and division; (2) roots and powers; (3) trigonometric operations; (4) common logarithms. If not, you are not making full use of the time-saving short cuts a POST slide rule offers.

Which slide rule will do the best work for you?

POST offers 10" slide rules, 4" and 5" pocket models, circular slide rules,

Chemrules and control engineer's rules with special quadratic scale attachment. All have a lifetime guarantee, and are furnished with complete instructions.

The POST Versalog, developed by professionals for professionals, is often called "the world's finest slide rule." The new Versatrig is for technicians and draftsmen who need an advanced, trig-type rule.

Free information

You can learn which slide rule will work best for you by consulting the POST slide rule selector chart at your dealer's showroom—or, for literature which describes applications for all popular slide rule scales, write Frederick Post Company, 3650 N. Avondale Ave., Chicago, Ill. 60618



engineering and
copying products

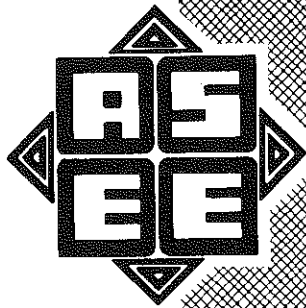

TABLE OF CONTENTS	
ARTICLES	
Descriptive Geometry in the Space Age	9
Vexing Vectors	11
Design and the College Freshman	15
Geometry and Relativity	23
FEATURES	
Editorial	3
Officers Page	8
Perspective	14
DIVISIONAL NEWS	
Division of Engineering Graphics	4
Citation to Luzadder	19
Mid-Year Program	21

EDITORIAL STAFF

Earl D. Black, Editor
 General Motors Institute

Myron C. Mochel
 Advertising Manager
 Clarkson College of Engineering

William B. Rogers
 Circulation Manager & Treasurer
 U. S. Military Academy

Kenneth E. Botkin, Assistant Editor
 Purdue University

Eckhardt E. Sautter, Assistant Editor
 General Motors Institute

Robert J. Christenson, Art Editor
 General Motors Institute

GRAPHIC AIDS IN ENGINEERING COMPUTATION

by R. P. Hoelscher, J. N. Arnold, S. H. Pierce

1963 printing
Published 1952
Price \$5.75



This well-known text of 197 pages, 6" x 9", in hard covers, deals with alignment charts, empirical equations, the design of special slide rules, and the use of the standard slide rule. Examples are numerous, and there are problems at the end of each chapter.

The seven chapters are: (1) Standard Slide Rules, (2) Empirical Equations from Engineering Data, (3) Alignment Charts, (4) Graphical Calculus, (5) Alignment Charts with Determinants, (6) Special Slide Rules, (7) Movable-scale Nomographs.

Formerly available from McGraw-Hill; now a Balt book.

CREATIVE PRODUCT EVOLVEMENT

by J. Liston and P. E. Stanley

Published 1964
Price \$5.00

This timely text of 190 pages, 8-1/2" x 11" page size, in durable plastic cover, is profusely illustrated with example cases of new-product evolution, and contains a large number of practice problems particularly designed to stimulate imaginative thinking. Probably appropriate for a junior or senior course.

Unique in its field, and particularly emphasizing the methods of synthesis, a step-by-step procedure is presented for conceiving, describing, and proving ideas and proposals for new and better products.

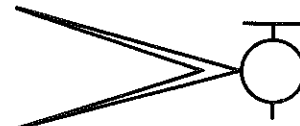

DESCRIPTIVE GEOMETRY PROBLEMS

by S. B. Elrod, C. H. Zacher, H. F. Gerdum

Published 1962.
Price \$3.50



128 problem sheets, 8-1/2" x 11", on good quality paper, perforated and bound into a book.

Appropriate for an extensive course of 90-100 lab hours. Content includes: basic orthographic projection, fundamental spatial relationships of elements; applications of descriptive geometry to design and manufacture. There is extensive coverage of intersections and developments, including ruled surfaces; also, axonometric and perspective projection are treated.

DESCRIPTIVE GEOMETRY WORK SHEETS

by J. H. Porsch, S. B. Elrod, R. H. Hammond

Revised edition, 1957.
Price \$3.00

56 problem sheets, 8-1/2" x 11", on good quality paper, perforated and bound into a book.

Designed for a brief course of 35-40 lab hours. Covers basic spatial relationships of points, lines, and planes; includes typical problems on intersection of surfaces. Third angle projection.

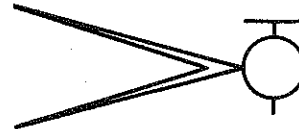

WORKSHEETS FOR INTRODUCTORY GRAPHICS - FORM A

by J. N. Arnold, M. H. Bolds, S. B. Elrod, J. H. Porsch, R. P. Thompson

Published 1958.
Price \$4.00



One hundred sheets, mostly 8-1/2" x 11" with a few 11" x 17", on good quality paper, perforated and bound into a book.

Principal topics are: Lettering, Geometry, Multiview Drawing, Pictorial Drawing, Intersections, Developments, Contoured Surfaces, Functional Design; also a few sheets each on Vectors, Graphical Calculus, Empirical Equations, Representation of Data and Equations.

PROBLEMS IN ENGINEERING DRAWING - ABRIDGED

by W. J. Luzadder, J. N. Arnold, F. H. Thompson

Fourth edition, 1956.
Price \$1.70

A brief set of 40 sheets, 8-1/2" x 11" page size, in an envelope.

Among the topics included: Lettering, Use of Instruments, Geometrical Constructions, Freehand Sketching, Multiview Drawing, Auxiliary Views, Sections, Detail Drawing.

Appropriate for a brief course, particularly for some groups of technical institute students who are not pointing toward drafting or design.

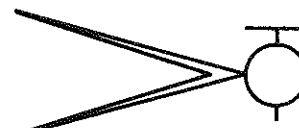

Examination copies of any of these are available upon request.

BALT PUBLISHERS

308 STATE STREET

WEST LAFAYETTE, INDIANA.

Editorial

"THE NEW BREED"

The trend in engineering education today is toward specialization with emphasis on teamwork. Perhaps specialization is a logical direction because of the flood of new knowledge which has suddenly become important. No one individual, however, can be expected to acquire all knowledge related to any given specialized field of study.

The engineer, scientist, technician and craftsman must all clearly understand each other. Engineering education must provide students with the knowledge, attitudes, and skills which will prepare students for solving the unknown variety of problems which they will surely face tomorrow as practicing engineers.

Effective teamwork requires complete communication. Collective efficiency also draws attention to new operational procedures and professional ethics. We must have proper programs of education for both our "plumbers" and our "philosophers" or neither our pipes nor our ideas will hold water. We must encourage individual achievement, but we must also have adequate cooperation between units of operation. The final proof of proper education is successful team performance.

The Engineering Graphics Division is confronted by two pertinent questions. (1) How are the requirements of teamwork and specialization going to affect engineering graphics courses? And (2), how can we prepare, in the time allotted, workers in all areas of engineering with adequate knowledge and ability to apply the principles of graphical communication. Both questions are critical.

There are definite dangers of manpower obsolescence through premature specialization. Unless we have failed grossly in our educational obligation in years past, a substantial portion of the subject coverage in the present curriculum is absolutely essential and cannot be discarded. We must retain that portion which presents the basic principles most effectively. Extreme specialization without the acquisition of basic principles of his profession may make the engineer or scientist immediately useful, but it may hasten the obsolescence of his learning.

Economical design is the key to successful engineering. The old handbook and slide rule is no longer adequate. Engineering graphics is a logical tool for combining numerous considerations which normally confront the engineer while he is in the process of making critical decisions and definitely should contribute to his individual progress. It helps him to assimilate the whole in terms of units contained therein.

Likewise, we cannot bury ourselves in old methods. We must keep abreast of engineering needs and adjust our instructional efforts to cope with the ever-increasing services which may be required of our students.

Engineering graphics can be a science which furnishes a means of analysis, concept definition, solution, and communication only if we make it so. The application and implementation is up to us.

Communication among members of the Engineering Graphics Division of ASEE is necessary. To assist all members of the Division is one of the major services which the editorial staff of The Journal of Engineering Graphics hopes to perform. Will you assist us by sending news about the new and different? Perhaps you have a problem in graphics which needs to be solved. One of your colleagues may need your information or has an answer which he could pass along.



Earl D. Black, Editor

SUBSCRIBE TO

JOURNAL OF ENGINEERING GRAPHICS

PUBLISHED THREE TIMES A YEAR -

WINTER, SPRING & FALL ISSUES -

ANNUAL SUBSCRIPTION \$2.00

SINGLE COPY75

Write: William B. Rogers
Department of E.S. & G.S.
U. S. M. A.
West Point, New York



THE DIVISION OF ENGINEERING GRAPHICS



BOARD OF DIRECTORS 1964-1965

- R. H. Hammond, Chairman
U. S. Military Academy
- J. H. Porsch, Vice-Chairman
Purdue University
- M. F. Blade, Secretary
The Cooper Union
- B. L. Wellman, Sr. Council
Worcester Polytechnic Institute
- E. G. Pare', Treasurer
Washington State University
- E. R. Weidhaas, Director
Pennsylvania State University
- J. N. Arnold, Director
Purdue University
- R. R. Worsencroft, Director
University of Wisconsin
- M. W. Almfeldt, Director
Iowa State University
- A. S. Palmerlee, Division Editor
University of Kansas
- E. D. Black, JEG Editor
General Motors Institute
- M. G. Mochel, Advertising Manager
Clarkson College of Technology
- W. B. Rogers, Circulation & Treasurer
U. S. Military Academy

Industry Supports Engineering Graphics

C. Ernesto S. Lindgren, an authority on four-dimensional descriptive geometry, has been appointed Visiting Research Engineer to the Department of Graphics and Engineering Drawing at Princeton University.

Mr. Lindgren, a civil engineer with the United States Steel Corporation, will do research and writing and give special lectures and seminars in his field. The Department of Engineering Graphics is part of Princeton's School of Engineering and Applied Science.

Professor Steve M. Slaby, chairman of the department, said the appointment represented a "milestone." "It is the first time, to my knowledge, that a major industrial corporation has granted substantial support to theoretical work in Four-Dimensional Descriptive Geometry," he said.

Mr. Lindgren, who is 31 years old, was born in Rio de Janeiro, Brazil. In 1956 he received the degree of Civil Engineer from the National School of Engineering of the University of Brazil. He taught at the University Institute (which is a private institution) from 1953 to 1957 and at the Polytechnic Institute (supported by the University of Brazil) during 1953. In 1954 he attended the University's National School of Fine Arts for advanced study in descriptive geometry. It was during this period that he presented the first draft of a paper in which he showed the development of Four-Dimensional Descriptive Geometry.

Mr. Lindgren came to the U.S.A. from Brazil in February 1958 to join the Design Engineering Office of the United States Steel Corporation in Pittsburgh, Pennsylvania.

Last June he received the Descriptive Geometry Award of the Engineering Graphics Division of the American Society for Engineering Education. The award was for an article, "Descriptive Geometry of Four-Dimensions," published in the Fall 1963 issue of the Journal of Engineering Graphics.



STANDING COMMITTEES - 1964-1965

Aims, Scope and Status of Engineering Graphics

- J. S. Dobrovoly, Chairman
University of Illinois
- C. P. Buck
Syracuse University
- A. F. Devaney
Amarillo College
- J. J. Devine
Northeastern University
- P. H. Hill
Tufts University
- H. B. Howe
Rensselaer Polytechnic Institute
- H. T. Jenkins
University of Michigan
- A. S. Levins
University of California (Berkeley)



Aims, Scope and Status
(continued)

- A. P. McDonald
Rice University
- E. V. Mochel
University of Virginia
- F. Oppenheimer
Grammercy Guild Group, Inc.
- E. G. Shiels
University of Wisconsin
- G. K. Stegman
State University of Iowa

Educational Relations

- R. S. Lang, Chairman
Northeastern University
- S. C. Allen
Michigan College of Science & Technology
- J. R. Barylski
New Bedford Institute of Technology
- E. C. Bergmann
Michigan State University
- A. L. Bigelow
Princeton University
- L. C. Christiansen
Missouri School of Mines & Metallurgy
- R. J. Cooper
Columbia University
- A. S. Gaskell
University of Missouri
- K. E. Kroner
University of Massachusetts
- C. P. Marion
University of Miami (Florida)
- M. G. Mochel
Clarkson College of Technology
- S. P. Owen
Rutgers University
- G. Rook
Northeastern University
- H. D. Walraven
University of Illinois
- I. Wladaver
New York University
- W. A. Wockenfluss
University of Maryland
- E. C. Zulauf
University of Detroit

Industrial Relations

- K. E. Botkin, Chairman
Purdue University
- F. K. Brown
Northeastern University
- J. R. Burnett
Michigan State University
- J. D. Collins
University of Washington
- S. G. Hall
University of Illinois
- M. E. Hamilton
New Mexico State University
- T. R. Long
West Virginia University
- A. E. Messenheimer
Kansas State University
- R. W. Parkinson
Ohio State University
- R. W. Rynolds
California State Polytechnic College
- R. D. Springer
University of Minnesota
- F. M. Woodworth
University of Detroit

Teaching Techniques

- H. P. Ackert, Chairman
University of Notre Dame
- R. A. Campbell
Pennsylvania State University
- C. W. Chance
University of Texas
- R. I. Hang
Ohio State University
- L. O. Johnson
New York University
- C. W. Keith
Kent State University
- H. G. Kinner
Rensselaer Polytechnic Institute
- E. A. Knoblock
University of Wisconsin (Milwaukee)
- K. E. Kroner
University of Massachusetts
- R. D. Mitchell
Auburn University
- W. B. Rogers
United States Military Academy
- C. G. Sanders
Iowa State University
- E. C. Schamehorn
West Virginia Institute of Technology

Display of Instruments, Materials, and
Reproduction Processes

- C. Z. Westfall, Chairman
University of Maine
- K. E. Botkin
Purdue University
- L. N. Gulick
University of Pennsylvania
- P. O. Potts
University of Michigan
- G. P. Weidmann
University of Massachusetts

Drawing Exhibit

- A. V. Hillery, Chairman
Ohio Northern University
- H. P. Nelson
Wayne State University
- A. C. Risser
University of Wichita
- C. Z. Westfall
University of Maine

Bibliography

- T. Dolan, Chairman
Illinois Institute of Technology
- G. S. Dobbins
University of Colorado
- W. Felbarth
University of Detroit
- A. S. Little
Auburn University
- R. H. Siegfried
Cornell University

Descriptive Geometry Award

- I. L. Hill, Chairman
Illinois Institute of Technology
- J. M. Coke
Colorado School of Mines
- A. L. Hoag
University of Washington
- A. S. Palmerlee
University of Kansas
- S. M. Slaby
Princeton University

Special Awards

- E. M. Griswold, Chairman
The Cooper Union
- M. McNeary
University of Maine
- B. L. Wellman
Worcester Polytechnic Institute

Nominations

- I. Wladaver, Chairman
New York University
- E. M. Griswold
The Cooper Union
- L. O. Johnson
New York University
- M. McNeary
University of Maine
- A. C. Risser
University of Wichita

Elections

- J. H. Porsch, Chairman
Purdue University
- R. L. Isbell
Valparaiso University
- C. J. Rogers
Purdue University

GOALS OF ENGINEERING EDUCATION STUDY

- J. S. Dobrovolny, Chairman
University of Illinois
- C. J. Baer
University of Kansas
- C. P. Buck
Syracuse University
- E. M. Griswold
Cooper Union
- R. H. Hammond
U. S. Military Academy
- P. H. Hill
Tufts University
- E. W. Jacunski
University of Florida
- E. V. Mochel
University of Virginia
- S. M. Slaby
Princeton University
- F. H. Smith
University of Michigan
- E. R. Weidhaas
Penn State University

Policy

- E. M. Griswold, Chairman
The Cooper Union
- F. A. Heacock
Princeton University
- I. L. Hill
Illinois Institute of Technology
- M. McNeary
University of Maine
- B. L. Wellman
Worcester Polytechnic Institute

Inter-Disciplinary Relations

- P. M. Reinhard, Co-Chairman
University of Detroit
- S. M. Slaby, Co-Chairman
Princeton University
- C. J. Baer
University of Kansas
- J. R. Burnett
Michigan State University
- S. A. Coons
Massachusetts Institute of Technology
- W. H. Eubanks
Mississippi State University
- L. G. Palmer
University of Minnesota
- E. R. Weidhaas
Pennsylvania State University

Future Development of Engineering Graphics

- C. P. Buck, Chairman
Syracuse University
- E. D. Black
General Motors Institute
- M. F. Blade
The Cooper Union
- S. A. Coons
Massachusetts Institute of Technology
- J. S. Dobrovolny
University of Illinois
- J. Gerardi
University of Detroit
- R. Lewis
Duke University
- E. W. Jacunski
University of Florida
- P. M. Reinhard
University of Detroit
- J. S. Rising
Iowa State University
- W. E. Street
Texas A & M University
- R. W. Waymack
Modesto Junior College
- E. R. Weidhaas
Pennsylvania State University

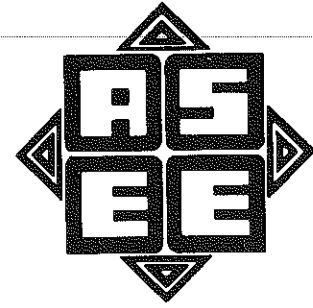

SLATE OF CANDIDATES FOR
DIVISION OF GRAPHICS 1965-1966

This slate is subject to revisions, especially additions by petition. Therefore, it cannot be considered as final for the making up of the ballots until after January 31, 1965. This list is published so that the members of the Division can take action if they wish to petition for other candidates.

Vice Chairman:

Mary F. Blade, The Cooper Union
Carson P. Buck, Syracuse University

Secretary:

Albers S. Palmerlee, University of Kansas
William B. Rogers, United States Military Academy

Director and Treasurer, Executive Board:

Charles J. Baer, University of Kansas
Percy H. Hill, Tufts University

Circulation Manager and Treasurer of the
Journal of Engineering Graphics:

James H. Earle, Texas A & M University
Forrest M. Woodworth, University of Detroit

NOMINATIONS COMMITTEE:

Irwin Wladaver, Chairman
E. M. Griswold
L. O. Johnson
Matthew McNeary
A. C. Risser

Officers' Page

A MESSAGE FROM YOUR CHAIRMAN

It is a great honor to have been selected by you to be the Division's Chairman for this year. The key words here are "by you". For this is, and must be, your Division. The Chairman should be a coordinator and expeditor of events and should reflect the total will of the group when he speaks or acts in the name of the Division.

The members of the Division are usually quite vocal when conversing in the hallways, eating places and in the back of the room during meetings. However, these are informal discussions and your Chairman and Executive Committee cannot possibly be present at all such sessions and hear all of your views. And it is difficult to remember completely all that is heard at these gatherings. So if your Chairman and Executive Committee are to reflect your desires and feelings, you must communicate with them. Communication is supposed to be a specialty of our particular profession. Yet it seems to break down in this instance. So, when you feel that a certain topic should be discussed, write to the Chairman or a member of the Executive Committee. If you didn't like a program, write so that that type of program can be avoided in the future. Of course this does not mean that each and every suggestion or complaint can be satisfied. As in any democratic organization, the will of the majority will be the deciding factor. Each communication will be considered; however, if there is little or no communication, the will of the majority cannot be known.

Another way that the members of the Division can influence the future course of activities is to serve

on the various committees. Each year the question is asked, "How do I get on a committee?" The answer is again: communication. The committees for the 1964-1965 year are set up according to your Chairman's best information. However, the composition of each committee should be continually changing with new members added each year and older members dropping out. This is the best way to keep all committees fresh, vital, and up-to-date. Yet how can this be accomplished without knowing your desires? Your Vice Chairman will be arranging the committees for the year 1965-1966. Let him know if you want to serve on a particular committee or if you would like to be moved from one committee to another. Of course, serving on a committee involves a certain responsibility on the part of the member. He should attend as many meetings as possible, with attendance at the Annual Meeting as a minimum. There is always the possibility that this cannot be accomplished each year, but it should be the goal.

Finally, the program for the 1965 Annual Meeting is still in a fluid state. If you have any ideas about programs or topics, communicate. Your Chairman would welcome any and all suggestions. In this way only can he be "Your Chairman."

Bob Hammond

Chairman, Graphics Division

DESCRIPTIVE GEOMETRY in the SPACE AGE

by Thaddeus Pozniak, Ph.D.

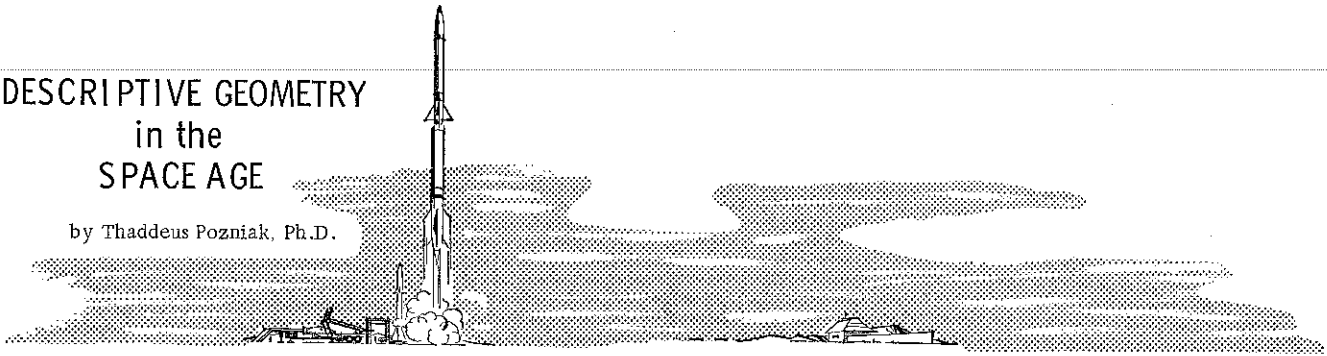

As a teacher of mathematics and in particular of descriptive geometry I would like to take the opportunity to make a few remarks concerning the position of descriptive geometry in mathematics curricula.

My experience in this field comes from having taught and supervised in European schools prior to World War Two, in military schools during the second World War, and from teaching descriptive geometry on the college level in the United States for the past seven years. I have also published two successful research papers in this field within the last two years.

I think some fruitful discussion may result from my remarks concerning descriptive geometry since the comments I am going to make are closely related to ideas expressed in the previous issue of The Journal of Engineering Graphics, Vol. 28, No. 2, 1964--Series No. 83.

1. "Creative thought is, after all, the aim of all engineering and scientific endeavors and we should nurture it in our educational programs" (page 3, "Editorial," by Mary Blade, Editor);
2. "...a university should have the foresight to anticipate the dictates of change..." (page 27, "Engineering Education & Engineering Graphics," by Irvin Wladaver);
3. "Descriptive Geometry is still alive, but...it can be beaten to death--with a T-square!" (page 18, "Descriptive Geometry--Some Reflections...", by William B. Rogers).

As a teacher of mathematics may I be excused for introducing my remarks with a few comments concerning mathematics.

Much has been done and is being done today to modernize the teaching of mathematics in American schools at the elementary, high school and college levels.

A good deal of obsolete material in geometry, trigonometry, solid geometry, and other areas of mathematics is being eliminated, and more of probability, statistics, logic, linear algebra, and the like is being introduced.

Engineering, business, psychology, education, biology, sociology, and many other fields in addition to physics and chemistry, are now using more and more mathematics, thus bringing about the necessity of dropping the obsolete parts of classical mathematics and introducing new ones as mentioned above.

As a result of this basically justifiable trend of changes in school curricula, geometry has already suffered drastic changes, and will suffer even more. However, such changes can be overdone and in many cases may even be dangerous.

There is no doubt that we are all now in the era of space. This fact calls for developing in the human mind the ability of spatial thinking more intensively and with wider scope than was the case in the recent past.

The reduction of geometry--though necessary--should not be limited to the removal of obsolete material; rather an effort should be made toward the development of a new kind of geometry, suitable to the needs of the age of space.

A third power of "spatial visualization"--combined with the ability of "abstract thinking" and "logical reasoning"--is necessary in modern mathematics, and consequently in modern geometry.

It is a well known fact that a student's intellectual power of "spatial visualization" is most efficiently developed by the science of descriptive geometry. It is the science of descriptive geometry that performs that task best of all other kinds of geometry--projective, solid analytic geometry, and others. On this point mathematicians, engineers and educators are in agreement.

The science of Descriptive Geometry needs to be deepened and broadened by new laws, and new constructions to make it richer, more mathematical, and a more adequate science of space.

A great deal of work has been recently done in this direction¹, and still more work of this kind should be encouraged--especially on the part of colleges and universities.²

Descriptive Geometry is really "alive," but it must become, through creative thought, a mighty science of the era of space.

It is an undeniable truth that descriptive geometry is both an art and a science. It is also true that it can be appropriately adjusted to the educational needs of high school and college students in both the liberal arts and engineering programs.

The goal for descriptive geometry in this era of space is not just to survive at engineering colleges and technical institutes, but to become a new science, indispensable in all American schools, from the elementary grades through the university.

A major objective in contemporary education should be that courses in descriptive geometry be given the same recognition as other courses in mathematics offered in the curriculum. This is also the feeling of many teachers of geometry.

It might, therefore, be worthwhile for those responsible for curriculum development to give serious consideration to this problem.

Finally, there are two peculiar aspects of this whole problem that should be clarified.

1. Most mathematicians do not know descriptive geometry. Nevertheless, they are the individuals responsible for the modernization of mathematics courses including geometry.

The result, as may be expected, is that descriptive geometry is actually disregarded and deprived of its rightful place in mathematics curricula.

2. Most of the engineers who know descriptive geometry are primarily interested in its applications to practical purposes. Indicative of this are the descriptive geometry textbooks. Their titles frequently include "Engineering" descriptive geometry; "Technical" descriptive geometry; "Practical" descriptive geometry; "Applied" descriptive geometry, and the like. All of them underscore the aspect of the applica-

bility of the science of descriptive geometry, but not the theory of this discipline. Yet the fact is that only from a richer and deeper theory of the science can more numerous and more adequate applications be made.

The above two conditions do not work in favor of the restoration of the science of descriptive geometry to its appropriate role in the present day school curriculum.

The question arises then, "Is this situation really hopeless?" The answer is, No! For the following reasons;

1. The age of space will not permit the most efficient spatial geometry--which descriptive geometry undoubtedly is--to vanish from the horizon of American modern education. Sooner or later its role in education will be restored and widely recognized.

2. A great deal of research has been and is being done recently in the field of descriptive geometry. New laws and new constructions are being found. The science of descriptive geometry is becoming richer in its theory and in its applications, and at the same time it is becoming more easily adaptable to different school curricula.

3. A new manpower of educators, with adequate mastery of both mathematics and descriptive geometry--though not too numerous, but dedicated to the task--is available, and should be invited to work.

These men will fill in the gap that exists between the pure mathematicians and the pure engineers, thus enabling the development of a complete and competent body of experts for a sound modernization of the school curricula, and the appropriate role of the science of descriptive geometry in contemporary education.

1. Prof. Borecky of the University of Toronto-- Research Projects in Descriptive Geometry, 1963.

2. S. Coons of M.I.T.--"The Future Course of Engineering Graphics"- 1962.

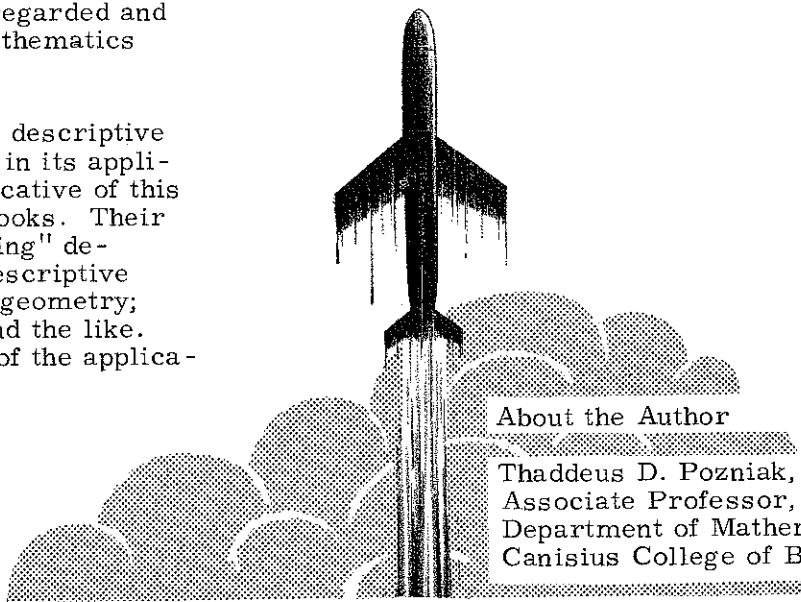

About the Author

Thaddeus D. Pozniak, Ph.D.
Associate Professor,
Department of Mathematics,
Canisius College of Buffalo, N. Y.

THE CHRISTIAN APPROACH TO

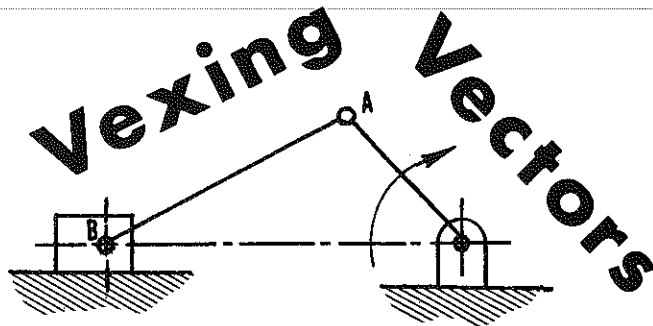

By
MARSHALL J. CHRISTIAN
Assistant Professor of Mechanical Engineering
General Motors Institute

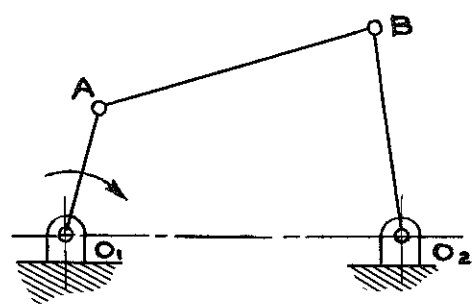

Have you ever started out on a trip with your destination fixed firmly in your mind, but a bit unsure about the route you will follow? You come to a fork in the road--and both ways look equally inviting--so you turn right instead of left (or vice versa) and you find out some time later that you are headed in the wrong direction.

The engineering student often finds himself in this same situation when making a graphical vector analysis of a mechanism for linear velocities and linear accelerations.

The big difficulty lies in the writing of relative velocity and relative acceleration vector equations. The relative velocity or relative acceleration vector that we are looking for is that one which by definition is the motion of a point on a member as it moves about another point on the same member as a center. Therefore the term relative, or as sometimes referred to, as motion of one point with respect to another.

The relative velocity vector equation as applied to this situation would be as follows:

$$V_B = V_A + V_{B/A}$$

the V_B and V_A being absolute values because they are said to have motion relative to fixed points whereas the $V_{B/A}$ is referred to as the relative velocity because its motion or velocity is taken relative to a point which is not fixed as in the cases of V_B and V_A . The $V_{B/A}$ means the velocity of point B as it turns about point A as a center.

The difficulty in writing this type of equation lies in the arrangement of the relative term, should it be written $V_{B/A}$ or $V_{A/B}$? The wrong choice here can change the whole picture in the results because the values would be reversed in directions and greatly detract from any values which would be found from the use of values having the wrong sense.

I have worked with this problem with students and have tried various ways to put the relative vector equation in a form that would set with them and I believe the one that I have now been using for the last few years has caught their fancy and is producing better equation and results without the hit or miss tactics that were so often used.

I refer to the equation as the "yuk yuk" equation and it works like this. As you remember the relative velocity vector equation in its standard form is $V_B = V_A + V_{B/A}$. Let us call the first term V_B the V_u , velocity of the unknown, and the second term V_A , V_k the velocity of the known because this is the velocity which you will have to know to start. The third term, the relative, becomes $V_{u/k}$ the velocity of the unknown relative to or with respect to the known. The equation now in a standard form and using subscripts which mean something more to the user than letters or points on a member becomes

$$V_u = V_k + V_{u/k}$$

Freely reading the subscripts as "yuk yuk" I find the students remember the form easily and can write it with much less confusion, which aids them in solving problems readily and correctly.

The "yuk yuk" form can be used equally well on the linear acceleration vector equations -- try it!

And when you have a vector equation problem, don't fret and stew -- Just sit back and yuk! yuk! it through.





"I feel that this is an excellent book and I am planning to adopt it for use . . . as soon as it is off the press."*

BASIC DRAWING FOR ENGINEERING TECHNOLOGY

By **RANDOLPH P. HOELSCHER**, *recently of the Department of General Engineering, University of Illinois;*
CLIFFORD H. SPRINGER, *recently of the Department of General Engineering, University of Illinois;*
and **JERRY S. DOBROVOLNY**, *Head of the Department of General Engineering, University of Illinois.*

This lavishly illustrated book is written specifically for the beginning technical student and draftsman. The authors, working on the assumption that one picture is worth a thousand words, explain all the more complicated theories and problems by the use of abundant illustrations. Each author has many years of experience in teaching the subject: They know exactly what is needed in a text of this kind. For example, the problems at the end of each chapter are of graded difficulty, suitable for students at varying levels. And, to insure the proper scope for all classes, a wider selection of problems is presented in a special chapter that includes more than 1000 items. These problems include word problems, completion problems, and straight drawing problems.

CONTENTS

PART I BASIC DRAWING TECHNIQUE

Lettering • Techniques in the use of Instruments • Geometry of Graphical Constructions • Sketching Technique

PART II SHAPE DESCRIPTION

Orthographic Projection • Axonometric Projection and Drawing • Oblique Projection • Perspective Projection • Section Views • Auxiliary Views • Intersections and Developments

PART III SIZE DESCRIPTION

Mechanical Fasteners and Welding • Basic Dimensioning • Production Dimensioning

PART IV GRAPHICAL COMMUNICATION

Charts and Diagrams • Drawing Control and Reproduction • Supplemental Problems • Appendix

Special Features . . .

- Direct and easily understood wording and standard terminology are used throughout the book
- Text and illustrations are consistently interrelated — wherever possible, step by step construction is shown
- Isometric, Dimetric, and Trimetric projection, as well as oblique drawing and perspective, are presented so that any student can readily apply them to practical problems
- Practical methods and devices are shown to speed up drawing work
- The two chapters on dimensioning include the latest standards of true position dimensioning and geometrical form tolerances
- The chapter on modern drawing reproductions stresses methods used in industry
- Complete instructions for setting up a drawing control system in an industrial plant using microfilm aperture cards are given
- Decimal dimensioning is emphasized
- A complete appendix with tables from ASA Standards is included

1964. 396 pages. \$6.95.

**from a pre-publication review*

Send for on-approval copies

JOHN WILEY & SONS, Inc.

605 Third Avenue

New York, N. Y., 10016



... with chalkboard adapter

Makes your instruction job easier. Develops better drafting students in less time. Modern teaching methods demand good graphic presentation—the VEMCO V-TRACK with Chalkboard Adapter gives you just that! Specify VEMCO V-TRACK.

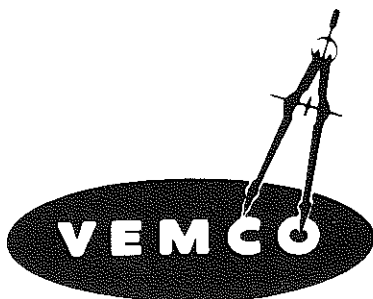

V. & E. MANUFACTURING CO.
766 So. Fair Oaks Ave., Pasadena, Calif.

PERSPECTIVE

..... to the New Instructor

H. C. Spencer
5412 Lake Charles Drive
Waco, Texas

I was surprised when your editor named me to be the lead-off man in the "Perspective" column. However, I suppose I qualify because I taught for 36 years, and am now retired. I retired in 1962 because of a slight difficulty with rheumatoid arthritis. I now do some writing and other things I wanted to do while I was teaching.

As school starts again, I think of the young instructor and his new responsibilities. If I were still running a department and hiring new teachers, I would have something like the following to say to them.

There is a certain technique which the teacher should follow in helping students. Of course, each teacher will develop his own methods which he has found to be effective.. In general, he should not simply answer a question in order to get rid of the student as quickly as possible. It is a good idea to follow Socrates' method, which was to question the student in such a way that the student answers his own question.

The teacher must have the right attitude toward the student when asked for help. He should not say crossly, "Look it up in the book" or "We covered that last week; where were you?" The teacher should not assume that the student is asking the question just to be irritating. He should assume that the student really wants to learn, even when it seems otherwise. Of course, some students will ask too many questions, but in every case they should receive a courteous reply, even if the reply is in the form of another question. Never turn a student away with a refusal to help. Encourage him; never discourage.

During the laboratory, continually move about the room, keeping up with what the students are doing. Do not allow a student to waste an hour working on the wrong track when a tip from the teacher would set him right. By no means should the teacher bring his office work or private business into the laboratory so that he can work while the students are drawing - and, of course, making mistakes. The laboratory period should be used for teaching, and for nothing else.

Some teachers have the habit of continually leaving the laboratory, sometimes for extended periods of time. Such classes are apt to be disorderly, and certainly the learning situation is very bad. I have noticed that the classes of some teachers are always quiet and businesslike, while others are in a continual uproar. Students should not be allowed to roam about the room visiting with other students. Neither should they be allowed to loiter in the halls "for a smoke." The order in the classroom is a direct result of the behavior of the teacher. A teacher who cannot or will not conduct his classes in a quiet business-like manner should be fired.

Never "bawl out" a student, especially in the presence of others, as in a class or laboratory. If you have anything unpleasant to say to a student, say it quietly so others cannot hear - if possible, in the privacy of your own office.

A teacher should be friendly with students, but should not try to act like a student himself. Teaching is not a popularity contest. In general, a teacher should not tell jokes in class, especially questionable ones. The teacher should use good English at all times.

The teacher should be available. He shouldn't always be somewhere else when he is needed by the department head or by the students, especially the latter. As a rule, his door should be open, and he should be glad to take time out to help any student. I have known some teachers who always came bustling in just before class time and then rushed out just as soon as the class was over.

Never take the attitude that the student is "dumb," even when that is obviously the case. Remember, we are all "dumb," only about different things. Be careful with the tone of your voice, and your choice of words, not to convey the idea to the student that you do not respect him. Give every student the respect you expect from him.

In lecture classes, conduct yourself with dignity and poise. Prepare your lesson well in advance. Do not talk too loudly or too fast, or when facing the blackboard. Use sketches freely, and prepare in advance the sketches you intend to put on the board. Your notes should contain not only an outline of what you plan to cover, but sketches you intend to use, as well.

It is always better to "discuss" rather than lecture in the formal manner. The formal lecture is the poorest method of teaching ever invented. Bring the members of the class into the discussion. Ask them questions, and let them ask you questions. Student participation is the key.

continued on page 22

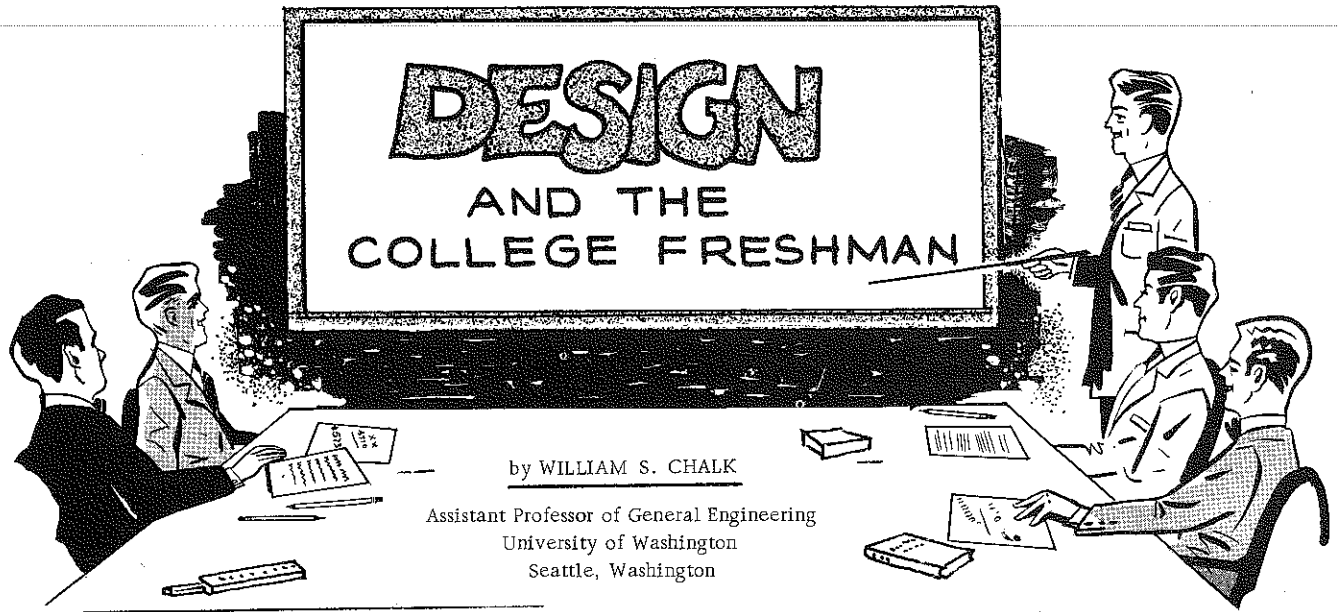

by WILLIAM S. CHALK

Assistant Professor of General Engineering
University of Washington
Seattle, Washington

Numerous articles have been written recommending that design and creative thinking be incorporated in freshmen engineering courses, particularly engineering graphics sections. Only a few authors have outlined in detail how they have successfully accomplished these innovations. The following paragraphs contain a discussion in detail of how an introduction to systems analysis, design and creative thinking were introduced in a freshmen engineering graphics course. The material in this article can be incorporated easily in any graphics course employing the usual engineering graphics texts.

The course to be discussed met 20 times for two hours each session. There were approximately two to three hours of homework assigned each week for the two-hour credit course. The students' background in graphics consisted of one quarter's experience in engineering fundamentals such as sketching, orthographic projection, scales and dimensioning. There were nineteen students enrolled in the course.

Beginning engineering students lack confidence in expressing their original ideas. A few reasons for this diffidence are the pressure to conform in most classrooms, the fear of ridicule by their instructors and/or classmates and the absence of guidance by their instructors for developing their potential for being creative. One type of assignment to encourage students to use and develop their creative potential was given as a sketching exercise. As a half-hour assignment, each man in the class was asked to sketch a design of a nameplate with his name on it. The nameplate would be for his desk which he would have were he a successful engineer in the field of his choice. Three-fourths of the students produced nameplates which were triangular in cross section, and the surface for

their name was at either 45° or 60° from the horizontal. During the next half-hour it was emphasized that without their realizing it, they were conforming to what has been done in the past. The succeeding assignment was twofold. The first half-hour was to be an imagination-triggering exercise. The students were encouraged to sketch all the ideas for a nameplate which came to their minds, no matter how ridiculous they seemed at the time. In the half-hour following, they were to select and sketch one of these. The second set of results were encouraging. Most of the students employed their imagination and produced some creditable designs. For example, a potential civil engineer drew a miniature bridge with his name on it; an electrical engineer had his name suspended in a magnetic field; an aeronautical engineer had a modernistic sculpture to support his name. (After the session a few students commented that they seldom had had encouragement to use their imagination in technical courses, particularly in shop and engineering drawing courses.) These sketching exercises were followed by a general discussion of creative thinking, and design methodology.

The students were told that creative thinking can be divided into three general levels which they will be expected to attain as engineering problem solvers and designers. Level one is experienced by anyone who accomplishes something new or different relative to himself. For example, an individual who formulates a new combination of fundamental laws, rules, principles, mechanisms, circuits, processes, etc., to solve a problem is being creative. Problems of this type are usually assigned to most engineering undergraduates in college and they are the one answer type of problems customarily employed to teach principles, laws, etc. The

continued on page 16

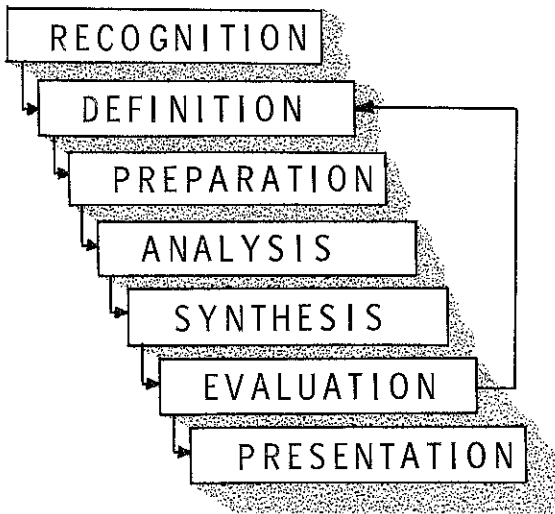

Figure 1

students experience level one of creative thinking to solve hundreds of these. Level two includes solving problems with more than one satisfactory answer depending on the original assumptions, judgments and decisions of the student. Often, these are the starred problems in a set of exercises at the end of a chapter. As an example of level two problems in the course being discussed, the students were given a plan view of an object and were asked to draw several valid elevation views off the same folding line. As another example, the students were referred to a set of drawings of a hand-operated, bench mounted press. The problem was to determine the force exerted at the end of a ram which was driven by a rack and pinion gear mechanism. A ten-inch long lever was attached to a pinion-gear shaft and was to be hand operated by an average worker during an eight-hour day. The students had to assume a reasonable pulling force exerted by an average laborer, study the drawings to determine the operation of the press, and then utilize a simple moment equation to calculate the resulting force at the ram of the press. Nineteen different answers were given, however, all were within an acceptable range. Level three of creative thinking was called design. The majority of the lecture time was devoted to design methodology and further aspects of the creative process in solving design problems.

Design methodology was introduced to these freshmen by means of a simple flow chart as shown in Figure 1. The terms were defined and discussed as follows. **RECOGNITION** indicates that a design problem exists. In the classroom the students are given the design problem. In industry the problems evolve from numerous sources such as the customer, the industry, the perceptiveness of the engineer to the needs of society, etc. **DEFINITION** is the process of dividing the problem into subdivisions for efficient handling. **PREPARATION** entails the collecting of all pertinent facts, theories, laws, principles and rules from the designer's experience, education, and research. **ANALYSIS** is the sorting, studying and culling of the data

collected during the preparation phase. **SYNTHESIS** is the process of formulating possible solutions to the problem based on the collected data. It is the most challenging, creative and difficult step in the design process. Sketching ability, layout drawing techniques, and systematic recording of ideas are helpful tools and habits to develop for success in this phase. The ability to formulate analytical and/or fabricate physical models of the problem is a valuable asset at this time also. **EVALUATION AND FURTHER ANALYSIS** of the possible solutions are next. The design problem may be redefined and reevaluated several times as the flow chart indicates. Ultimately a decision is made to select one of the solutions. **PRESENTATION** can take the form of a report, a set of drawings, a collection of sketches, or combinations of all of these, depending on who is to be the recipient of the information. As a conclusion to this part of the design methodology discussion it was shown how the courses in a student's curricula (including humanities) would prepare him for solving engineering design and/or research problems. For example, most of his course work would help him in the preparation step. Mathematics would help him in the analysis phase. Graphics and report writing would help him present his ideas. Humanities would enhance his potential for recognizing problems of the world such as the problem of providing water and food for future generations. Having this overall framework of design for relating his course work tends to give an engineering student more of an appreciation for the courses he takes and an incentive to learn on his own.

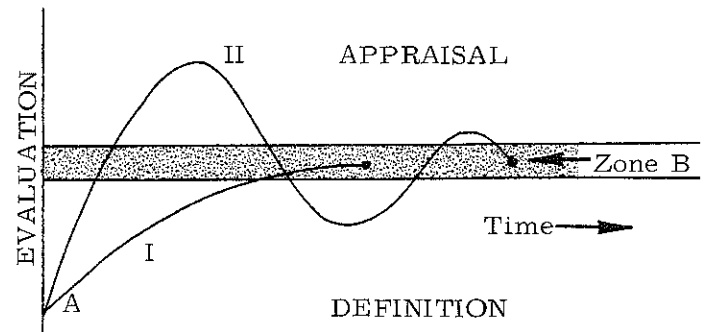

Figure 2

To continue the discussion of design a graphic illustration was presented as shown in Figure 2. After recognizing that a design problem exists the designer is at point A on the graph. He desires to reach the solution zone B as soon as possible. The area below the solution zone is called the definition zone. The area above is called the appraisal zone. The designer begins at point A (conception) and in striving to terminate at the zone B he may follow several different paths; two are shown. Path I illustrates the evolution of a simple straightforward design; that is, the engineer performs the design steps only once and terminates with a satisfactory solution. Path II shows the iterative nature of a more complex design problem. The design steps are repeated several times before a solution is

evolved. Several valid solutions are possible, hence a zone is shown rather than a line at point B.

Following the introduction to design methodology the students were given an introduction to some terms describing a further creative process in design. Four terms were used. ACCUMULATION is the act of storing all the pertinent information related to a design problem in the designer's conscious mind. Usually the accumulation phase requires a great deal of effort and active involvement with the problem. INCUBATION describes the second phase. In effect it is believed that the subconscious mind acts on the stored information until (after days, weeks, months or years) a solution(s) is conceived. ILLUMINATION is the startling realization in the conscious mind that there is a solution. An example of this phenomena which most students have experienced is the agonizing illumination of a solution to a problem on a mid-term or final examination after the examination is over. This may occur after several hours or days have passed. VERIFICATION is the analysis and refinement of the solution. To show graphically where the subconscious creative process merges with the design process the plot of Figure 3 was presented.

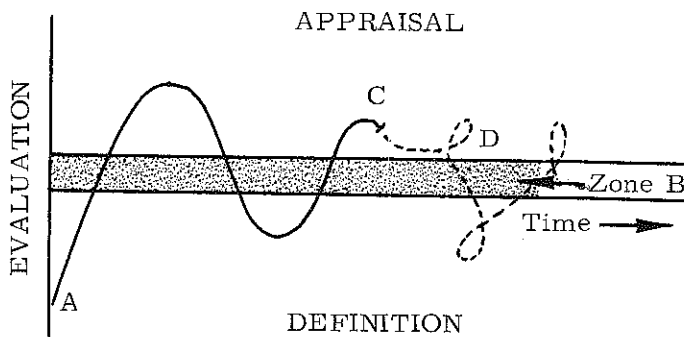

Figure 3

The accumulation step in the creative process would be repeated by the path between points A and C which can be recognized as the iterative design process. At C the designer reaches an impasse in his conscious effort to solve the problem so he temporarily shelve the problem and attends to other matters. Subsequently his subconscious mind begins to play the dominant role in solving the problem and hopefully at D a solution is uncovered.

Several students admitted that they had experienced both types of thinking processes (design and creative) in solving their personal problems. One of the reasons for outlining in detail their natural thinking processes was to help them understand themselves and thus to give them a feeling of confidence for systematically and efficiently attacking more complex problems in engineering design and/or research.

A number of assignments requiring the students to use their imagination were given next. One of them was to design an efficient workplace for assembling the parts of a tool vice (typical of the assemblies given in most graphics texts) by an average male employe. The dimensions of an average 5'8" man were given to the students. His average reach and optimum working areas were presented (these may be obtained from books or references on human engineering). Several principles of motion economy were discussed such as (1) use gravity to help the worker, (2) put the parts to be assembled within easy reach of the employe and (3) have both hands employed simultaneously. The students were required to; (1) sketch their ideas of a workspace; (2) prepare layout drawings of their workspace design showing the position of the average male employe in relation to the locations of the bins of parts, the working space, the assembly jigs, the powered tools for assembly, etc.; and (3) include sufficient information on the layout drawing so a draftsman could detail the workspace for fabrication. The freshmen students readily grasped these ideas of human engineering and motion economy and used them effectively in designing a workspace. Figure 4 is an example of one student's layout drawing of his design of an efficient workspace.

The sketch shown is a copy of a student's layout of his idea of an efficient workplace. Notes and dimensions have been omitted.

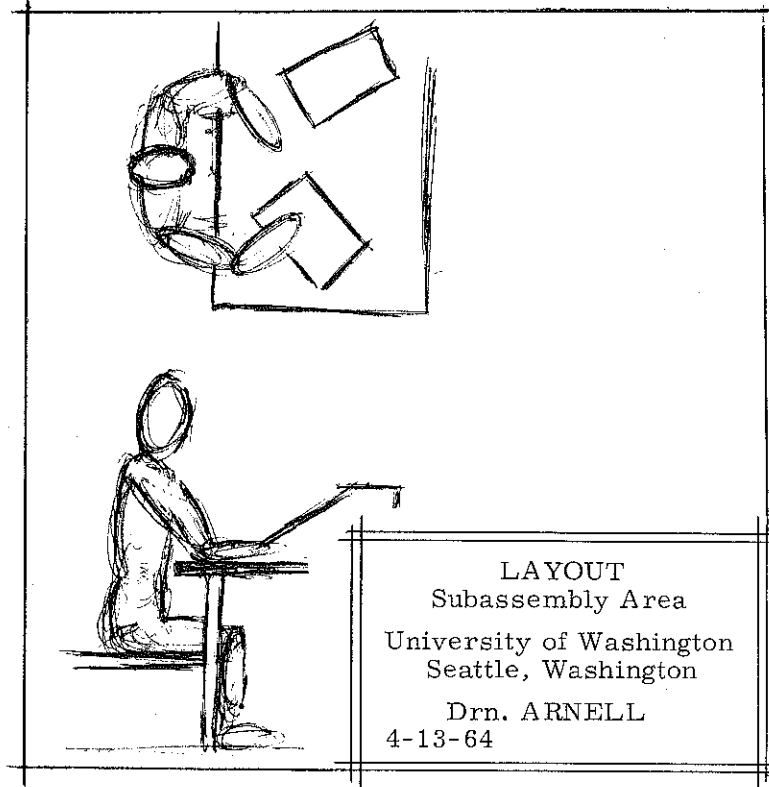
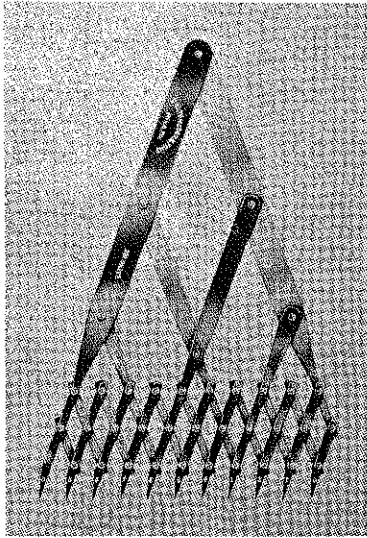

Figure 4

The reactions of the students to these preliminary discussions of design and creative thinking were favorable. They expressed enthusiasm for the approach of the course



THE SPACING DIVIDER



No. 2960—6 INCH
(ILLUSTRATION HALF SIZE)

This instrument consists of eleven points so adjusted that they divide their variable setting into ten or less equal parts. It can also be used inversely to give multiples up to ten and in graphic solution of ratios. Adjustable distance between points on the 6 Inch Instrument is minimum $\frac{3}{16}$ " , maximum $\frac{5}{8}$ " and on the 12 Inch minimum $\frac{1}{4}$ " , maximum $1\frac{1}{4}$ " .

Catalog on Request Covering:

Drawing Instruments

Protractors

Rolling Parallel Rules

11 Pt. Spacing Dividers

Drafting Scales

S.S. Straightedges

S.S. T-Squares

S.S. Triangles

Circular and Linear Engraving

for the

DRAFTING ROOM—PATTERN LOFT—LAYOUT TABLE

THEO. ALTENEDER & SONS

Makers of Fine Instruments Since 1850

1217 Spring Garden Street

Philadelphia 23, Pa.

DISTINGUISHED SERVICE CITATION



by the
ASEE DIVISION OF ENGINEERING GRAPHICS
to



WARREN J. LUZADDER

For outstanding devotion to the interests of his engineering students and to the Division of Engineering Graphics of the American Society for Engineering Education, the Division bestows upon Warren J. Luzadder its highest honor, the Distinguished Service Award.

The Distinguished Service Award recognizes inspired teaching of students in engineering, descriptive geometry, and other graphics courses. The Award recognizes exemplary scholarship both in the classroom and beyond the university confines, evidenced by contributions to the literature and by calls to significant performance in related industry. Above all other considerations, the recipient of the Distinguished Service Award must have made important contributions to the work of the Division over a period of many years.

Warren J. Luzadder, Professor of Engineering Graphics at Purdue University, has served in virtually every office of the Division, notably as editor of the Journal of Engineering Graphics for three years, 1952-55, and as Chairman of the Division, 1957-58. He has attended every Annual Meeting since 1943. During all these years Professor Luzadder has given all-pervading inspiration to his colleagues in the Division of Engineering Graphics.

The Division takes honor upon itself by presenting its 1964 Distinguished Service Award to Professor Warren J. Luzadder.

Irwin Wladaver, Committee Chairman

RESPONSE TO CITATION

I accept this great honor knowing that in parts it must be shared with others for the accomplishments for which one often receives credit results from the efforts and sacrifices of many. First, it must be recognized that two parts, neither one being small, belong to my wife who has helped greatly along the way and to two sons, who during their younger years, were forced to give up the companionship of a father who was always busy.

Next, it is rightful to acknowledge that other parts, of varying proportions, belong to my many colleagues in the Graphics Division and associates on the Purdue campus. Without encouragement, advice, and help of these people the achievements for which this Distinguished Service Award is being given could not have been realized.

Since it is the privilege of one who receives this award to present some words of wisdom, I would like to leave you with this thought which is uppermost in my mind at this time.

Now and then in one's lifetime, one should pause and take inventory of his accomplishments and in so doing realize how much others have contributed to the tasks, which when creditably done, have been the stepping stones leading to the successful life that he personally enjoys. With his humility thus revitalized he will then be in a position of strength from which to continue to make an all-out effort to serve others and not himself.

I have attended every Annual Meeting of the Society for many years to be with the finest group of people in the world - the members of the Graphics Division and their wonderful wives. During these years, it has been both a privilege and a pleasure to serve the Division and the interest of graphics.

My wife and I thank all of you for this great honor. We will remember the moment of receiving this award for the rest of our lives. Thank you again.

Warren J. Luzadder



Efficient, Economical Equipment for Engineering Education

PARAGON Chalkboard AUTO-FLOW® Drafting Machine

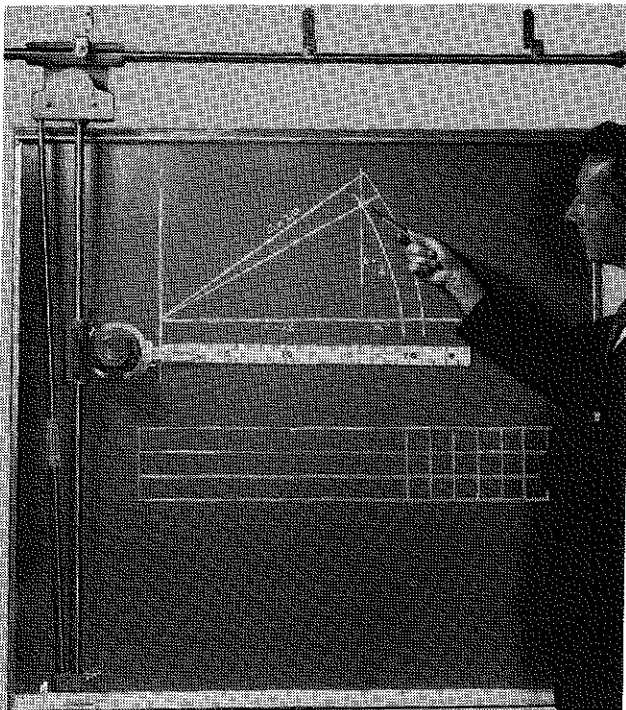

Facilitates preparation of neat, effective, understandable, precise, professional-looking drawings, graphs, tables, diagrams, charts and similar material. Improves teaching effectiveness.

PARAGON® JR. Desk Size Drafting, Design and Layout Machine

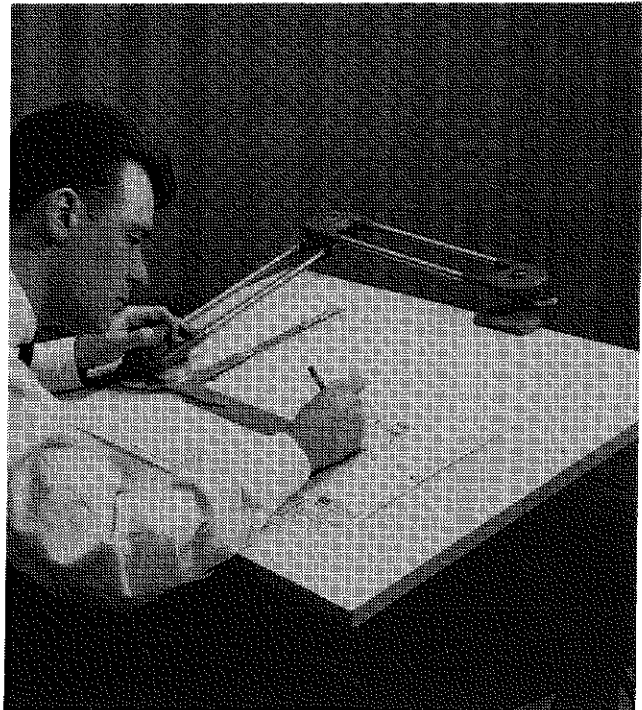

Enables the student to work in class the way he'll work in industry; helps to get more work done quicker and better. Clamps on any board, desk or table.

Specify them for

ENGINEERING • MATHEMATICS • SCIENCE • TECHNOLOGY • ARTS • RESEARCH

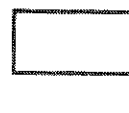

educational division

KEUFFEL & ESSER CO.

Hoboken, New Jersey



Thursday, January 21, 1965

Thursday Noon - For early registrants - unofficial tour or tours - To be announced.

1965 MID-YEAR MEETING

The 1965 ASEE Mid-Year Meeting of the Graphics Division will be held January the 22nd and 23rd. The sponsoring institution is the University of Florida at Gainesville, with Florida State University at Tallahassee, and the University of South Florida at Tampa acting as co-hosts. Rather than have the meeting immersed in campus academic activities, due to the Florida Tri-mester plan of operation, an off-campus site for the meeting was selected.

The Causway Inn in Tampa, Florida, is ideally situated for the meeting. The Tampa-St. Petersburg area offers numerous social and recreational activities, and the site itself is beautifully accessible by car and air transportation.

Florida teems with winter tourists, at this time of the year, the majority of whom are willing to spend freely as compensation for their escape from northern wintry temperatures. However, because of the high character of the Graphics group your meeting chairman was able to make a housing deal at about one-half the normal winter costs. Same housing prices will prevail, if members choose to promote an extended vacation, and arrive a few days earlier, or stay longer.

A healthy, diversified program has been planned and the theme of the meeting will be Engineering Concepts through Graphics, so whatever concepts your Missus and kids may conceive as an excuse for attending at least one Mid-Year meeting -- and in Florida -- don't fight it. Just strive to shave down your contemplated Christmas expenses and start planning.

You will be receiving more detailed literature soon, and many of your questions on transportation, weather, recreation, and costs will be answered.

Y'all Come, Hear!

E. W. Jacunski
Your Chairman

Sponsoring Institution: University of Florida,
Gainesville

Co-Hosting: Florida State University, Tallahassee
University of South Florida, Tampa

Site: Tampa - Causeway Inn, Courtney Campbell Causeway

Time: January 22nd - 23rd, 1965

Theme: ENGINEERING CONCEPTS THROUGH GRAPHICS

- 4:00 - 9:00 p.m. - REGISTRATION
- 7:30 - Executive Committee Dinner and Meeting
- 7:00 - 10:00 p.m. - Social Hour for others

Friday A.M., January 22, 1965

- 8:00 - 10:00 a.m. - REGISTRATION
\$3.00 per member
\$1.00 for wife
- 9:30 - a.m. - Greeting - E. W. Jacunski, U. of Florida
- 9:35 - a.m. - Welcoming Address
Dr. J. S. Allen, President, U. of South Florida

GENERAL PROGRAM

- 9:45 - a.m. - Presiding - R. H. Hammond
Subject - Constructing a Cross-State Canal
Speaker - Col. Giles F. Evans, Jr., Manager
The Canal Authority of the State of Florida
- 10:45 - a.m. - Subject - Graphics in Research
Speaker - Chas. R. Cozzens, Texas A & M
- 11:45 - Picture Formation

Friday Afternoon, January 22, 1965

- 12:15 p.m. - Luncheon - General
Presiding - J. H. Porsch, Purdue University
- 1:00 p.m. - Subject - GENESYS in Florida
Speaker - T. L. Martin, Jr., Dean U. of Florida
- Implementation of GENESYS
Speaker - D. R. Steele, Southern Bell Tel & Tel
- 2:00 p.m. - Presiding - John F. Twigg, U. of South Florida
Subject - Bio-Medical Engineering
Speaker - Dean Joseph Weil, U. of Florida
- 3:00 p.m. - Subject - Graphics in Medicine
Speaker - R. O. Beach, Director of Medical Illustration, J. Hillis Miller Teaching Hospital, U. of Florida
- 4:00 p.m. - Committee Meetings
- 6:30 p.m. - Annual Banquet
Presiding - R. H. Hammond
Entertainment - U. of South Florida
Speaker - E. W. Kopp, Dean, College of Eng. U. of South Florida

Saturday A.M., January 23, 1965

- 8:00 a.m. - Social Hour
- 9:00 a.m. - Presiding - Prof. J. M. Plant, School of Eng. Science, Florida State University
Subject - Engineering in Orbit
Speaker - P. O. Siebeneichen, Launch Operation Center, Cape Kennedy
- 10:00 a.m. - Subject - Oceanography - An Engineering Frontier
Speaker - Dr. Wm. C. Knopf, Dir. of Institute of Marine Science, U. of Miami
- 11:00 a.m. - Subject - The Golden Age for Engineering
Speaker - Dr. M. M. Boring, Bradenton, Florida
- 12:00 Noon - Luncheon - Dutch

On Your Own for Tours, Swimming, Fishing, Golf.
ENJOY FLORIDA

LADIES' PROGRAM - To Be Announced



EDITORIAL BOARD CHANGE

The following recommendations of the Policy Committee of the Graphics Division regarding the Editorial Board of the Journal of Engineering Graphics were approved at the Annual Meeting at the University of Maine, June 1964.

1. EDITORIAL BOARD

The Policy Committee of the Division of Engineering Graphics of ASEE recommends:

- a) That the Editor or Editor-elect of the Journal of Engineering Graphics make a yearly nomination of a two (2) member Editorial Board to assist with editorial duties of the Editor.
- b) That nominations for the Editorial Board for the succeeding year be submitted to the Executive Committee for approval at the Annual Meeting of the Division.
- c) That this Editorial Board be members of the Publishing Board of the Division as defined in the By-Laws. Of the members of the Editorial Board, only the Editor will be a member of the Executive Committee of the Division. (Advertising Manager and Treasurer-Circulation Manager are also members of the Executive Committee.)
- d) That members of the Editorial Board be eligible for renomination at the desire of the Editor.

2. REVISION OF CONSTITUTION AND BY-LAWS TO CONFORM WITH RECOMMENDATIONS IN ITEM 1.

ARTICLE V. DUTIES OF OFFICERS

7. . . .

- b) (Replace present paragraph with:)
The Editorial Board which is comprised of the elected Editor and two assisting members shall select and edit all articles and arrange for publication of the Journal of Engineering Graphics. The Editor or Editor-elect shall annually nominate two candidates for the Editorial Board to serve for the succeeding year. The nominations shall be submitted for approval of the Executive Committee at the annual meeting of the Division. The Editorial Board shall work in close cooperation with the Division Editor, recognizing that ASEE has a prior claim on any papers presented at the annual and mid-year meetings of the Division. The Editorial Board is a member of the Publishing Board for the Journal of Engineering Graphics. The Editor shall serve as a member of the Executive Committee. 

PERSPECTIVE continued from page 14

The teacher should never allow himself to be drawn into an argument in a class session. Discussion, yes. Argument, no. If there is some question that you cannot answer, do not make the mistake of trying to bluff the students. If so, they will mark you down as a phony. Give the right answer if you know it; otherwise, admit that you don't know, and promise to look it up. Give them the answer at the next class meeting.

Teachers are often lazy about grading. Some teachers work out all sorts of schemes to cut down on grading, such as letting the students grade each other, or simply omitting the grading of everything except exams. In my opinion, the teacher should grade everything he assigns, and should do so conscientiously. If possible, he should grade the drawing in the presence of the student, so that all errors can be pointed out. And don't forget: point out the good things as well as the errors. Encourage him!

All teachers throughout a department should use the same system of grading - that is, the mechanics of the system should be the same. Grading should be as objective as possible. The young instructor would do well to let an older teacher examine his grading from time to time to make sure that he is not too tough or too generous with his marks. My experience has been that the beginning teacher is apt to be too hard in his grading. After a few years he will generally become more understanding and generous. 

2

Report Your Teaching Improvement Project!!

The Teaching Techniques Committee welcomes any information regarding teaching improvement projects in progress and would like to assist in bringing the results to our groups through encouraging the originators to participate in meetings at all levels and in publication.

Committee members are seeking teaching methods, devices and procedures that may be presented to improve the teaching of graphics.

Current interest has been in following up studies in the television field, the use of overhead projection and the use of programmed instruction and teaching machines.

Commercial and individual classroom efforts and devices are equally of interest. What the individual is doing often is a basis for the most informative, entertaining and useful contribution.

Our changing subjectmatter demands research. Only an informed committee can contribute. Let the committee know what you are doing.

Engineering Graphics Division TEACHING TECHNIQUES COMMITTEE:

H. P. Ackert, U of Notre Dame, Chairman

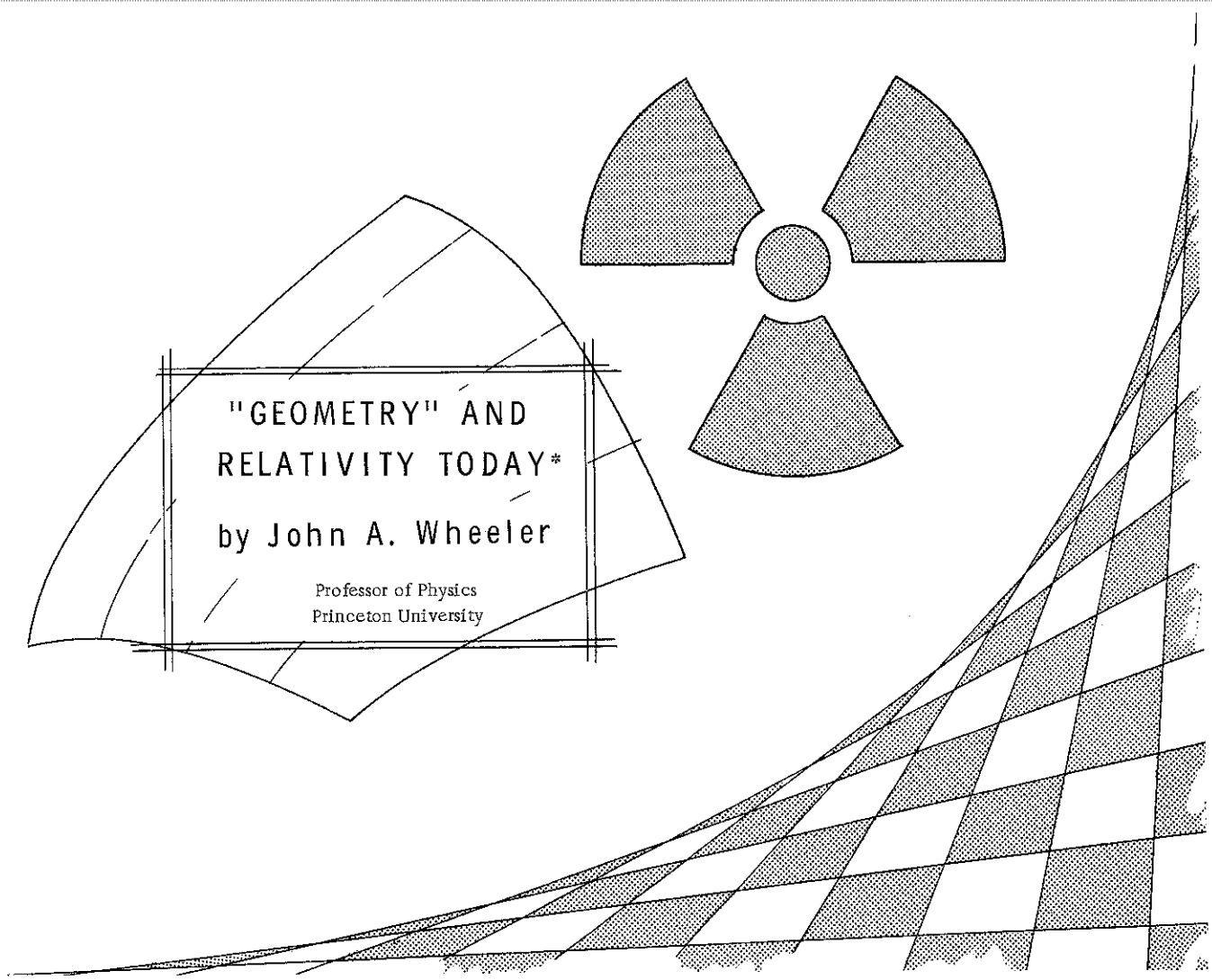

What will happen if one gathers together a great collection of matter? What new physical process will go on when the mass is very great and very highly compacted, when the pressure inside becomes enormous and the curvature of space, calculated in accordance with Einstein's general relativity, approaches an infinite value? Will the matter at this point be crushed out of existence? Is there any escape from accepting the existence of a new and so far unobserved physical process in which neutral matter is transformed completely into radiation? I know of no question which links more decisively the world of elementary particle physics and the world of general relativity. I suspect that out of the observational and theoretical study of this question will come new clues as to the relation between matter and the curvature of space.

The matter in a real star, compressed to high density, poses complex problems of nuclear structure and nuclear stability. Can one set those problems aside for a first look at the issue of the critical mass? Is there not some star-building substance which is simpler in its constitution than ordinary matter? Fortunately there

is! In a hot star there is present not only matter but also radiation. This radiation possesses energy. This energy has mass, according to Einstein's relation between energy and mass. In theory, therefore, it is not necessary to have any real mass at all in order to be able to construct a star as massive as one pleases. Radiation cannot be trapped by the gravitational pull of radiation or of anything else if it is traveling radially. A packet of radiant energy is an ideal bullet if it is fired straight up because it will never fall back on the earth - or the star - from which it starts out! But if the radiation travels tangentially - or nearly tangentially - then a sufficiently great gravitational force can bend its path and hold it in orbit. And the mass it takes to do this orbit-bending can come entirely from the mass of radiation itself. Thus one can in principle build up a model star of a kind not seen in nature, made exclusively of radiation. This model star has been given the name Gravitational Electromagnetic Entity (geon), and later received detailed analysis on an electronic computer. The geon acts at a distance like any other

mass. It attracts other objects toward itself. It in turn is attracted towards them and deflected one way or the other in its travel through space. Yet viewed close up it is totally devoid of any real mass. Nowhere in its interior is there anything but curved empty space - space empty of anything but an entity so tenuous as an electromagnetic field!

ARENA OR EVERYTHING?

If there ever were such objects as geons in the natural universe, we may be pretty sure there are none now. A geon, something like the size of a star, sweeping through space would pick up on its way a great deal of dust, grains of matter and atoms. The large electromagnetic fields in the interior of the geon would accelerate these charged particles, driving them out as cosmic rays. There are too many sources of cosmic rays already, so this doesn't provide one with a unique tool to look for geons, but it does say in effect that there is a mechanism of dissipation of energy from geons in the real physical world, which is so effective that a geon would have its energy sopped up by dust in a time so short on an astronomical scale that there should be no geons left at this time.

However, the concept of the geon has importance for another reason. It forces us to recognize that Einstein's theory of relativity has a far richer family of consequences than have so far been read out of the theory. The central question is inspiring. What is the function of space and time? Do they merely provide an arena within which fields and particles move about and interact with each other? Or is the space-time continuum - in some sense that we perhaps do not fully understand - a kind of magic building material out of which everything is made? Is space-time a kind of magic dough which is slowly curved in one way here, describing gravitation; rippled in another way there, that we interpret as an electromagnetic field; and twisted up in a knot somewhere else, manifesting itself as a concentration of mass and energy that looks and moves like a particle? In brief, is space-time an arena, or is it everything? It is only fair to say that Einstein himself was animated by the vision that space-time is "everything."

Let us say then that there is a view of nature which would regard all of physics - all matter, all energy, all forces - as a manifestation of pure geometry. But if we want to try to regard all of physics as pure geometry which evolves with time but which still contains nothing but emptiness - then a word more descriptive than "general relativity" of what we are talking about is "geometrodynamics." This word geometrodynamics implies not only a world - even though only a "model world" - built out of pure geometry, but also a geometry developing with time according to a definite dynamical law.

The dynamical law for the change of geometry with time is just as well known from Einstein's

1915 theory as the laws of electromagnetism are known now and were known in the last century from James Clerk Maxwell's publication of 1864. Maxwell's theory of electromagnetism today supplies the master principles for many branches of technology. The law for the evolution of electric and magnetic fields in time has been tested thoroughly over an enormous range of distances, from thousands of kilometers down to a small fraction of the diameter of the atomic nucleus. One had no right to expect Maxwell's laws to stand up - as they do - without exception. The original experiments upon which they were based ran only over the range of distances from meters to millimeters. Evidently there is a power of extrapolation in a really basic physical law which goes far beyond the reach of the pioneer measurements. One is forced to ask does a similar power of extrapolation reside in the law of geometrodynamics? This law of Einstein, developed to account for gravitation, is based on observations of falling bodies. It is confirmed by the bending of light by the sun and by the precession of the axis of the elliptical orbit of the planet Mercury from century to century. Can we apply this law at distances as great as the sweep of the universe (10^{28} cm)? Can we apply it down at the fantastically small distances of 10^{-33} cm, ultra-microscopic even compared to the dimensions of elementary particles, where quite new effects may show up? We don't know. We can only trace out the observable consequences of this law and see if they agree with experience.

FLIGHT IN A THICK FOG

Any direct check on these fluctuations in geometry appear quite out of the question. Elementary particles are far too coarse to be of any service as test particles to probe geometry down to this almost unimaginable scale of fineness. But the existence and well-known properties of the elementary particles may in the end - in the long distant end - provide the data best suited to checking the principles of quantum geometrodynamics. But if experiment cannot carry us down to the very smallest distances - and today we see no possibility that it ever can - then how far can we get in projecting theory down to 10^{-33} cm?

Every era of science has its own methods and its own outlook, forced upon it by the nature of the problems with which it is grappling. As we struggle to understand the structure of space-time down at the very smallest distances, we find ourselves forced into extrapolations beyond any parallel in all the rest of physics. Never before to move forward have we had to put such trust in theory unguided by hosts of experiments. The physics of the past can be compared with an airplane trip across the Caribbean - island hopping, stopping here and there to check one's bearings, verifying that one is the right route. But the enterprise facing modern physics is more like a trans-atlantic flight in thick fog! One does not start on a trip such as I have described if he lacks faith in his chart. Why then

Einstein's theory? Why not some other theory? Many theories of gravitation have been proposed. But not one of them compares with geometrodynamics in simplicity, in comprehensiveness, and in agreement with experiment. No other theory of gravitation and space-time has the deep philosophical background and the ties with Newtonian gravitational concepts which characterize Einstein's theory.

Two currents of thought found their unison in Einstein's theory. One goes back to Bernhard Riemann (1826-1866), the other to Ernst Mach (1838-1916). The argument of Mach was that the inertia of a particle originates not through some mystic magic properties of space, but through its interaction with all the other matter in the universe. Einstein found that gravitational forces - not the usual static gravitational forces, but the radiative or accelerative part of gravitational forces - provide an account of the origin of inertia which is in harmony with Mach's principle.

WHAT IS CURVED SPACE?

The other heritage decisive for general relativity was the concept of a curved space. Many of the foundations for thinking about curved space in quantitative terms were laid in 1954 by a young man of 28 in his inaugural lecture at Gottingen. Riemann spoke "On the Hypotheses which Lie at the Foundations of Geometry." He recalled that the length of the hypotenuse of a right triangle is not equal to the square root of the squares of the two shorter sides when the triangle lies on a curved surface such as the surface of the earth. He raised the question whether the space of the physical world is flat or curved. He emphasized that this question could not be settled by an appeal to pure reason - that it required experiment or observation. His colleagues soon after took themselves to three mountain peaks near Gottingen and measured the sum of the angles of the triangle thus defined. Observations could not then - and cannot now - be made with sufficient precision to detect any departure of this sum from 180° . Only in these later years have we returned to the same question under the inspiration of Einstein's theory. We have shifted our gaze from the geometry of space near the earth to the bending of light by the greater mass of the sun. We have found the kind of evidence for curvature that would have delighted Riemann.

Riemann thought of the curvature of space as being significant not only at astronomical distances, but also at small distances: "The empirical concepts of light ray and material body . . . seem to lose their validity at very small distances; therefore it is quite conceivable that the geometry of space at very small distances does not satisfy the axioms of Euclidean geometry; and one would be forced to make this assumption, if in this way the observations could be explained more simply."

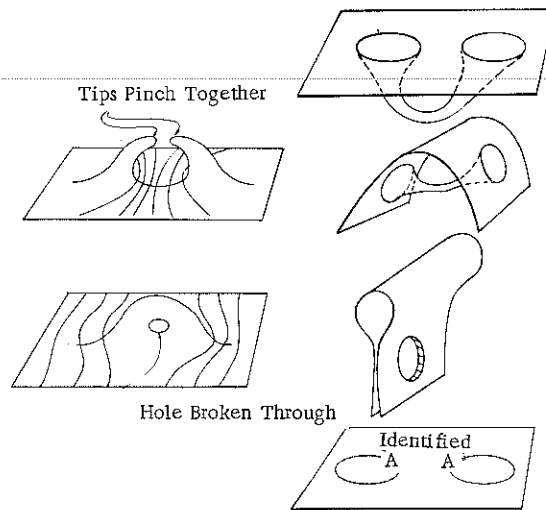

Figure 1

The diagrams above represent a two-dimensional analogy of the concept of a doubly connected space, or "wormhole." The two drawings at left show how two different regions of a plane become connected as the curvature of space increases, the two upward prongs joining to form a wormhole. The other four drawings show the plane from the other side, indicating how the edges of the wormhole are identified by bending the plane. Such a topological surface allows two methods of travel from one point to another: the first in regular fashion across the surface of the plane, the second down the wormhole. The latter route would take literally no time at all, and to an observer in this space, an ant using the wormhole would seem to disappear at the edge of one circle to reappear at the identified point on the edge of the other.

Let me quote Einstein's own words about Riemann: "Physicists were still far removed from such a way of thinking. Space was for them a rigid homogeneous something susceptible of no change or conditions. Only the genius of Riemann, solitary and uncomprehended, had already won its way by the middle of the last century to a new conception of space, in which space was deprived of its rigidity and in which its power to take part in physical events was recognized as possible."

What does it mean for space to be curved? How dismaying is one's first meeting with this idea! Even more upsetting, it is not merely 3-dimensional space which is curved - Riemann's concept - but 4-dimensional space-time - Einstein's deeper insight.

It is clear enough what one means by the curvature of the hull of a ship that lies over on her side. One can at least drive nails into the wood, measure distances between these nails on that surface, and verify by these distance measurements that the surface is curved. But how is one going to drive nails into space-time?

Perhaps an analogy will make the concept somewhat easier to think about. Compare space-

Two completely new workbooks designed to accompany---

ENGINEERING GRAPHICS

JAMES S. RISING and MAURICE W. ALMFELDT

ENGINEERING GRAPHICS

problem book

1

\$3.50

JAMES S. RISING

*Professor and Head of Engineering Graphics
Iowa State University of Science and Technology*

CARL A. ARNBAL

*Assistant Professor of Engineering Graphics
Iowa State University of Science and Technology*

Outstanding Features include:

- Problems for one semester of Engineering Graphics, 6 class hours per week.
- Keyed to Engineering Graphics by Rising and Almfeldt.
- Covers first 16 units of text.
- Contains 76 sheets of problems for solution.
- Layouts for practice of graphical theory, engineering applications and worded problems.
- Paper available in back for worded problems, quizzes, and extra work.
- High quality green tinted drawing paper for all problems.

ENGINEERING GRAPHICS

problem book

2

\$4.50

MAURICE W. ALMFELDT

*Professor of Engineering Graphics
Iowa State University of Science and Technology*

CARL A. ARNBAL

*Assistant Professor of Engineering Graphics
Iowa State University of Science and Technology*

Outstanding Features include:

- Problems for one semester of Engineering Graphics, 6 class hours per week.
- Keyed to Engineering Graphics by Rising and Almfeldt.
- Covers units 17 - 37 of text.
- Contains 88 sheets of problems for solution.
- Emphasis on application of problems in the several fields of engineering.
- Vellum paper, size 11 x 17.
- Graph paper in 10 x 10, log, and semi-log for the graphical analyses found in units 33-37.
- High quality green tinted drawing paper, size 8 1/2 x 11.

NOW . . . You can TAILOR-MAKE your own workbook!

IF you have sizeable classes we can prepare for you special workbooks containing problems of your choice. You may select problems from the above two new workbooks or from our stock of more than 180 additional problems. Samples of all of the problems will be furnished upon request. Your problem books will be made to your own specifications—you may make up 2, 3 or more to precisely fit your needs. Write us today for complete details and samples of the problems.

WM. C. BROWN BOOK COMPANY

135 SOUTH LOCUST STREET • DUBUQUE, IOWA 52003



About the All New (1964) Third Edition of ---

ENGINEERING GRAPHICS

by

JAMES S. RISING

*Professor and Head of Engineering Graphics
Iowa State University of Science and Technology*

MAURICE W. ALMFELDT

*Professor of Engineering Graphics
Iowa State University of Science and Technology*

416 pages

Beautifully Cloth Bound

\$7.25

This text presents the basic principles and graphical theory of communication drawings in a logical and integrated manner. The 490 carefully-designed illustrations demonstrating steps of procedure for problem solutions are supplemented by many pictorial drawings to aid visualization.

Sketching, both orthographic and pictorial, is introduced early. It is felt that freehand work should be stressed continuously wherever rapid and reasonable results can be obtained or where methods for problem solution can be demonstrated.

Innovations in this integrated text include the initial introduction of orthographic or multiview projection by the study of a Point and its spatial location. Experience has demonstrated that the student can better visualize the principles of projection applied to a point in space rather than to a solid object, with the complications offered by invisible edges and surfaces. The next logical step joins two points to form a Line, with succeeding steps to develop basic theory of the Plane and the Solid. The essential topics of graphical theory, commonly called descriptive geometry, are integrated throughout the text.

Standards and conventions used to communicate general size specifications immediately follow the shape description of solids. Comprehensive treatment of production dimensioning and working drawings is deferred until the student is more graphically mature.

The material on vector geometry, the graphical calculus, and simple alignment charts is scaled to come within the comprehension and ability of the engineering freshman.

Practice problems from the several fields of engineering, illustrating principles previously discussed, are presented at the end of each unit of study.

TABLE OF CONTENTS

Introduction
Freehand Drawings
Engineering Lettering
Drawing Instruments and Equipment
The Theory of Orthographic Projection — Points
The Theory of Orthographic Projection — Lines
The Theory of Orthographic Projection — Planes
The Theory of Orthographic Projection — Solids
Sections and Conventional Practices
Specifications — Basic Concepts
Pictorial Drawings — Axonometric
Pictorial Drawings — Oblique
Pictorial Drawings — Perspective
Spatial Geometry — Points and Lines
Spatial Geometry — Lines and Planes
Problem Solutions by Rotation
Plane and Single-Curved Surfaces — Generation
and Development
Double-Curved and Warped Surfaces — Generation
and Development
Surface and Solid Intersections

Production and Reproduction of Drawings
Processing Methods and Procedures
Standard Fasteners — Threaded
Fasteners — Removable and Permanent
Production Dimensioning and Standard Specifications
Application Drawing — Mechanical
Application Drawing — Piping and Weldments
Application Drawing — Electrical
Application Drawing — Construction
Application Drawing — Simplified, Automation
Engineering Illustration
Geometry of Plane Vectors
Geometry of Space Vectors
Graphical Representation of Data
Graphical Mathematics — Arithmetic and Algebra
Alignment Charts
Graphical Calculus — Differentiation
Graphical Calculus — Integration
Appendix
Index

Features of the All New Third (1964) Edition: -

- Set in Type • 2 column pages • large, easy-to-read type
- many new illustrations • better position with respect to reading material • Some larger drawings
- more step-solution drawings
- completely new introduction to orthogonal projection — both illustrations and explanation.
- unit on Production Dimensioning has been enlarged and includes ASA cylindrical parts.

- additional material is included on positional and geometrical tolerancing.
- Individual units on: Mechanical, Construction, Pipe and Weldments, Electrical, Simplified and Automation, as related to Application Drawing.
- new problems added at the end of many units.
- new unit on Graphical Algebra.
- Z or N charts added.
- Concurrency charts added.

—COMPLIMENTARY COPIES AVAILABLE UPON REQUEST—

WM. C. BROWN BOOK COMPANY

135 SOUTH LOCUST STREET • DUBUQUE, IOWA 52003



time with a barn full of hay. To move upward from the floor of the barn is comparable to progressing ahead in time. Each straw is like the track of a particle through space-time. The points where two straws cross and bend each other is comparable to the collision between two particles. Every such collision is what Einstein calls an event in space-time. Such events can be distinguished from each other and labelled without any recourse to distance measurements. These events - these collisions - take the place of the nails that one drives into the hull of the ship to determine its curvature.

I know of nothing that illustrates the concept of curved space so well as one of those little diaries that lists the airline distances between the principal cities of the world. For instance, take a huge sheet of clean white paper, a sharp pencil and a ruler, put down one dot for Buenos Aires, measure off the scale distance to Tokyo. From both these points measure off the appropriate distances to New York and find precisely where this third dot has to be located. Then try to find Panama. Work as you will, you cannot find any place on the paper to put a dot which will make its distances to Buenos Aires, Tokyo and New York come out right. It is necessary to raise Panama up in the air to make the distances come out right: it was a mistake in the very beginning to use a flat sheet of paper. The entire table of distances spells out a rigid framework of points, but these points have to run through a curved surface, not a flat piece of paper. From following the table of airline distances - and nothing more - one can deduce not only the shape of the earth but even its radius of curvature! The same idea applies to Einstein's space-time. Given a table of the distance in the 4-dimensional world between each event and every other event, all the data is at hand to define the entire geometry of space-time.

It was not enough, however, for Einstein merely to describe a curved 4-dimensional space-time and to spell out its properties. To select out from amongst all conceivable events those which can actually occur in nature, one requires in addition to pure description a dynamical law. The distinction between conceivable history and allowable history is commonly made in mechanics, for instance, by dividing this subject into kinematics, the description of motion, and dynamics, the selection of allowable motions. The dynamics of geometry in Einstein's theory is described by ten equations. These equations may be said to provide the basic law of geometrodynamics, the law that distinguishes between the merely conceivable structures of space-time and the space-time that occurs in our physical world.

Happily ways have been found in recent years to state with new simplicity the contents of Einstein's geometrodynamical law, as one has also found new ways to state the content of the electro-dynamical law of James Clerk Maxwell. These two dynamical laws plus the quantum

principle provide today a set of principles of greater beauty and greater scope than we have ever had before in physics. Therefore it may be appropriate to look at the nature of these two dynamical laws, beginning with that of Maxwell.

One of Maxwell's equations states that electric lines of force never end except on electric charges. Another states that magnetic lines of force never end anywhere. Both statements describe relationships in space at a particular time. The asymmetry between space and time in the formulation of these equations can bear a closer look. Let space-time be symbolized by the space in a room. Let "up" represent the direction in which time is increasing. Then a plane horizontal to the floor makes a slice through space-time. The directions of travel on the plane - left and right, forward and backward are spacelike directions, while motion up from the plane is timelike. If you think of electric and magnetic lines of force traced out on the plane in red and green ink, you can verify Maxwell's two equations by seeing whether green lines ever come to an end, and whether red lines ever end except at the location of an electric charge.

SLICES OF SPACE-TIME

The distinction between space and time is however one which makes sense only to a particular set of observers. A second set of observers in motion with respect to the first set will define differently the distinction between space and time. What to these moving observers is a spacelike slice through space-time will appear to us as a plane tilted away from the horizontal. What they say about electric and magnetic lines of force nowhere disappearing in this tilted plane will appear to us as quite different and new information. Translating this information into everyday terms, we learn that moving charges create magnetic fields and that magnetic fields which change with time create electric fields. This supplementary information about electromagnetism is the content of the remaining equations of Maxwell's theory. But we see that we do not need these additional and more complicated equations if we want to grasp the law of electrodynamics in its simplest form. We have only to state that lines of force never end (except on charges) and simply repeat the statement for every slice through space-time in order to have before us the entire content of Maxwell's equations.

The same procedure works with Einstein's equations. Any slice through space-time defines a 3-dimensional geometry. If we determine both the intrinsic and extrinsic curvature of this 3-dimensional geometry, the numerical difference must be equal - according to Einstein - to the density of mass-energy in the region of space under consideration. If, in addition, we impose this same law on every slice through space-time we have stated the entire content of Einstein's geometrodynamical law of the structure of space-time. This is all there is to general relativity.

ENGINEERING GRAPHICS

"The Magazine Of Engineering Communication" Extends
a cordial invitation to authors
to submit articles for publication .

ENGINEERING GRAPHICS is a comprehensive publication with a unique aim: to report trends, developments, and applications of the communication lines of general engineering - - the measurement, computation, design, drafting and reproduction technologies on which the modern economy increasingly depends.

It has a monthly circulation of over 67,000. A cross section includes engineering professors and professional engineers; registered architects and industrial designers; draftsmen and reproduction engineers; surveyors and technicians; and students of engineering and technology.

The editors of ENGINEERING GRAPHICS would be pleased to receive and review feature - length technical papers on practical applications of engineering techniques; articles on instructional devices and training methodology; and "how - to - do - it" and "reason - why" stories that would be of timely and pertinent interest to practitioners and trainees in the above categories.

Articles should be between 900 and 1500 words in length, illustrated by appropriate photographs or drawings wherever possible. Outlines of proposed stories, submitted for approval, will also be welcome.

Authors Will be paid at our regular rates upon publication.

Manuscripts should be submitted in duplicate - - original and carbon copy - - double-space typed on standard 8 1/2 " x 11 " sheets, together with a self-addressed envelope. All submittals, outlines and inquires will be acknowledged.

SEND MATERIAL TO: The Editor
ENGINEERING GRAPHICS
25 West 45th Street
New York, N. Y. 10036

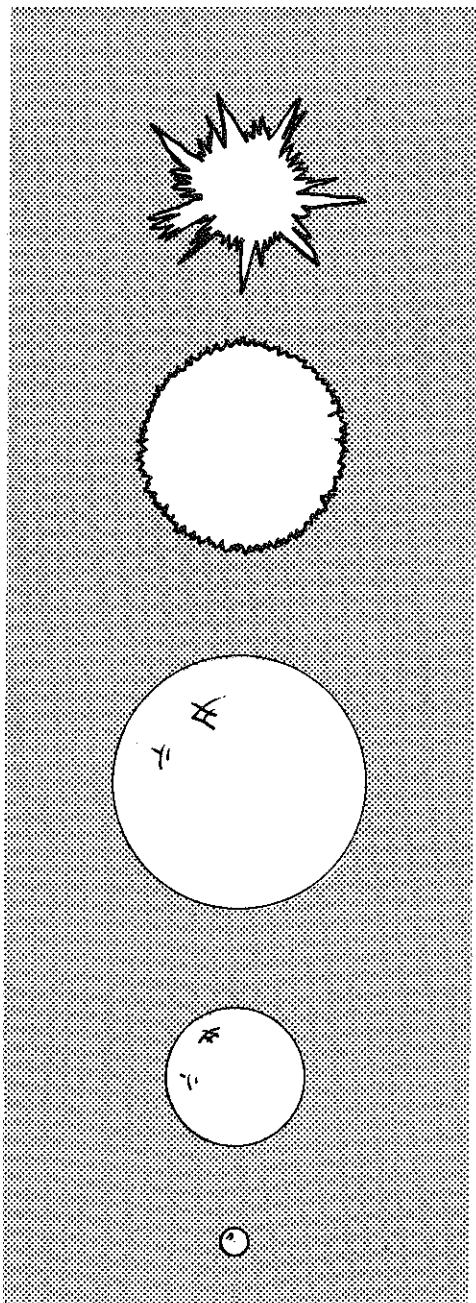

Figure 2

An air bubble rising to the surface of water first expands, then contracts, then breaks into turbulence. Drawing shows a possible analogous model of the expanding universe over a period of time.

REAL MASS OR EMPTY SPACE?

Physicists, however, usually put this geometrodynamical law in slightly different terms, terms such as those generally used in speaking a about electromagnetism, or even about the motion of a bullet. We distinguish between initial conditions and what happens as a consequence of those initial conditions. Given the initial position of the bullet and its initial velocity, we can predict its future motion. Or give the initial strength and direction of electric and magnetic fields: from this information - and from the motion of the charged particles, if any - we can predict the entire future history of the electromagnetic field. Similarly in geometrodynamics

we have only to give the initial three-dimensional geometry throughout all space - and its initial time rate of change - in order to predict all the development of this geometry with time. The initial value data, in other words, is 3-dimensional in character; but it determines an entire history of a 3-dimensional geometry - that is to say, a 4-dimensional geometry.

This way of looking at geometry which has been provided by relativity has within it consequences which can alter our concept of space itself. Let us look again, for example, at the geon. At some arbitrarily chosen time - in other words, on some arbitrary slice through space-time - we have an electromagnetic wave traveling around a circle and a curvature of space produced by this electromagnetic energy that is sufficient to hold the wave in orbit. At great distances there is the same curving of space, the same gravitational pull, as if the geon were made of "real matter." But now this gravitational pull - and the effective gravitational mass that goes with it - originates, not from "real mass," but from curved empty space itself. The origin of the apparent mass can be explained in the following way: the bending of space indicates the presence of a gravitational field. This field has energy associated with it. This energy - like any other energy - has mass. This mass causes a bending of space. Thus a geon affords a view of space is maintained by the curving of space!

Now, if we follow this curved space inward - an enterprise on which Christian Fronsdal at Geneva and Martin Kruskal at Princeton have recently made decisive new achievements - we find that the curvature gets greater and greater until a kind of neck is reached. Proceeding further, the curvature decreases again, and comes out on a new, flat - almost Euclidean - space. Simply by following the implications of Einstein's equations in a most lateral and straightforward way, we have found ourselves forced to accept the possibility of a new kind of topology for space. This topology may be described most readily as a pair of nearly Euclidean spaces connected by a throat or bridge.

Once we see we are reckoning with new kinds of topological descriptions of space, it becomes instructive to consider such a throat connection, not between two Euclidean spaces, but between two different regions of the same Euclidean space. We can best describe such a connection by considering a 2-dimensional analogy.

Visualize, as shown in Figure 1, a paper in which two circular holes have been cut. To the view of the inhabitants of this 2-space, space simply stops at the edge of these circles. We can, however, repair these rifts in space by the simple expedient of identifying each point on the circumference of one circle with the corresponding point on the other circle. We do this by bending the paper so that one hole is superim-



ALLYN AND BACON, INC.

Two Modern Engineering Texts for 1964-1965:

BASIC GRAPHICS: Drawing and Descriptive Geometry

By RICHARD SPRINGER, LEWIS G. PALMER, WILLIAM A. KLEINHENZ and PAUL W. BULLEN, all of the University of Minnesota

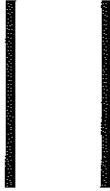

This basic text in graphic communication at the collegiate level stresses the fundamentals of projection or representation of spatial components. Emphasis is of a general nature, and aims at strengthening the student's ability to visualize, analyze, and specify three-dimensional systems. The student is prepared—the way an engineer or scientist should be—in the conceptual aspects of spatial analysis and representation. A problems set is available upon adoption. 1963, 7½ x 10, 380 pages.

COMMUNICATION FOR ENGINEERS

By CHARLES A. RANOUS, University of Wisconsin

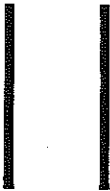

This comprehensive study of speech, writing, and graphic presentations, is designed to show the engineer how to communicate engineering information effectively. The text presents workable means for minimizing communication errors, and discusses how approximately 700 engineers solved problems in writing and speech in research development, production, and field maintenance. Such practical coverage makes this book an ideal reference work for the engineer. 1964, 6 x 9, 183 pages

FOR EXAMINATION COPIES
WRITE TO:
ARTHUR B. CONANT, DEPT. I

ALLYN AND BACON, INC. 150 TREMONT STREET, BOSTON 02111

We are happy to use this means to extend best wishes to our many friends among the readers of the JOURNAL.

While we are no doubt best known as the manufacturer of the Ames Lettering Guide at the right, we would call your attention to other items we manufacture such as:

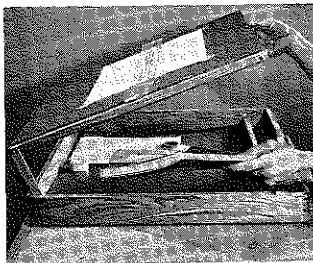

- The Ames Draft-Pak
- Ames bonded acrylic Tee Squares
- Ames Tee Square Guides for perspective drawings
- Ames Stadia Protractors and Visual Aids for drafting rooms

We welcome your inquiries about these products.

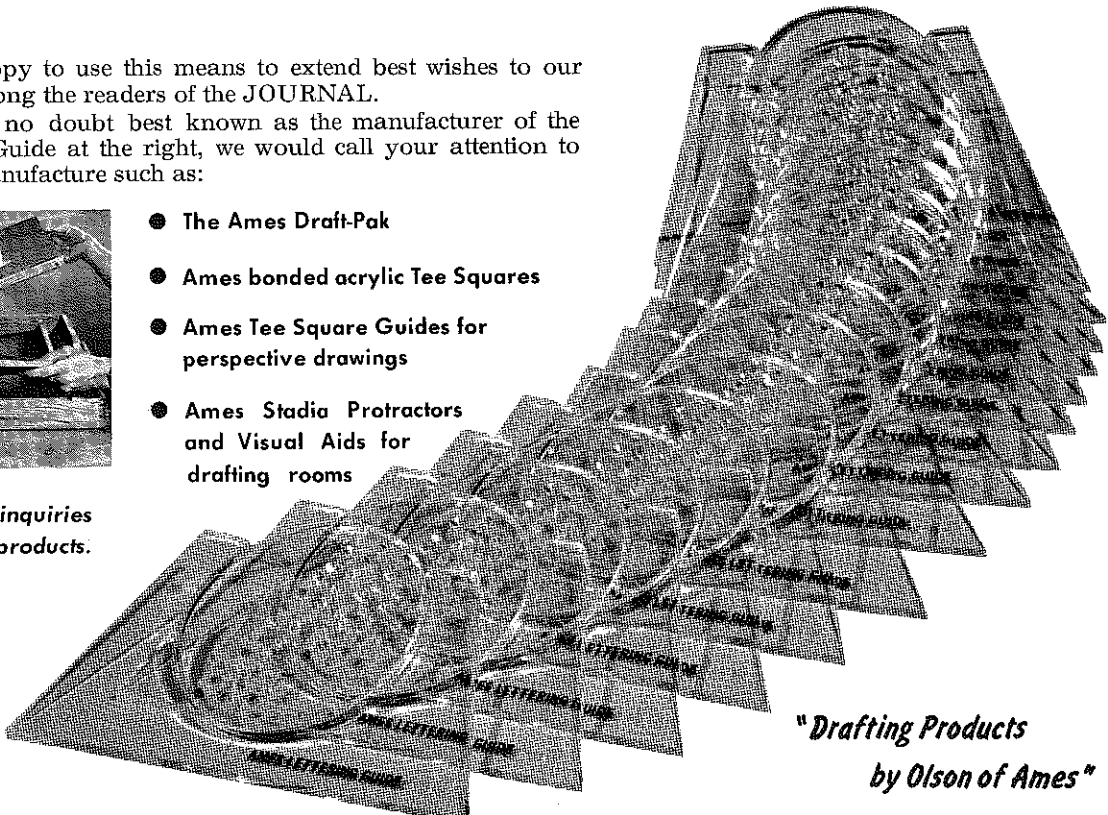
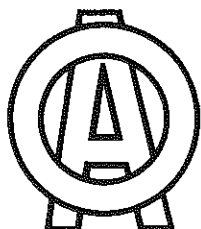

*"Drafting Products
by Olson of Ames"*

OLSON MANUFACTURING CO. P.O. Box 109 • Ames, Iowa

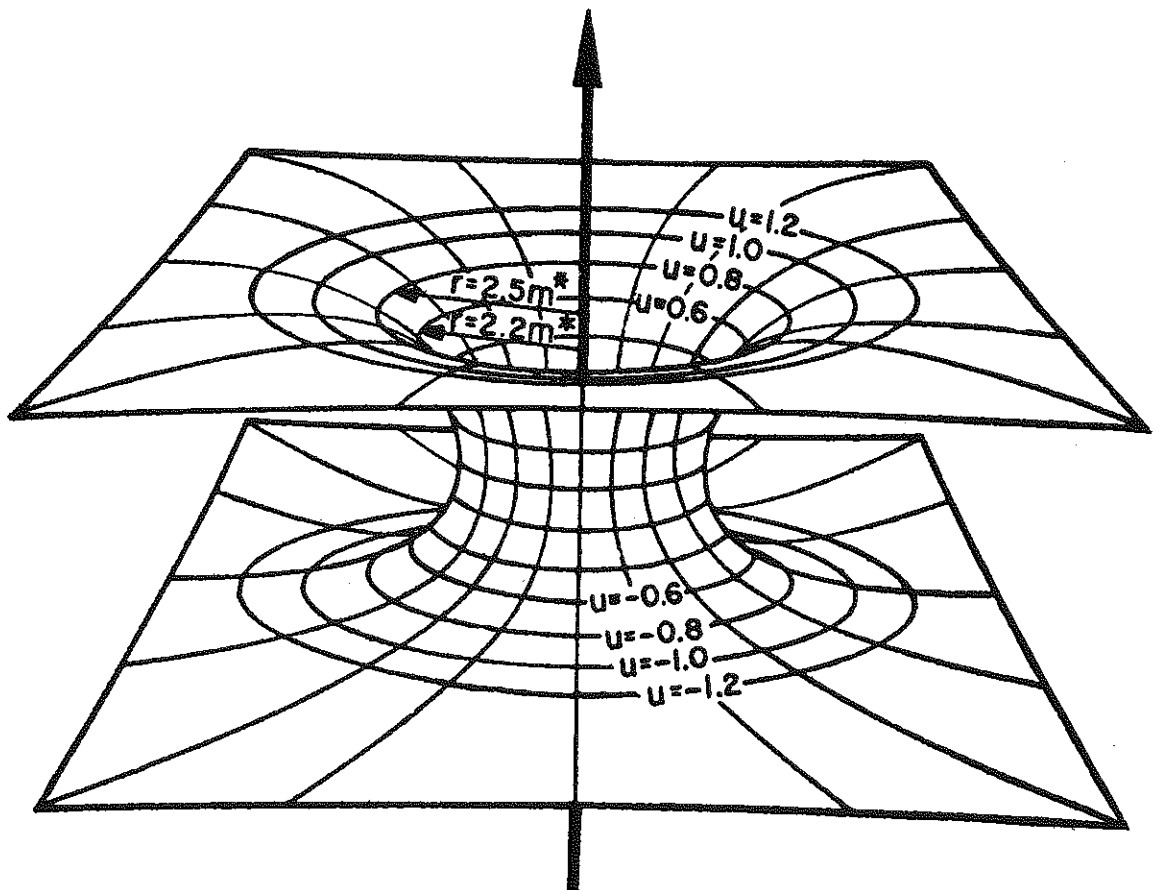

Figure 3

The Schwarzschild solution of Einstein's equations for the curvature of space around the sun, if followed literally, curve in and then out to form a connection between two nearly Euclidean spaces.

posed on the other, and we can easily see further that this operation does not in the least disturb the topology of 2-space. Once we have connected the two circles by identifying the points on their circumferences with each other, it is perfectly permissible to unfold the paper, and again this in no way disturbs the topology of our space. The circles, however, are still connected, as shown in the diagram, by what has been called a "wormhole" by physicists. There are now two routes in this space to get from one point to another. One route proceeds normally across the intervening space; the other uses the "wormhole." This latter method of travel, while understandable to us in light of our topological manipulations, would appear quite startling to an observer in 2-space. Imagine, for example, an inhabitant of a 2-space watching an ant crawl into the circle on the left. Since the two circles are identified a trip down the wormhole would take literally no time, and as the observer watched the ant's head disappear into the hole at the left he would simultaneously see it appearing again out of the hole on the right. To him it would appear as if in some magic fashion the ant was disintegrating at one point and then reintegrating again at a point some distance away. Thus the space we are considering has two modes of travel - one of them considerably shorter than the other.

NOW YOU SEE IT . . .

A space is said to be doubly connected when it offers two such distinct routes to connect a typical point A with a typical point B. Analysis of doubly connected and multiply connected spaces is unfamiliar to any but our mathematical colleagues in the field of topology: Yet as we examine the consequences of Einstein's general relativity we are forced to consider spaces with unusual topologies.

What can go on in a multiply connected space? Imagine, for example, electric lines of force running towards the circle at the right. Maxwell's equations say these electric lines of force can't end except on some negative charge. The 2-space observer will therefore say that there is a big collection of negative electric charge near the right circle. But, if we look more closely the lines of force do not end. They cross the circle on the right hand and then suddenly appear out of the circle on the left. The 2-space onlooker will continue to be deluded and will say that there is a big positive charge of electricity near the left circle. However, to us who look more closely it is apparent that nowhere is there any real electric charge. Rather, we are dealing with a situation where electric lines of force are trapped in the topology of a doubly connected space. We

Engineering drawing and graphics texts from Prentice-Hall . . .

Engineering Communica- tions

Allen B. Rosenstein, *University of California, Los Angeles*; Robert R. Rathbone, *Massachusetts Institute of Technology*; and William F. Schmeer, *Case Institute of Technology*. This is the first book of its kind to apply the theory of communication to the everyday problems of writing and speaking. Especially written for technicians, particularly those in engineering design, this book uniquely combines communication theory with communication practice. For the first time, writing, drafting, and sketching are introduced as indispensable skills. 1964, 160 pp., Paper \$2.95, Cloth \$4.95

Fundamentals Of Engineering Drawing, 5th Edition, 1965

Warren J. Luzadder, *Purdue University*. Specifically designed for the beginning student. The approach makes it a useful guide through all phases of engineering drawing, regardless of the student's background knowledge. ASA and SAE standards and practices are incorporated. A lucid presentation on the use of instruments, lettering, engineering geometry, and multiview drawings, a dictionary-like coverage of the language of the draftsman and the engineer. Over 1200 illustrations, many with surface shading that permit rapid visualization of ideas. New chapters have been added on Tool Drawing and Design, and another on Electronic Drawing. New material has been added on descriptive geometry in the Auxiliary Views chapter. January 1965, approx. 752 pp., \$9.95

Problems In Engineering Drawing, 4th Edition, 1959

To accompany Luzadder's *Fundamentals* (or any other standard textbook)—this is a revision of laboratory practice material which includes a set of 70 standard problems, presented as partially drawn layouts for your students to complete. Printed on loose sheets of 8½" x 11" manila-type drafting paper and tracing vellum, they allow students to cover the maximum amount of subject matter within a limited time. 1959, 72 sheets, \$3.95

Electronic Drafting

George Shiers, *Santa Barbara City College*. Interpreting and teaching industrial drafting practices, this enthusiastically received text carefully explains and thoroughly develops each topic in step-by-step procedures. A typical response from one of your colleagues was, ". . . The subject is well covered not only in the basic essentials of construction, but also in the use of graphics as well as training techniques in circuit drawing necessary in order to insure a well-laid-out plan." 1962, 556 pp., \$9.75

Electronic Drafting Tech- niques And Exercises

George Shiers, *Santa Barbara City College*. As a companion to *Electronic Drafting* or as an independent course supplement, this workbook exercises students in all phases of electronic drafting. Each exercise is carefully explained by specific instructions, initial examples, and, in many instances, sample drawings. The student's knowledge is developed in the host of details that characterize a professional drawing. 1963, 160 pp., paper, \$4.50

Basic Graphics

Warren J. Luzadder, *Purdue University*. *Basic Graphics*, the recently revised edition of *Graphics for Engineers*, is designed to fulfill today's needs of engineering and technical education. The text presents the fundamentals essential to graphical solutions and communications. Each basic concept is discussed clearly and in detail, anticipating difficulties commonly encountered by the student. Included are over eleven hundred illustrations, denoting space relationships. The book also contains problems intended to develop the student's ability to visualize space relationships and to exercise his creative ability. 1962, 720 pp., \$9.75

for approval copies, write: BOX 903

PRENTICE-HALL, Inc. Englewood Cliffs, New Jersey



THE CAUSEWAY INN
WELCOMES

The 1965 ASEE Mid-Year Meeting
of
THE ENGINEERING GRAPHICS DIVISION

Rick Diaz, Resident Manager

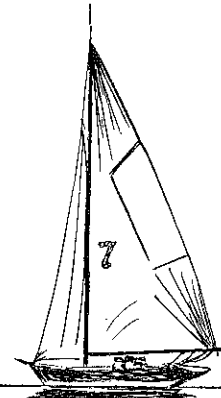

The Educational Relations Committee 1964

The Educational Relations Committee has for the past year been engaged in a study of the course content of a high school course in Technical Drawing.

The course is aimed at students planning to attend an engineering college; entitled "A Pre-Engineering Course in Technical Drawing," it assumes one year of study, five periods per week for 36 weeks, 45 minutes per period.

An evaluation of subject matter, sequence and time allotted per subject is now being determined.

When complete, the committee hopes that this outline can be published and disseminated to the secondary schools. As such it could serve as a guide for the secondary school teacher in the building and sustaining of his subject. It would produce a more uniformly prepared student for the college teacher and enable the college level of engineering graphics to move at a more rapid pace through the basic engineering drawing sequence, and explore other areas of our interest.

Robert Lang, Chairman
6-23-64

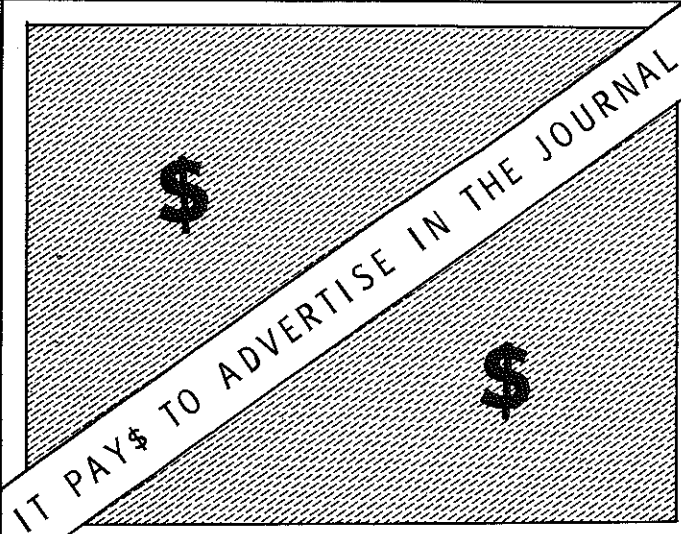

Rates for "ready for camera" ads:

\$ 40.00 per page per issue.

\$100.00 per page per year (3 issues).



For further information write:

Myron G. Mochel
Clarkson College of Technology
Potsdam, New York

4

important

books

in the field

from...

Barnes & Noble

1. Engineering Descriptive Geometry

78 Examples with Complete Solutions. 139 Problems including Answers or Suggestions. Diagrams Drawn to Scale on Cross-Section Paper.

by *Steve M. Slaby*. "The style is simple and uncomplicated. It is geared to the needs of the average college student and is well organized. Drawings are unusually clear, uncluttered, and admirable in every way. . . . It would make a welcome addition to the shelves of the high school teacher of solid geometry."--*Mathematics Teacher*

"Presenting the basic principles of descriptive geometry in clear, annotated pictorial representations followed by graphic examples."--*Science News Letter*

Paperback \$2.25

2. Engineering Drawing

Basic Principles and Rules with Problems & Tables
ASA Standard Drawings & Drafting Room Practice

by *Lombardo, Johnson, Short and Lombardo*. "The purpose of this text is to provide a comprehensive, practical guide that will aid the student to master the essentials of engineering drawing. The text is designed to introduce him to develop working skill and efficiency."--*Design News*

"Should prove useful not only to the student, but also to the engineer wishing to refresh his memory on a particular point."--*Engineering Journal*

Paperback \$2.50

Free examination copies of paperbacks are available to instructors

3. Technical Writing

A Guide to Manuals, Reports, Proposals, Articles, etc., in Industry & the Government

by *Richard W. Smith*. Written for the embryo technical writer with heavy emphasis placed on the industrial aspects of the subject giving broad application to the engineering field. It includes -- useful chapters on "The Mechanics of the Trade," a comprehensive bibliography; an appendix entitled "Are You Ready to Write" offering review examination that covers basic grammar rules and skill in expository writing, with answers and explanations.

"It's an excellent summary of the whole field, which includes many areas of technical writing that most books neglect."--*James Stokley, Michigan State University*

Cloth \$3.50; Paperback \$1.25

4. Thinking With a Pencil

With 692 Illustrations Showing Easy Ways to Make and Use Drawings in Your Work and in Your Hobbies

by *Henning Nelms*. This work begins with drawings which are so simple that they require no skill at all. Each chapter prepares the reader for the next and at the same time provides an effortless review of the material already studied. The reader learns to draw by making drawings that he can use. The formal practice required by other approaches to drawing is almost entirely eliminated.

"In my opinion your book would definitely be a valuable addition to any engineering student's library. Any medium which helps an engineer to convey his ideas to another person is without question a vital and necessary part of an engineer's education."--*Steve M. Slaby, Princeton University*

Cloth \$4.95; Paperback \$1.95

Barnes & Noble, Inc. 105 Fifth Avenue, New York 3, N.Y.



FIVE TESTED TEACHING AIDS FOR ENGINEERING DRAWING



BY CARL L. SVENSEN AND WILLIAM E. STREET

FOR USE WITH ANY TEXT OR NO TEXT

DRAFTING PROBLEM LAYOUTS

SERIES D, REVISED 1962

Work sheets covering Vertical and Inclined Lettering, Sketching, Use of Instruments, Engineering Geometry, Scales, Orthographic Projection, Revolution, Auxiliary Projection, Sections and Conventions, Isometric, Oblique, Dimensioning, Developments, Intersections, Screw Threads and Studies of Points, Lines, and Planes.

100 Work Sheets, 8 1/2" X 11" _____ \$3.50

DRAFTING PROBLEM LAYOUTS

SERIES C, REVISED 1964

Work sheets covering Vertical and Inclined Lettering, Sketching, Use of Instruments, Engineering Geometry, Scales, Orthographic Projection, Revolution, Auxiliary Projection, Sectional And Conventions, Dimensioning, Screw Threads and Bolts, Isometric, Oblique, Perspective, Developments, Intersections, Working Drawings.

95 Work Sheets, 8 1/2 " X 11 " _____ \$3.50

LETTERING EXERCISES

A DIRECT METHOD - NEW AND INTERESTING

Vertical and Inclined Lettering with eight sheets of extra problems.

20 Work Sheets, 8 1/2 " X 11 " _____ \$ 1.00

VERTICAL LETTERING EXERCISES

Vertical Lettering with instructions

6 Work Sheets, 8 1/2 " X 11 " _____ \$ 0.50

INCLINED LETTERING EXERCISES

Inclined Lettering with Instructions

6 Work Sheets, 8 1/2 " X 11 " _____ \$ 0.50

WRITE FOR EXAMINATION COPY OR ORDER FROM

W. E. STREET
ENGINEERING GRAPHICS DEPARTMENT
TEXAS A&M UNIVERSITY
P. O. BOX 188
COLLEGE STATION, TEXAS

Prepare your own problem book by selecting your drawings from these books in quantities of 25 or more of each layout.

Allow 90 days for order.

Half our sales come from replacing our competitor's dry copiers

Meet
Mr. Bruning
and his wonderful
copying machine

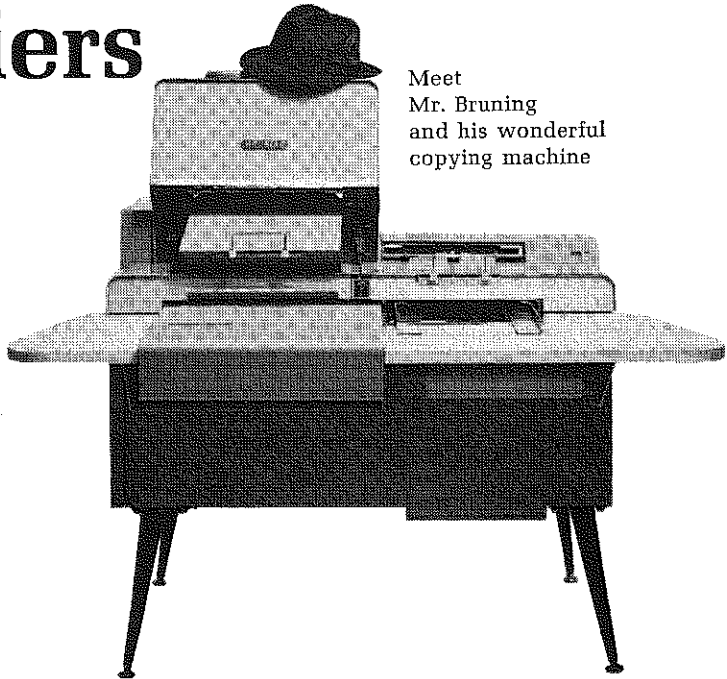

The reason: Our Bruning 2000 makes copies twice as fast, often at half the cost

These businessmen aren't fickle.

They just approach costs with a needle-sharp pencil.

So when they punch a hole in inflated office copying costs, the copier they loved and chose in May usually becomes a Bruning 2000 in December.

Reasons:

The Bruning 2000 produces sharp, top-quality copies for as little as 2½ cents each (including materials, labor and depreciation for volume purchasers). Lowest cost per copy among dry copiers.

Copies range from check size to 11 inches by any reasonable length—ledger or even roll.

It spins these copies out at 14 per minute. Because it's the fastest copier, the office help spends less time standing around waiting for copies.

And, depending on your needs, you can rent, buy or lease a Bruning 2000.

Sound tempting? The Bruning man has a 10-minute demonstration that's downright irresistible.

He's waiting in the Yellow Pages for your call.

BRUNING® / 2000

Charles Bruning Company / Division of Addressograph Multigraph Corp., Mt. Prospect, Ill.

have all the appearances of electricity. Yet in the last analysis it is simply an aspect of the physics of multiply connected space: we have before us curved empty space - and nothing more.

GEOMETRODYNAMICAL ZOO

Thus out of general relativity in the last few years has come a description of "gravitation without gravitation" - not as a magic force, but as one aspect or consequence of the curvature of space. We have also seen how to build "mass without mass" - the geon. We have a model for "electricity without electricity" - an interpretation of charge as lines of force trapped in a multiply connected space. In a similar way it is possible to talk of electromagnetism as not a separate field of force introduced into space but as a particular manifestation of the curvature of space.

What connection, if any, does this geometrodynamical zoo, this world of objects that can be built out of curved empty space and nothing more, have with the real world? The answer is we don't really know. Certainly a geon, which if it ever existed at all in nature would have had to be as large as or larger than the sun, has not the slightest connection with an elementary particle. Nor has the kind of continuous electric charge we have been talking about have anything to do with the charge of elementary particles in the real physical world. Our advances in understanding the strange world of particle physics has come through quantum mechanics. Depending on the measurement of precise, definitive values, discrete rather than continuous energy sources, the quantum seems, today at any rate, to have little to do with lines of force threaded through a multiply connected space which can have any value.

It was precisely the failure of Einstein's unified field theory to explain quantum mechanics that prompted him to make his later attempts to introduce an artificial kind of geometry into his view of space and time. And yet the theory of general relativity today seems to be what I have called an already unified field theory, a set of ideas to which quantum mechanics may be added rather than a view from which it may be deduced. Indeed, to my mind, one of the most important and challenging problems for the future of physics is just this: adding the quantum to geometrodynamics.

What would be the consequences of a quantized picture of space? What view of the universe could be expected to emerge from such an endeavor? At this point theory breaks down almost completely and one can only speculate. We have noted above the extreme difficulties of exploring space down to the very small distances of 10^{-33} centimeters, but it is evident that, following the line of geometrodynamical theory, that at these distances quantum action would force on space a fluctuating character. At these tiny distances, one can speculate that an appropriate

view of space might be of its being foam-like in structure.

We are all familiar with the action of a wave, which in breaking smashes part of the water through which it is travelling into tiny bubbles. This foam persists for a while after the wave passes, then subsides until another wave comes along to repeat the process. Perhaps a picture of this sort could also apply to the three-dimensional space of the universe. At first we would have nothing but curved empty space. Then, a disturbing wave would appear, emanating perhaps from the energy associated with the curvature itself. This wave, building up as does a wave in water, would crush the space into the foam-like structure just spoken of. The "bubbles" thus produced would therefore coincide with our topological "wormholes," providing the highly multiply connected space in which the model of electricity we have discussed could play its part.

". . . THIS WONDERFUL BELIEF"

While at first glance, thinking of space as having a complex structure, as multiply connected, or foam-like in structure, seems very foreign to the normal view, there are in fact many points of connection between this view and the view modern physics has forced us to accept. A central part of quantum electrodynamics is the view that electrons, both positive and negative, are continually being created and annihilated not only in the neighborhood of elementary particles, but throughout all space. We can see that a convenient way of looking at this phenomenon would be to regard it not as the sudden appearance and disappearance of charged particles, but as the observable effect of continuous charge trapped in the multiply connected structures of space.

It is highly dubious that anything "practical" will ever come out of this kind of physical research. Although one has not the slightest right to rule out the discovery, sometime in the distant future, of an entirely new kind of energy source. For if anything at all is clear in the picture of gravitation physics today, it is that we are dealing with a source of matter itself; we are, in theory at least, talking about the possibility of converting, not a fraction of one per cent of the energy of mass, but all of the energy in each kilo of mass into usable form. The fact that there is not today the slightest hint as to how this might come about, still does not mean that anyone can rule it out completely.

Physicists remain interested despite the lack of apparent practicality, and our enquiries are still couched rather in the spirit of Einstein, who said: "All of these endeavors are based on the belief that existence should have a completely harmonious structure. Today we have less ground than ever before for allowing ourselves to be forced away from this wonderful belief."



*Reflecting the need for a broader
understanding of a powerful design tool*

ENGINEERING GRAPHICS

For Design and Analysis

ROBERT H. HAMMOND, *United States Military Academy*
CARSON P. BUCK, *Syracuse University*
WILLIAM B. ROGERS, *United States Military Academy*
GERALD W. WALSH, Jr., *Jefferson Community College*
HUGH P. ACKERT, *University of Notre Dame*

THIS CLASS-TESTED TEXT BOOK reflects the growing need for a broad comprehension of graphics as a powerful tool in the design process. Its prime purpose is to provide the student with a complete understanding of the role the graphic language plays in the conception, analysis, and communication of ideas. At the same time, the book presents sufficient material to enable the student to understand basic production drawings and to provide the background for the understanding of more complex drawings.

Emphasis is on the theory of projection and on analysis rather than on the techniques and skills required in preparing a production drawing. The development of skill is emphasized as it affects the concepts of accuracy in the use of graphics for analysis. Spatial relationships required for the analysis of three-dimensional problems are presented so that the student can develop his own solution for any particular problem. Numerous step-by-step illustrations supplement the text, and no concept is applied until its theory has been developed for the general case.

A wide range of student problems offer abundant exercises in both representation and analysis. 1964. 532 pp., illus. \$9.50

CONTENTS: Introduction. **Equipment and Techniques:** Drawing with Instruments. Sketching. Lettering. **Projection Drawing:** Projection Theory. Orthographic View Construction. Conventions in Drawing. Pictorial Representation. **Spatial Analysis:** Basic Spatial Relations. Angular Spatial Relations. Special Problems Involving Spatial Relations. Vector Geometry. Intersections and Develop-

ments. **Graphical Mathematics:** Graphs and Diagrams. Graphical Arithmetic and Algebra. Graphical Calculus. Nomographs—Graphic Analog Computers. Empirical Equations. **Applications:** Drawings for Design and Production. Additional Applications. **Appendices:** Mathematical tables; bolt and nut sizes; tables of screw, washer, key, and taper pin sizes.

The Ronald Press Company.....

.....15 East 26th Street / New York, N.Y.

THE CLARKSON/OSWEGO STATE PROGRAM

FOR UPGRADING HIGH SCHOOL MECHANICAL DRAWING COURSES

College faculty members can encourage high schools to upgrade their mechanical drawing courses to pre-engineering courses for college bound seniors.

SUCH COURSES MIGHT INCLUDE TOPICS FROM THE LIST BELOW:

- Principal orthographic reference planes.
- Auxiliary orthographic reference planes.
- Orthographic lines and planes.
- Developments.
- Freehand sketching.
- Isometric drawings.
- Oblique drawings.
- Detail drawings.
- Sectioning.
- Dimensioning.
- Manufacturing processes.
- Logarithmic and linear scales.
- Making linear graphs.
- Making semi-logarithmic graphs with a uniform abscissa.
- Making semi-logarithmic graphs with a logarithmic abscissa.
- Making full logarithmic graphs.
- The slide rule.
- Applications of logarithms.
- The vernier.
- Orientation to science.
- Orientation to engineering.

Such topics as care of instruments, lettering and geometric constructions are considered by-products of the above.

■ **FOR FURTHER INFORMATION** and details of the program, please contact Dr. William Huss, State University College, Oswego, New York or Professor Myron G. Mochel, Clarkson College of Technology, Potsdam, New York.

COURTESY OF THE GENERAL ELECTRIC COMPANY

BRADDOCK LETTERING ANGLES

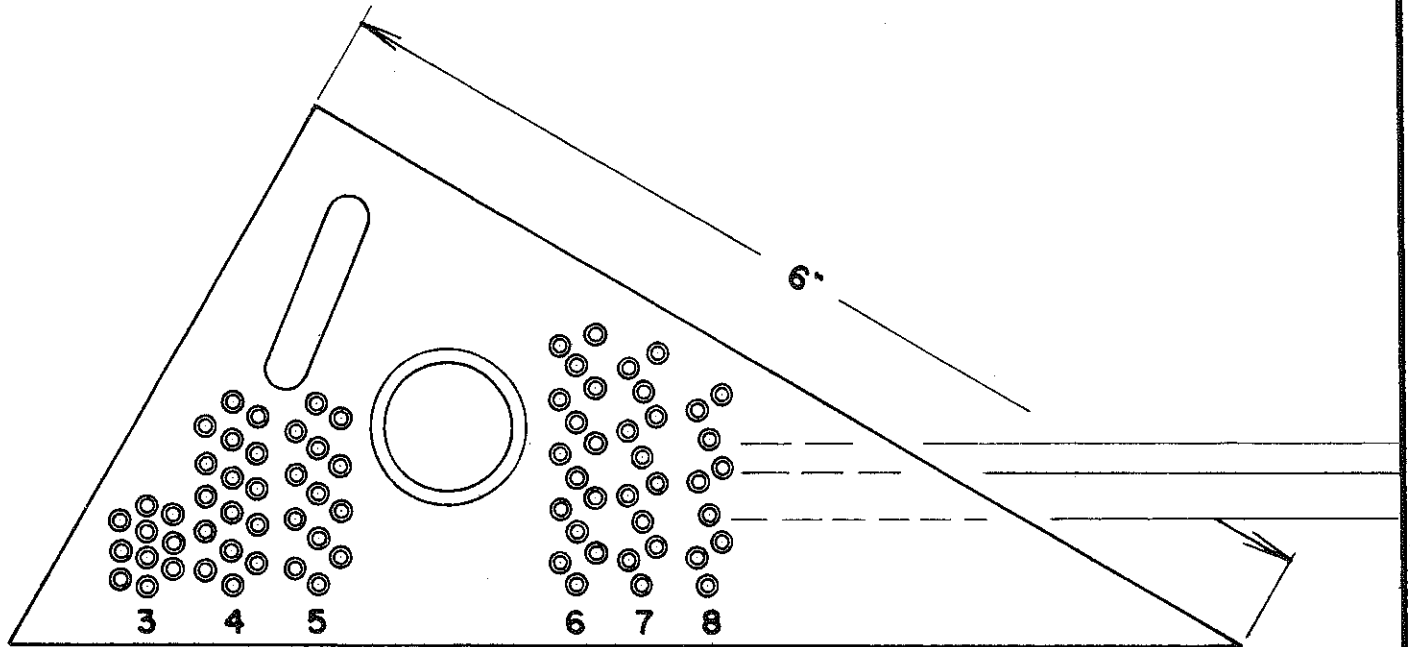

Style "A"

- 5"-60
- 6"-60
- 7"-60
- 8"-60
- 9"-60
- 4"-45
- 5"-45
- 6"-45
- 7"-45
- 8"-45
- 6"-45 Brd.-Rowe
- 8"-45 Style "C"

These combination lettering guides and triangles make it easy and simple to draw accurately spaced guide lines for lettering uniformly spaced parallel lines and systematic dimensioning.

8"-45 Style "B" Brd.-Rowe

Style "B"

- 5"-60
- 6"-60
- 7"-60
- 8"-60
- 9"-60
- 4"-45
- 5"-45
- 6"-45
- 7"-45
- 8"-45
- 6"-45 Brd.-Rowe
- Lettering Device

CLEAR - TRANSPARENT - FLAT - NON-INFLAMMABLE - DIMENSIONNALLY STABLE

FOR FRESHMAN ENGINEERING STUDENTS and PROFESSIONAL DRAFTSMEN & DESIGNERS

BRADDOCK INSTRUMENT COMPANY

PITTSBURGH 18, PA.

McGRAW-HILL ANNOUNCES THE ESTABLISHMENT OF THE

ENGINEERING GRAPHICS MONOGRAPH SERIES

UNDER THE COORDINATING EDITORSHIP OF
STEVE M. SLABY, PRINCETON UNIVERSITY

a paperback series of technical monographs designed to make readily available to students and educators new and challenging concepts in the field of engineering graphics

This series evolved from the ENGINEERING GRAPHICS COURSE CONTENT DEVELOPMENT STUDY, a project supported by leading educators in the field. The books are designed to provide supplementary instructional material that will help enrich the educational experience of engineering students enrolled in graphics or design courses. Through a consideration of modern engineering topics, these books are intended to give to students a broader perspective and a better appreciation of the versatility and usefulness of graphics. The authors and the editorial committee have made a conscious effort to include only material that does not appear in standard textbooks. The first seven books in the series will soon be available. Other pertinent topics are being investigated for probable development and publication.

GRAPHICS IN SPACE FLIGHT

By FRANK A. HEACOCK, Princeton University.

114 pages, \$4.50 (cloth), \$2.50 (soft cover).

GRAPHIC PROBLEMS FOR NUMERICAL CONTROL

By ROBERT B. THORNHILL, Wayne State University

ENGINEERING GRAPHICS IN CONCEPTUAL DESIGN

By STEVEN COONS, Massachusetts Institute of Technology; and
MATTHEW McNEARY, University of Maine

GRAPHIC APPROACH TO ANALOG SIMULATION

By JAMES R. BURNETT, Michigan State University; and EARL C. ZULAUF,
University of Detroit

GRAPHICAL COMPUTER INPUT OF DESIGN CONCEPTS

By STEVEN COONS, Massachusetts Institute of Technology

NEW METHODS OF GRAPHICAL COMMUNICATION

By LEWIS G. PALMER, University of Minnesota

COMPUTER GRAPHICS IN COMMUNICATION

By WILLIAM A. FETTER, The Boeing Company, Wichita, Kansas

Textbooks, manuals and problem books in Engineering Graphics...

ENGINEERING DRAWING

A MANUAL OF ENGINEERING DRAWING FOR STUDENTS AND DRAFTSMEN, *Ninth Edition*

By THOMAS E. FRENCH and CHARLES J. VIERCK. 593 pages, \$8.95.

FUNDAMENTALS OF ENGINEERING DRAWING

By THOMAS E. FRENCH and CHARLES J. VIERCK. 522 pages, \$7.50.

ENGINEERING DRAWING, *Second Edition*

By FRANK ZOZZORA. 391 pages, \$7.75.

ENGINEERING DRAWING. Combined Textbook and Workbook

By HIRAM E. GRANT. 192 pages, \$9.75.

ENGINEERING DRAWING PROBLEMS BOOKS

ENGINEERING DRAWING PROBLEMS

By CHARLES J. VIERCK and RICHARD HANG (to be used with A MANUAL OF ENGINEERING DRAWING FOR STUDENTS AND DRAFTSMEN, by French and Vierck). 109 pages, \$5.50.

FUNDAMENTAL ENGINEERING DRAWING PROBLEMS

By CHARLES J. VIERCK and RICHARD HANG (to be used with FUNDAMENTALS OF ENGINEERING DRAWING, by French and Vierck). 78 pages, \$4.50.

ENGINEERING DRAWING PROBLEMS, *Second Edition*

By FRANK ZOZZORA (to be used with ENGINEERING DRAWING, *Second Edition*, By Zozzora). 192 pages, \$4.75.

ENGINEERING DRAWING PROBLEMS, *Series I*

By HIRAM E. GRANT. 60 sheets, \$5.50.

PROBLEMS IN ENGINEERING DRAWING, *Series V*

By A. S. LEVENS and A. E. EDSTROM. 136 pages, \$5.50.

ENGINEERING AND ARCHITECTURAL LETTERING

By HIRAM E. GRANT, 192 pages, \$1.50.

ENGINEERING DRAWING BASIC PROBLEMS, *Series A*

By VIERCK, COOPER and MACHOVINA, 72 pages, \$4.50.

CREATIVE PROBLEMS FOR BASIC ENGINEERING DRAWING

By MATTHEW McNEARY, ELIZABETH A. KELSO, and ERNEST R. WEIDHAAS. 52 pages, \$4.95.

ENGINEERING GRAPHICS

GRAPHIC SCIENCE: Engineering Drawing, Descriptive Geometry, Graphic Solutions, *Second Edition*

By THOMAS E. FRENCH and CHARLES J. VIERCK. 718 pages, \$9.50.

GRAPHICS

By JOHN T. HULE and STEVEN A. COONS. 484 pages, \$8.95.

A MANUAL OF ENGINEERING GEOMETRY AND GRAPHICS FOR STUDENTS AND DRAFTSMEN

By HOLLIE W. SHUPE and PAUL A. MACHOVINA. 359 pages, \$6.50.

GRAPHICS PROBLEMS BOOKS

CREATIVE PROBLEMS IN ENGINEERING GRAPHICS

By ERNEST R. WEIDHAAS. 290 pages, \$4.95.

CREATIVE PROBLEMS IN ENGINEERING GRAPHICS, *Alternate Edition*

By ERNEST R. WEIDHAAS.

120 pages, \$5.95.

PROBLEMS IN GRAPHICAL ANALYSIS

By PERCY H. HILL. 162 pages, \$5.50.

GRAPHIC SCIENCE PROBLEMS, *Second Edition*

By CHARLES J. VIERCK and RICHARD I. HANG. 334 pages, \$5.95.

DESCRIPTIVE GEOMETRY

APPLIED DESCRIPTIVE GEOMETRY, *Fifth Edition*

By FRANK M. WARNER and MATTHEW McNEARY. 256 pages, \$5.95.

TECHNICAL DESCRIPTIVE GEOMETRY, *Second Edition*

By B. LEIGHTON WELLMAN. 640 pages, \$6.95.

PRACTICAL DESCRIPTIVE GEOMETRY, *Without Problems*

By HIRAM E. GRANT. 253 pages, \$5.50.

DESCRIPTIVE GEOMETRY PROBLEMS

PRACTICAL DESCRIPTIVE GEOMETRY PROBLEMS, *Second Edition*

By HIRAM E. GRANT. 72 sheets, \$4.95.

PROBLEMS IN APPLIED DESCRIPTIVE GEOMETRY

By MATTHEW McNEARY (to be used with APPLIED DESCRIPTIVE GEOMETRY, by Warner and McNeary). 136 pages, \$4.25.



RESERVE YOUR ON APPROVAL COPIES NOW

McGraw-Hill Book Company

330 WEST 42nd STREET / NEW YORK, N. Y. 10036

Dieffler
Gramercy

Frank Oppenheimer

GRAMERCY GUILD GROUP INC.

WE WILL CONTINUE TO SERVE
THE EDUCATIONAL FIELD,
AS WE HAVE DONE
FOR THE PAST EIGHTEEN YEARS,
WITH NEW DESIGNS
IN DRAWING INSTRUMENTS.

THIS YEAR WE INTRODUCED
THE NEW "RIEFLER R" LINE
WITH THE REVOLUTIONARY
QUICK-ACTION BOW.

THESE FINE INSTRUMENTS
ARE AVAILABLE
IN MANY COMBINATIONS.

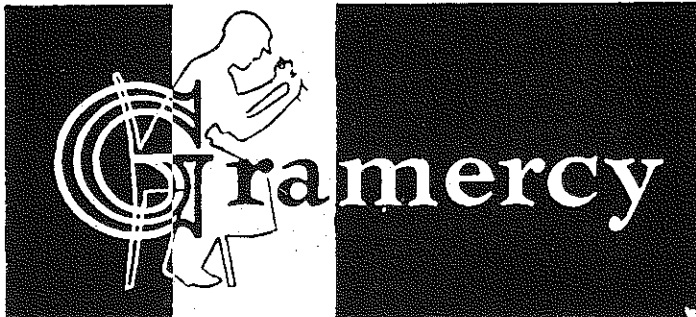

this

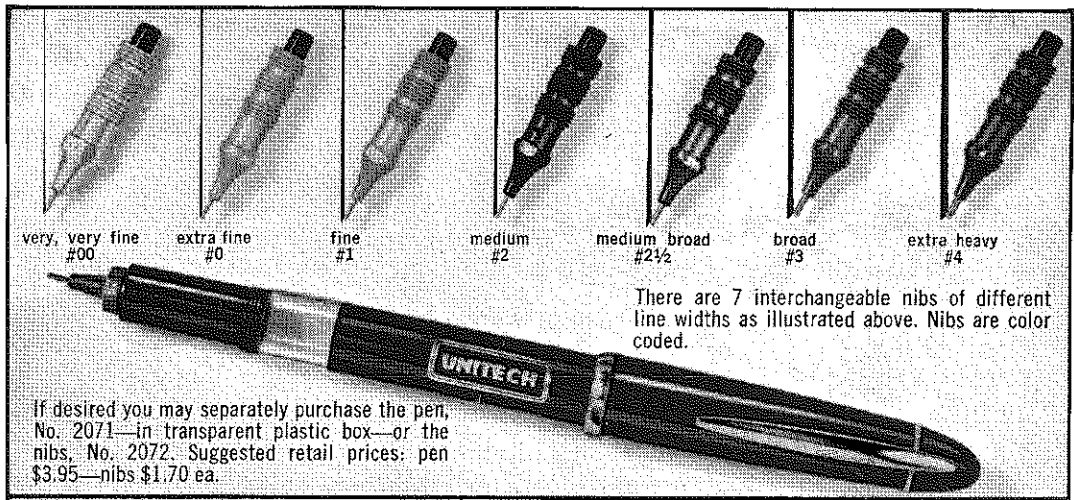

+this



=perfect

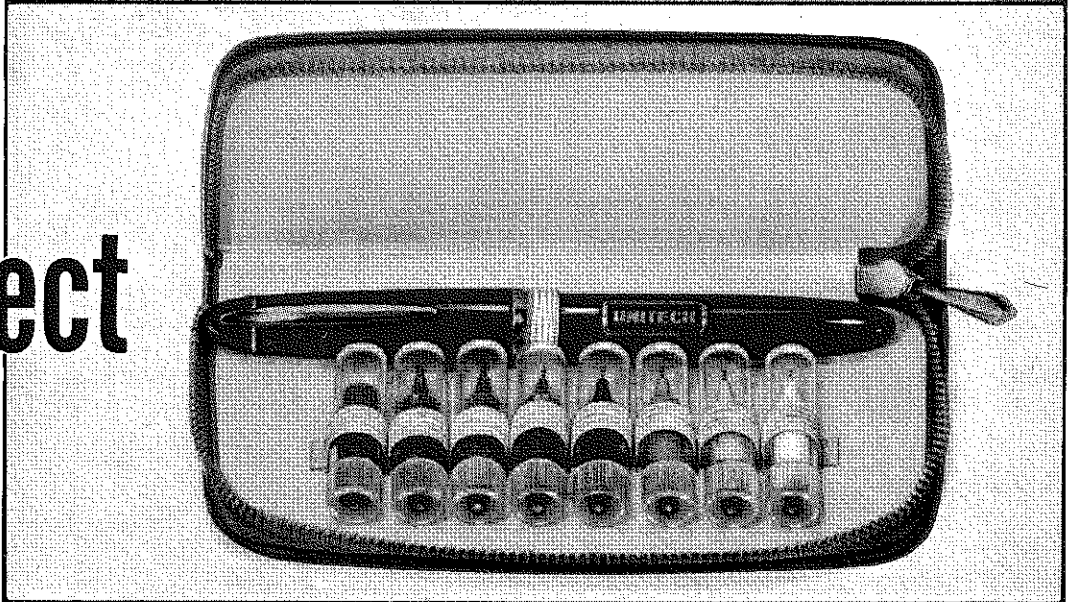

Look again. Could anything be more practical, more convenient or more carryable in the pocket. Gift set is handsomely cased in genuine leather. The 'Unitech' technical fountain pen is a true precision instrument, proven for years. Visible ink supply, airtight filling system, needle point which detaches for cleaning—you name the feature, 'Unitech' has it. Uses India ink or regular ink. Send for literature or see at dealer. Actual size under 3" x 6". Complete leather-cased set, No. 2073, suggested retail \$14.95.

Charvoz-Roos Corp.

50 COLFAX AVE., CLIFTON, NEW JERSEY

A COMPLETE LINE FOR ARCHITECTS AND DRAFTSMEN