

# The Journal of Engineering Drawing

## CONTENTS

	Page
THE EFFECT OF TRAINING ON THE SPATIAL VISUALIZING ABILITY OF ENGINEERING STUDENTS, by R. H. Woodcock, University of Wisconsin .....	7
ENGINEERING DRAWING: DYNAMICS OR STATICS, by J. E. Snyler, Clemson College .....	13
ANNOUNCEMENTS .....	14
CHART DISTORTION IN THE CONSTRUCTION OF NOMOGRAMS, by Clude H. Sparks, Ohio State University .....	18
PERSONALITY SKETCH OF PROFESSOR WILLIAM W. TURNER, by C. F. Buck, University of Notre Dame .....	20
GRAPHICS IN AN EXPANDING SCIENTIFIC AGE, by A. S. Lorenz, University of California .....	24
A BRIEF SURVEY OF GRAPHIC REPRODUCTION PROCESSES, by H. P. Sawyer and E. L. Foss, Michigan State College .....	32

VOL. 12, No. 1

FEBRUARY, 1935

SERIES No. 15

PUBLISHED BY THE DIVISION OF ENGINEERING DRAWING AND DESCRIPTIVE GEOMETRY  
OF THE AMERICAN SOCIETY FOR ENGINEERING EDUCATION

I HOPE THAT THIS  
WILL ARRIVE SOON ENOUGH  
FOR ME TO RECEIVE  
THE NEXT ISSUE!

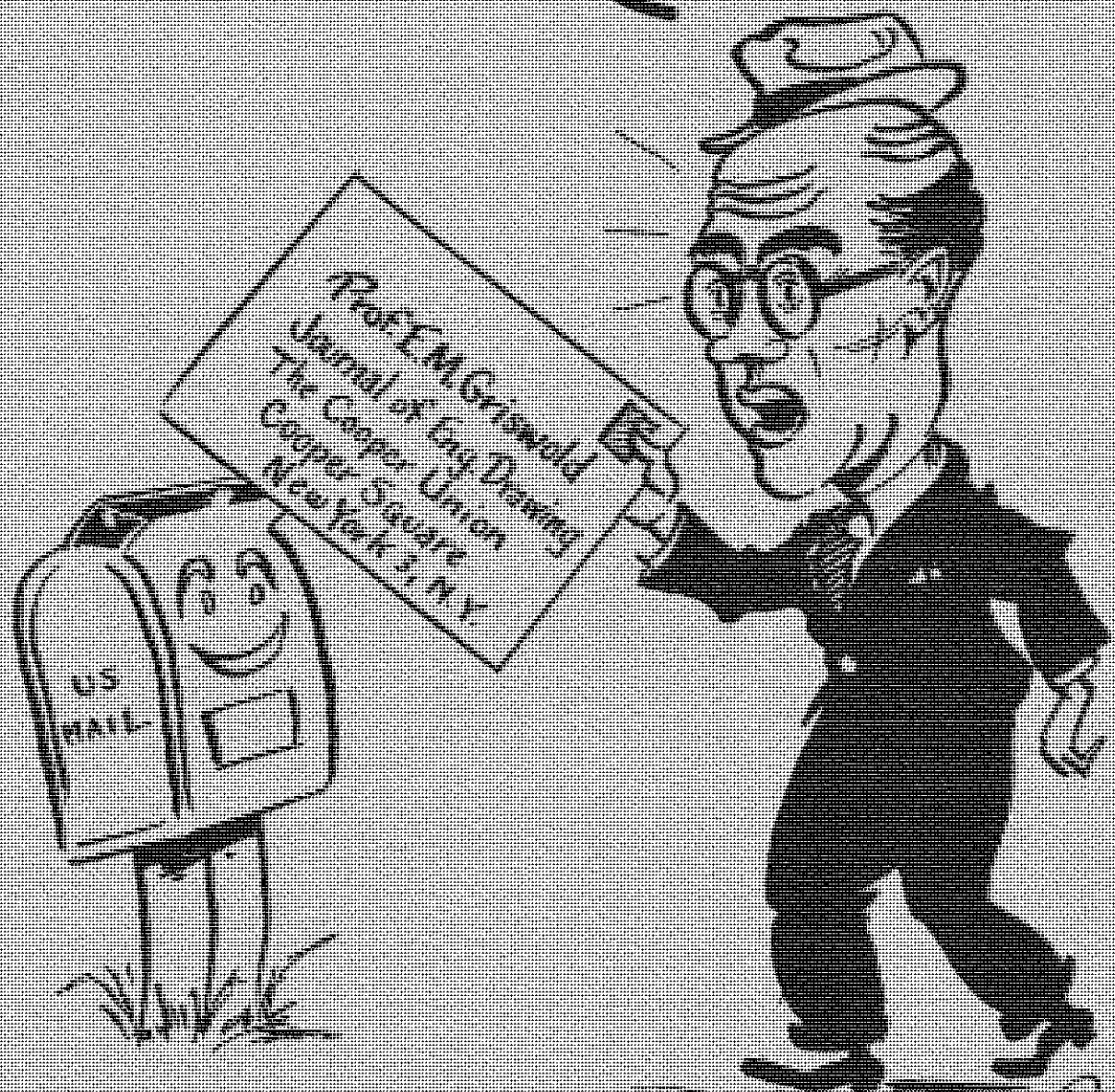

Dick Cavett  
1964



# BRADDOCK LETTERING ANGLES

DESIGNED FOR STUDENTS, ENGINEERS,  
DRAFTSMEN AND ARCHITECTS

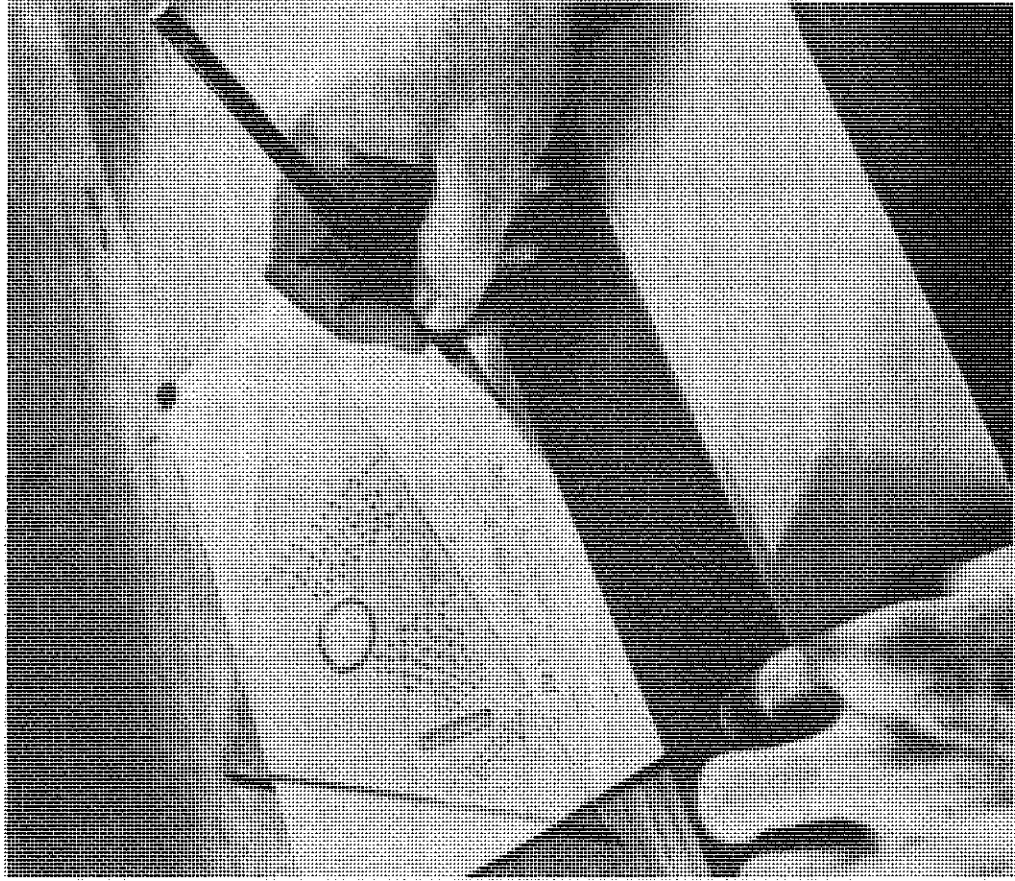
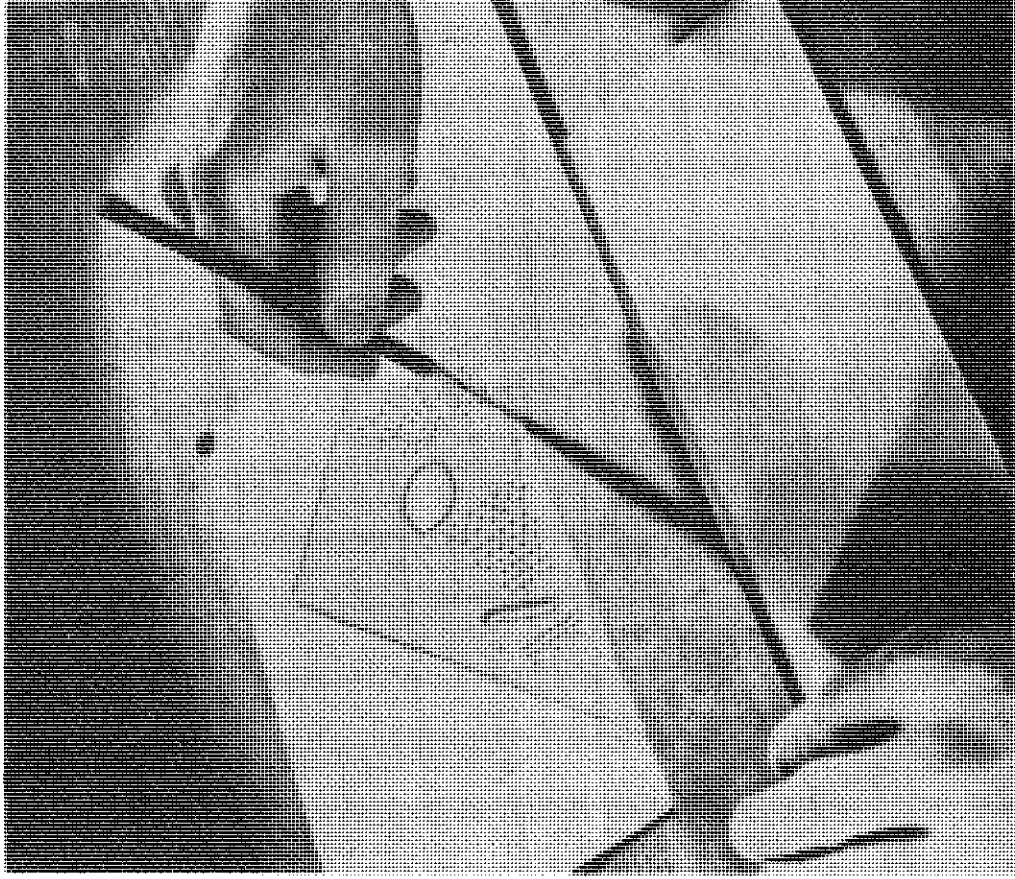

## BRADDOCK ROWE LETTERING ANGLE

The special group of holes "S" on the BRADDOCK ROWE LETTERING ANGLE was designed primarily to aid in teaching SYSTEMATIC DIMENSIONING by giving a QUICK and EASY method of properly locating dimensions and drawing guide lines for them. They are located where they are most convenient to use, low in the lower left corner. This instrument also serves as a 6 inch 45 degree standard drafting triangle. It is made of dimensionally-stable VINYLITE, and is of exceptional accuracy. Braddock Lettering Angles are available in twenty-two other sizes and styles in the 30-60 and 45 degree shapes. All are made of VINYLITE.

## BRADDOCK INSTRUMENT COMPANY

PITTSBURGH 18, PA.

# OUTSTANDING AIDS

*For Engineering Drawing Students*

*from McGraw-Hill*

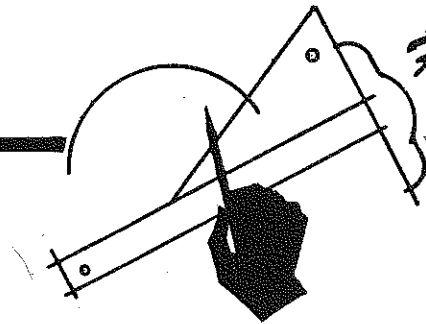

—Send for copies on approval—

## Graphic Aids In Engineering Computation

By RANDOLPH P. HOELSCHER, University of Illinois; J. NORMAN ARNOLD, Purdue University; and S. H. PIERCE, University of Illinois. 194 pages, \$4.50

A text designed for courses covering the principles and methods of the slide rule and the construction of alignment charts. It covers a number of graphical and mechanical methods of computation not heretofore assembled in one text. There are chapters on the standard slide rules, the derivation of empirical equations from laboratory or field data, the construction of nomographs by geometric methods and with determinants, the construction of special slide rules, the solutions of problems by graphical differentiation and integration, and advanced work on movable scale charts.

## Industrial Production Illustration

For Students, Draftsmen, and Illustrators

Second Edition

Edited by RANDOLPH P. HOELSCHER, CLIFFORD H. SPRINGER, University of Illinois, and RICHARD F. POHLE. 243 pages, \$6.50

Here is an excellent text for courses in production illustration and for courses in industrial training schools. It covers the entire range of pictorial drawing, from both the theoretical and practical points of view, for those who wish to do production illustration in the aircraft, shipbuilding, ordnance, automotive, or other industrial fields. The three forms of pictorial representation are clearly covered, and the book gives full theory and method for use in drawing with instruments. Also, the book shows how to employ short cuts, free-hand sketching, and enough material on shading to enable the draftsman to give life to his work. Throughout the book, all procedures are carefully explained and illustrated by breakdown sketches.

## Industrial Design

A Practical Guide to Product Design and Development  
Second Edition

By HAROLD VAN DOREN. 392 pages, 283 illustrations, \$6.50

In a simple, non-technical manner, this practical handbook describes the principles, techniques, and procedures for preparing mass produced, three-dimensional products for market, from preliminary research to final prototypes and consumer testing. This completely revised edition, containing a wealth of illustrations, covers such topics as design planning, basic elements of three-dimensional design, rendering, and model making.

## Applied Descriptive Geometry

With Drafting-Room Problems

New Fourth Edition

By FRANK M. WARNER, University of Washington. 247 pages, 212 illustrations, \$4.00

Application is the keynote of this text designed to teach clearly and simply, by the direct method, the few fundamental principles of descriptive geometry. The book presents a large collection of problems with engineering data and terms so as to give the student considerable practice in applying the principles in solving a large variety of engineering problems. Many of the problems have been taken directly from some commercial job. In the fourth edition new materials have been added, problems have been revised, and new illustrations included.

## Applied Descriptive Geometry Problem Book

Second Edition

By FRANK W. WARNER and CLARENCE E. DOUGLASS, University of Washington. 63 pages, \$3.75

A thorough revision of the widely used problem book correlated with the new fourth edition of Warner's *Applied Descriptive Geometry*. The problem manual saves the student time in layout work, thus enabling the completion of more problems. The manual also encourages the use of more problems with an engineering framework by partially setting them up for solution. The book covers all the point-line-plane principles and most of the curved surface principles needed in engineering practice.

**McGraw-Hill Book Company, Inc.**

330 West 42nd Street

New York 36, N. Y.

## DESCRIPTIVE GEOMETRY

A Pictorial Approach

HAROLD BARTLETT HOWE

*Rensselaer Polytechnic Institute*

THIS TEXTBOOK, combining the pictorial approach with the direct method, provides a clear-cut way to present descriptive geometry. The method used stimulates student capacity to perceive and visualize; facilitates mastery of principles; and insures a broad coverage of the subject. The ability to sketch is gradually built up by progressing from simple fundamentals to more complicated combinations. Special emphasis is placed on vectors and their use in finding stresses in planar and non-coplanar structures and for the representation of moments. Throughout the text, theories are applied to the solution of practical problems. All projects are complete with drawings and explanations, on single or facing pages. "Well written—covers the subject in a very satisfactory manner."—C. H. SPRINGER, University of Illinois.

328 ills.

332 pages

## Problems for DESCRIPTIVE GEOMETRY

also by

HAROLD BARTLETT HOWE

THIS PRACTICAL WORKBOOK, containing a wide selection of theoretical and applied problems drawn from engineering situations, provides a valuable supplement to Howe's outstanding textbook. The pictorial approach used throughout stimulates student interest, and gives a firmer, quicker grasp of fundamentals. The liberal use of sketches helps him see and record space relationships and arrangements as preparatory steps to orthographic rendering. Includes 77 layout and illustration sheets, 9 $\frac{1}{8}$  x 11 with directions for student use.

• Note also the following books on engineering and architectural drawing, all by WILLIAM WIRT TURNER, University of Notre Dame.

### Basic Problems in Engineering Drawing

Series of engineering drawing work sheets based on third-angle projection. In line with trend toward coordinated courses in engineering drawing and descriptive geometry. Use with any standard textbook. 112 sheets, 8 $\frac{1}{2}$  x 11; 74 sheets of problem layouts and illustrations. Revised Edition.

### Freehand Sketching for Engineers

Prepared to develop sketching ability of students and engineers; teach theory underlying engineering drawing; and train students in reading drawings. Based on latest revised American Standard practices. 97 sheets, 8 $\frac{1}{2}$  x 11; 55 sheets of problem layouts and illustrations.

## BASIC ENGINEERING DRAWING

WILLIAM WIRT TURNER, CARSON P. BUCK,

and HUGH P. ACKERT

—all of the University of Notre Dame

INTRODUCES students to all the basic principles of engineering drawing, descriptive geometry, and machine drawing. Written to fill a widely recognized need for a course integrating these subjects, it is at the same time flexible enough to be used by instructors whose teaching needs cover only one of these fields. The presentation of all three phases of engineering drawing assumes no previous knowledge of the subject on the part of the student. Chapters devoted to machine drawing are concerned with the application of drawing theory and practice, in keeping with the latest recommendations of the American Standards Association. The treatment of pictorial drawing is comprehensive and contains many innovations. "Well organized, well illustrated, well written."—W. A. WOLFE, University of British Columbia.

563 ills.

26 tables

669 pages

## Integrated Problems in Engineering Drawing and Descriptive Geometry

WILLIAM WIRT TURNER

SPECIFICALLY DESIGNED for use with Basic Engineering Drawing is this series of explicit, detailed problems covering the fundamentals of the three integrated fields. From the outset, simple orthographic projection is regarded from the point of view of descriptive geometry. Basic theory is first presented, followed by the various phases of drawing in their natural sequence. Contains 83 problem layouts and 16 practice sheets, 8 $\frac{1}{2}$  x 11, with clear instructions.

### Projection Drawing for Architects

For architectural students who must obtain, in shortest possible time, a mastery of fundamentals of projection drawing. Appropriate for engineering courses where a thorough training in basics of engineering drawing and descriptive geometry is considered adequate. 107 pages, 6 x 9; 55 illustrations.

### Shades and Shadows

—Their Use in Architectural Rendering.

Clear, comprehensible information for correctly determining the shades and shadows of objects, particularly architectural compositions. The methods most commonly used are explained and illustrated in detail. 115 pages, 6 x 9; 95 illustrations. Work sheets, 13 x 17.

### Simplified Perspective

Textbook on theory and practice of perspective drawing. Meets working needs of architectural and engineering classes, practitioners. Equips user to make architectural, mechanical, production drawings such as the exploded views used in manufacturing. 236 pages, 6 x 9; 93 figures; 5 illustrations.

# LIFE'S MESSY MOMENT

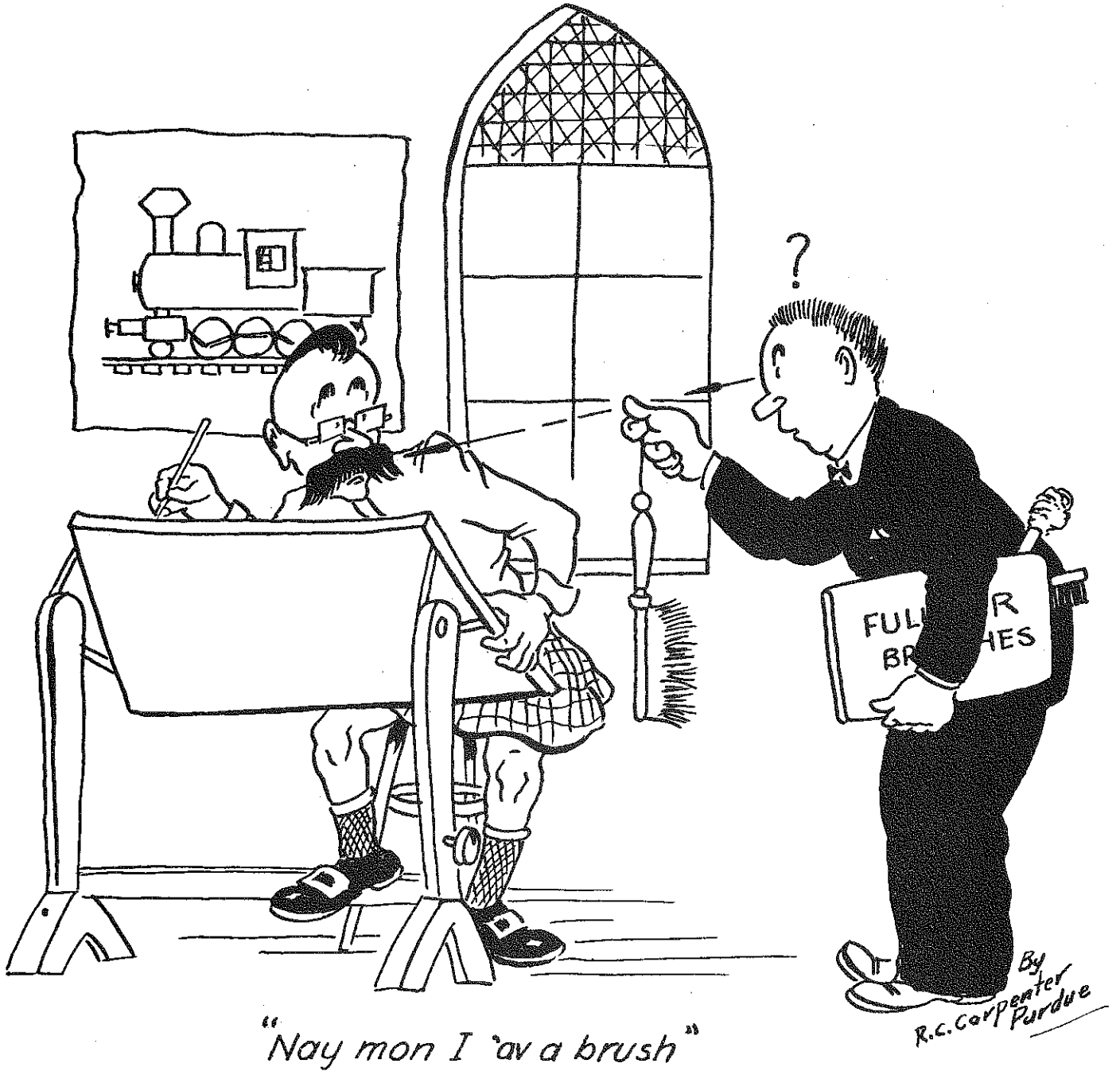

JOHN S. SWIFT CO., INC.

*Planographers*

has released their advertising space in this issue to the editor that he may present a special feature. We invite your consideration of our unique and complete facilities for your printing requirements in the Educational Field.

OPERATING PLANTS IN ST. LOUIS - CHICAGO - NEW YORK - CINCINNATI - CLEVELAND  
2100 LOCUST STREET • SAINT LOUIS 3, MO.  
Telephone CHestnut 1-7140

THE EFFECT OF TRAINING ON THE SPATIAL VISUALIZING ABILITY OF ENGINEERING STUDENTS\*

by  
Professor R. R. Worsencroft  
University of Wisconsin

1. **INTRODUCTION** - The trait of visualization is defined by Webster's Unabridged Dictionary as "The act or power of forming visual images, or mental representations of objects not present to the senses." Spatial visualization is the forming of these images in terms of three dimensions; in short, of visualizing physical entities. This trait is considered as one of the most important of those intangible faculties that all engineers should possess in some amount. From the degree of its development during the course of his college work may stem the engineer's ability to apply his basic theory more or less successfully to practical situations. Spatial visualization is recognized as an essential ingredient in every field of design, and is extremely useful in the process of planning and executing any engineering project.

No specific course in the engineering curriculum is charged with the development of this trait, as, for example, heat-power courses are charged with the development of thermodynamic theory. Where, then, does it occur, for the accomplishments of our graduates indicate that such a development does take place to a greater or less degree. For this reason it was felt that a study of the development of this trait in engineering students, and a determination of the factors which caused it would prove of value.

2. **OBJECT OF THE STUDY** - Accordingly, this study of spatial visualization has been undertaken (1) to determine the incidence of this trait in engineering matriculates, and whether they possess it, as a group, to a markedly greater degree than other University matriculates; (2) to evaluate statistically the amount and significance of the improvement in the trait during the freshman year in engineering, as against the general freshman year; and (3) to determine any study experiences responsible for its development.

3. **METHOD OF PROCEDURE** - The value of the study depended largely upon the accuracy with which the trait could be evaluated, and its development determined over the period in which it was studied. To make the initial evaluation, a suitable test was selected and administered to an engineering group consisting of the entering freshman class of 1950. As a control group, a random sample of Letters & Science male freshmen were given the same test. To determine the development over the period of the freshman year, the same test was administered to the same groups at the close of the year. The analysis of the scores on these tests, using the Letters & Science group as a control factor, made possible a fairly accurate evaluation of the development of the trait due to (1) maturation, and (2) differences in study experiences. Members of the engineering group were then paired with members of the L & S group on the basis of the scores in the first test, and an even more accurate measure of development was thus obtained. A statistical analysis of these scores against the background of scholastic data on study experience forms the basis for the results and conclusions of the study.

4. **SELECTION OF A SUITABLE TEST** - The test used for evaluation of the trait was Spatial Relations Test VAC1 (Form YCU) designed and distributed by the Educational Testing Service, Princeton, N.J. It was selected for several reasons.

a. The test involves visualizing forms in three dimensional relationships (spatial) rather than the more

customary two dimensions (planar). It is so constructed that a visual image of some shape or form shown in pictorial, must be formed before each question can be answered. It does not depend upon any previous technical knowledge the examinee may have in the field of graphics. The test has been used for a number of years by the College Entrance Examination Board to test spatial relations ability, and according to the Educational Testing Service "this test is one useful measure of spatial relations ability."<sup>1</sup>

b. Since the test was to be repeated, it was felt that it should contain enough items so that those making comparatively high scores the first time would have material upon which to improve their scores the second time. This test contained 90 items, with 60 minutes allowed for completion.

c. It is a test of the objective type, and conventional multiple choice form familiar to most high school students. It can be scored with a minimum of error.

d. The same test has been used previously in a somewhat similar study at Cooper Union<sup>2</sup> and at West Point,<sup>3</sup> and it was thought that it might be advisable to correlate the results of all of these studies at some future time.

5. **ADMINISTRATION OF THE TEST** - The first testing (September, 1950) was administered during Freshman Week to both engineers and L & S students by the Student Counseling Service of the University, as group tests. After Freshman Week, it was no longer possible to get either group together as a unit. Therefore, the second testing (May, 1951) was administered to the engineers in their several drawing classes by the instructors of those classes, and on consecutive hours as the classes met. The L & S students were given the test individually in the testing laboratory of the Student Counseling Service, where they came by appointment. Due to transfers, withdrawals, dropping of courses, and the voluntary nature of the second testing with respect to the L & S group, the number taking both tests was considerably smaller than the number taking the first step only. These numbers are indicated in Fig. 1.

FIGURE 1. NUMBER OF STUDENTS TESTED

GROUP	1st Test	Both Tests
Engineers	172	114
L & S Students	234	124

6. **OTHER DATA SECURED** - Considerable additional and pertinent scholastic data was collected on all of the students taking both tests. Such of this data as has been used will be introduced and identified at that point in the study where it is used.

7. **ANALYSIS OF FIRST TESTING** - The incidence of the trait of spatial visualization as measured in the two groups of matriculates was determined from the first testing. The analysis of the scores is given at this point, and includes all the students of both groups.

\* Project D1 - Engineering Experiment station - University of Wisconsin.

<sup>1</sup> Letter of May 23, 1952, from Educational Testing Service expressing their views on this point.

<sup>2</sup> See Research Bulletin RB-51-6 by C. T. Meyers (Educational Testing Service)

<sup>3</sup> Ibid.

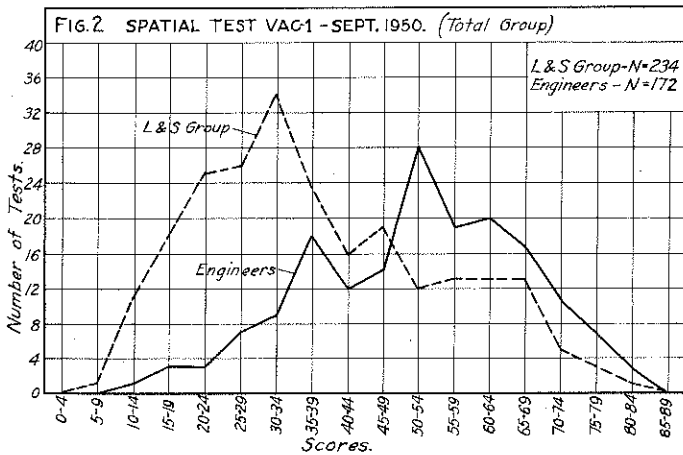

a. Comparison Between Engineering and L & S Matriculates. Analysis of the scores of both groups indicates that the engineers were definitely superior to the L & S group in the possession of this trait at the beginning of the year. Figure 3 shows that the engineers averaged 13.4 score points more than the L & S group, and calculation of  $D/\sigma$  dif. indicates that this was a highly reliable difference between the averages of the two groups. The frequency distribution chart of Figure 2 bears out this conclusion still further.

FIGURE 3. FIRST SPATIAL TEST DATA - TOTAL GROUP

Group	Average Score	$\sigma$	$\sigma \bar{x}$	$\sigma$ dif.	$D/\sigma$ dif.	N
Engineers	51.7	17.34	1.32	1.66	8.1	172
L & S Group	38.3	15.27	1.00			234

This considerable difference in favor of the engineers may be accounted for in two ways. First, the engineering group is of better scholastic quality than the L & S group. This is attested by two facts.

1. A tabulation of percentile rank in high school graduating class indicated that 59% of the engineers ranked in the 75th percentile or better, as against 44% of the L & S group.
2. A tabulation of rank on the American Council Psychological Examination, 1948 Edition (the only general intelligence test taken by all freshmen) gave the engineering group 31% in the 75th percentile or better, the L & S group 19%.

A second reason for the difference may lie in the areas of aptitude and motivation. Most freshmen electing to take engineering feel that they have some aptitude for it. That there is some basis for this feeling is evidenced by the data from a questionnaire filled out by all examinees at the time of the first testing, and asking for information concerning the types of work and hobbies engaged in outside of school time. A classification of the various answers showed that 66% of the engineering group had engaged in work or hobbies of a mechanical nature, while only 51% of the L & S group had been so engaged.

While this aptitude for things mechanical is not the only, nor even the most important qualification of engineering, nevertheless, it may well be the basis for a greater motivation toward a definite goal than is the case among L & S freshmen. Many of the latter often do not elect a major, nor select a professional school until their junior year.

b. Comparison Between Engineers and Outside Groups. To provide some adequate idea as to the general quality of this engineering group with respect to the trait being studied, a comparison of the results of this test (VAC-1) was made between them and two outside groups of matriculating freshmen. These results are tabulated in Figure 4.

FIGURE 4. COMPARISON WITH OUTSIDE GROUPS ON TEST VAC-1

Group	Average	$\sigma$	$\sigma \bar{x}$	$\sigma$ dif.	$D/\sigma$ dif.	N
U.W. Engineers	51.7	17.3	1.32	---	---	172
C.E.E.B. 1947 <sup>1</sup>	52.3	16.1	.51	1.41	.43	1000
West Point 1949 <sup>2</sup>	53.0	16.0	.66	1.48	.90	591

<sup>1</sup> From a random sample of 1000 College Entrance Board Examinees furnished by Education Testing Service.

<sup>2</sup> From Research Bulletin 51-6, Educational Testing Service.

Both of these latter groups could be considered in the category of "select" groups, rather than random samples of all matriculating freshmen. Of the College Entrance Examination Board group (CEEB), the Educational Testing Service says "Probably the group--represents a group of better than average ability, in comparison with the average entering freshman class." The West Point group is the freshman class of 1949, generally selected for entrance to the Military Academy on the basis of competitive examinations of which VAC-1 was not a part. It should be noted, in Figure 4 that the slight difference between the averages of the engineers and each of the other groups is so small as to have no statistical significance. This fact is borne out by the calculated  $D/\sigma$  dif. which in each case, is far below the generally accepted value of 2 indicating high reliability.

While no particular control is exercised by the College of Engineering over the scholastic quality of its entering freshmen (except for the one requirement that they present a minimum of 2 high school units of mathematics) it would appear from the foregoing data that this group might also be considered in the category of a "select" group.

**8. IMPROVEMENT IN THE TRAIT RESULTING FROM A YEAR OF UNIVERSITY WORK** - At the conclusion of the second testing, the scores of those taking both tests were analyzed and tabulated in Figure 5, which shows a comparison between the first and second testing of both groups.

Attention is directed to two items in this table. First, the average improvement in score of the engineering group is 5.7 score points greater than that of the L & S group. Second, a comparison of the standard deviation ( $\sigma$ ) of the two groups shows the engineers much more closely clustered about their average than is the case with the L & S group. In the case of the second testing, the sigma of the engineering group decreased appreciably, while that of the L & S group showed a slight increase.



FIGURE 5. COMPARISON BETWEEN GROUPS TAKING BOTH TESTS.

Group	Test Date	Average	Av. Imp. in Score	$\sigma$	$\sigma \bar{x}$	$\sigma$ dif.	D/ $\sigma$ dif.	N
Engineers	Sept. 1950	56.0	12.2	13.2	1.24	1.65	7.4	114
	May 1951	68.2		11.6	1.08			
L & S	Sept. 1950	39.3	6.5	16.9	1.52	2.16	3.0	124
	May 1951	45.8		17.1	1.54			

Reference to the frequency distribution charts of Figure 6 emphasizes this difference between the groups. The engineers show a distinct upward trend along the scale of scores, while the L & S scores show the second

the basis of equal math entrance units. Sixty-two pairs resulted, with a range of scores from 22 to 82. Again, averages, sigmas, and reliability coefficients were computed and tabulated in Figure 8.

An even more striking difference in average increase in score points results from this comparison, than that

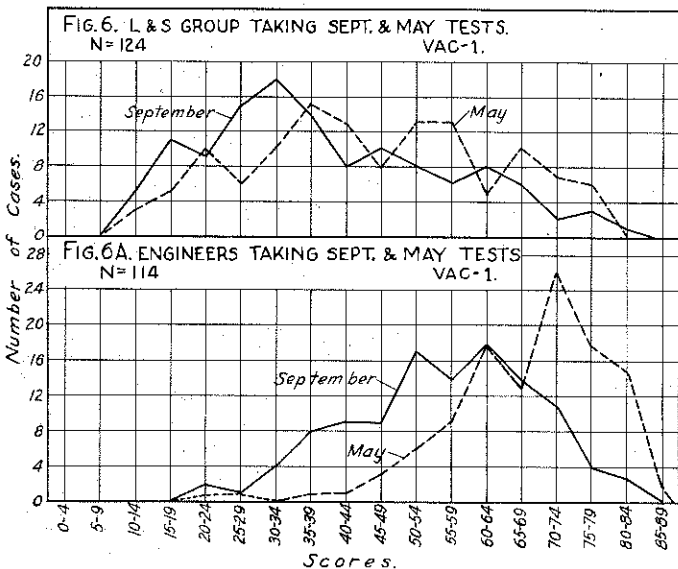

FIGURE 7. NUMBER AND AMOUNT OF SCORE CHANGES - BOTH GROUPS

Points change in score	Number making increase	
	Engineers	L & S
over 30	1	0
25 - 30	5	1
19 - 24	10	13
13 - 18	38	20
7 - 12	38	34
1 - 6	16	22
none	3	6
(-1) - (-6)	3	18
(-7) - (-12)	0	7
(-13) - (-18)	0	1
under - 18	0	2
N	114	124

FIGURE 8. COMPARISON OF PAIRS TAKING BOTH TESTS

Group	Test Date	Average	Increase in Score Points	$\sigma$	$\sigma \bar{x}$	$\sigma$ dif.	D/ $\sigma$ dif.	N	Av. Math Ent. Units
Engineers	Sept. 1950	51.6	13.1	14.1	1.78	2.43	5.4	62	3.3
	May 1951	64.7		13.0	1.65				
L & S	Sept. 1950	51.6	4.5	14.0	1.77	2.56	1.75	62	3.0
	May 1951	56.1		14.6	1.85				

testing just as widely scattered over the entire range as was the case with the first test.

The trend in score change is summarized in Figure 7. From an inspection of the table, it can be seen that the engineers are closely grouped in the positive section of the table, while the L & S group is widely spread over the whole table. The actual range is from 31 to -2 for the engineers, and from 26 to -29 for the L & S group.

9. COMPARISON OF THE GROUPS BY INDIVIDUAL PAIRING - As a further, and more accurate measure of the difference between the two groups, the method of individual pairing was employed. Individuals from each group were paired on the basis of their scores in the first test. Where an excess of score in any one numerical group occurred, pairings in that range were made as nearly as possible on

shown in Table 5. The engineers' average increase over the first test average was 13.1 score points, or 25.6%, while the L & S group increased but 4.5 score points, or 8.8%. It should be noted also that the difference between the two averages of the L & S group is not of too high an order of reliability, as indicated by the D/ $\sigma$  dif. of 1.75.

Again the same tendency for the standard deviation ( $\sigma$ ) of the engineers to decrease and of the L & S group to increase is to be seen here although the changes are not as marked as in Table 5.

The frequency distribution chart for the paired groups (Figure 9) included here confirms graphically the data of the table.

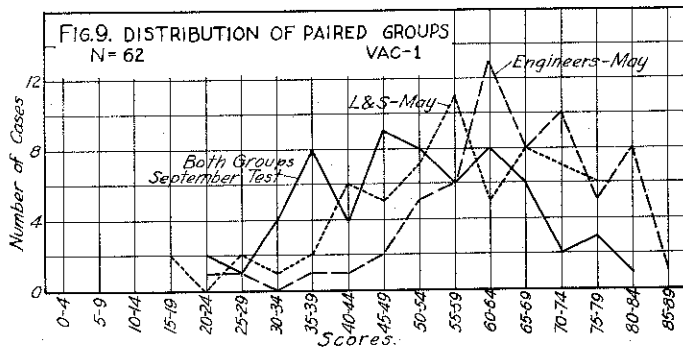

10. GENERAL CONCLUSIONS - From the data contained in the three foregoing sections several quite definite conclusions emerge. These conclusions are concerned primarily with improvement in the trait of spatial visualization, and not with the amount of the trait shown by the groups at any particular time. Therefore comparisons have been made, and conclusions based upon the increase in scores between first and second tests, rather than upon the score averages themselves. The conclusions follow.

a. The moderate increase in score points of the L & S group between the first and second testings indicates that there is probably some improvement in the trait after two semesters of college attendance. The average measure of this improvement probably lies somewhere between the score point increase of 6.5 in Figure 5, and the 4.5 increase of Figure 8. However, the reliability of these differences between first and second test averages is open to some question, due to the low  $D/\sigma$  dif. found in the case of paired groups (Figure 8).

No distinct or general trend in scores, either upward or downward, was noticeable in the L & S group, as is evidenced by the frequency distribution chart of Figure 6. In fact the curve of the May test, when rounded off to a smooth curve would approximate quite closely the normal curve of a chance distribution. Nor would the standard deviation of either the total group or the paired group indicate any such trend, the increase of the sigmas on the second test showing rather, an increase in the spread of the scores. And while the tabulation of L & S score changes (Figure 7) shows a large number of moderate score increases, these are considerably offset by a large number of decreases. In fact 27% of the L & S group taking both tests either made no gain or had a lower score on the second test; and these cases were not confined to any particular score brackets, but distributed over the entire range.

These facts would seem to point toward the conclusion that scholastic work, as such, had little direct effect upon the L & S group scores. Rather, maturation of the student in his year at college, and perhaps some remembrance of the first testing were chiefly responsible for any increase in score. It is from this natural, or chance, score increase as a base that we will evaluate the extent of the gain in the engineering group.

b. The improvement in the trait among the engineering group, as measured by the test scores, was of such considerable magnitude and high statistical reliability, and so general throughout the group, that it cannot be entirely attributed to the factors of maturation and remembrance.

In Figure 5 the average increase in score of all the engineers taking both tests was 12.2 points, or 22% of the first test average. However, this increase was 87.7% greater than the average increase of the L & S group. In a similar comparison of the paired groups of Figure 8, (probably the more accurate indication of relative change between groups) the engineers' average increase was 13.1 score points, which was 25.6% of the first test average, and 190% greater than the average L & S increase. In

addition, these differences between the engineers' averages are, in each case, of a high degree of reliability, as shown by the  $D/\sigma$  dif.

Bug a comparison of averages does not tell the whole story. The frequency distribution curve of the May test (Figure 6A) has a much more pronounced negative skewness than does the September curve indicating a very considerable movement to the higher scores on the second test. The May curve of the L & S group, by way of contrast, approximates the normal distribution curve. Furthermore, the engineers' decrease in standard deviation on the May test (Figures 5 and 8) shows a greater clustering of the scores about the higher May average. The reverse of this was the case with the L & S group.

The wide extent, and considerable amount of the increase in scores in the engineers' group is shown in Figure 7. Only six, or 5.3% did not better their first scores, while 27% of the L & S group failed to improve their scores.

c. If we assume that maturation and remembrance would cause the same amount of improvement in the trait among engineers as among the L & S groups, then the facts set forth in a and b above, point definitely to the conclusion that some more potent factor than these was operating to cause the significantly greater improvement which the engineers show. Since there is no great difference between the extra-curricula life of the freshman engineer and other freshmen, except (presumably) that he spends more time in study, it would appear that the cause for the additional improvement must be sought for in differences in the type of scholastic work pursued by the two groups. Accordingly, a brief analysis of the courses taken by them is presented here.

11. ANALYSIS OF THE SCHOLASTIC WORK - To trace to its source the scholastic factor causing the greater improvement among engineers, we must consider first, those courses which gave similar educational experiences to each group, and second, those courses which gave exclusive experiences to the engineering group.

The freshman engineering course follows a fixed pattern consisting of four major subjects (Chemistry, Drawing, English, and Mathematics) continuing through both semesters of the year, and two minor subjects (Speech and Shop) each taken for one semester, and of smaller credit value. In the case of the L & S group, the pattern is not fixed, and a great diversity of subjects is found. However, the pattern may be simplified and reduced to comparable proportions by classifying the subjects in five general categories, viz.: Mathematics, English, Natural and Social Sciences, and Humanities. Certain of the engineering courses may be similarly classified.

Thus the classification shown in Figure 10 has been set up. It does not follow exactly the order given above but has been devised to illustrate likenesses and differences between the courses followed by the two groups. The figures in the table have been arrived at by assigning one point for each subject taken by each student for one semester. Thus, if all of the 114 engineers took the required two semesters of mathematics, the total in this compartment would be 228. Only one point was given when a subject was failed and then repeated. Admittedly, the table is inaccurate for academic credit computations, since it gives equal weight to 3, 4, and 5 credit courses, and unduly emphasizes the minors. It does, however, indicate quite accurately the number of semesters of scholastic experience the men involved in the study have had in each subject, and therefore admits of comparisons between the groups.

The first item that we may note in making this comparison is that English and the natural sciences are as heavily represented in one group as the other. Thus, they can be expected to have about equal influence on both groups, as far as improvement in spatial visualization is concerned. In fact, the advantage, if any, may be in favor of the L & S group, for several of the natural sciences such as Botany, Geography, and Geology

FIGURE 10. TOTAL SEMESTERS OF COURSES TAKEN BY BOTH GROUPS

	Shop	Drawing	Math	English and Speech	Natural Sciences	Social Sciences	Language History	Misc. Humanities	N
Engineers	2 & 3 cr. - 67 1 cr. - 47 <u>114</u>	216	216	Eng. - 194 Sp. - 46 <u>240</u>	Chem. - 213 Phys. - 2 <u>215</u>	4	0	0	114
L & S	0	0	160	Eng. - 212	Bot. - 23 Chem. - 93 Geog. - 73 Geol. - 20 Astr. - 2 Zoo. - 52 <u>263</u>	Econ. 5 Pol.Sci. 38 Physch. 4 Sociol. 52 <u>99</u>	Lang. - 64 Hist. - 25 <u>89</u>	Art - 1 Class - 1 Music - 5 Phil. - 2 <u>9</u>	111*

\* Thirteen members of the L & S group entered the course in Integrated Liberal Studies. Since the integrated subjects given in this course do not admit of classification as made above, they have been omitted from the table.

should be more effective in promoting improvement in the trait than the Chemistry courses of the engineers, since they require the exercise of the student's visualizing abilities in sketching, reading, and interpreting various natural forms.

As a second item, the table shows some disparity in mathematical experience on the part of the L & S group, which, although not excessive (an average of 1.44 semester per man as against 1.89 semesters for the engineers) deserves some consideration here. While it can be argued that this disparity may account, in part, for the greater improvement in the trait among engineers, little reliable evidence is found to support this thesis.

Comparable differences in college mathematical experience occur only in the L & S group, where a small number (24) of the total group had taken no mathematics during their freshman year. Figure 11 is a pairing (on the basis of the first spatial test) of these 24 cases with others in the L & S group that had two semesters of mathematics. A comparison of the increase in the spatial test averages would seem to be to the advantage of those with two semesters of mathematics. However, the reliability coefficient of 1.18 is of too low an order, and the size of the group too small, to consider this as conclusive evidence of the effect of mathematics.

Perhaps a better idea of its effect on the trait may be obtained from the correlation chart of Figure 12.

It may be noted from this table that only in the middle range of mathematics grades (4, 5, 6) is there found a great preponderance of cases with about average gains in the spatial test. Furthermore, of 26 cases below the mathematics average line, 11 or 42% made better than average gains. It would appear from this that high quality work in mathematics is not necessarily correlated with great improvement in the trait.

Further evidence of this was a correlation<sup>4</sup> made between the scores of the second spatial test and the third semester mathematics (calculus) grades of all the engineering group with this data available. The resulting coefficient of correlation (+.287) was of a very low order of significance. Thus from the available evidence, it may be concluded that experience in college mathematics had little measurable effect upon improvement in the trait.

The third item to be considered in Figure 10 is the two groups of courses taken exclusively by engineers. They are:

a. Elementary shop courses in fundamental shop operations, involving largely manual skills. These courses were minors in credit value, occupying at most four hours per week for one semester. While the students handled, and operated on, physical objects, they were not specifically required to exercise their visualizing ability in the work.

FIGURE 11. EFFECT OF COLLEGE MATH ON SPATIAL TEST

Pairing of 24 cases having no math with those having two sem. math.  
Basis of pairing - (1) 1st spatial test, (2) math aptitude test.  
(All cases from L & S group)

Group	Test Date	Average	$\sigma$	$\sigma \bar{x}$	$\sigma$ dif.	D/ $\sigma$ dif.	N
Both groups	Sept.	35.5	15.4	3.14			
No math	May	40.0	15.5	3.16			
2 sem. math	May	45.2	15.0	3.06	4.4	1.18	24

<sup>4</sup> Project #52037 U. of W. Computing Service.

FIGURE 12. CORRELATION CHART  
 Between Grades Attained in 2 Sem. of College Math  
 And  
 Points Gained (Or Lost) in Second Spatial Test.  
 Cases from L & S Group Only. N = 66

Attained grades in Mathematics*	Points gained (or lost) in second spatial test								
	-11 to -8	-7 -4	-3 0	+1 +4	+5 +8	+9 +12	+13 +16	+17 +20	+21 +24
8			1		3	3	1	1	
7	2	1			2	1	2	1	
6			1	1	2	3	1	2	1
5		1		1	1	2	1	3	2
4		3			2	1	1	2	1
3			2	1	2	1			
2	1				2			2	
1			1				1	1	
0			1			1			

4.95  
Av.

8.7 Av.

\* Sum of two semester's grades on the basis - A=4, B=3, C=2, D=1, E & F = 0.  
 Four would thus be the equivalent of barely passing grades in both semesters.

b. Drawing courses including both elementary mechanical drawing and descriptive geometry. These are major courses in credit value, occupying six hours per week throughout two semesters, with assigned home study. Emphasis in these courses was placed on the ability to solve problems graphically by means of visualizing and reasoning.

From the foregoing analysis of the content of Figure 10 it would seem that the significantly greater improvement of the engineers in spatial visualization may be attributed primarily, and in large part to the scholastic experiences obtained in their drawing courses.

12. **SUMMARY OF CONCLUSIONS** - We here briefly recapitulate the conclusions arrived at in this study, as measured by the spatial tests given.

a. Engineering matriculates possess the trait of spatial visualization to a considerably greater (35%) degree than other University matriculates.

b. While over the period of a school year there is some improvement in the trait among non-engineers, it is not general throughout that group, nor large enough to be of too great statistical reliability. Its incidence seems largely due to the factors of maturation and remembrance.

c. In spite of their much higher initial scores on the spatial test, the improvement of the engineering group was of such considerably greater magnitude than the general group that it could not be attributed entirely to the same factors which caused the improvement noted in h.

d. Analysis of the scholastic experience of the two groups indicated that the principal area of difference between them lay in the drawing and shop courses pursued exclusively by the engineers.

e. Since the shop courses did not specifically stress spatial visualization, it would seem that the primary factor in the engineer's added improvement was to be found in the work pursued in the drawing courses.

**ANNUAL MEETING — 1955**

**PENNSYLVANIA STATE UNIVERSITY**

**STATE COLLEGE, PA.**

**JUNE 20 - 24, 1955**



## ENGINEERING DRAWING: DYNAMIC? OR STATIC?

by

Professor J. E. Shigley  
Clemson Agricultural College  
A & M College of South Carolina

Too many teachers of engineering drawing are satisfied with the subject the way it is. They say drawing is a language; a means of communicating ideas; an analytical tool. They enlarge upon these points in great detail and show how a working knowledge of this language improves the mind and the power of visualization. These statements have been made so many times and on so many occasions that their significance has become dulled. Perhaps it is true, as Hitler stated, that if a statement is made often enough people will believe it. But it is also true that if a statement is made often enough it will soon lose its significance.

Why do they make these repetitious statements?

Teachers of drawing are concerned because they feel that those who shape engineering curricula are not attaching enough importance to drawing in the education of an engineer. They feel that they are being placed in the "back seat" due to this decreased emphasis. Questionnaires have been circulated recently which imply that teachers of drawing are at the bottom of the ladder in the salary scale, that they occupy the poorest and least desirable space in the engineering buildings, that their equipment and supply appropriations are small, and that they are being attached to other departments for reasons of economy. So, in order to justify their existence in the scheme of things, they tell about how important drawing is, and willingly pour out their sorrows to anyone who will lend an ear.

No one will dispute the speed with which the world has progressed technologically in the past 15 years. Even without considering the advent of atomic energy and all of the associated developments, really tremendous strides have been made in all fields of engineering. No one will dispute this and a listing of these developments here would be merely repetitious. The important fact is that these technological advances are beginning to make themselves felt in the shaping of engineering curricula. This fact is not new, but it is in the interpretation of this fact that we are now interested.

Engineering is a dynamic science. Its borders are being pushed back daily. New problems occur, new methods of solution appear, new materials and processes become available. In fact the progress is so rapid that we are now told that we should not teach purely descriptive or operational courses, since the methods taught may no longer be in use in a few years. Those in charge of curricula changes are, of course, well aware of these facts because they can look back over the courses of 15 and 20 years ago; when they do so, the change and improvement is obvious. As Dean Grinter has stated, "Engineering is changing from an art to a science." Only a brief comparison between present-day texts and those used 15 or 20 years ago will clarify this statement amply.

Consider now the field of engineering drawing. What contributions to the expanding technology can be credited to this field beyond those routine tasks of conveying information by means of drawings? What additions to

knowledge have been made? How has engineering drawing contributed to the simplification of analysis and synthesis? Is the field of engineering drawing dynamic? Does the growth and development of this subject correspond with that of other engineering fields?

If, as they say, engineering drawing is a tool for analysis which not only clarifies thinking, but also greatly simplifies analysis, why has it not been so used? The list of engineering problems, fundamentally simple, but complicated to analyze, and very difficult to interpret, grows every day. Few graphical methods of solution have been applied, and those that have been are difficult to use and to understand. One of the greatest restrictions on the development and expansion of knowledge are the complexities which arise. If engineering drawing is an easy-to-use tool which clarifies thinking, then its use has most certainly been neglected. If these complexities can even be softened by engineering drawing, then a great contribution to science will have been made.

Teachers of engineering drawing who are trying to justify their existence should take a positive approach, not a negative one. Results speak louder than words. If engineering drawing is to regain its importance in the curricula, it must do so by making significant contributions to knowledge. It must become dynamic. The teacher must take an aggressive attitude.

It is said that drawing offers a fertile field for the initiation of the creative process. If this is so, then teachers of the subject are certainly in an advantageous position, not only to do creative work in engineering drawing, but to assist in extending the borders of knowledge in other fields. Unsolved problems and complex problems are available without end. The writer offers the following as examples:

1. Metal-alloy equilibrium diagrams. These are complex and very difficult to understand. A new graphic interpretation is needed.
2. The solution of electrical networks. No graphical solution is in general use. It is doubtful if one is available. A graphical method of interpreting or analyzing these is needed.
3. The solution of magnetic circuits. A new graphical interpretation of these problems could conceivably open wide the doors for new scientific developments.
4. The solution of simultaneous linear differential equations. Graphical assistance could be of tremendous significance in the solution of this broad class of problems.
5. Three-dimensional graphs and charts. These are difficult to construct and to use. If a simple means of constructing and using them were available the method would have fundamental usefulness in all fields of science and engineering.

6. Agricultural implements for working soils. The design of most of these is on a pure trial-and-error basis. The design of a plow, for example, is a "natural" for graphics. Yet this field has only been scratched.

The problems listed above are typical, but anyone who is sufficiently interested may find others in any field of engineering.

Even the field of engineering drawing itself is a

fertile field for growth and development. Drawings do not exist which adequately convey the dynamics of the machine or structure which is described. Someday a drawing will be made such that the reader will feel the vibration of the engine, and the rush of air past his cheek. When a drawing conveys the elastic and plastic motion of structures due to wind and earthquake, then perhaps it may be called a static science. But, who knows, perhaps sometime drawings may even communicate the heat and smell of the exhaust.

## ANNOUNCEMENTS

### NOMINATIONS FOR 1955 DISTINGUISHED SERVICE AWARD

The committee for this year's Engineering Drawing Division Distinguished Service Award will meet sometime after April first to make the selection from the nominations received. Will you kindly prepare your nomination, together with substantiating biographical data and mail this to Clifford Springer, 209 Transportation Building, University of Illinois, Urbana, Illinois. Nominations will be received until April 1, 1955. Refer to May, 1952, issue of the Engineering Drawing Journal for rules regarding this award. The committee is particularly anxious to have a heavy response to this notice.

### TESTS ON DISPLAY AT PENN STATE

Irwin Wladaver  
New York University

At the Pennsylvania State University this coming June you will again be treated to an opportunity to examine an array of tests and quizzes in engineering drawing and descriptive geometry.

You will, that is, if you cooperate with your Committee on Tests as thoroughly as you did last year. Last year's voluminous and varied display at the University of Illinois was well attended. In fact, it was so well received that such an exhibit may possibly become a regular feature of the annual meetings of the Drawing Division of the A.S.E.E.

In the next month or so a letter will reach your school. You will be asked to put together for the Penn State meeting in June a batch of typical tests and quizzes in current or in recent use in your courses. The particular type of quiz you use makes no difference. All types have their advantages -- and their disadvantages. In no sense is the exhibit to be a competition. The purpose is to keep teachers in touch with current testing practices, with obvious benefit accruing to students and teachers alike.

In the meantime, your Committee thanks you for last year's help. And thanks in advance for this year's contribution to the display of tests at Penn State.

The following schools have 100% of their departmental membership subscribing to the Journal of Engineering Drawing:

Clemson Agricultural College  
Iowa State College  
University of Maine  
University of Ohio

To the Chairman of Engineering Drawing:

I'd like to enlist your help, in the interest of the Division of Engineering Drawing and Descriptive Geometry.

The "T-Square Page" of the JOURNAL OF ENGINEERING EDUCATION is a forum from which we can speak to teachers of other engineering subjects. We can use the Page to put them in touch with ideas, practices, and developments in our field that they ought to know about. What better way do we have to further our own interests and increase our stature in engineering education?

If you agree that this is important, I'm sure you'll want to cooperate in the following way: Ask the members of your staff--and this includes you, of course--to send me an article on any topic in our field that might influence or interest teachers of other engineering subjects. In this way we'll be able to present a variety of viewpoints on a variety of matters. In addition, we'll have a backlog of material suitable for future publication.

An article should be about 550 or 600 words in length. If it runs over a page and is particularly well written, it will still stand a good chance; we can get extra space for an outstanding contribution. And if it's too long for the T-Square Page, I'll forward it to Professor Warren J. Luzadder, Editor of the JOURNAL OF ENGINEERING DRAWING, for consideration of publication in the Division's fine periodical.

I'll acknowledge any article I receive and make whatever comments may seem appropriate.

Cordially yours,



Irwin Wladaver  
Editor, T-SQUARE PAGE

Address:

Box 5  
College of Engineering  
New York University  
New York 53, N. Y.

**HAVE  
YOU  
RENEWED  
YOUR  
SUBSCRIPTION  
?**

## GENTLE READER

### WE ARE:

A "One-Horse" publishing house - and proud of it. Although we should like to grow bigger, we have no desire to be a giant, or even to be a large firm. It is much more fun to operate a small enterprise.

Ten years ago, the need for a workbook and the willingness of the author's to venture their own money gave us our start. Since then our publications have been extended until we now have seven books, two of which enjoy a pitifully small sale - less than 100 copies per year. Even so, we desire to publish another book or two.

### WE WANT:

- A. College workbook or textbook material. Although offset printing has been used on our other books, we would use whatever means seemed appropriate considering appearance, cost, and potential market.
- B. Material with an assured market for possibly 500 copies.

### WE CAN OFFER:

- A. To copyright material in the author's name.
- B. To pay excellent royalty rates, 12 per cent on the first 500 copies, 18 per cent on others.
- C. To release to another publisher, if the author wishes, after the first printing is sold.
- D. Considerable experience in the preparation of illustrations.

### WE HAVE:

Books for sale, including

Laboratory Manual of Materials Testing, 2nd Ed. by E. C. Thoma. \$2.50

Engineering Graphics and Descriptive Geometry by Porsch, Elrod and Hammond. \$3.50

Problems in Engineering Graphics and Descriptive Geometry, 2nd Ed. by Porsch, Elrod and Hammond. \$3.00

Problems in Engineering Drawing - Abridged 3rd Ed. by Luzadder, Arnold, and Thompson \$1.50

Chemistry Laboratory Manual (Being Revised) by Alberts and Schlosser

### WE WON'T:

Be disappointed if the subscribers to the Journal of Engineering Drawing show this to acquaintances who may be potential authors or users of our books.

## B A L T P U B L I S H E R S

*Southworth's Extension Service, Shipping Agents*

308½ STATE STREET

WEST LAFAYETTE, INDIANA

CHART DISTORTION IN THE CONSTRUCTION OF NOMOGRAMS

by  
 Professor Clyde H. Kearns  
 The Ohio State University

The nomogram is widely recognized in technical work as a valuable method for the graphic representation of relationships between variable quantities and the solution of problems involving such relationships. A study of the use of functional scales in slide rules, coordinate systems and nomograms, is a desirable part of any course of training for the engineer. It is proposed, herein, to discuss briefly one phase of nomography, namely, the use of chart distortion in the construction of nomograms.

be straight or curved, are then located by the intersections of appropriate tie lines or joins.

Another procedure is one in which characteristic chart forms, i.e., parallel scales, z-chart, etc., are associated with particular equation types. Sufficient geometric analysis is made of each chart form to establish formulae for the layout of the scales. This method is described by practically all texts on nomography.

A third procedure involves the writing of the chart equation as a vanishing third-order determinant of special form. The first and second elements of the rows of this determinant provide functions of each variable which enable the scales to be plotted on rectangular coordinates. An advantage exists in that all chart forms are embraced by a single theory. Other factors, however, may not be conducive to success. Difficulty may be encountered in converting the equation to proper determinant form. This conversion often resembles a "trial and error"

The construction of a nomogram to represent a specific equation relating three variable quantities may follow one of several procedures depending upon the form of the equation and the degree to which the author wishes to become involved with theoretical considerations. Certain forms involving simple addition or multiplication of terms may be constructed by laying out two scales of suitable type and modulus along parallel straight stems. Points on the third scale, which may

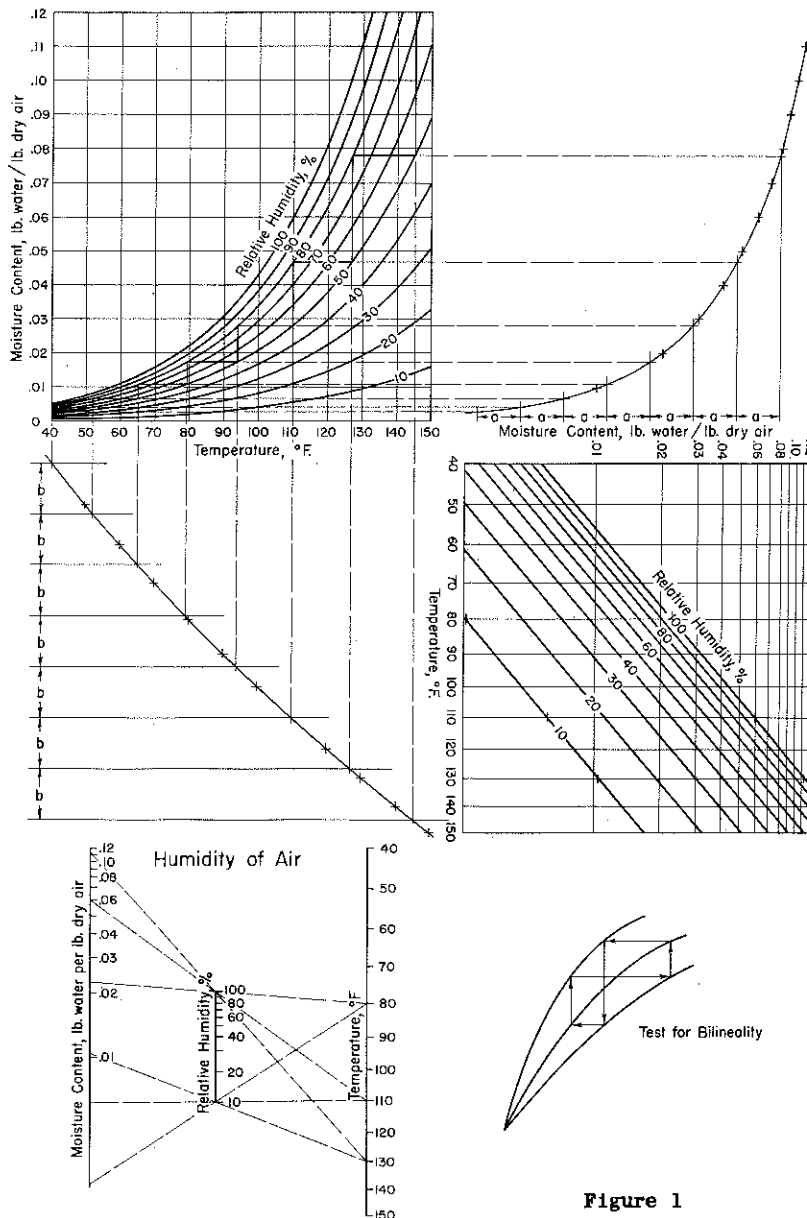

Figure 1



process and may require appreciable time and effort. It may also be the case that, after a determinant has been obtained, the resulting chart does not plot in suitable proportion and poor intersections are obtained between scales and tie lines. A mathematical transformation of the determinant or a method of graphic distortion is then prerequisite to suitable scale configuration.

Because the engineer is often concerned with the results of experimental work, a relationship between three variables may take the form of tabulated data for which an empirical equation has not been established. Such data plots on rectangular coordinates as a family of curves with two of the variables serving as ordinate and abscissa and the third as parameter. A nomogram may be constructed if the curves are linear on equispaced coordinates or if they can be transformed to straight lines by the use of one or two function scales in place of the uniform coordinate scales.

Figure 1 illustrates the graphic distortion of the coordinate scales of a line graph by the method devised

by Lafay<sup>1</sup>, quoted by d'Ocagne<sup>2</sup>, and described in detail by Mavis<sup>3</sup>. The relative humidity curves of the psychrometric chart on equispaced rectangular coordinates at the upper left are converted to straight lines by the following procedure:

a. Beginning with the point on the 50% relative humidity curve at the left boundary of the original graph, a series of vertical and horizontal lines is drawn to form a "stair-step" construction between the 50% and 80% curves.

b. The "treads" are projected horizontally to the right onto a series of equispaced vertical lines and the "risers" vertically downward onto a series of equispaced horizontal lines. A curve of transformation is drawn through each resulting set of points. The two intervals, "a" and "b," are not necessarily equal and care should be exercised in selecting them since they establish the size and proportions of the new chart.

c. The uniform coordinate scales of the original graph are projected onto the curves of transformation and

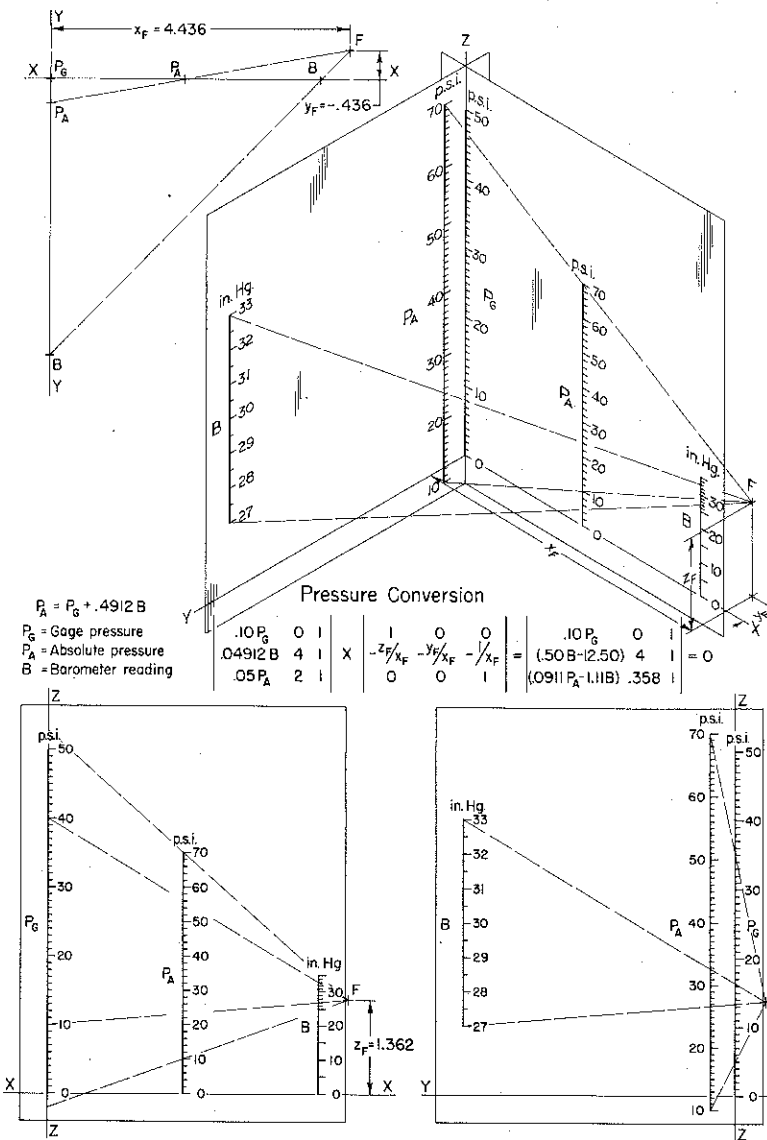

Figure 2

1 Lafay, Auguste, "Note sur la représentation approchée des équations à trois variables de la forme  $\gamma(z) = \alpha(x) + \lambda(x) \beta(y)$ ," *Le Genie Civil*, v. 40, p. 298-299, (March 1, 1902).  
 2 d'Ocagne, Maurice, "Traite de Nomographie," Gauthier-Villars et Cie., 2nd Ed., pp. 449-454, (1921).  
 3 Mavis, Frederic T., "The Construction of Nomographic Charts," *International Textbook Co.* pp. 114-120, (1935).

thence at right angles into the new chart. The functional coordinate scales so formed are oriented at right angles to their original position.

d. The relative humidity curves of the original graph are transferred by projecting three or more points of each onto the curves of transformation and thence into the new chart.

A family of parametric straight line curves on any type of rectangular coordinates can be represented by a nomogram having two straight parallel scales. The Humidity of Air nomogram at the lower left in Figure 1 is constructed according to the method described by Mavis<sup>4</sup> as follows:

a. The functional scale of ordinates is rotated to a vertical position to become the Moisture Content scale of the nomogram.

b. The functional scale of abscissas is placed at a convenient chart width from and parallel to the first to become the Temperature scale of the nomogram.

c. Two points are selected on each straight line curve and the coordinates noted. Tie lines corresponding to each pair of points intersect to locate a point on the Relative Humidity scale of the nomogram. A third point and corresponding tie line check each intersection. Because of the positive slope of the straight lines, Moisture Content and Temperature scales must run in opposite directions if the Relative Humidity scale is to lie between them.

Some families of curves may be transformed to straight lines by the distortion of only one of the coordinate scales. Any two smooth curves may be transformed to parallel straight lines by a two-scale distortion. All the curves of a family are not necessarily rectified by the transformation of two. Wertheimer<sup>5</sup> described the "test for bilineality" shown at the lower right in Figure 1. The three curves have the "closure property" if, everywhere along their length, the construction of the rectangular steps forms a closed figure. For three curves having a common point, the "closure property" is a necessary and sufficient condition that they be representable by straight lines on some kind of functional coordinates. In order to test a family of curves it is necessary to successively test three at a time. Wertheimer presented no satisfactory test for noncurrent curves.

Gage pressure may be converted to absolute pressure by the formula,

$$P_A = P_G + .4912 B$$

where  $P_A$  is absolute pressure in p.s.i.,  $P_G$  is gage pressure in p.s.i. and  $B$  is barometer reading in inches of mercury. In the form of a nomographic determinant, the equation becomes

$$\begin{vmatrix} P_G & 0 & 1 \\ .4912 B & 1 & 1 \\ .5 P_A & .5 & 1 \end{vmatrix} = \begin{vmatrix} .1 P_G & 0 & 1 \\ .04912 B & 4 & 1 \\ .05 P_A & 2 & 1 \end{vmatrix} = 0$$

Figure 3

Coefficient of Radiant Heat Transfer  
(emissivity=1)

$$h = \frac{0.172[(T_1/100)^4 - (T_2/100)^4]}{T_1 - T_2}$$

$$\begin{vmatrix} 0.1163 h & 1000 & 1 \\ \frac{2T_1^4 \times 10^{-10}}{T_1 + 1} & \frac{1000T_1}{T_1 + 1} & 1 \\ \frac{2T_2^4 \times 10^{-10}}{T_2 + 1} & \frac{1000T_2}{T_2 + 1} & 1 \end{vmatrix} = 0$$

$h$  = Coefficient of radiant heat transfer, BTU per hr. per sq. ft. per °F difference  
 $T$  = Temperature, °R.

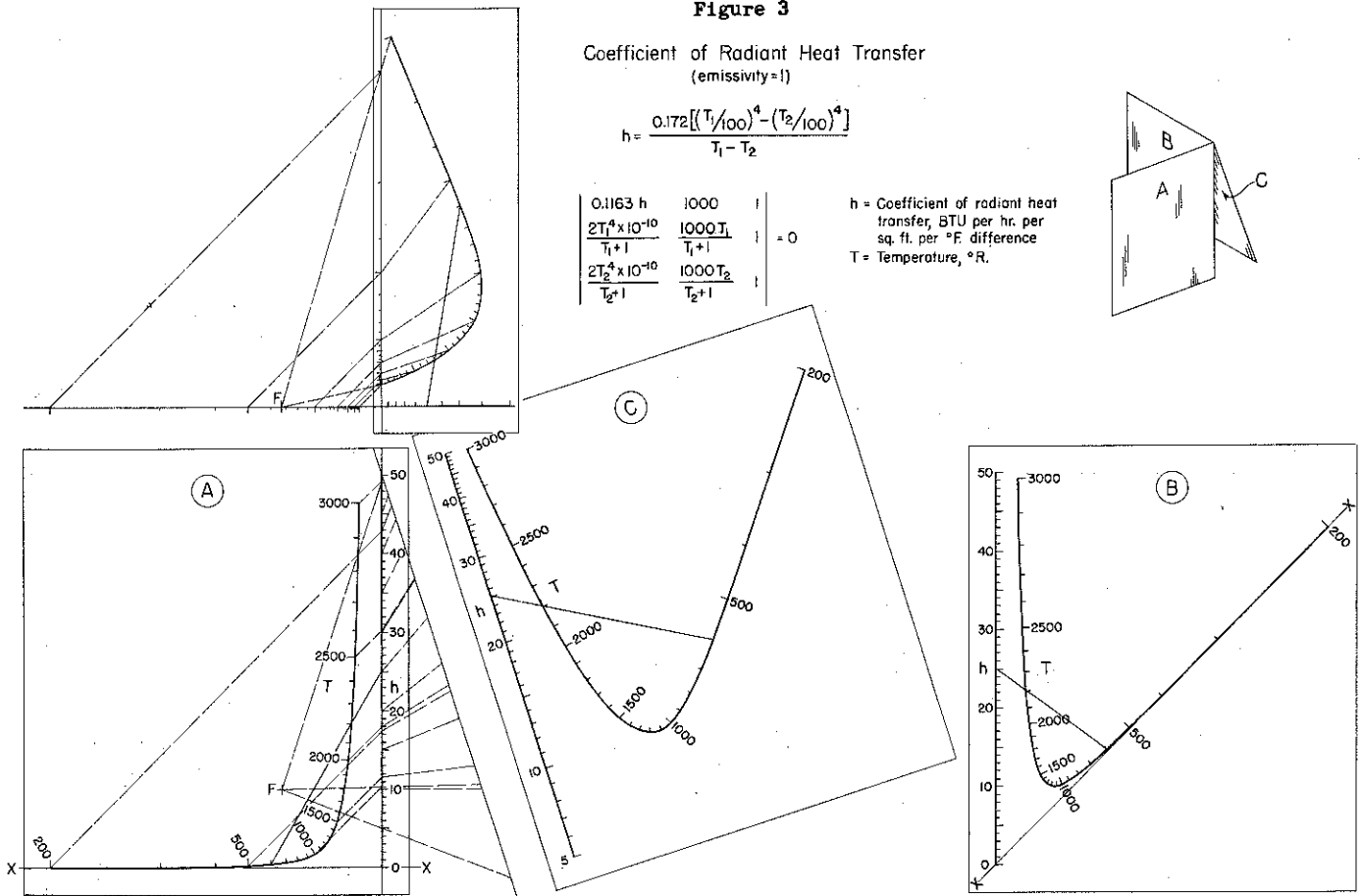
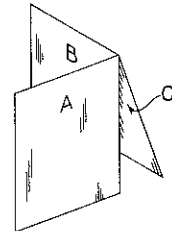

<sup>4</sup> Ibid., pp. 95-104.

<sup>5</sup> Wertheimer, Albert, "The Graphical Transformation of Curves into Straight Lines and the Construction of Alignment Charts," Journal of the Franklin Institute, v. 219, pp. 343-363, (March, 1935).

and the plotting of the functional scales on the frontal XZ plane of Figure 2 results in the nomogram at the lower left. In this form, however, the chart is unsuitable. Barometer readings normally fall within a small range of values in the vicinity of 30 inches and so a large portion of the scale is not used. A Barometer Reading scale of appropriate range and length is obtained through projection of a portion of the nomogram onto the profile YZ plane by rays from a focus, F. The new chart appears in the view at the lower right.

A pictorial view of the transformation is shown at the upper right in Figure 2. It can be seen that the Gage Pressure scale, lying along the intersection of the two planes, is unchanged. As indicated by the accompanying equation, the graphic transformation is equivalent to a multiplication of the original zero-valued determinant by another third-order determinant described by Mavis<sup>6</sup> as a "matrix of transformation." Evaluation of the matrix is not difficult. The fact that the Gage Pressure scale is unchanged establishes the values of the elements in the first and third rows as unity or zero. The elements in the second row are evaluated in terms of the coordinates of the focus by similar triangle relationships in Figure 2.

The coefficient of radiant heat transfer from a body at temperature,  $T_1$ , and of emissivity equal to unity, through a non-absorbing medium, to "black" surroundings at temperature,  $T_2$ , is given by the formula,

$$h = \frac{0.172 [ (.01T_1)^4 - (.01T_2)^4 ]}{T_1 - T_2}$$

where  $h$  is the coefficient of radiant heat transfer in BTU per hour per square foot per degree Fahrenheit difference and  $T$  is the temperature in degrees Rankine. In the form of a nomographic determinant, the equation becomes

$$\begin{vmatrix} h/0.172 & 1 & 0 \\ (.01 T_1)^4 & T_1 & 1 \\ (.01 T_2)^4 & T_2 & 1 \end{vmatrix} = \begin{vmatrix} 0.1163 h & 1000 & 1 \\ (2T_1^4 \times 10^{-10})/(T_1 + 1) & 1000 T_1/(T_1 + 1) & 1 \\ (2T_2^4 \times 10^{-10})/(T_2 + 1) & 1000 T_2/(T_2 + 1) & 1 \end{vmatrix} = 0$$

and the plotting of the functional scales on the frontal plane of Figure 3 results in nomogram "A" at the lower

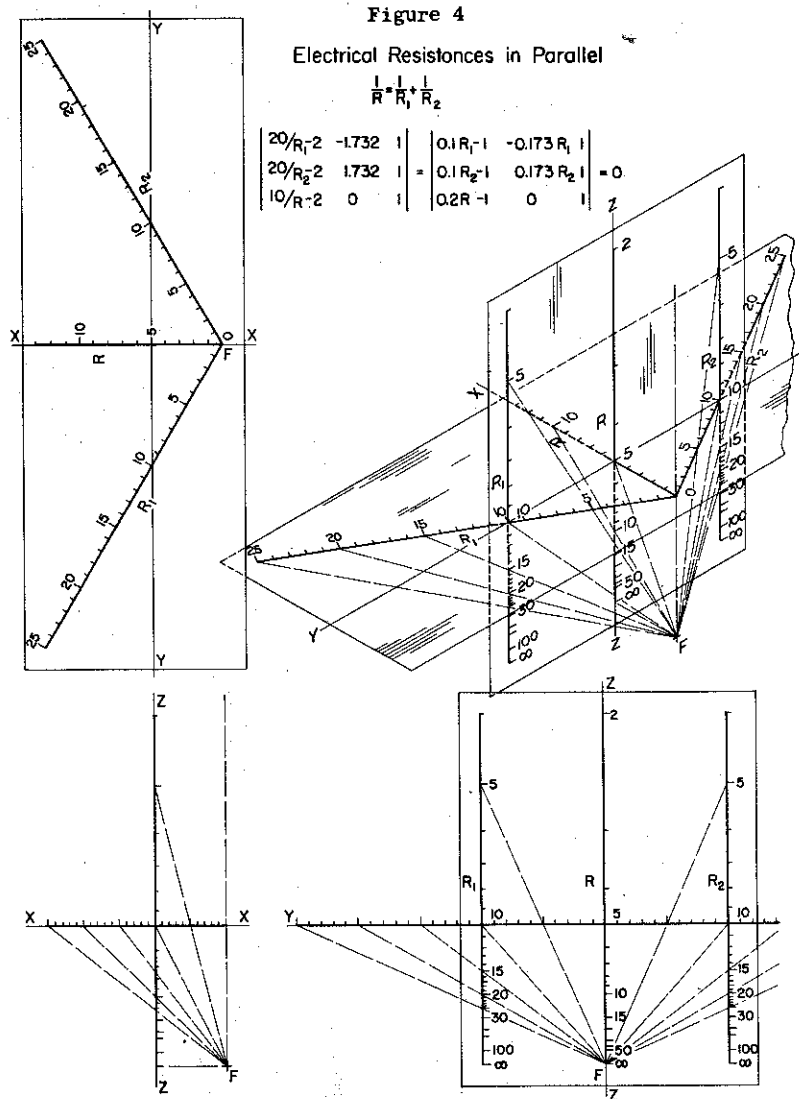

<sup>6</sup> Mavis, op. cit., pp. 49-62.

left. Because the elements of the second and third rows are identical functions of  $T_1$  and  $T_2$ , the corresponding scales coincide to give a single Temperature scale. Tie lines must cross the Temperature scale at values of both  $T_1$  and  $T_2$ . The shape of the curved scale is such that it does not lend itself to suitable chart proportions.

Accordingly, a two-stage graphic transformation is carried out. The first stage involves projection of the chart onto a profile plane along rays parallel to the body diameter of the cube. The resulting nomogram "B," in which the Coefficient scale remains unchanged, is shown at the right of Figure 3. The second stage is accomplished through projection of nomogram "B" onto a diagonal plane by means of rays from a focus, F. The final result of the transformation, nomogram "C," appears in the right auxiliary view. The tie line connecting the values,  $T_1 = 2200$ ,  $T_2 = 600$  and  $h = 25.04$ , is shown in each stage for purpose of comparison. The equivalent algebraic transformation of the determinant is not indicated.

The fact that the equation for electrical resistance in parallel,

$$1/R = 1/R_1 + 1/R_2$$

may be represented by nomograms of "different" form is illustrated in Figure 4. The nomogram of three parallel reciprocal scales plotted on the profile YZ plane at the lower right is converted by projectors from a focus, F, to a nomogram of three concurrent uniform scales on the horizontal XY plane at the upper left. The "equal spacing" between scales is maintained in the projection by reason of the position of the focus. As indicated by the accompanying equation, the determinant forms corresponding to each chart are algebraically equal.

The foregoing are typical examples of the use of chart distortion in the construction of nomograms. The methods involved are not of recent origin. Opportunities exist, nonetheless, for further study and development. A suitable test for bilinearity in the case of nonconcurrent curve families would be desirable. Further investigation of the geometric and algebraic significance of the projective transformation of nomograms might lead to better methods for the evaluation of the matrix of transformation in the general case of projection from one plane onto another. Certainly, no course of study in nomography is complete without a presentation of these valuable and interesting graphic procedures.

## PERSONALITY SKETCH OF PROFESSOR WILLIAM WIRT TURNER

by

Professor C. P. Buck  
University of Notre Dame

On November 27, 1889, the population of Matville, West Virginia radically increased when William Wirt Turner began life, the son of Captain William and Martha Hinchman Turner. He was the youngest of a family of nine children that has included two doctors and a university president.

Of his boyhood and manhood I can tell you little, except that one thing seems certain, he was taught to have a great respect for work and perseverance. His middle name might well be Work instead of Wirt -- he certainly has earned it. He is seemingly tireless, and one of the very few things that try his patience is when any





one working with him does not seem to care much whether things get done or not.

He earned his A.B. degree from Morris Harvey College in Charlestown, West Virginia in 1911, but early took an interest in architecture. After some special courses at Catholic University (1913-14) he decided to continue his formal education along these lines. He entered Notre Dame and in 1916 received a B. S. degree in Architecture. In 1918 he received a M. Arch degree also from Notre Dame.

The entry of the United States into the first World War found Bill among the first ten thousand to go overseas. He served with the U.S. Army Engineers. Whenever possible, he spent his leaves continuing his education in architecture by roaming about France as far as he was able, to study the famous churches, chateaus, and early Roman buildings. Once his interest nearly cost him his life when he and a friend narrowly escaped being murdered and robbed by ruffians in the Pyrennes.

During the period between 1911 and 1920 he worked for the Bethlehem Steel Corporation when he was not furthering his education or overseas. Back in the U. S. after the war, he became interested in teaching. His educational background, his natural friendliness, and a great liking for young people made him a natural to enter the field. He accepted a position teaching drawing at Central High School in South Bend, Indiana, in 1920.

In 1921, he married Grace ("Bobbie") Robertson of Edmonton, Alberta, Canada. They have two children, William, Jr., now a surgeon with the U. S. Air Force, and Mrs. Virginia Hull of Indianapolis, and two grandchildren, Linda Sue and Kenny Hull.

Bill taught at Central High School for sixteen years. Then, in 1936 he joined the staff of the Department of Architecture at the University of Notre Dame. In 1942, he was offered and accepted the headship of the Department of Engineering Drawing, which position he has held ever since.

Even though he shuns the limelight, Bill is well known by many in the Drawing Division because of his contributions to our field. His first book was a text in Mechanical Drawing published by Wiley. Written primarily for high school use, it was used by some colleges for an introductory course. In later years it was translated into Portuguese. Perhaps his classic work was Fundamentals of Architectural Design, first published by McGraw Hill in 1930. Though Bill would be the last to admit it, there are probably few people in our profession today who have as complete and thorough a knowledge of perspective. His books and charts covering this phase of the work certainly bear testimony to the fact.

Since 1944, he has published three work books in Engineering Drawing; a work book in freehand sketching for engineers; three texts in architectural drawing -- Simplified Perspective, Shades and Shadows (including a set of work sheets), and Projection Drawing for Architects. He has co-authored a text which combines engineering drawing, descriptive geometry, and machine drawing and also co-authored a work book in descriptive

geometry. All of these latter books have been published by Ronald Press.

One would suppose that after having written or helped write ten books in his field, that Bill would be content to ride along and rest on his laurels. However, this is not for him; he seems to have an inner main spring that winds up again before it has run down. When not working on a new textbook or work book, he is working on classroom problem material and tests, or on his pet hobbies of making models and classroom charts. He has developed a series of large scale charts for every different course he has taught. Many will remember his paper on these charts at the St. Louis Summer School, which subsequently was written up in the "Proceedings."

Frequently it is the seemingly insignificant every day things that endear a leader to his men. Such things, for example, in Bill's case, as his great sense of fairness in his dealings with his fellow man -- even men he has found it hard to get along with and they are extremely few; his reticence in discussing his own personal problems; his willingness to let the other fellow get the medals, if the job he feels should be done -- gets done. These are some of the more subtle things.

He is not above playing a practical joke that causes no physical harm, nor in return, have I ever seen him become angry when the shoe was on the other foot. The men in the department enjoy his tales of the West Virginia "hills" -- frequently told with a twinkle in his eye, and as frequently "questioned" by his listeners.

Outside of the classroom, he is a devoted family man. He was a member of the band of "Do-It-Yourself" ers long before it was given any special recognition as being the "thing" to do. He became interested in doing his own paper-hanging to the extent that he might be classified as an "expert," were it not for his personal aversion to the term. He used to have a standing "agreement" to paper a friend's room in return for a meal -- though I don't believe he ever pressed for collection of his "wages." He enjoys fishing -- salt water preferred. He is an avid football and baseball fan; in his college days, he was a member of the baseball team.

He is held in high esteem by the entire faculty, administration, and those of the alumni of Notre Dame, as well as Central High School, who have had the good fortune to have had him as a teacher. This past June he was publicly honored at the Notre Dame Commencement Exercises by being picked to be the recipient of the \$500 faculty award given by the administration and the alumni for outstanding service to the University.

There is an old story from Laotzu's Book of Toa, written in 600 B.C. that fits Bill about as well as could be expressed:

"A leader is best when people barely know that he exists, not so good when people obey and acclaim him, worst when they despise him. ----- But of the good leader, who talks little, and when his work is done, his aim fulfilled, they will all say, 'We did this ourselves'."

MEETS THE NEEDS  
OF THREE GROUPS  
STUDENT, TEACHER,  
PRACTICING ENGINEER

# FRANK ZOZZORA

PROFESSOR OF GENERAL ENGINEERING  
HEAD, ENGINEERING DRAWING AND DESCRIPTIVE GEOMETRY  
THE UNIVERSITY OF DELAWARE

## ENGINEERING DRAWING

369 pages • 8½ x 11 • 650 illus. • \$5.00

This text on engineering drawing meets the needs of three groups, and is specifically designed to present the essentials of the course in a short concise manner. The three groups . . . student, teacher, practicing engineer. It provides the student with the fundamentals of engineering drawing without requiring him to learn specialized details and techniques that will prove of

little value in his professional career. For the teacher it offers the opportunity to cover comprehensively the essentials of the subject in the limited time allotted in the present-day curtailed curriculum. For the practicing engineer it affords an invaluable reference for review of basic procedures.

### OUTSTANDING ILLUSTRATIONS

Over 600 carefully annotated illustrations make this book an extremely teachable text. The liberal use of attractive pictorials side by side with corresponding orthographic views aid the student in visualizing

three-dimensional relationships. Many helpful notes on the illustrations guide the thinking of the student to a clear understanding of the problem.

### CONCISE TREATMENT

The chapters and topics are carefully selected and arranged in a sequence that leads to easy progress in the study of the subject. After the chapter on lettering the student is introduced directly to orthographic projection, which is then followed by a chapter on freehand drafting. This permits the student to apply orthographic-projection, which is then followed by a chapter on freehand drafting. This permits the student to apply orthographic-projection theory immediately without first having to master the use of instruments. Thereafter the text covers the use and care of instruments, geometrical constructions, shop processes, dimensioning, sectioning and conventional practices, auxiliary views, pictorial drawings (isomet-

rics and obliques), fasteners, assembly drawing, intersections and developments, cams and gears, and inking practice. No attempt is made to cover in detail the specialized fields of architectural drawing, aircraft drawing, jigs and fixtures, charts, graphs, perspective, and illustration. A detailed appendix is included containing tables and design information on commonly used fastening devices, on the classification of fits, and on other related matters. There is also an extensive bibliography of texts, pamphlets, and ASA Standards, and a comprehensive list of visual aids that may be used to supplement classroom lectures.

Send for copy

# McGRAW-HILL BOOK COMPANY

# ENGINEERING DRAWING PROBLEMS

KEYED TO ZOZZORA'S ENGINEERING DRAWING

72 pages

\$3.75

## FEATURES

The work sheets in this book are directly keyed to Zozzora's textbook, *Engineering Drawing*; however, the material can be used in conjunction with any other standard text on the subject.

The plates offered are of a sufficient number and variety to cover the fundamental principles of the regular course work. Supplementary problems may be assigned from the text used.

The lettering plates have been placed at the front of the book, because of the importance of the subject in the preparation of acceptable drawings.

The problems have been carefully selected to acquaint the student with the necessary basic rules and conventions, and are arranged according to the most widely accepted method used in teaching the subject matter. The various kinds of paper generally employed in industrial usage have been used so that the student may become familiar with the particular conditions presented when called to work on cross section, tracing, or opaque papers.

The instructions and text references are printed in the margin of each sheet for ready reading and to avoid needless moving or turning of pages.

To aid the student in visualizing the objects many problems are shown pictorially. Where a problem entails demonstration of only one or two learning points it is presented as a partial layout to save extra time.

## CONTENTS

Engineering Lettering  
Orthographic Projection (Freehand)  
Alternate Positions of Views  
Line and Plane Analysis  
Freehand Drafting  
Geometric Construction  
Instrumental Drawing  
Shop Questions  
Dimensioning  
Limit Dimensioning  
Sections and Conventional Practices  
Primary Auxiliaries  
Secondary Auxiliaries  
Pictorial Drawing (Isometric or Oblique)  
Thread Representation  
Fasteners  
Welding  
Riveting  
Assembly Drawing  
Intersections and Developments

is on approval

, Inc., 330 West 42nd Street, New York 36, N. Y.

## GRAPHICS IN AN EXPANDING SCIENTIFIC AGE

by

Professor A. S. Levens

University of California at Berkeley

Just what is the place of graphics in the preparation of the engineer for an expanding scientific age? What material should be included in college-level courses in graphics? In the re-evaluation of engineering education, what has become of graphics - and all that implies? To what level has it been relegated in the curriculum? These are pertinent questions!

Preliminary reports of the Committee on the Evaluation of Engineering Education seem to indicate that the formal study of graphics has been virtually relegated to the past.

Currently this committee has been actively engaged in a study "to determine the pattern or patterns that engineering education should take to provide the leadership that the profession must have 25 years from now." The committee recognizes the significant progress that has been made in the physical sciences during the past decade and its impact upon the profession of engineering. The preliminary report presented in the November, 1953, issue of the Journal of Engineering Education points out the increasing importance of the basic sciences in engineering progress. As examples of the increased importance, the committee cites developments in electronics; problems related to structures; research in heat transfer; fluid mechanics; jet and rocket propulsion; metallurgy, etc.

The committee stresses the importance of the basic sciences - mathematics, physics, and chemistry - in engineering curricula. It suggests that mathematics through ordinary differential equations seems close to a minimum essential for all engineers. It recommends greater emphasis upon basic science in engineering education. The committee recognizes nine important background sciences in engineering. These are: statics, dynamics; strength of materials; fluid flow; thermodynamics; electrical circuits; fields and electronics; heat transfer; engineering materials; and physical metallurgy. The committee believes "that all of these studies should be represented in curricula that train engineers for service in research, development or design, and that probably seven should be integrated into every curriculum that is represented as education for engineers."

Many engineering educators would agree with the committee's view of the importance of the basic sciences and the recognition of the "background" sciences in engineering. Personally, I do not quarrel with what has been included but rather with the omission of a very important and basic field - graphics.

Should not the study of graphics be represented in all engineering curricula? In my opinion, our engineering students will not be adequately prepared to meet the technological challenges of today nor of the future without (a) thorough knowledge and use of the fundamentals of projection; (b) reasonable proficiency in graphical representation - working drawings, pictorial sketches, etc.; (c) knowledge and use of graphical calculus, introductory phases of nomography, and graphical methods of computation.

Our students should become aware of the fact that nearly all solutions of engineering problems are at best close approximations; that judicious use of various methods may be advantageous. In some cases the mathematical tool is best, in others the graphical, in still others a combination of the two methods is indicated, and in certain instances a combination of graphical, mathematical,

numerical, and mechanical methods is best suited to the analysis and solution of phases of an engineering problem. Certainly it would be considered poor engineering to insist upon a mathematical solution when, for example, a simpler and sufficiently accurate graphical solution is available. We have become, by training, accustomed to the use of algebraic methods in solving problems, and we have developed a "reverence" for the reliability of answers that are obtained by such methods. Many students believe that "correct" answers to problems obtained by the manipulation of equations are exact. This may be true for "ideal" problems. Often problems are concerned with time, temperature, pressure, length, etc., quantities that can be measured only approximately. The reading of a thermometer, for example, can only be as accurate as, among other things, the graduated scale (graphical) and the visual acuity of the observer. This is also true of lengths, whose measurement again depends upon a graphical scale; or of pressure, whose measurements depend upon a gage mechanism and a scale for reading numbers; or of voltages, currents, and many other quantities which are measured by devices that indicate values of a scale which is read by an individual. The data are graphical in nature. Certainly many problems that inherently are based on such data can be solved by graphical methods with sufficient accuracy.

We know that thorough training in mathematics is essential to sound engineering and scientific training. It is, however, important for students not to get a warped view; for their training should lead to the intelligent use of several methods, and, it is hoped, to the development of good judgement in the choice of methods.

Institutional committees and engineering faculties continue to study the reports of the A.S.E.E. committee and are giving serious thought to the development of effective curricula. Some schools are reluctant to give up specialization and yet wish to retain a four-year program that, in my opinion, cannot possibly include approximately 20% in the non-technical areas, and greater stress on fundamentals. It is important to recognize the fact that a five-year program is indicated if some specialization is to be considered, and if we are to provide education for the potential professional engineer. We should stop kidding ourselves that a four-year undergraduate program is adequate for the preparation of professional engineers who will be charged with the responsibilities of the scientific age.

When it is attempted to broaden the engineers' undergraduate education to include sounder and more thorough training in the basic and engineering sciences, to provide for a more cultural experience, and in addition to retain specialized options, some areas must be minimized. Unfortunately, one of these has been the field of graphics - a field which is as basic, in my opinion, as is mathematics.

If the recommendations (1944) of the Committee on Engineering Education After the War had been implemented, I believe that our curricula could easily provide sufficient time for basic training in graphics. This committee pointed out that "some of the advanced technical subject matter now included in undergraduate curricula should be transferred to the post-graduate period where it may be pursued with a rigor consistent with preparation for engineering specialization."

The tentative draft of the committee's report did include under the heading Nondepartmental Engineering Courses - (frankly, I am at a loss to understand this classification) - the following paragraph: "Graphical representation is both a form of communication and a tool for analysis. Its professional usefulness may be evaluated in terms of its success in these directions. Its value as a skill alone does not justify its inclusion in a curriculum. The ability to convey ideas by drawing should be measured at an appropriate time and where deficient, should be developed so that its use is evident in the reports presented in advanced courses. Another ability to be developed in this study is spatial visualization. Since most creative engineering work is initiated by the process of illustrating ideas by sketches, it is believed that an experience in the use of technical sketching that may be obtained in drawing offers the opportunity for initiating the creative process."

It should be noted that whereas the tentative draft included the above statements - (although no specific reference is made to the importance of graphical solutions and computations) - I can find no reason for the omission of graphics as a curricular subject in the published preliminary report of last November. Surely the members of the committee and engineering faculties are aware of the importance of graphics to industry; its importance to the design engineer; to the "idea-engineer"; to production personnel, etc.

Perhaps what is lost sight of is the importance of graphics in the preparation of our students for professional engineering. Without a thorough knowledge and use of the fundamentals of orthogonal projection, reasonable proficiency in graphical representation - working drawings, pictorial sketches etc.; knowledge and use of graphical calculus, of introductory phases of nomography, and of graphical methods of computation, our students will not be adequately prepared to meet the technological challenges of today nor of the future.

For years we have pointed out the values of training in graphics - development of perceptive ability, visualization, power to think through, analyze and solve a variety of three-dimensional problems that arise in the various fields of engineering; inspiring the young engineering student, instilling in him the spirit of engineering, helping him to develop desirable traits such as punctuality, resourcefulness, initiative, orderliness, ability to work with others - traits that employers regard as important as scholastic ability.

We must continue to point out these values, and, in addition, the steps that have been taken in the past decade to revitalize our courses in keeping with the growing demands of the scientific age. Several schools have, for instance, for some time modified their basic courses to include not only the fundamentals and applications of orthogonal projection, technical drawing practices with increasing emphasis on the use of freehand drawing, but also introductory treatments of graphical methods of computation, graphical mathematics, including graphical calculus, vector geometry, functional scales and their application of empirical relations and to the design of concurrency and alignment charts.

It is my firm conviction that this is a move in the right direction. It is my earnest hope that many schools will work toward similar programs. The success of such programs will depend upon (1) well-prepared teachers, (2) a cooperative faculty, and (3) sufficient time for preparing the student.

The preparation of teachers can be accelerated to

some extent by (1) seminars, (2) workshops, and (3) annual conferences at the A.S.E.E. division level.

As to cooperation with faculty, I cannot over-emphasize the importance of working with our colleagues in other fields: engineering, physics, chemistry, zoology, etc. How can we expect our colleagues in engineering to fully carry over the knowledge and experiences the student has acquired in the basic courses of graphics when it is realized that many members of the faculty have not been in close contact with the broader scope of graphics, and do not appreciate the fact that significant changes have been made in recent years.

Certainly we should make every effort to encourage our colleagues who teach such courses as mechanics, strength of materials, thermodynamics, design, etc., to participate in the teaching of graphics.

At the University of California at Berkeley, we have had some success in this connection. We have had men from the fields of industrial engineering, internal combustion engines, thermodynamics, and mechanics participate in teaching graphics courses. Recently we received one request from an associate professor in fluid mechanics and another from a professor in petroleum engineering to work with us in graphics. We are looking forward to association with members from the electrical and civil engineering divisions in the near future.

In our engineering design division nearly all members of the staff teach graphics courses. As a consequence, the integration of graphics with mechanics and machine design is greatly enhanced.

In this manner, we can develop more effective integration of the basic graphics courses with all fields in engineering, and more importantly, our students will be much better prepared to use all phases of graphics to advantage.

Then, too, we should seize upon every opportunity to work with colleagues who are active in research. We should be available, whenever appropriate, to render service both to graduate students and to industry.

For example, one of our professors in electrical engineering was interested in the application of graphical calculus to the solution of a problem that arose in the field of micro-wave optics. This problem concerned the determination of the directional radiation characteristics of a micro-wave antenna system. This was accomplished by measuring the amplitude and phase of the electric field across a straight aperture in the near-zone region of the antenna system. From these measurements the far-zone field was calculated. Graphical differentiation was employed in the solution because an algebraic solution was much too cumbersome, if at all possible. (Fig. 1.)

In another case a member of the mechanical engineering staff wanted to know how to employ graphical differentiation in connection with problems in engineering economy. The first one (Fig. 2) dealt with the determination of the number of articles per unit time that could be produced to yield maximum profit. The second one (Fig. 3) was concerned with the relationship between costs and benefits.

In two other cases, assistance was given in the design of nomograms, one that dealt with "Performance of Vertical Single Stage Ammonia Compressors," (Fig. 4) and the other with the "Determination of Fixed, Operation, and Maintenance Costs of Refuse Collection." (Fig. 5.)

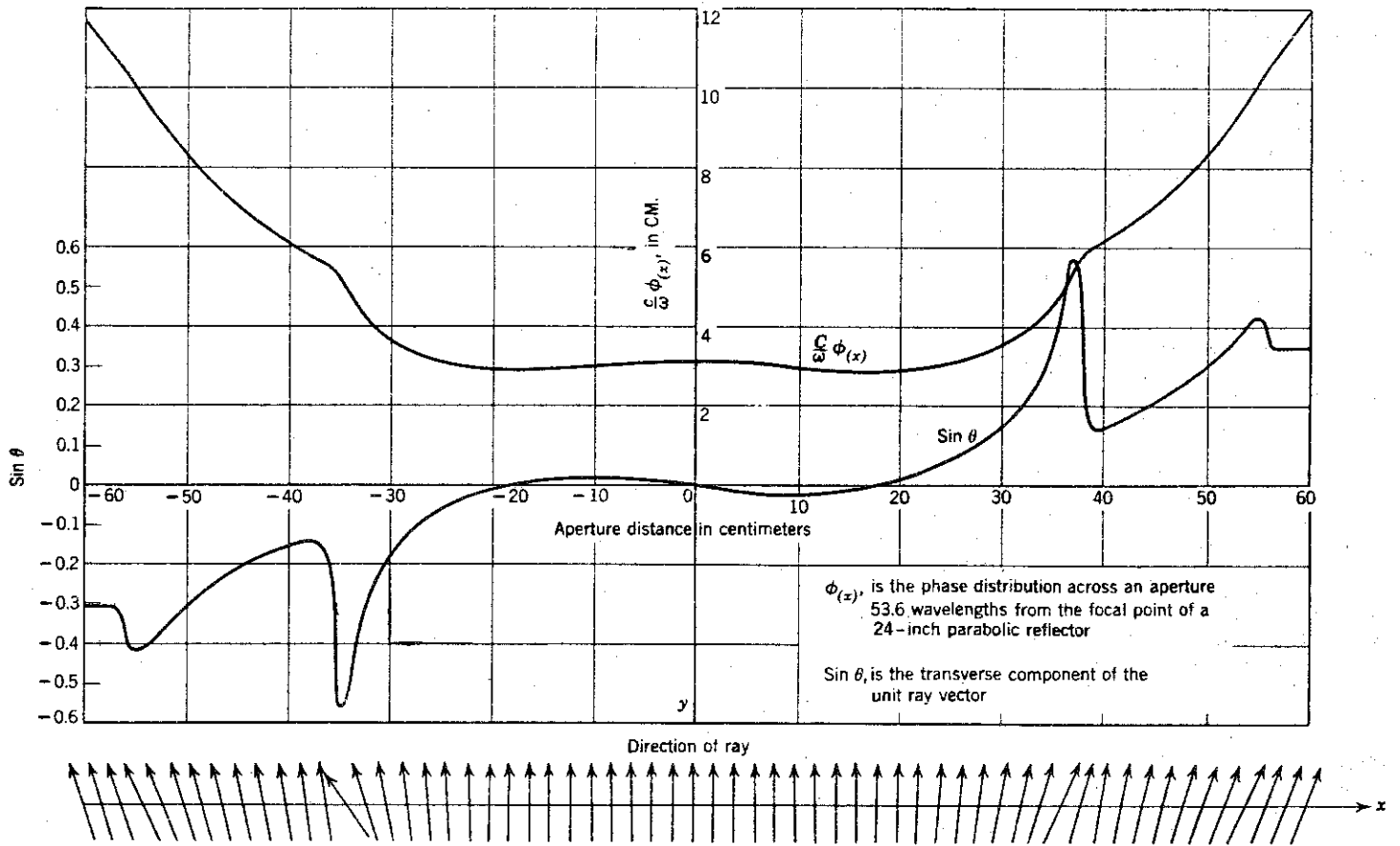

FIG. 1. APPLICATION OF GRAPHICAL DIFFERENTIATION TO MICROWAVE OPTICS

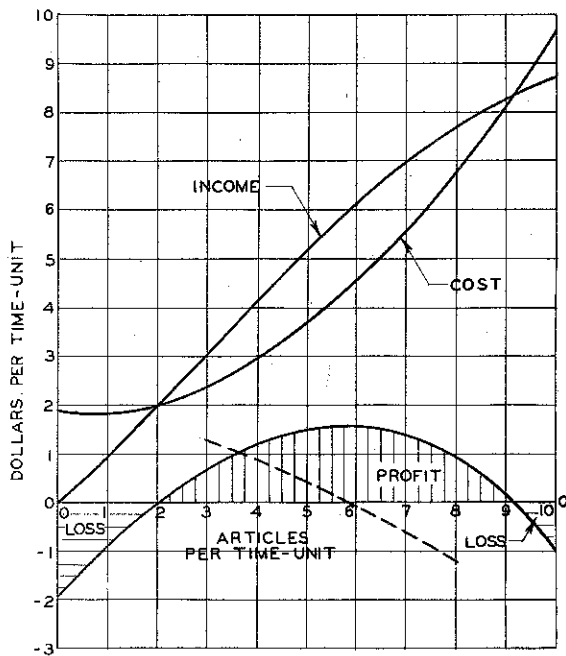

FIG. 2 DETERMINATION OF "MAXIMUM PROFIT-ARTICLES PER TIME-UNIT" RELATION

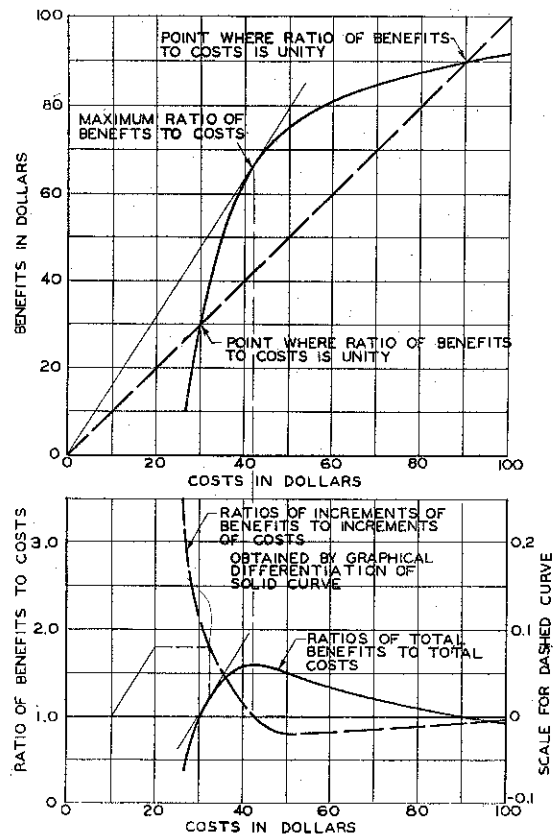

FIG. 3 BENEFIT-COST RELATIONSHIPS

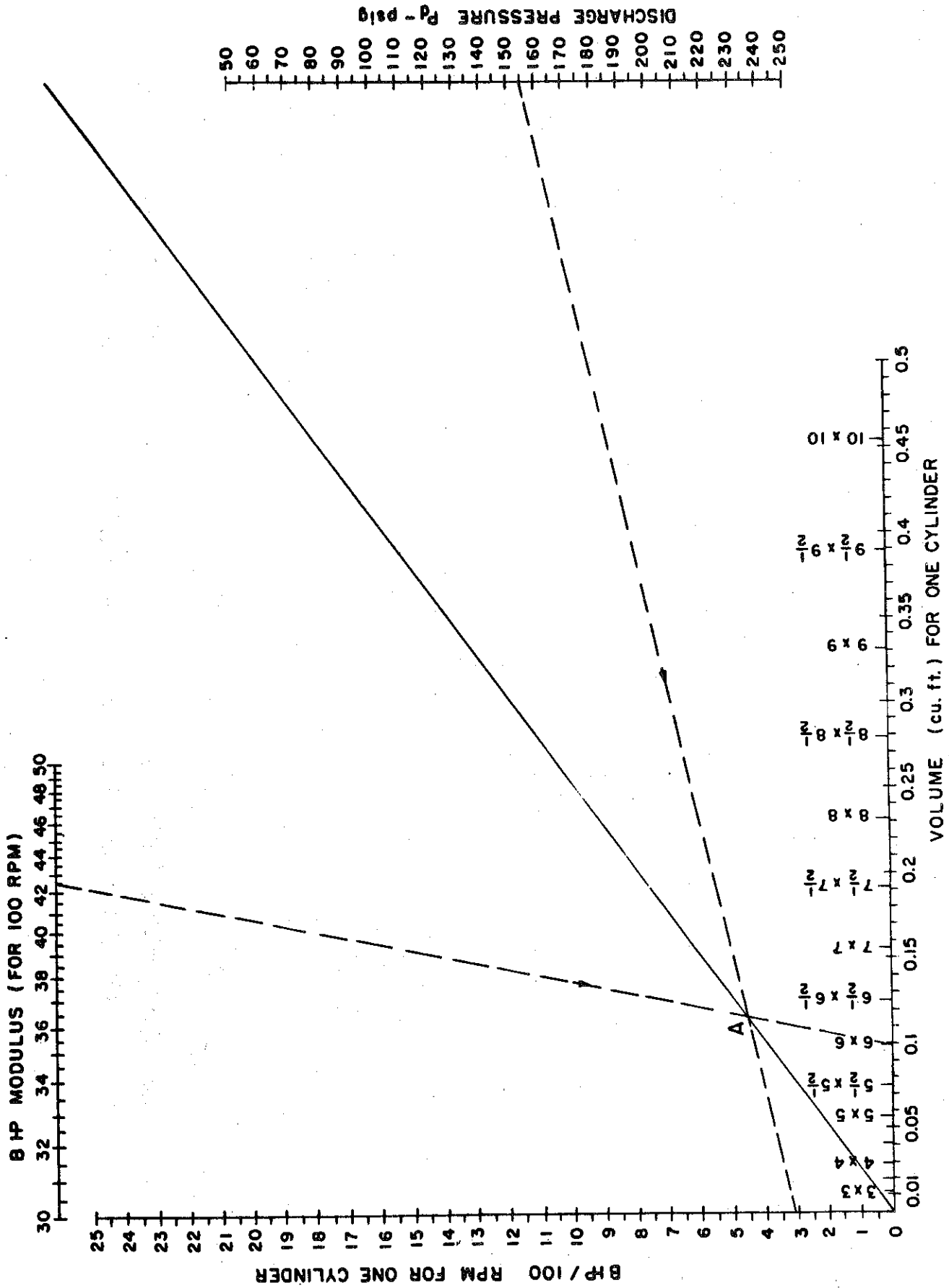
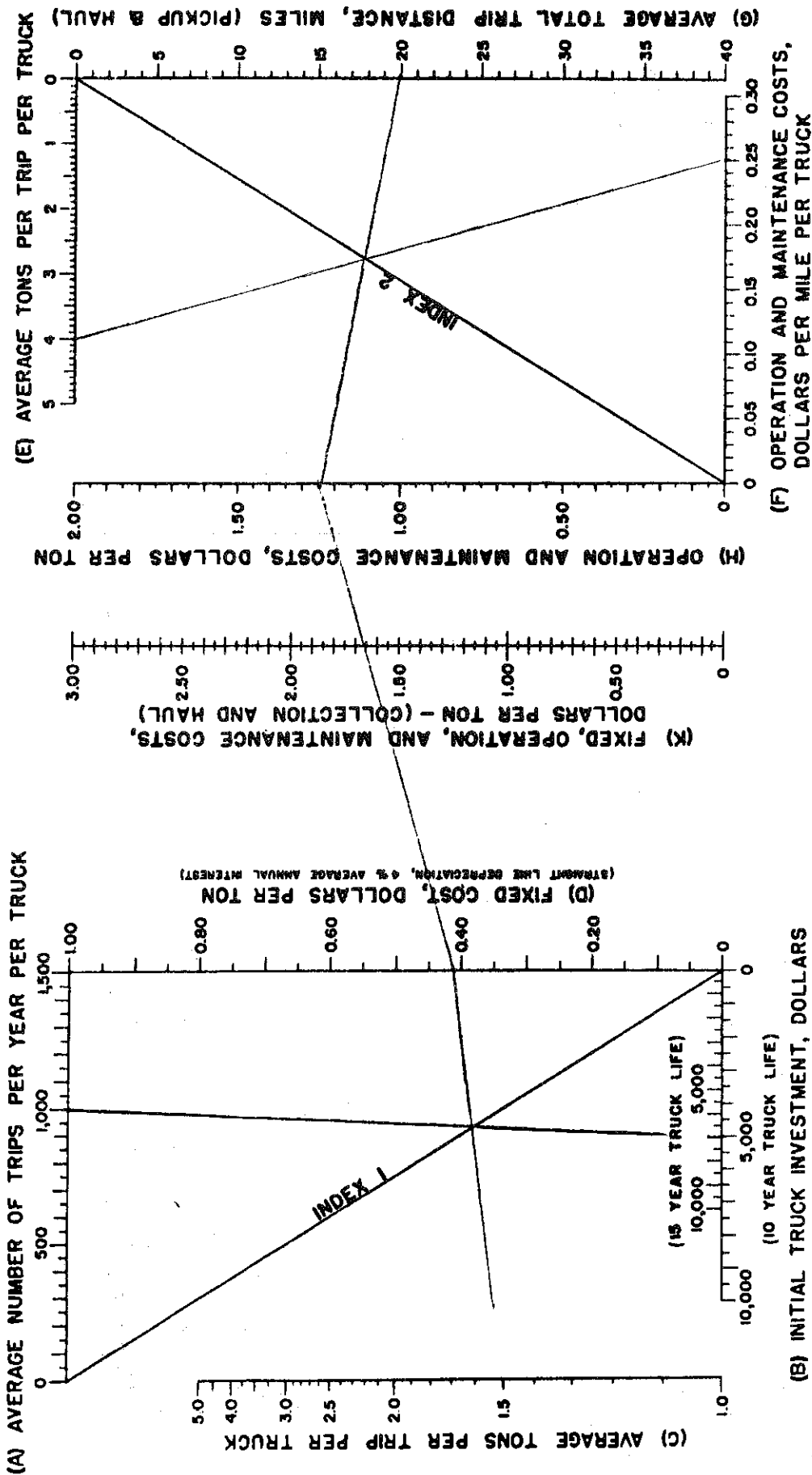

FIG. 4 - ALIGNMENT CHART FOR DETERMINATION OF BHP/100 RPM FOR ONE CYLINDER FOR NH<sub>3</sub> COMPRESSORS





**DIRECTIONS**

- (1) PLACE STRAIGHT-EDGE THROUGH APPROPRIATE VALUES ON LINES (A) AND (B). LOCATE INTERSECTION ON INDEX 1.
- (2) PLACE STRAIGHT-EDGE THROUGH APPROPRIATE VALUE ON (C) AND THROUGH INTERSECTION ON INDEX 1. LOCATE POINT ON LINE (D).
- (3) SIMILARLY, OBTAIN POINT ON LINE (H) BY USING LINES (E) AND (F), LINE (G), AND INDEX 2. PLACE STRAIGHT-EDGE THROUGH POINTS ON LINES (D) AND (H) OBTAINED ABOVE AND READ TOTAL FIXED, OPERATION, AND MAINTENANCE COSTS IN DOLLARS PER TON AT INTERSECTION ON LINE (K).

**CHART FOR DETERMINATION OF FIXED, OPERATION, AND MAINTENANCE COSTS OF REFUSE COLLECTION — DOLLARS PER TON**

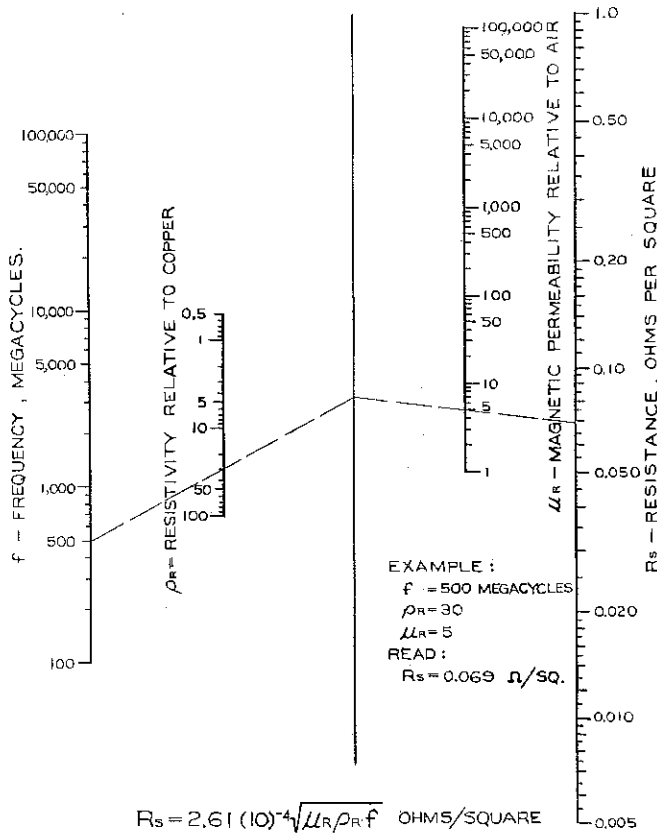

FIG. 6  
INTERNAL RESISTANCE OF PLATE SURFACES

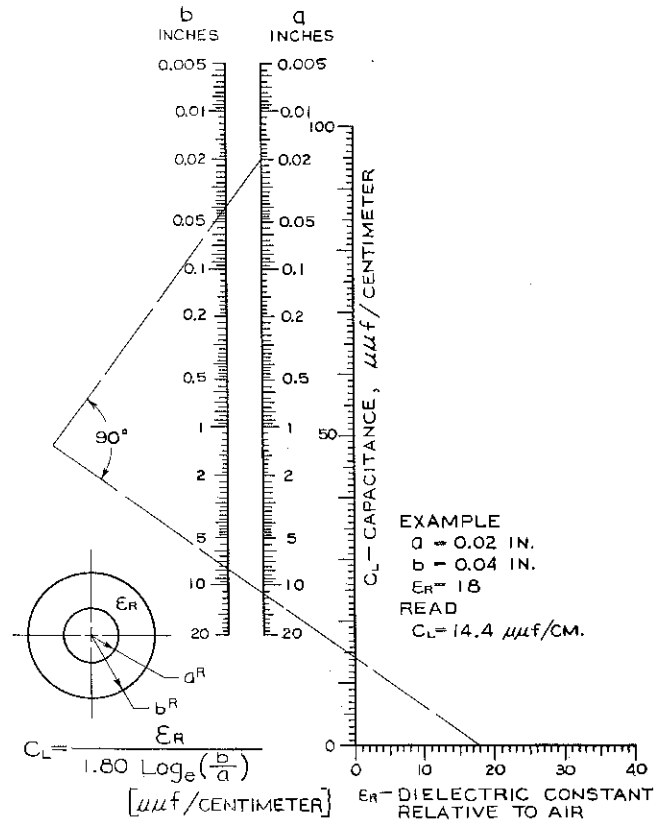

FIG. 7  
CAPACITANCE PER UNIT LENGTH OF COAXIAL CABLE

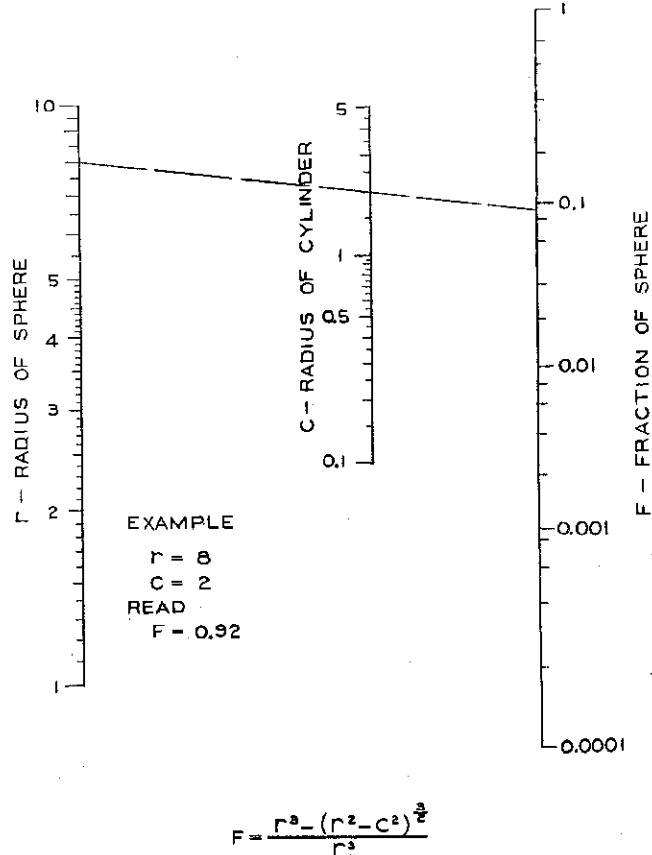

FIG. 8 FRACTION OF THE TOTAL SPHERE NOT INCLUDED IN THE CENTRAL CYLINDRICAL CORE

Assistance has also been given to graduate students. In one case an electrical engineering student profited from the use of several nomograms (Figs. 6 and 7) and another from the graphical solution of a differential equation. Recently a request for assistance was received from a University of Texas graduate student in the field of Zoology. He was in need of a nomogram that could be used in solving an equation in connection with a technique used in Cytology to measure the amount of light passing through a symmetrically shaped nucleus of a cell. The technique is called Cytophotometry. Cells are stained with a dye which reacts chemically with a cell constituent. The dye complex is localized in the nucleus, and by measuring the amount of light absorbed by the dye complex and the projected area of the nucleus in the microscope system, one can calculate the relative amount of absorbing substance present. Repeated calculations were greatly facilitated by the use of a nomogram. (Fig. 8.)

There are, in addition, opportunities for services to industry and to governmental agencies. In my work with a major aircraft company, I discovered that many engineering graduates could not effectively use the fundamentals of orthogonal projection to analyze and solve three-dimensional problems arising in aircraft design. When I inquired about their difficulty, I was informed that after they had completed their college courses in graphics they had been given practically no opportunity in the junior and senior years to apply their knowledge and experience to the analysis and solution of space problems because few, if any, had been presented. I found, for example, that many of these graduates failed to recognize that the same analysis was employed in solving a problem that dealt with the determination of the distance between two skew cables and another problem, seemingly different, the determination of the angle between two plates.

We know, of course, that similar problems arise in structural design, in transmission systems, and in frame works of various types. It is also known that the few

NOMOGRAM FOR

$$\sin \beta = \left\{ \sin \left( \tan^{-1} \frac{X}{Z} \right) \right\} \cos \alpha$$

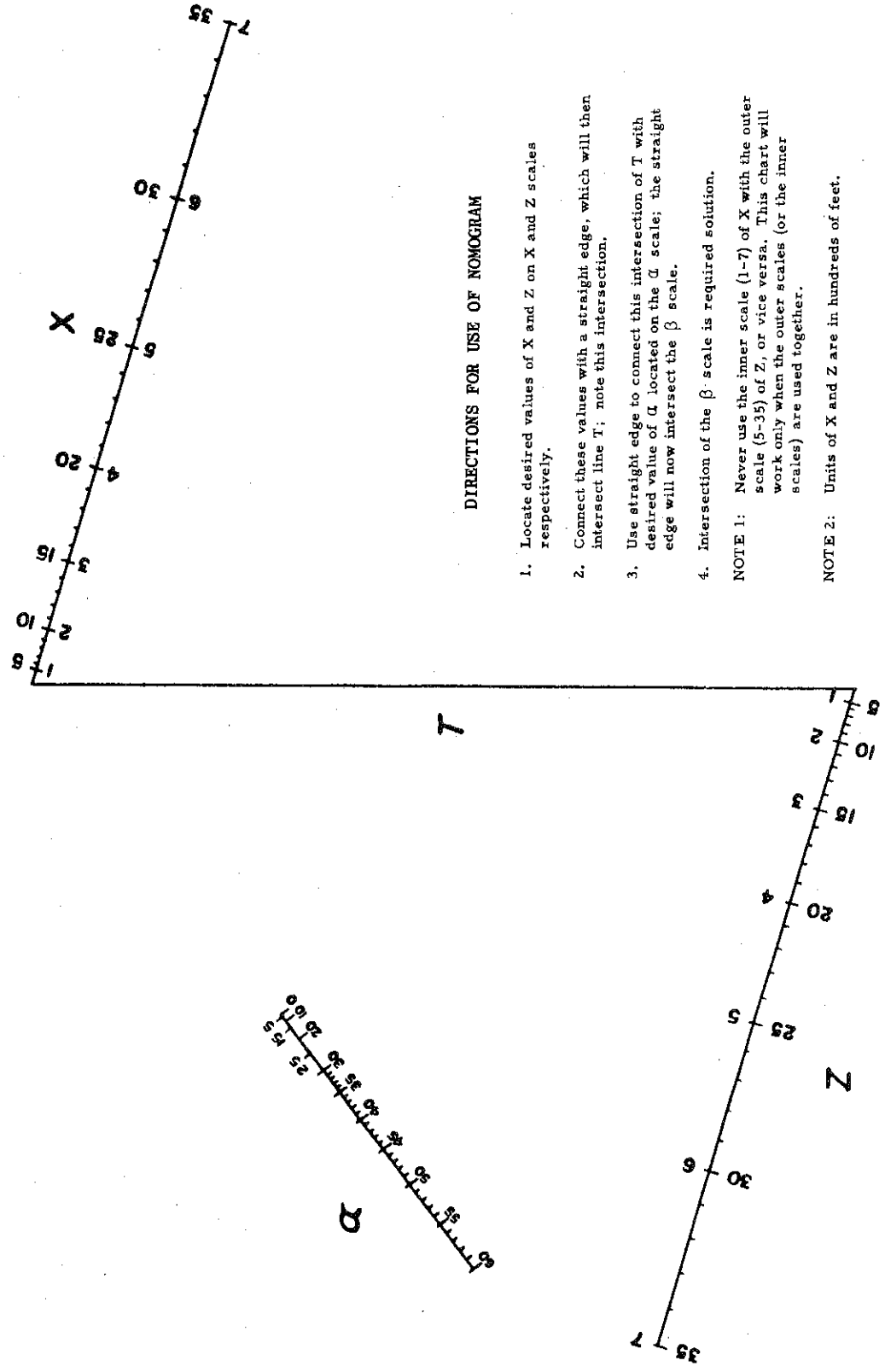
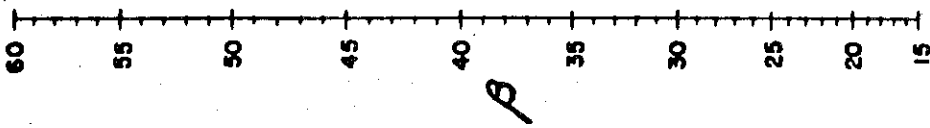

DIRECTIONS FOR USE OF NOMOGRAM

1. Locate desired values of X and Z on X and Z scales respectively.
2. Connect these values with a straight edge, which will then intersect line T; note this intersection.
3. Use straight edge to connect this intersection of T with desired value of alpha located on the alpha scale; the straight edge will now intersect the beta scale.
4. Intersection of the beta scale is required solution.

NOTE 1: Never use the inner scale (1-7) of X with the outer scale (5-35) of Z, or vice versa. This chart will work only when the outer scales (or the inner scales) are used together.

NOTE 2: Units of X and Z are in hundreds of feet.

J.R. HARVEY  
CODE 3035, 9/19/52

U.S. NCTS, INYOKERN, CALIF.  
UNCLASSIFIED

FIG. 9: BOWEN BC-2 NOMOGRAM

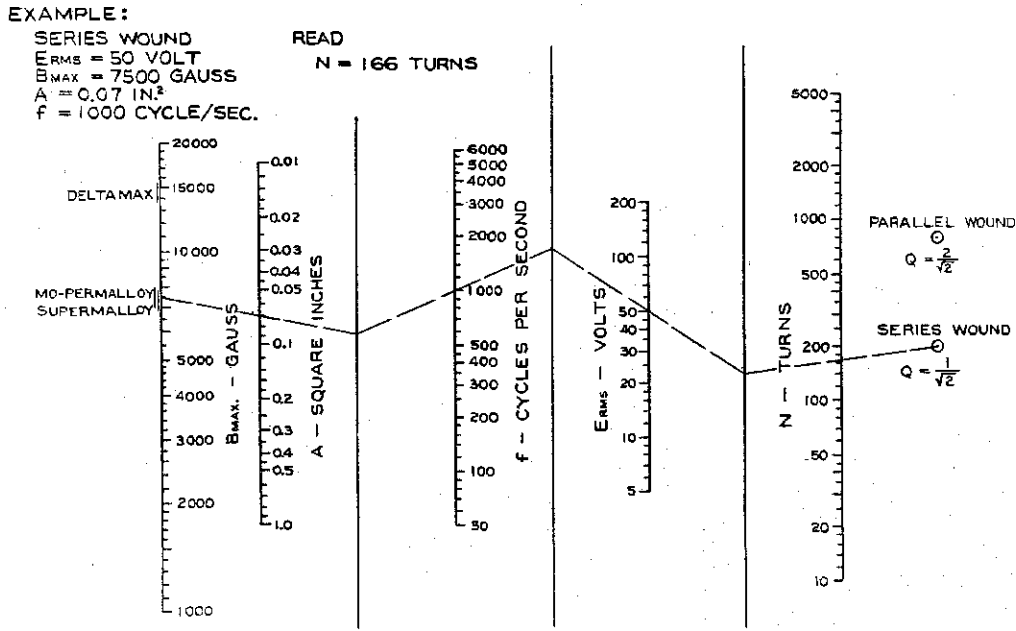

FIG. 10  
 MAG-AMP NOMOGRAM FOR SOLVING THE EQUATION  $N = \frac{10^7 E_{RMS} Q}{1.29 \pi B_{MAX} A f}$

fundamentals of orthogonal projection can be applied to the analysis of many space problems that arise in both engineering and science. It is essential, however, that our curricula, and more importantly, our faculty members provide many opportunities for effective carry-over in the use of these principles if our students are to be properly prepared to make the fullest use of their knowledge and experience.

In two cases, my experience dealt with engineering and scientific personnel associated with research, development, and design work carried on in governmental agencies. A need was felt for a working knowledge of nomography and graphical calculus. To help meet this need, a two-weeks' short course was given. This course was attended by approximately 35 selected persons who were released from their regular duties to participate in this class to the extent of five hours daily - two hours being devoted to lectures and demonstrations, and three hours to supervised computation periods. It is important to point out that the class consisted of graduates from engineering, physics, chemistry, and mathematics. I still recall the comments of one of the mathematics majors who said, "I never realized what I had missed in both my undergraduate and graduate work until I had this experience in the use of graphical methods. I now appreciate the value and usefulness of nomography and graphical methods of computation. In many instances an algebraic solution is at best, cumbersome. Not knowing the power of graphical methods of computation is a severe handicap."

Two examples of nomograms that were designed by members of this class are (a) Nomogram for Rapid

Solutions of Bowen RC-2 Camera Beta Orientation Angles, (Fig. 9) and (b) A nomogram for the repeated solution of a formula used in the design of magnetic amplifiers. (Fig. 10.) The first nomogram (Fig. 9) enables the user to make rapid determinations of orientation angles for setting a Bowen RC-2 Camera.

An interesting application of graphical integration is shown in Fig. 11. The problem is "to divide a given lot into three equal areas by lines that are perpendicular to the front edge of the lot." The graphical solution is quite accurate and very economical. Once the integral curve is drawn (a very simple matter) the ordinate, which represents the total area of the lot, is divided into three equal parts. The locations of the lines that divide the original area into three equal angles are easily obtained. This is clearly shown in the figure. If time permitted, additional examples could be cited to show the advantageous use of graphical methods in the solution of three-dimensional force problems; in the determination of displacements, velocities, acceleration<sup>1</sup>; in the plotting<sup>2</sup> of electric and other<sup>3</sup> fields that have streamline qualities; and in the detection and identification of nuclear particles.

I believe you will agree that there is ever-increasing evidence that the usefulness of nomography, graphical mathematics, and graphical methods of computation will receive more and more attention in the next few decades. It is for that very reason that we must include in our basic courses introductory phases of these fields, and, in addition, we should provide advanced courses for those students who wish to study and learn more fully of the power of graphics.

<sup>1</sup> The grapho-numerical method makes possible the determination of acceleration values directly from displacement data. See p. 483 in Graphics in Engineering and Science by A. S. Levens, Wiley, 1954.

<sup>2</sup> Field-mapping technique. See Fundamentals of Electrical Design by A. D. Moore McGraw-Hill, 1927. See also Chapter 7 in Electric and Magnetic Fields by S. S. Attwood, Wiley, 1949.

<sup>3</sup> Heat conduction, flow or air flow, without turbulence.

PROBLEM:  
TO DIVIDE PLOT ABCD INTO THREE  
LOTS OF EQUAL AREAS BY LINES  
PERPENDICULAR TO THE FRONT EDGE.

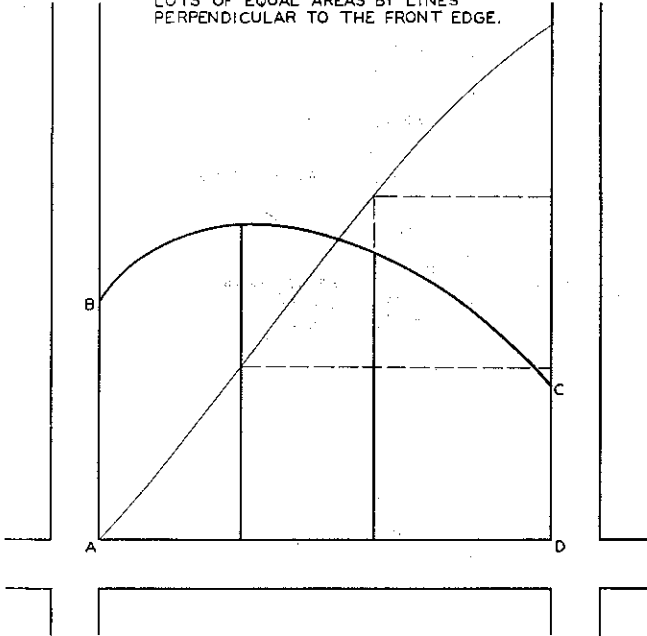

FIG. 11  
RAPID CHECK METHOD FOR  
LAND SUBDIVISION  
USING GRAPHICAL CALCULUS

In our efforts to help the student strengthen his ability in analysis - a thinking process - it is desirable to provide exercise for the student's analytical powers at every opportunity throughout his four or more years of college study, and to encourage him to record and to apply the steps in his analysis in the most coherent form, whether that form be graphical, mathematical, verbal, or a combination of the three modes of expression.

If the student is to associate his "thinking-through-the-problem" with graphics, when this association is appropriate, it is important, I believe, that he shall have training and experience in the use of graphics in the widest possible sense.

The field of graphics provides many opportunities for the student to strengthen his ability in analysis, to record his conclusion graphically, and then to employ graphical methods in solving problems.

Sufficient time must be provided for basic training in graphics - an essential field of knowledge for both engineer and scientist. Not only should emphasis be placed upon the fundamentals of projection and their application, but also considerable attention should be paid to the development of freehand sketching ability; to an understanding and knowledge of standard practices; and to an introduction of graphical solutions and computations.

This is the least we can do if we are to prepare engineering and science students to use this knowledge and experience in dealing with the challenging problems of a scientific age.

## A BRIEF SURVEY OF GRAPHIC REPRODUCTION PROCESSES

by

Professor H. P. Skamser and Professor R. L. Paul

Michigan State College

### INTRODUCTION

This article has been prepared to assist engineering educators in the choice of reproduction processes best suited to their particular requirements.<sup>1</sup> It is the hope of the authors that this material will enable engineering educators and others to decide:

- Which is the best process to use for various conditions and quantities.
- Which processes give greater legibility.
- Which are most convenient for the immediate purpose of the reader concerned.

The writers, who are not experts nor authorities, have tried to ferret out a few facts for you.

This article is not intended to cover completely all types of graphic reproduction. Relatively little emphasis is placed on letter press printing, rotogravure and similar processes. Nor does it pretend to tell the reader how to use the equipment or how to get the best results in various processes. That is left to the manufacturers,

their literature and agents, and to the individual schools or operators.

### GROWTH IN USE OF MODERN REPRODUCTION PROCESSES

Recently there has been a great growth in the use of reproduction processes by business and industry. The reasons for this are their advantages over typing carbon copies or redrawing the originals. These advantages are:

- The last copy is as good as the first, with better legibility than carbon copies.
- No manual copying is necessary.
- They save time and money.
- The accuracy in copying is absolute and all typographical errors are avoided.
- There is secrecy, if such is desired (an executive can easily run off his own copies).
- Copies may be revised or varied more easily.
- It is possible to improve on the originals.
- It is possible to produce more durable copies than by typing and the use of carbons.

<sup>1</sup> Material for this article has been compiled from interviews with representatives of the companies, experience with and examinations of machines and equipment, literature received from various manufacturers and jobbers, several previous surveys, and material prepared at the University of Nebraska. This summary was presented to the Drawing Division of ASEE during the June, 1954, meeting at the University of Illinois following the work of the Committee on Reproduction Processes: Richard S. Royster, University of Illinois; Donald N. Pierce, University of Nebraska; W. J. Luzadder, Purdue University; Ralph L. Paul, Michigan State College; and Harold P. Skamser, Chairman, Michigan State College.

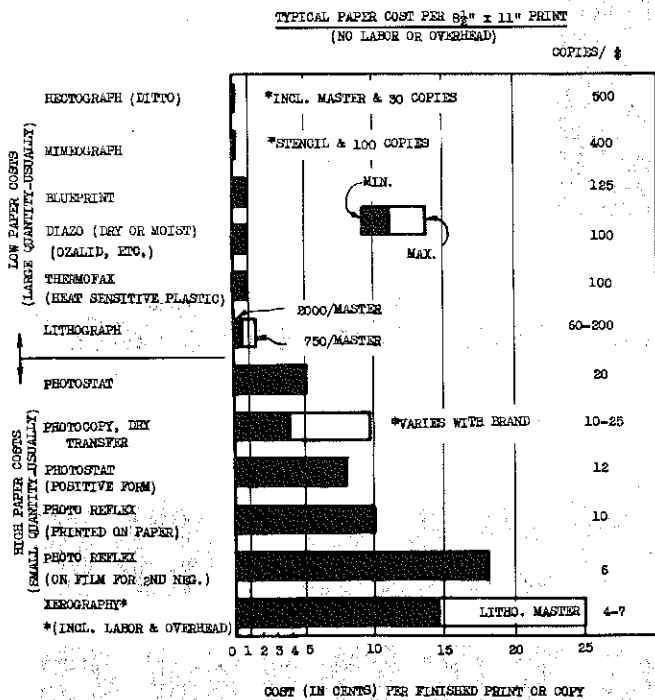

FIG. 1 PAPER COSTS

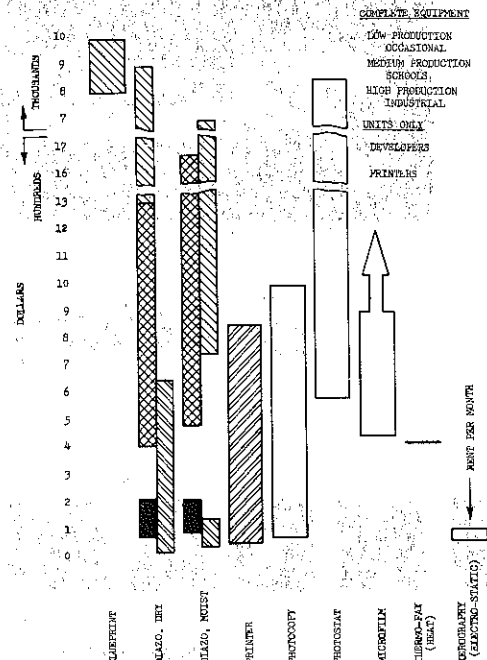

FIG. 2 EQUIPMENT COST

NOTE: PRICES ARE FOR COMPLETE EQUIPMENT EXCEPT WHEN DEVELOPERS AND PRINTERS ARE SEPARATELY INDICATED. COMPLETE EQUIPMENT MAY BE AN INTEGRATED MACHINE OR MAY BE SEPARATE PRINTERS AND DEVELOPERS PRICED AS A SET. DEVELOPERS GENERALLY ARE USABLE ONLY FOR THE PROCESS INDICATED. PRINTERS MAY BE USED FOR BLUPRINT, DRY OR MOIST DIAZO, OR PHOTOCOPY.

USES AND ADVANTAGES OF MODERN PROCESSES

Engineers, scientists and research men have three needs which can be met by modern reproduction processes: (1) to gather data (copying from bound volumes, etc.), (2) to make one or more copies of drawings, charts, tables and other data, (3) to reduce or enlarge drawings or other material so that copies can readily be stored or included in research or other reports.

Perhaps the reader is not aware of the fact that many companies now copy incoming letters (on ordinary letterhead stationery), orders, etc., with the previously mentioned advantages. Letterheads are also being printed on translucent paper to facilitate reproduction when additional copies are required by the addressee. Only a few of the most opaque letters cannot be copied by ordinary or direct processes; and they may be handled by one of the reflex or photo processes.

THE NEW TYPES

There has been an amazing growth in the use of the following new processes (for publications, theses, research reports, etc.) because in many cases they eliminate the necessity of making an ink drawing or tracing, or doing any manual copying.

1. Modern Photo-Copy (transfer) process.
2. Radiant heat energy process (Thermo-Fax), which forms an image by melting a plastic.
3. Electro-static and plastic process (Xerox).
4. A diazo coated "Reflex film" which permits copying from opaque sheets with the aid of a blueprint machine or other printer, and moist development. This film becomes a second original (or intermediate).

THE FABULOUS PHOTO-TRANSFER METHOD

The Apeco Auto-Stat was the first of the new photo-copy (transfer) processes and was on the market a year and a half before others followed. The Apeco requires no warm-up. Incandescent lights do not interfere with its operation. However, blue fluorescent tubes or daylight causes fogging and prevents satisfactory operation.

The first step in any photo-copy (transfer) process such as "Dri-Stat" is exposure or printing and it is essentially the same as the first step in blueprinting or diazo (ozalid, etc.). The coated sheet has a silver compound which is altered when exposed to light. This sheet is used as a matrix (or negative) to make one or more copies in a one-step developer and contact print operation. The unaltered silver compound on the matrix is transferred to the final sheet in the image of the original. This transfer is due to an affinity of the coating on the positive print sheet for the unaltered silver compound on the matrix (or negative). Some brands will transfer to an uncoated sheet.

The Photostat Company's "Instant Copier" is essentially the same as the Verifax machine and the developing solution must be warmed up before proceeding. Other Photo-Copy (transfer) process names are: Contoura, Portograph, Transcopy, Dupliomat, Photorapid, CoPease, Exact Photo-Copy.

FEATURES COMMON TO PHOTO-COPY (TRANSFER) PROCESSES USED IN OFFICES AND ENGINEERING

1. They can copy from opaque, translucent or transparent sheets (can even copy incoming mail).
2. They are best suited for a few copies, from 1 to 15.
3. They are limited to smaller sizes. Some makes such as the "Dri-Stat" by Peerless permit 12 to 18 inch width and indefinite lengths. They are generally table-top models (usually portable) which take up little more space than a typewriter.
4. Cost.
  - a. Materials cost 5 to 10 cents for each 8-1/2 x 11 copy.
  - b. Equipment costs \$50.00 to \$500.00 and up. The more expensive versions are automatic, power driven or handle larger than 8-1/2 x 11 sizes.
5. There is some doubt about the permanence of dri-developed copies although manufacturers claim they are permanent. The process is so new that no one knows for sure.



*Completely Revised and Up-to-Date!*

# FUNDAMENTALS OF ENGINEERING DRAWING

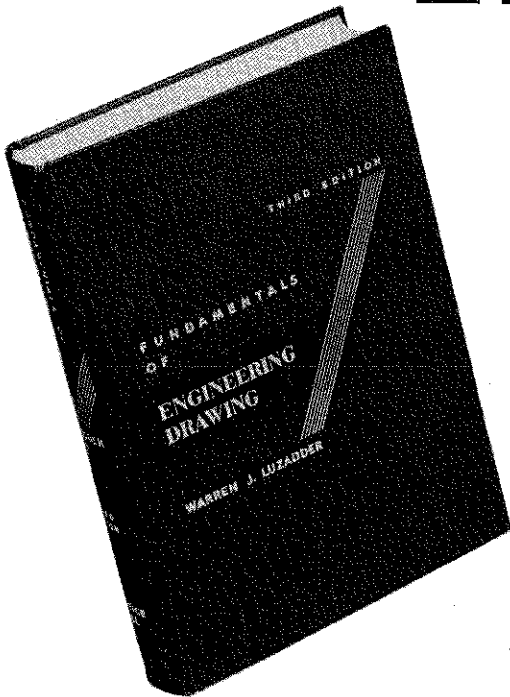

Third Edition

by Warren J. Luzadder, Purdue University

---

**H**ERE is a truly up-to-date text with tables, problems and illustrations based on the new British-American Unified Screw Thread.

You will find this book is written so that you can spend your time teaching fundamental principles instead of answering scores of questions on details. Professor Luzadder constantly keeps in mind the students and the questions they usually ask. Consequently, students are always able to find an understandable illustration with a simple explanation for any difficult detail they may encounter.



## HIGHLIGHTS OF THE NEW EDITION

- Many more new assembly drawings from which students may make drawings of individual parts.
- Shaded pictorial drawings present the rotated parts of the mechanism. Students working problems designed about these drawings must do some reasoning to produce a correctly finished work.
- All new "part" problems show adjacent parts so students can understand the function of the assigned part in a mechanism. For students the problem has much more significance and the part is not an unrecognizable piece.
- Brand new chapters on Architectural Drawing (chapter 23) and Graphical Calculus (chapter 29).
- Expanded coverage of Engineering Geometry, Dimensioning, Auxiliary Views, and Structural Drawing.
- Many new and practical problems — particularly in the chapter on Working Drawings (chapter 19).
- Students use the new drafting standards of the American Standards Association, plus the existing standards of the Association and The Society of Automotive Engineers.

721 pages 6" x 9"

## PROBLEMS IN ENGINEERING DRAWING

3rd Edition

These 71 up-to-date worksheets were designed as a companion to the text. They are, however, adaptable to any standard text on engineering drawing and offer valuable follow-through to regular text work. The problems are in the form of partial layouts on manila-type drafting, graph, and regular bond paper. The sheets are loose, inserted in a heavy envelope with a booklet of instructions, and punched for keeping in a binder.

## TABLE OF CONTENTS

1. Introduction
2. Drawing Materials and Equipment
3. Use of Instruments and Equipment
4. Engineering Geometry
5. Technical Lettering
6. The Theory of Projection
7. Multiview Drawing
8. Auxiliary Views
9. Revolution
10. Sectional Views
11. Conventional Practices and Representations in Orthographic Drawing
12. Freehand Drawing
13. Ink Work and Tracing
14. Pictorial Drawing
15. Shop Processes
16. Dimensioning
17. Screw Threads and Fasteners
18. Piping Drawings
19. Working Drawings
20. Welding Drawings
21. Machine Elements
22. Developments and Intersections
23. Architectural Drawing
24. Structural Drawing
25. Topographic and Engineering Map Drawing
26. Shade Lining and Surface Shading
27. Patent Office Drawings
28. Reproduction and Duplication of Engineering Drawings
29. Engineering Graphs and Charts. Graphical Calculus.

Appendix • 721 Pages  
6" x 9" • Illustrated

*For approval copies write*



**PRENTICE-HALL, Inc.** 70 FIFTH AVENUE, NEW YORK 11, N. Y.

*Books of all Publishers*

ON

**ENGINEERING  
HIGHER MATHEMATICS  
& RELATED SUBJECTS**

A most complete and comprehensive collection  
of books in the field

*For any book ever published*

**USED OR NEW - CURRENT  
OUT-OF-PRINT**

*Come \* Write \* Phone*

One of the world's largest bookstores

**BARNES & NOBLE, Inc. - Publishers**

105 FIFTH AVE.

NEW YORK 3, N. Y.

ALgonquin 5-1420

(Continued from page 33)

6. Not much skill is needed and no installation (just plug into 110 volt line).
7. They can be used in ordinary room light because they use a slower, less sensitive photo paper. Fluorescent lamps and sunlight fog the negative. One can print on both sides of final copies with some brands.

OTHER NEW PROCESSES

1. The Thermo-fax process uses a plastic coated sheet which is placed in contact with an original and exposed to heat rays. Some of the dark plastic melts through to the face of the coated sheet and a duplicate of the original is produced in one step.
2. Xerox takes a picture of the original on a selenium coated and electrostatically charged metal plate. A plastic is cascaded over the surface and adheres to areas which are a duplicate of the original image. This plastic is then transferred to a paper sheet by electrical attraction, and the plastic baked onto the surface. This may be a final copy, or a lithograph master. Halftones are possible.
3. Bruning's Diazo coated "Reflex Film" permits light to pass through a fine plastic screen on the film. This light is reflected from the light areas of the opaque original onto a diazo coating on the film face adjacent to the original. The screen is peeled off and a moist diazo developer used. This results in a second original or intermediate on transparent film.

COMMON FEATURES OF ALL PROCESSES

Almost all graphical reproduction processes, except letter press printing, etc., have certain features that are common; i.e., exposure to a form of wave energy such as light, heat or electricity. Most processes will reproduce or copy on several types of material, such as opaque, translucent or transparent papers cloths or foils (plastic). Cloth, glass or metal may be coated and used in the standard photographic process. The chief differences in the various processes are in the coating material and energy (wave) form used to effect the change which produces the copy. Time, labor and costs vary greatly too.

There are some types of machines on which several of the processes can be used. Printers (using light as the energy form, Fig. 2) common in colleges and blueprint departments of industry, may be used for blueprints, whiteprints, VanDykes, Diazos (ozalid, etc.), and for the new photo transfer process. They can copy from translucent, transparent and opaque originals. The only variation is in the surface coating and the composition of the developer.

CLARIFICATION OF TERMS

DRY PROCESSES

Ammonia developed Diazo  
Thermofax  
Xerox

MOIST PROCESSES

Fluid developed Diazo  
Photo-copy (transfer)  
(called Dry by Mfgs.)  
Hectograph (Ditto)  
Mimeograph

WET PROCESSES

Blueprint, VanDyke, Blueline  
Standard photo processes  
(Contact print, photostat)  
(Microfilm, reflex prints)

The dry processes are usually simpler, involving one step development and requiring no plumbing. Venting is usually required for ammonia type (Dry Diazo) equipment. The moist processes also use one step development and simple equipment, but they do require some moisture contacting the surface of the final print. Prints dry quickly (a minute or so) without drying equipment. The wet processes require elaborate or cumbersome equipment, plumbing and drying equipment installations.

NEGATIVES

<u>Dark Background</u>	<u>Reverse</u>
<u>Light Image</u>	<u>Reading</u>
Blueprint	
VanDyke	VanDyke
Microfilm	Microfilm
Photo-negative	Photo-negative
Matrix (photocopy)	Matrix (photocopy)
Photostat	

POSITIVES

<u>Dark Image on</u>	<u>Right Reading</u>
<u>Light Background</u>	<u>(not reversed)</u>
Blueline	} All Those at Left
Diazo	
Thermofax	
Xerox	
Photocopy (transfer)	
Standard Photo	
Photostat	
Hectograph (Ditto)	
Mimeograph	

MAJOR TYPES

There are six major types of reproduction which use some form of wave energy. These are:

1. The iron compound group such as blueprint.
2. The iron and silver group such as the VanDyke and Brownprint.
3. The Diazo dye group (Ozalid, Driprint, etc.).
4. Silver compound or photographic types.
  - a. Photo-copy (transfer) quick developed (Ansco Patent)
  - b. Standard photo processes
5. Electro-static and plastic (Xerox).
6. The radiant heat and plastic (Thermofax).

Other major reproduction processes which do not involve wave energy directly are mimeograph, ditto, printing, lithography, etc.

VARIATIONS

Processes vary in quality and in the amount of skill required from the blueprint (iron compound) mimeograph and ditto types which do not have a very high quality in definition and detail and require a low amount of skill; to the standard photographic (silver compound) processes at the other extreme which may produce a high quality and require considerable skill.

Some processes are extremely sensitive to light. A darkroom or great care must be used. Others can be exposed to considerable room light without any damage.

Permanence of the copies depends upon two factors; the type of process and the material (paper, cloth, foil or metal) on which the copy is reproduced. Silver compounds in ordinary photo processes are among the most permanent.

UNIQUE FEATURES

The Ditto process is unique in the ease with which several colors can be produced from one "Master." By

PROCESS FEATURES <sup>4</sup>	NUMBER OF STEPS REQUIRED IN SEVERAL TYPES OF REPRODUCTION PROCESSES										
	BLUEPRINT	DIAZO, DRY	DIAZO, WET	PHOTOCOPY	PHOTOSTAT	MICROFILM	THERMO-FAX	XEROGRAPHY	MIMEOGRAPH	HECTOGRAPH	
WILL COPY FROM											
TRANSPARENT	X	X	X	X	X	X	X	X			
TRANSLUCENT	X	X	X	X	X	X	X	X			
OPAQUE (1 OR 2 SIDES)			X	X	X	X	X	X			
STENCILS OR MASTERS									X	X	
BOUND BOOK			X	X	X	X					
WILL COPY ON											
PAPER <sup>1,3</sup>	X	X	X	X	X		X	X	X	X	
CLOTH <sup>1,3</sup>	X	X	X	X							
FILM (FOIL) <sup>2,3</sup>	X	X	X	X		X					
METAL	X										
NON-SENSITIZED PAPER				X				X	X	X	
TWO SIDES		X		X				X	X	X	
PRE-PRINTED FORMS				X				X	X	X	
SPECIALTIES		X	X	X							
ALTERATIONS BY											
ERADICATORS		X	X	X							
CUT-OUTS		X	X	X				X		X	
OVERLAYS	X	X	X	X	X	X					
MASKING	X	X	X	X	X					X	
TYPING OR DRAWING		X	X	X							
COLOR											
PAPER	1	4	4	1	1	1	1	1	6	6	
IMAGE - ONE COLOR/PRINT	1	4	4	1	1	1	1	1	10	5	
IMAGE - MULTI-COLOR											X
NEGATIVE FINAL COPY	X				X	X					
POSITIVE FINAL COPY	X	X	X	X	X	X	X	X	X	X	
ENLARGEMENT OR REDUCTION					X	X		X			
SUBURBAN ROOM LIGHT REQ'D				X							
NORMAL ROOM LIGHT OK	X	X	X	X	X	X	X	X	X	X	
QUANTITY RANGES <sup>5</sup>	1-100	1-100	1-100	1-15	1-15	1-15	1-15	1-15	10-1000-500		

(1) PAPERS AND CLOTHS MAY BE OPAQUE OR TRANSLUCENT.  
 (2) FILMS MAY BE TRANSPARENT OR TRANSLUCENT.  
 (3) TRANSPARENT OR TRANSLUCENT COPIES MAY BE USED AS SECOND ORIGINALS.  
 (4) FEATURES INDICATED MAY NOT BE FOUND IN ALL EQUIPMENT IN A GIVEN CLASS.  
 (5) QUANTITIES LISTED ARE ARBITRARY BUT GIVE AN IDEA OF THE ECONOMICAL RANGE FOR WHICH THE PROCESS WAS DESIGNED.

FIG. 3 VERSATILITY

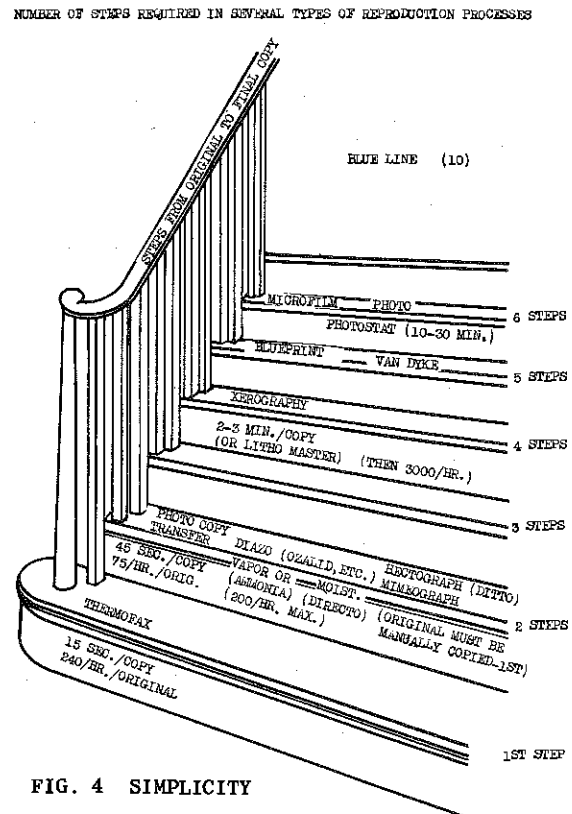

FIG. 4 SIMPLICITY

changing the color of the Ditto "carbon" which backs up the Ditto Master, any portion may be made in any of several colors. There is no problem of alignment or overlap because all colors appear on the one Master. In a number of schools students draw directly on the Ditto and Mimeograph copies which are set up as sketch or test problems. They are also used as a means of presenting drawing problems.

Contoura, one of the least expensive Photo-copy (transfer) processes, can be carried in a briefcase and will copy from bound volumes anywhere a 110 volt light is available. Other equipment for copying from bound books is not readily portable and the bound volumes are usually brought to the machine.

The following processes are generally limited to smaller sizes or widths (8-1/2" x 11" to a maximum width of 18"): Hectograph, or ditto, mimeograph, Photocopy (transfer-quick developer), Thermofax, Xerography, lithograph for schools and, portable or semi-portable table-top Diazo.

**CONCLUSION**

The second part of this article (to appear in a later issue) will give details about specific processes and trade names, and indicate the chief uses of the various processes.

The reader who is interested in a specific phase of graphic reproduction may consult the literature of the various manufacturers and distributors. Further information or names and addresses of manufacturers may be obtained from the authors.

**JOURNAL OF ENGINEERING DRAWING**

Published by  
 DIVISION OF ENGINEERING DRAWING  
 AMERICAN SOCIETY FOR ENGINEERING EDUCATION

**PUBLICATION COMMITTEE**

- Editor . . . . . Warren J. Luzadder  
Purdue University,  
West Lafayette, Indiana
- Advertising Manager . . . Harold B. Howe  
Rensselaer Polytechnic Institute,  
Troy, New York
- Cir. Mgr. and Treasurer. Edward M. Griswold,  
The Cooper Union,  
Cooper Square,  
New York 3, New York

PUBLISHED . . . . . FEBRUARY, MAY, NOVEMBER

Annual Subscription Price . . \$1.25  
 Single Copy . . . . . \$0.45

**EDITORIAL STAFF**

- Irwin Wladaver . . . . . New York University
- J. Norman Arnold . . . . . Purdue University

**CARTOONIST**

- R. C. Carpenter . . . . . Purdue University

Published in the Interest of Teachers and Others  
 Interested in Engineering Graphics

# Breaking through the Resistant Crust



Photo courtesy  
Monsanto Chemical Company

*In the man's hands is the equivalent in Krilium of pile of compost between man and boy. Krilium is not subject to bacterial attack, lasts much longer.*

Clayey soil packs hard, resists tillage, kills seedlings and keeps life-giving water and air from penetrating the surface. The Monsanto Chemical Company has developed a chemical which causes resistant clay to "open" up and become fertile and tractable. This "Krilium" may be one answer to the world's demand for more productive land.

In some men you sense a resistance that is like nothing in the world so much as hard-packed, barren and unproductive earth. With some men, perhaps it is too late. But with boys in their early teens, habits have not hardened and every educator owes it to the boy, to himself, and to society to apply some aerating and softening influence so that the native fertility and productivity in every boy can break through.

Surely educational theory agrees the lad's interest must be pulled beyond himself so that the back and forth traffic set up can increasingly get through. Certainly educators agree enthusiasm must be focused on something bigger, better and beyond the lad's own petty ego. Certainly in mechanical drafting there is golden opportunity not only in a new class, a new subject, but in

the fact the boy is linking brain and hands in a task that is the first step on a road that can lead to the self-transcending goals of engineering, scientific and other creative contribution . . . with good to the world, with honor, prestige and appreciation to the giver.

What better can anybody ask? And why run the risk of contradicting all the influences brought here to bear, by permitting indifference in the selection of the drafting tools with which the boy will work? Certainly the concept of the value to boy and environment alike is worth far more than the petty economy to be gained by cheap and worthless tools.

## EUGENE DIETZGEN CO.

Chicago • New York • San Francisco • New Orleans • Los Angeles  
Pittsburgh • Washington • Philadelphia • Milwaukee  
*Dealers in All Principal Cities*



# DIETZGEN

EVERYTHING FOR DRAFTING  
SURVEYING AND PRINT-MAKING

AD 55-1811

# ENGINEERING DRAWING

By JOSEF V. LOMBARDO, Queens College;  
LEWIS O. JOHNSON, New York University;  
W. IRWIN SHORT, University of Pittsburgh;  
ALBERT J. LOMBARDO, Otis Elevator Co.

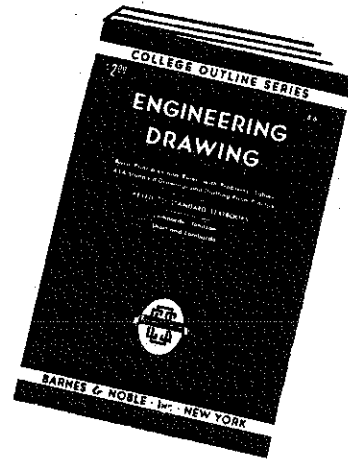

**\$2.00**  
Paper

## AN OUTSTANDING NEW TEXT AND REVIEW BOOK

Basic Principles and Rules; Problems; Tables; ASA Standard Drawings and Drafting Room Practice.

432 pages

*Keyed to Standard Textbooks*

60 pages of problems taken from shop practice require the student to apply theories and professional standards of work.

More than 500 expertly prepared drawings illustrate the text.

The most recent complete edition of **AMERICAN STANDARDS AND DRAFTING ROOM PRACTICE** is included, together with many reference tables.

Numerous suggestions for the simplification of drawings reflect the modern trend toward economy and efficiency.

An excellent book to use either as an adopted text or as a comprehensive review book.  
INSTRUCTORS ARE OFFERED A FREE EXAMINATION COPY ON REQUEST.

### Other Titles in Barnes & Noble COLLEGE OUTLINE SERIES of Interest to Engineering Students:

ANALYTIC GEOMETRY, \$1.25  
CALCULUS, \$1.25  
COLLEGE ALGEBRA, \$1.00  
FIRST YEAR COLLEGE PHYSICS, \$1.00  
LOGARITHMIC & TRIGONOMETRIC  
TABLES, \$0.75

PHYSICS WITHOUT MATHEMATICS,  
\$1.25  
PRACTICAL USE OF THE SLIDE RULE,  
\$1.00  
PRINCIPLES OF GEOLOGY, \$1.25  
PROBLEMS IN PLANE GEOMETRY, \$1.25

ON SALE AT YOUR BOOKSTORE

**BARNES & NOBLE, Inc.** - Publishers  
105 FIFTH AVE. NEW YORK 3, N. Y.

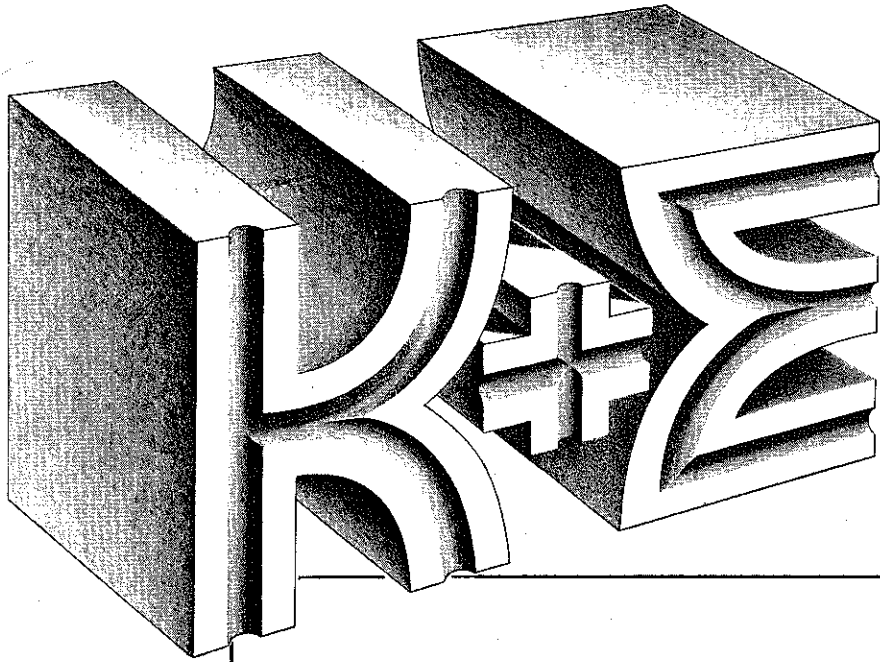

Draftsmen, engineers, designers, architects, looking for quality and reliability, have recognized K&E leadership for 87 years. That is why K&E is their first choice for the tools and materials they work with.

The same K&E leadership, so long a tradition with the professionals, is just as important for students as well.

Whatever the student's needs may be, he will find that K&E offers the right drafting instruments and materials that he is looking for—right in quality and right in price.

## **KEUFFEL & ESSER CO.**

EST. 1867

*Drafting, Surveying, Reproduction Equipment and  
Materials • Slide Rules • Measuring Tapes*

NEW YORK • HOBOKEN, N. J.

CHICAGO • ST. LOUIS • DETROIT • SAN FRANCISCO  
LOS ANGELES • MONTREAL

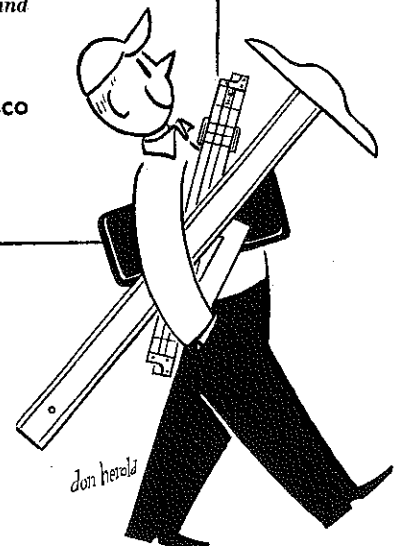



# FREE School Catalog

SPECIAL SCHOOL CATALOG

## VEMCO

### Steel Drawing Instruments

ENGINEERED FOR HEAVY-DUTY PENCIL DRAWING

*All-Steel, Open-Truss construction gives Strength, Rigidity & Light Weight*

**"OPEN-TRUSS" DESIGN**  
cuts weight 40%,  
Increases  
Strength, Rigidity

**STEEL "C-SPRING"**  
Exerts constant Pressure,  
Prevents Play

**"4-POINT CONTACT"**  
Insures Alignment

**STEEL CENTER SCREW**  
engages  
**STEEL CYLINDRICAL NUTS**

**STEEL THREADED PARTS**  
Insure long life.

**STEEL LEGS**

Heavy pressures, for reproducible pencil drawings, require strength. Accurate fine lines in design problems require rigidity. Both strength and rigidity are imperative for the "heavy-duty" demands of modern drafting-room practice.

**Make this "Twist Test" on the compass you buy**

Draw black circles one-half inch in diameter with hard lead in compass, applying heavy twisting pressure. The legs must not twist.

**Three Price Ranges**

SCHOOL GRADE (Yellow Dot)	COLLEGE GRADE (Red Dot)	PROFESSIONAL GRADE (Blue Dot)
Nickel-plated on machine-finished cold-rolled steel. Exactly same design as for higher-priced instruments. Inexpensive. Especially suitable for secondary school use.	Chrome-plated cold-rolled steel instruments with small parts in bright chrome or stainless steel. Hand-finished. Guaranteed. Used by high schools and colleges.	Hand-finished stainless steel instruments for the discriminating draftsman who demands the finest in appearance under severe service. Guaranteed.

U. S. Patents  
2,277,999, 2,222,002  
D-133497, D-130598, D-135138

Illustrates how use of Vemco Steel Instruments enables schools to

## SAVE 32%

Write for your free copy today,  
**V. & E. MANUFACTURING CO.**

P.O. Box 950M

Pasadena 20, Calif.

you can use **WILCOX** with more than **30** instruments

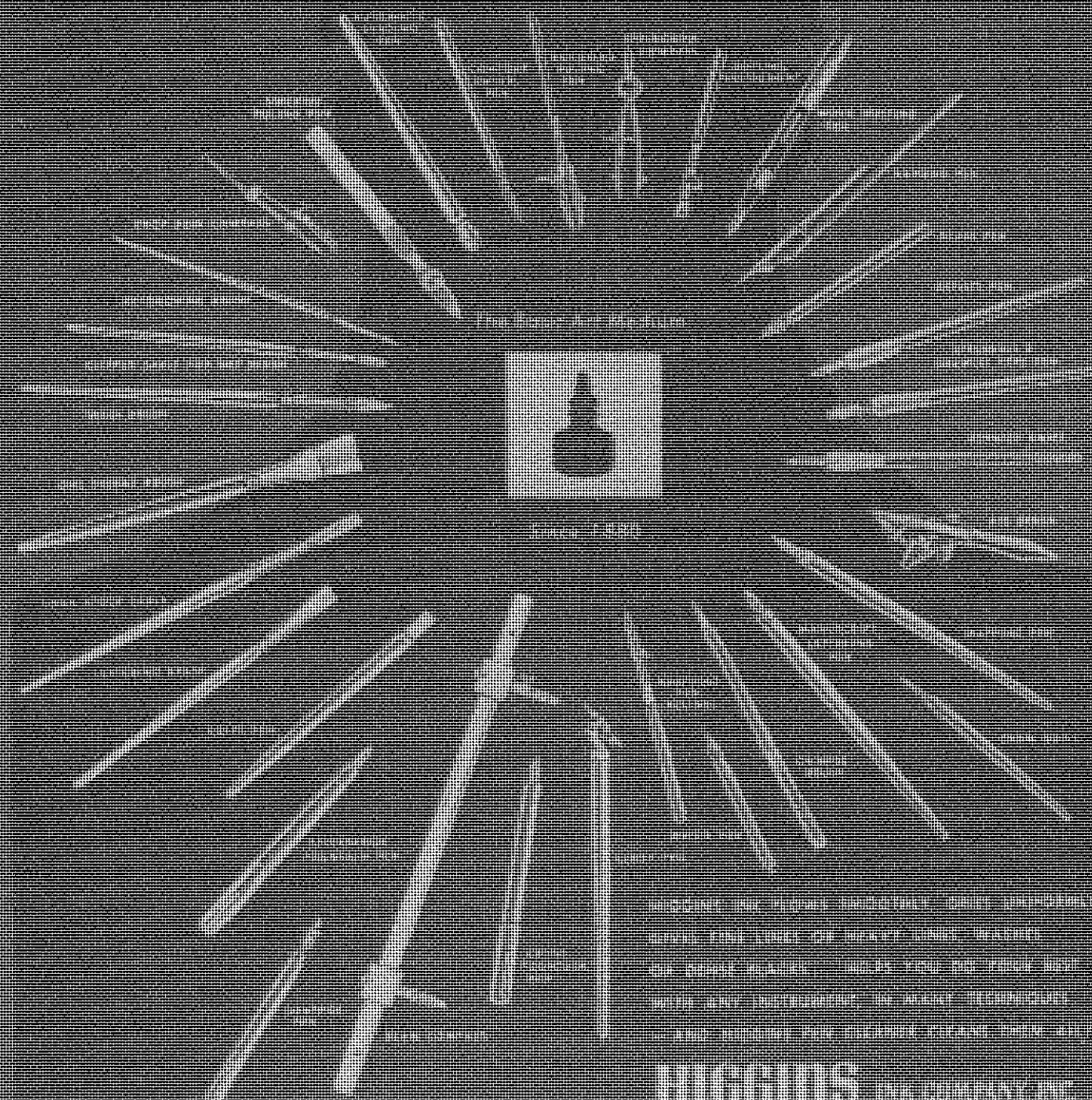

**WILCOX INSTRUMENTS COMPANY, INC.**  
ORIGINALLY NEW YORK

announcing  
 the publication  
 of the  
 new 1954  
 edition of

# OPERATION CRAFTSMANSHIP II

... the most comprehensive  
 catalogue of German  
 drawing instruments ever  
 published, featuring  
 the famous



CUSTOM QUALITY  
 IMPORTED GERMAN  
 DRAWING INSTRUMENTS

and the



a variety of top quality  
 imported German instruments  
 and sets for every possible  
 need, in a wide and popular  
 range of prices.

**GRAMERCY IMPORT  
 COMPANY, INC.**

6 State Street — New York 6, N. Y.

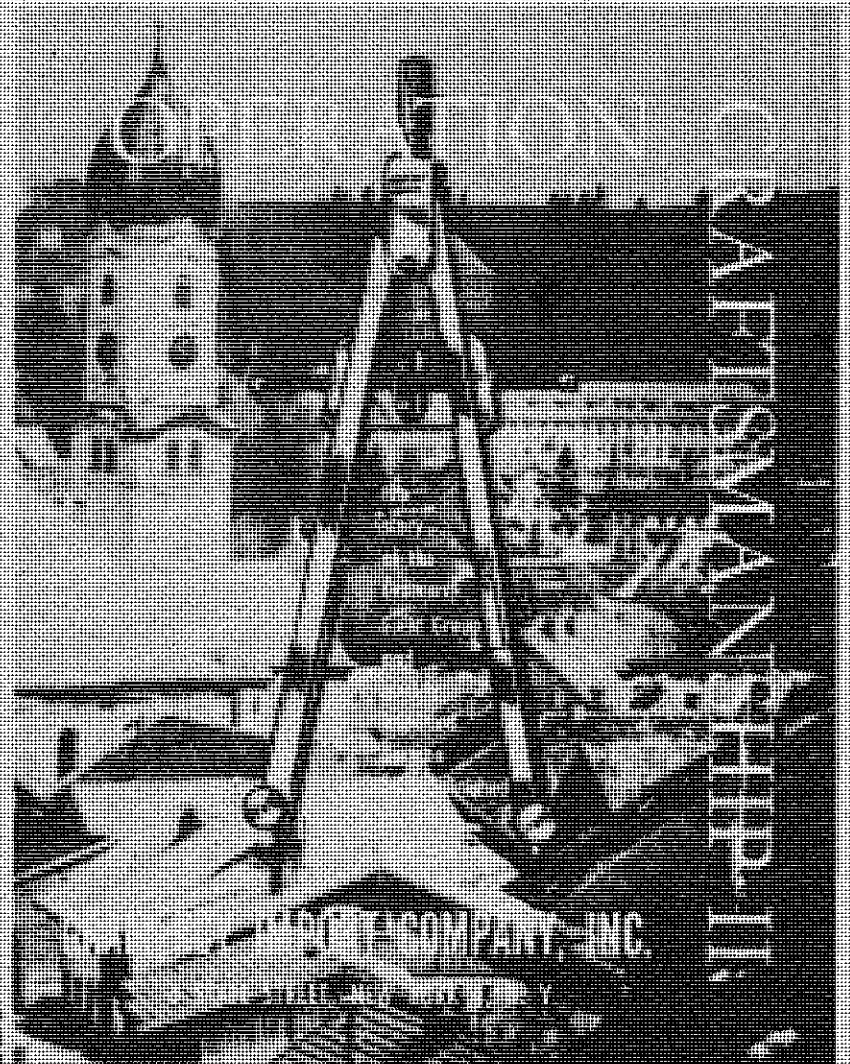

GRAMERCY IMPORT COMPANY, INC.  
 6 State Street, New York 6, N. Y.

Please send me, without charge or obligation, a  
 copy of the new edition of Operation Craft-  
 smanship II.

Name \_\_\_\_\_

Address \_\_\_\_\_

Address \_\_\_\_\_

CITY & STATE \_\_\_\_\_