

Wind Turbine Blade CAD Models used as Scaffolding Technique to Teach Design Engineers

John Irwin
Michigan Technological University

Abstract

The Siemens PLM CAD software NX is commonly used for designing mechanical systems, and in complex systems such as the emerging area of wind power, the ability to have a model controlled by design parameters is a certain advantage. Formula driven expressions based on the amount of available wind in an area can drive the amount of effective surface area of a lift type blade, and therefore drive the shape and size of the system. NX allows the user to insert expressions into the model to resize the shape of the model based on these formulas. Introducing future design engineers to this methodology using scaffolding techniques can encourage them to optimize the usability of a CAD model. This paper introduces the methodology of designing Darrieus style blades for vertical and horizontal residential wind turbines that is used to illustrate to students the capability of creating a formula driven solid model. This methodology can be used to create any mechanical system that may need updates depending on user needs driven by a formula, which in this case is the amount of power output in certain wind conditions (Irwin, 2011). The scaffolding instructional technique has resulted in several successful student projects that have implemented expression driven parametric assembly models.

Introduction

The initial NX CAD models created for the two wind turbines discussed in this paper were modeled by Mechanical Engineering Technology (MET) students as part of their undergraduate senior projects in fall 2008 and spring 2009. Each senior project team explored the advantages and disadvantages of both the horizontal and vertical axis wind turbine (HAWT and VAWT) blade designs in terms of manufacturing and performance.

During the fall of 2009 the NX CAD models were manipulated by the author to develop parametric links between mated parts in the assemblies and user expressions were added in the form of mathematical formulas giving the ability to drive design characteristics. The NX CAD model preparation and modifications were proven to provide additional capabilities of utilizing expressions as a design tool (Irwin, 2009). Subsequently, the wind turbine models have been used as a teaching tool to encourage similar applications of utilizing expressions in CAD design modeling for senior capstone projects.

According to John Dewey (1938) in the constructivist philosophy the student should be active in learning by constructing his own conceptualizations and finding his own solutions to problems and the teacher takes more of a mentoring role. Scaffolding is a method of mentoring students along the path of finding solutions to problems.

Scaffolding can be used to provide students a real world example of a new technique or concept to stretch their ability to believe in themselves that accomplishing that goal is within their grasp. This technique often involves adjusting the support offered during a teaching session to fit the student's current level of performance (Powell & Kalina, 2009). To model this scaffolding technique, tidbits for utilizing expressions in CAD models are introduced throughout the design engineering curriculum using the wind turbine CAD model as an example.

The use of expressions in a 3D CAD model for driving design intent is a popular concept described by several authors such as Samuel (2010), but the advantages in a design environment to drive an entire assembly utilizing design parameters may be something that is often overlooked by the designer or not implemented because of time constraints or lack of knowledge to implement properly.

HAWT Hugh Piggott Blade Design

A general overview of the technical aspects of wind turbine design and model development is necessary to grasp the advantage of teaching the use of expressions in this context. The Michigan Tech MET fall 2008 undergraduate senior project design team modeled their HAWT turbine after the Hugh Piggott design (see Figure 1) described in the publication, "How to Build a Wind Turbine", which outlines designs for 4 foot, 8 foot, and 12 foot diameter blades and corresponding alternators for residential use (Piggott, 2005).

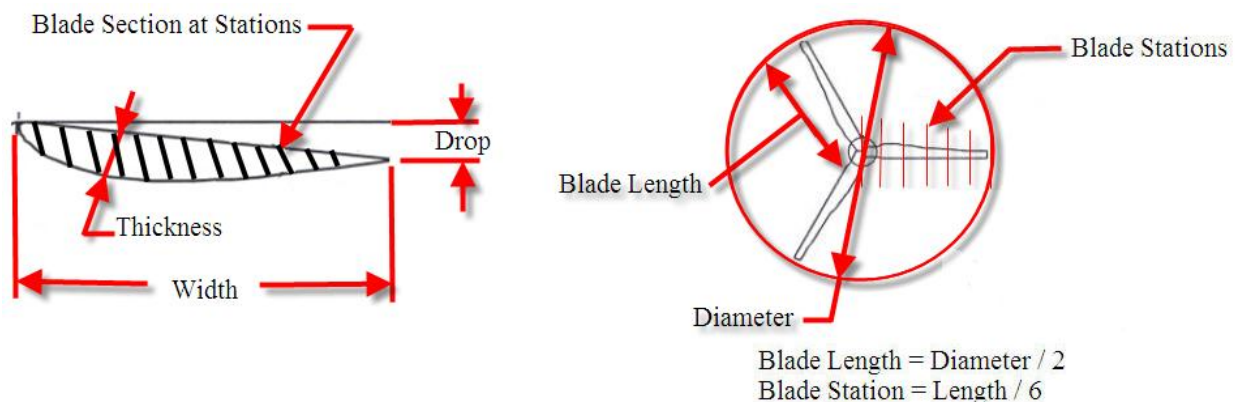

Figure 1. Hugh Piggott Blade Design Parameters (Piggott, 2005).

The Hugh Piggott blade design calls for a specific blade shape that changes in size and angle from the tip to the root defined at six stations. For the four foot blade design, these stations are spaced eight inches apart. Each station has a specific width, drop and thickness. The blades can be carved using hand tools, but the senior design team opted to utilize NX CAM software to generate a tool path which was post processed to M & G code for a Haas VF3 machining center. Using a 3/8 inch diameter ball end mill

the program created three identical blades that had the exact geometry necessary for the proper wing lift.

The VAWT Darrieus and Savonius Designs

There are two different types of blade designs for VAWTs; one is the Savonius model that resembles an anemometer which has three cups rotating on a shaft; and the other is the Darrieus model that resembles an egg beater with blades that have a flat side and a curved side to create lift. The air passing over the airfoils (wind turbine blades) is converted into rotational momentum which spins the generator similar to the HAWT models, but the difference is that the HAWT blade swept area always faces the wind using a furling tail similar to the way a weather vane works. The VAWT swept area is a cylinder perpendicular to air flow, but while part of the “swept area” is working the other blade or blades are not at an optimal angle to generate lift. The challenge in a VAWT design is to optimize the shape and angle of the blade to minimize the drag caused by the blades not facing into the wind (Rogers, 2008).

A turbine blade designer, Ed Lenz, (2005) using a combination of Savonius design along with the venturi theory came up with a design that is similar to the Darrieus, but with wings similar to the Savonius, and a triangular drum in the middle to guide the flow of air (see Figure 2). The “Lenz Wings” are simply constructed using plywood and aluminum flashing to form the airfoil blades. Lenz credits all those before him for their unique and innovative work in this field, and especially Hugh Piggott for helping him with the formulas for working out the wing angles based on the Darrieus type of blade design (Lenz, 2005).

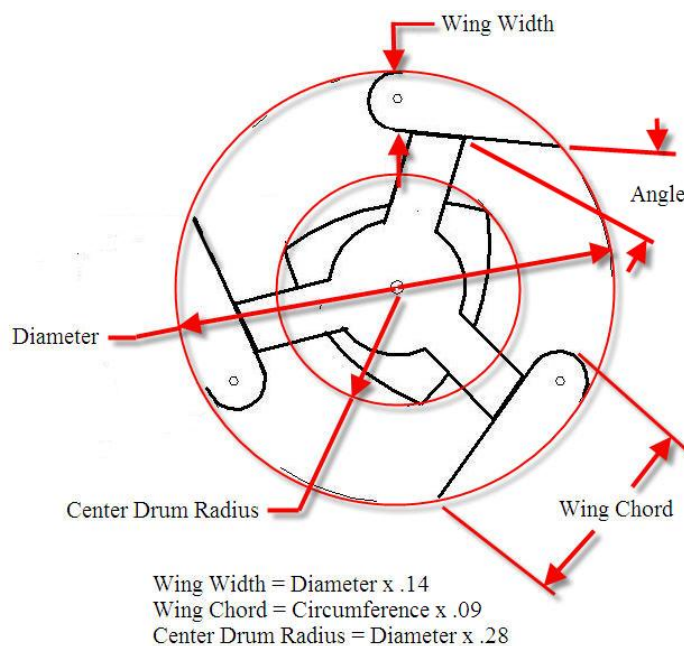

Figure 2. Lenz Wing Design Parameters (Lenz, 2005).

Later the Lenz2 Wing design (see Figure 3) was introduced without the center drum using a modified wing shape and angle, supported on the top and bottom with bearings. This unit measures three feet in diameter by four feet tall and produces a reported 52 watts of power in a 12.5 mph wind with a 12 pole three phase alternator. This is the basis to the VAWT design used by the Michigan Tech MET spring 2009 undergraduate senior project team with an innovative blade mounting system and alternator arrangement (Lenz, 2005).



Figure 3. Lenz2 Wing Design (Lenz, 2005).

CAD Modeling Course Scaffolding Techniques

Prior to taking on a senior project the students would have successfully completed a three course sequence using the NX CAD modeling software. The first course in the sequence, “Technology Computer Applications” is a three credit introductory freshman level course intended to develop knowledge of computer applications such as solid modeling, spreadsheet, word processing, presentation, and project time line software utilized throughout the technology curriculum. Students are required to prepare NX solid models, drawings and assemblies, but the use of expressions for part parameters is not emphasized in this course. An example of a project that students would complete in this course is the modeling and assembly of the Machinist Clamp shown in Figure 4. Later in the curriculum the Machinist Clamp is produced in a “Machine Tool Fundamentals and Applications” course.

The second course in the sequence is “Practical Applications in Parametric Modeling” which is a sophomore level intermediate course intended to expand the student's knowledge of computer modeling techniques, introducing advanced assemblies and GD&T concepts. In this course the instructor asks students to think if the Machinist Clamp CAD model created in the previous course would be more useful if it could be made larger or smaller driven by the product requirements such as the required clamping force. This questioning leads into the advanced concepts available to the

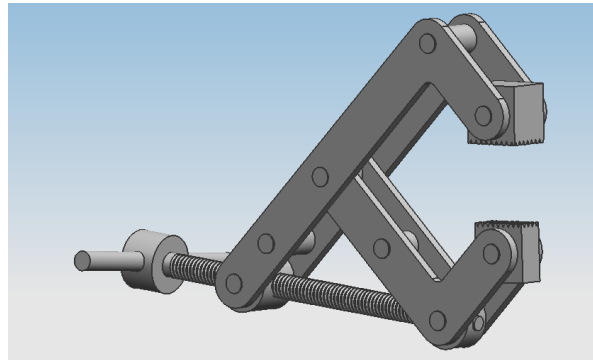

Figure 4. Machinist Clamp.

designer to utilize expressions to drive design intent. An example of modeling using design intent is shown in the laboratory exercise to create the 3D CAD model of the simple I-beam part to satisfy the design intent shown in Figure 5.

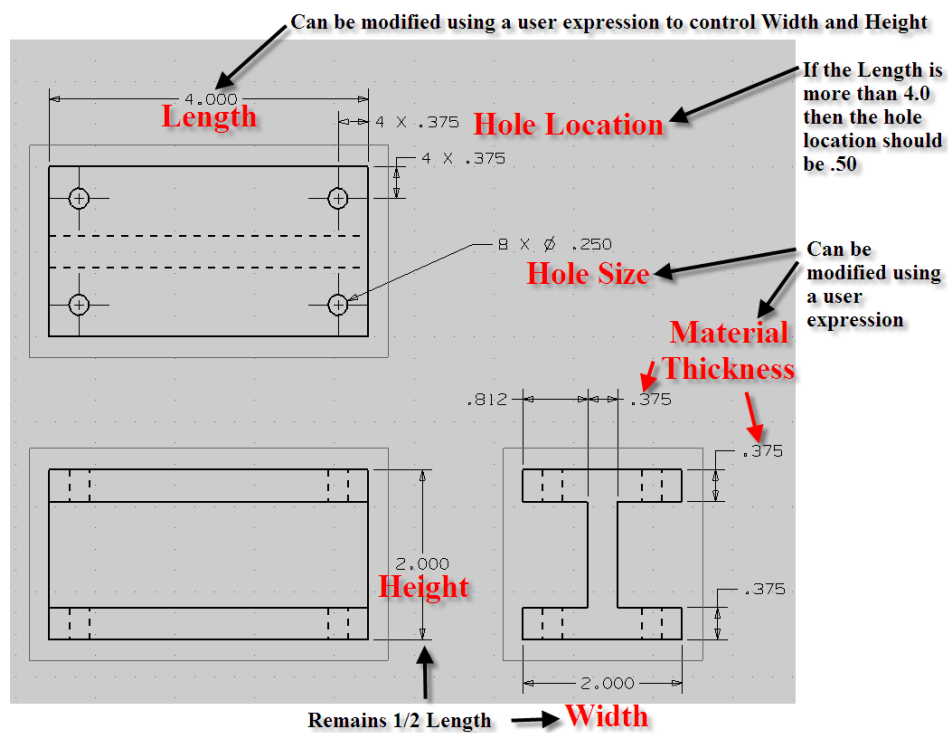

Figure 5. Parametric Model Example.

These design intent constraints on the model are achieved through creating user expressions and then assigning those expressions to design parameters. For instance, the user expression of "Width" is assigned the value of 4.0 and then replaced in the sketch for the constant value. Also, to create relationships to existing expressions the user will insert expressions in the form of formulas to replace constant values. So, the

height parameter in the sketch with the value of 2.0 is replaced with the mathematical relationship of “Width/2” or “Width*0.5” to achieve the design intent. This is accomplished through using the Expressions dialog interface tool shown in Figure 6.

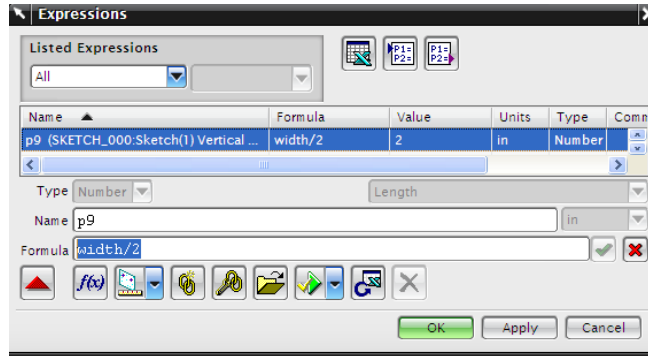

Figure 6. Design Intent Expression Example.

For more complicated relationships such as achieving the hole location design intent for the I-beam, the user would need to use a conditional “if, then, else” statement like the one shown in Figure 7. By accessing the “User Expressions” branch in the part navigator offers more flexibility to the designer to make changes to the model and check out “what if” scenarios for the design. Figure 8 shows that the parameters for user expressions can be edited without having to open the expressions dialog box.

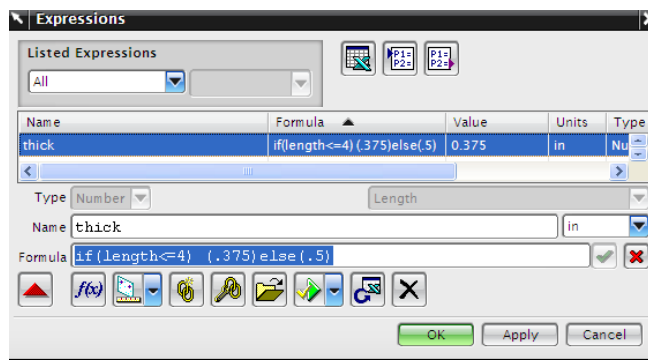

Figure 7. Conditional Expression Example.

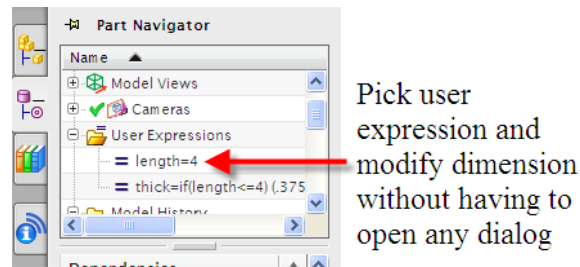

Figure 8. Part Navigator User Expressions.

In the case of creating parametric assemblies the individual component parts must be placed using assembly constraints to satisfy design intent, but also may need either interpart reference expressions or interpart geometry references to link one part's expressions to another part's expression in the assembly. Consider the assembly design intent required in the example shown in Figure 9.

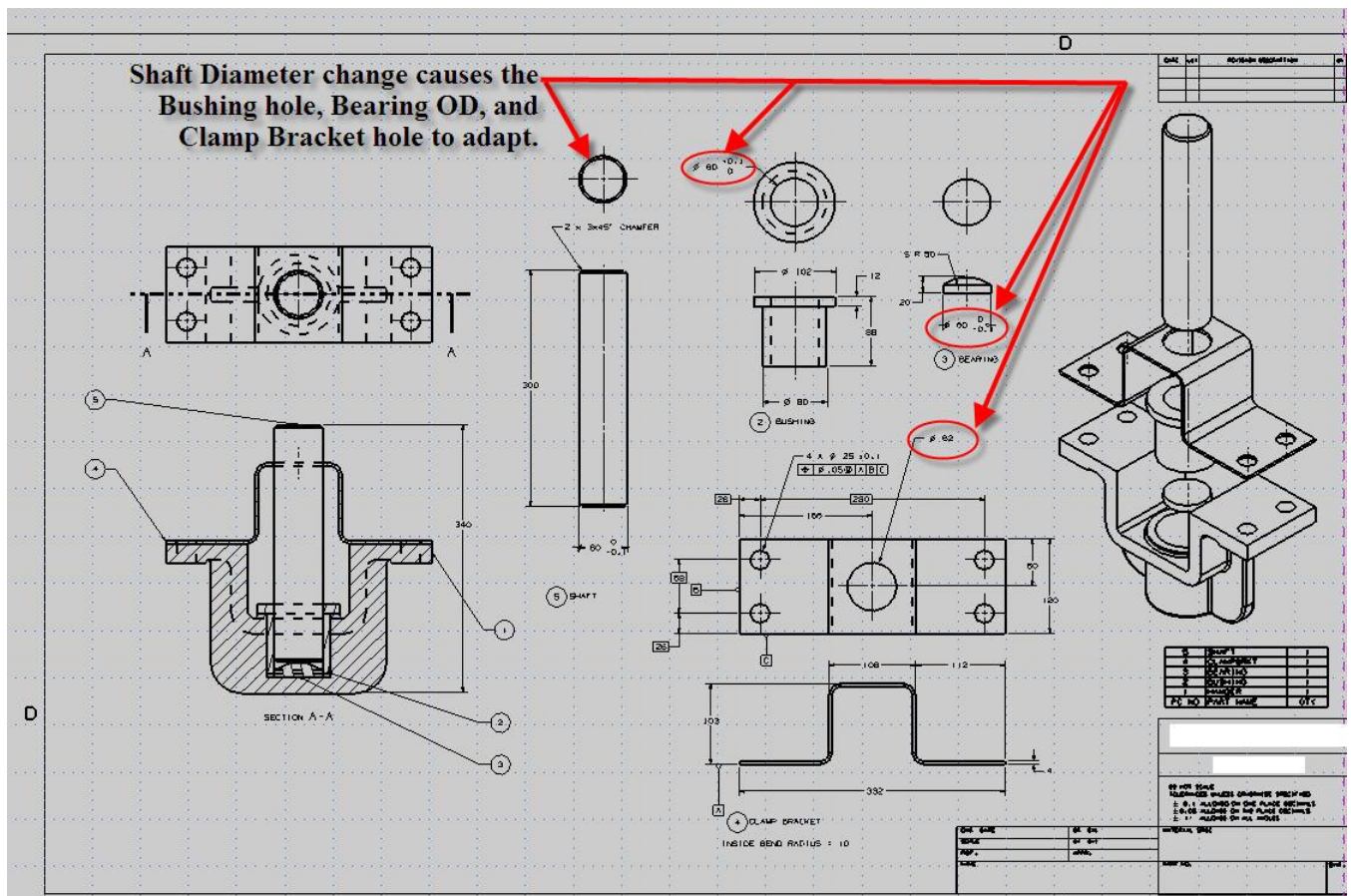

Figure 9. Parametric Assembly Example.

These design intent constraints on the assembly are achieved in a similar manner using the Expressions dialog box interface tool, but to relate part parameters at the assembly level interpart references are used to relate the expression in one part to an expression in another part. The interpart expression can be input at the assembly level or at the component level. In the example shown in Figure 10 the parameter P6 is the expression for the 60mm diameter in the Shaft part model. The parameter P80 is the hole in the Clamp Bracket resulting in a 62mm diameter clearance hole for the Shaft part.

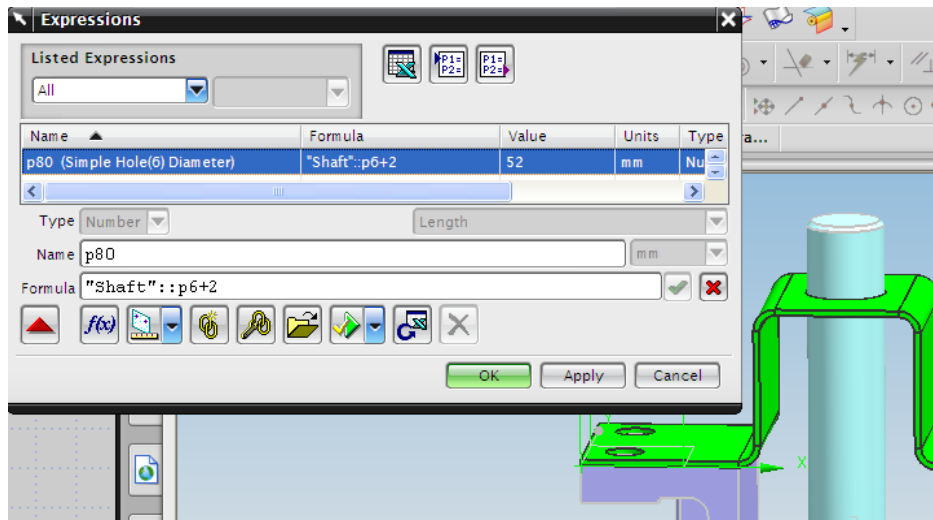

Figure 10. Assembly Design Intent Example.

The final course in the CAD modeling sequence is “Product Design and Development” which is a three credit course covering issues such as design for manufacturing, prototyping, industrial design, and customer needs. The students work in groups assigned to senior projects while utilizing integrated methodologies that examine marketing, manufacturing, concurrent engineering, and complete design projects utilizing CAD systems. In this course the CAD models of the HAWT and VAWT wind turbine blades are introduced to students at the embodiment design stage where they are developing CAD models from their conceptual design sketches. Typically, the CAD models for this course are created using the NX software because of the prior two courses that primarily use NX software. The scaffolding technique is used in this course exclusively to motivate students to use the capabilities and advantages of creating a parametric assembly for a design. In a single class lecture/demonstration the following two examples are presented to illustrate the principle of formula driven expressions for engineering design.

HAWT CAD Model

The complete assembly model shown in Figure 11 contains three instances of the blade model that has the parametric capability to be controlled with a user expression related to either wind speed or Power requirement.

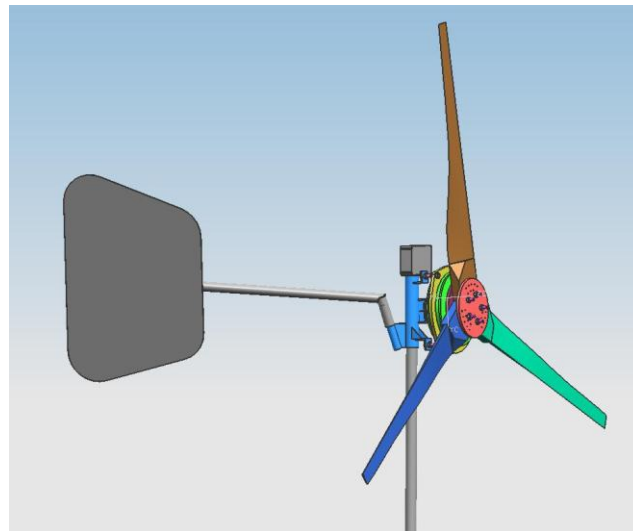

Figure 11. HAWT Complete Assembly Model.

Figure 12 shows the blade model parameter named “Stations” that is related to the expression for the distance between the stations of the wind turbine blade. For a single blade there are six stations located from the root of the blade that attaches to the hub to the tip. For example, in a four foot long blade each station is 8 inches apart, so the formula for the user expression “Stations” is “Bladelength/6”. The user expression “Stations” is used to assign the offset distance between the datum planes in the model of the blade as shown in Figure 13.

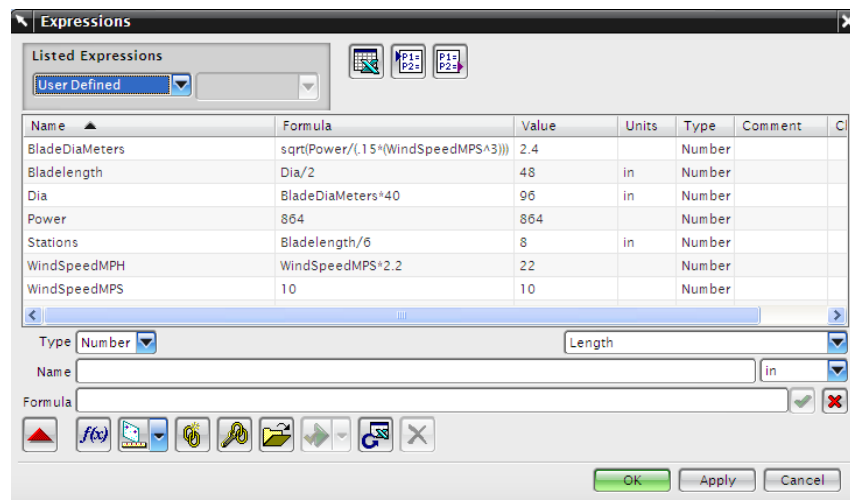

Figure 12. HAWT User Expressions.

To relate this parameter back to the formula used for wind speed and power of a wind turbine the blade length needs to be expressed as a blade diameter. So, next the user expression “Bladelength” is defined as “Dia/2”. The parameter “Dia” is defined as

“BladeDiaMeters*40” the approximate conversion of an inch to meter measurement, since Power is more simply calculated using metric units.

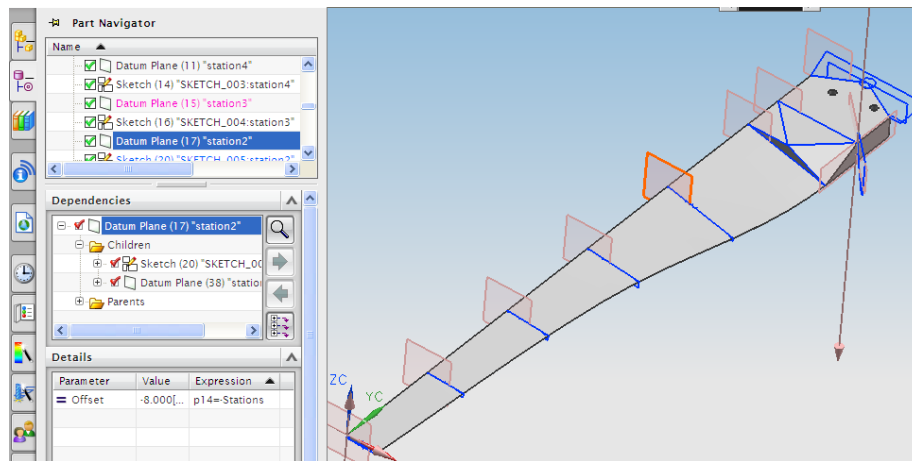

Figure 13. Datum Offset Assigned User Expression Stations.

HAWT Power and Wind Speed Equations

The equation for power provided by Hugh Piggott (2005) for the HAWT blade design is shown in Equation 1.

$$P = EA v^3 \tag{1}$$

where

- P = power (W)
- A = swept area (m^2)
- v = wind speed (m/s)
- E = air density efficiency factor (kg/m^3).

While the swept area (A) is equal to $\pi \times \text{diameter}^2/4$ it has been simplified to just diameter^2 .

The value for air density efficiency factor (E) is calculated as 0.15 as shown in Equation 2.

$$E = \frac{\rho e}{2} \tag{2}$$

where

- ρ = air density (1.2 kg/m^3)
- e = homebuilt blade efficiency (25%) .

So, the expression for “BladeDiaMeters” in Figure 12 is assigned the formula in Equation 3.

$$\text{BladeDiaMeters} = \text{sqrt}(\text{Power}/(0.15*(\text{WindSpeedMPS}^3))) \quad (3)$$

Now the user expressions for “Power” and “WindSpeedMPS” can be manipulated in the CAD model to illustrate what diameter blades are necessary to produce the given result. For instance, the wind speed of 10 MPS and 864 Watts of Power result in a HAWT Blade Diameter of 48 inches. When the user decreases the parameter of Wind speed to 9 MPS, (leaving the Power requirement the same) the blade diameter changes to 56.2 inches. The blade model automatically conforms to the new length, because the Stations parameter changes to 56.2/6 or 9.4 inches. If the wind measurements in an area and the Power requirement desired are known quantities, the designer can optimize the length of the blade for the given situation.

VAWT CAD Model

The complete assembly model shown in Figure 14 contains three instances of the Lenz2 blade model that also has the parametric capability to be controlled with a user expression related to either wind speed or power requirement. For this model the User expressions for power and wind speed are assigned in the assembly model.

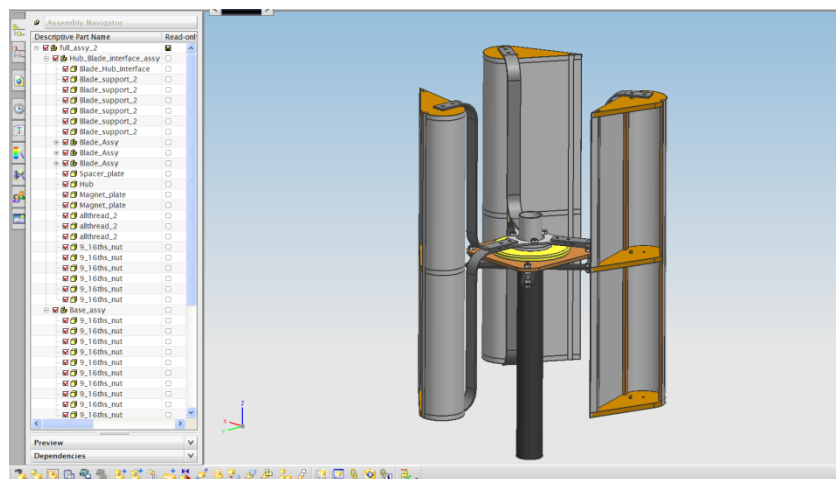

Figure 14. VAWT Complete Assembly Model.

Figure 15 shows the formulas all in units of inches to show that it is not necessary to convert all measurements to metric units. For this example the following Equation 4 is used.

$$P = 0.00508Av^3E \quad (4)$$

where

P = power (W)

A = cross-sectional area of the turbine (diameter x height) (ft^2)

v = wind speed (MPH)

E = efficiency factor.

While the efficiency factor (E) for this blade design is calculated as 31% by multiplying the alternator efficiency of 75% by the blade efficiency of 41%.

Example: the 3' diameter x 4' high blades as shown in Figure 14 subjected to a 15 MPH wind would have a power output of:

$$0.00508 * 12 * 15^3 * .31 = 63.26 \text{ watts}$$

So, using the expressions shown in Figure 15 the “BladeArea” is assigned the formula in Equation 5.

$$\text{Watts}/(0.00508*(\text{MPHWind}^3)*\text{AltEff}*\text{BladeEff}) \quad (5)$$



Figure 15. VAWT Assembly User Expressions.

The expression “asmdia” in the model refers to the distance across the VAWT when looking at a Top view as shown in Figure 16. So, to relate this to the “BladeArea” it is assigned the formula in Equation 6.

$$(\text{BladeArea}/4)*12 \quad (6)$$

Where the value of “4” is the height of the blades, which in this example cannot be modified, and the value of “12” is to convert feet to inches. Now, the “asmdia” expression is used at the component level to vary the lengths of the Blade Support part to meet the required assembly diameter.

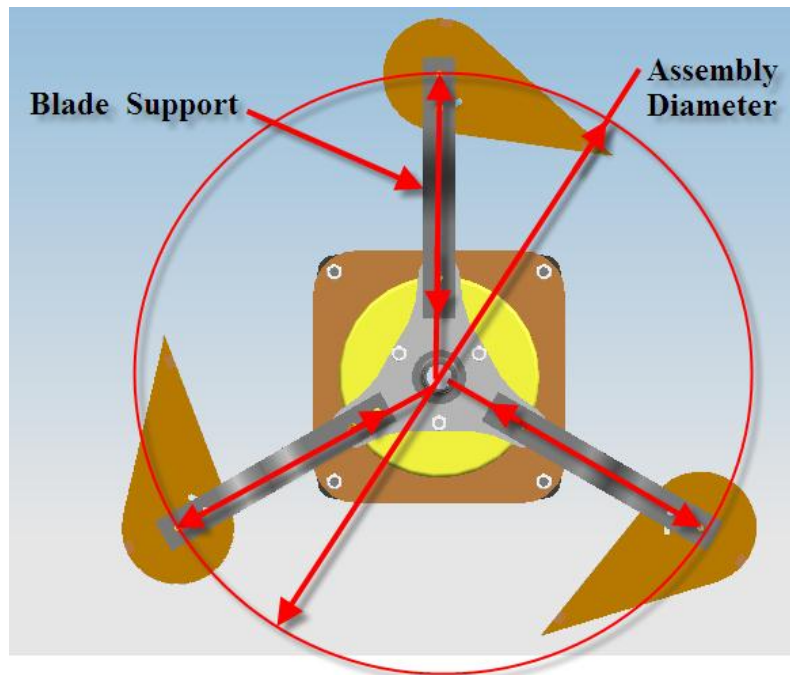

Figure 16. VAWT Top View Showing "asmdia" Dimension.

Also, the component part of the VAWT for the blade itself is controlled by expressions that relate to the "asmdia" expression. As designed by Lenz (2005) the formulas shown in Figure 17 apply to the shape of each Wing of the VAWT.

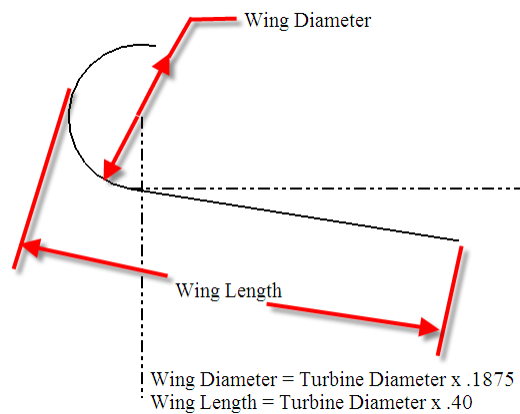

Figure 17. Lenz Blade Design Parameters (Lenz, 2005).

So, in the component model of the Blade part the "Dia" expression is assigned the interpart reference in Equation 7.

"full_assy_2"::asmdia

(7)

Now, when the “asmdia” variable changes due to the designer needs to try out different power requirements and wind speeds the Blade Support parts change length modifying the assembly diameter and the blades themselves change size to adhere to the Lenz design that dictates that the wing diameter be 0.1875 times the assembly diameter and the wing length be 0.4 times the assembly diameter as shown in Figure 18.

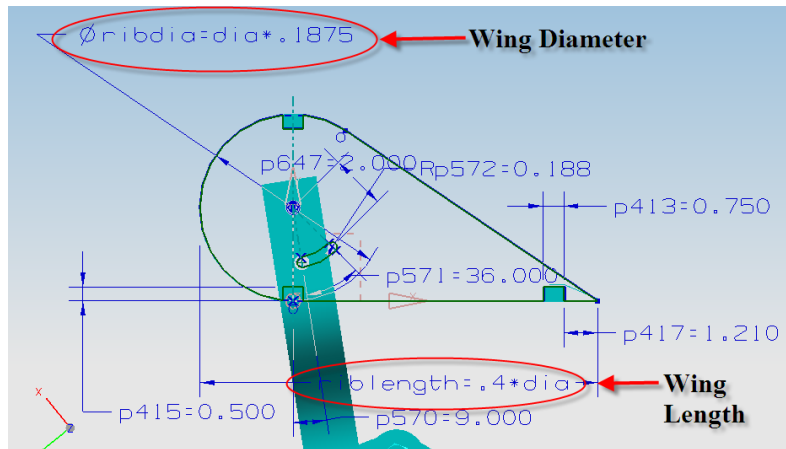

Figure 18. VAWT Blade Sketch Expressions.

For instance, let’s say we want 63 watts of Power in a 15 MPH wind using the Equation 5:

$$\frac{63}{0.00508 * 15^3 * .31} = 11.94 \text{ sq ft (or a 3ft diameter x 4 ft tall blade).}$$

When the user decreases the parameter of Wind speed to 14 MPH leaving the Power requirement the same the assembly diameter changes from 36 to 44 inches and the model automatically conforms to the length because the support parts lengths change as well as the blade wing diameters. Results of this “what if” scenario are shown in Figure 19.

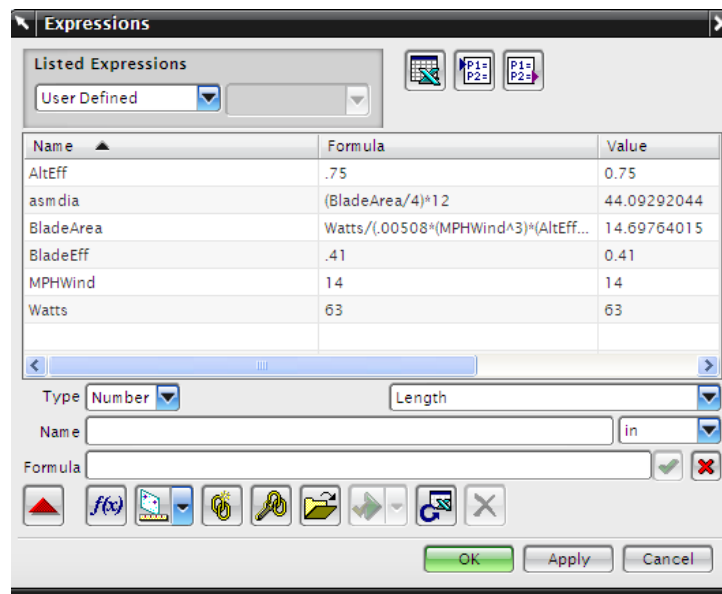

Figure 19. VAWT “what if” Scenario.

Results

In the semesters following the implementation of utilizing the Wind Turbine Project as a scaffolding technique several senior project groups have developed parametric assemblies using expressions to help design their projects. Shown in Figure 20, a senior project group in 2011 developed an aluminum tube constructed frame design for a hovercraft based on formulas that determined the area necessary for the required lift. The group created component parts based on the parameters of “crftwidth” and “crftlength” so that as the overall weight of the craft increased with added components the area could be modified.

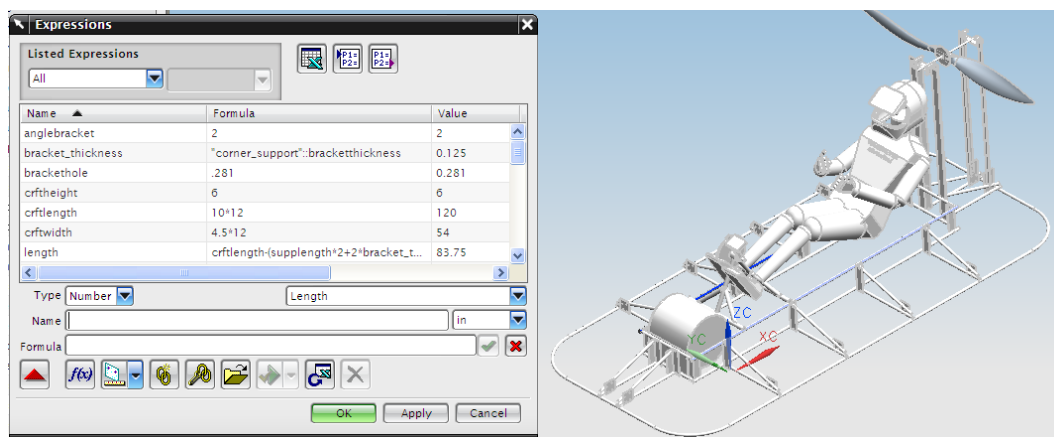

Figure 20. 2011 Hovercraft Senior Project.

A 2012 project that was inspired by the Wind Turbine models was a fairly simple design of an energy storage system to house the batteries and electronics for the wind turbine, but it was necessary to make modifications as the design progressed. The number of batteries had not been determined early on in the design process, so the model was created so that its volume could be modified as the size and number of batteries needed was determined. The model is shown in Figure 21 with the user expressions for “box_height”, “box_length”, and “box_width” which were created to change the size of the compartment if more energy storage was needed.

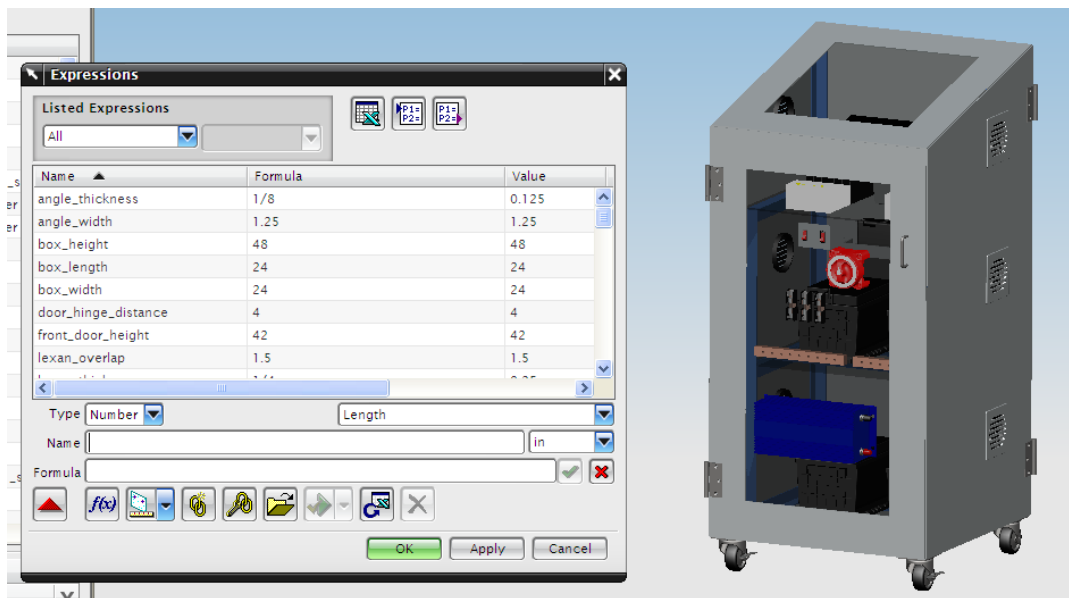

Figure 21. 2012 Energy Storage System Senior Project.

Conclusion

Computer-aided design has become more than creating a 3D CAD model for the sole purpose of generating a 2D graphic representation of a part for manufacturing. The idea of utilizing expressions in the 3D model and assembly for engineering design purposes expands the possibilities for the designer to try out several scenarios in the model before going into production. Illustrating this capability with a real-world project like the Wind Turbine CAD models has motivated students to see that it is something that they can accomplish themselves.

To accomplish this level of parametric capability there is an additional amount of training and effort required to add the expressions into the models while adhering to sound assembly constraint rules and modeling procedures depending on the design intent. Given the extra capabilities of the model to conform to the design requirements it is well worth the extra time spent.

References

- Dewey, John. (1938). *Experience and Education*. New York: Macmillan.
- Irwin, J. L. (2009). Horizontal vs. Vertical Axial Flux Wind Turbine Design and Manufacture, *Proceedings of the Association of Technology, Management, and Applied Engineering 2009 Conference*. (pp.1-9) Louisville, Kentucky.
- Irwin, J. L. (2011). Utilizing Expressions for Developing Parametric Wind Turbine Blade Models, *Proceedings of the Americas User Conference 2011 Siemens PLM Connection*, Las Vegas, Nevada.
- Lenz, E. (2005). Lenz2 Turbine. Retrieved January 27, 2009, from http://www.windstuffnow.com/main/lenz2_turbine.htm
- Piggott, H. (2005). *How to Build a Wind Turbine*. Scoraig, UK: Scoraig Wind Electric.
- Powell K. & Kalina C. (2009). Cognitive and Social Constructivism: Developing Tools for an Effective Classroom. *Education*, Vol.130, No. 2, pp 141-151. Available at: <http://www.edpsycinteractive.org/articles/2009-powell-kalina-cognitive-and-social-constructivism.pdf>
- Rogers, A. (2008). Wind Power: Are Vertical Axis Turbines Better? Q & A with wind expert Mike Sagrillo. *Mother Earth News*. Retrieved February 4, 2009, from: <http://www.motherearthnews.com/Renewable-Energy/2008-02-01/Wind-Power-Horizontal-and-Vertical-Axis-Wind-Turbines.aspx>
- Samuel, S., Pragada, A., Stevenson, B., and Weeks, E. (2010). Basic to Advanced NX7.5 Modeling, Drafting, and Assemblies: *A Project Oriented Learning Manual*. San Jose, CA: Design Visionaries.

Acknowledgements

This original CAD models for the HAWT were created by Michigan Tech MET senior project students, Paul Audije, Alicia Hemenger and Stephen Spalding, and for the VAWT by, Kyle Peters, Tyler Bair and Jim Kramer.

About the Author

John Irwin is an associate professor and program chair of mechanical engineering technology in the School of Technology, Michigan Technological University. His areas of expertise include jig, fixture, and gage design; the design and manufacture of environmental simulation chambers and A/C units for locomotives and mass-transit units; and the design and testing of residential axial flux alternator turbine systems. Dr Irwin is also an Adjunct Associate Professor, Cognitive and Learning Sciences.
Email: jlirwin@mtu.edu