

A Low Cost Virtual Reality Human Computer Interface for CAD Model Manipulation

Abhishek Seth, Shana S. Smith, Mack Shelley, Qi Jiang
Iowa State University

Abstract

Interactions with high volume complex three-dimensional data using traditional two-dimensional computer interfaces have, historically, been inefficient and restrictive. However, during the past decade, virtual reality (VR) has presented a new paradigm for human-computer interaction. This paper presents a VR human-computer interface system, which aims at providing a solution to the human-computer interaction problems present in today's computer-aided design (CAD) software applications. A data glove device is used as a 3D interface for CAD model manipulation in a virtual design space. To make the visualization more realistic, real-time active stereo vision is provided using LCD shutter glasses. To determine the ease of use and intuitiveness of the interface, a human subject study was conducted for performing standard CAD manipulation tasks. Analysis results and technical issues are also presented and discussed.

Introduction

Present CAD systems use 2D computer interfaces, e.g. a standard display monitor, keyboard, and mouse, to generate and interact with CAD models. However, the 2D nature of a standard monitor, keyboard, and mouse, tend to restrict interaction with complex 3D models. Creative programming has enhanced the capabilities of 2D interface techniques, to a certain extent, but has never been successful in making user interaction with 3D CAD models naturally intuitive and completely efficient. Using a 2D interface, designers could miss design errors that might be clear in a 3D interface.

Object manipulation problems in today's CAD systems are also well documented (Chu, et al. 1998). For example, most CAD systems only allow a single object manipulation transformation at a time, e.g. either rotation about an axis or translation along an axis. Thus, to attain a desired model view, a designer must perform a series of transformations. The process is often neither natural nor intuitive, compared to manually manipulating a 3D physical object.

However, recently, VR has provided an unprecedented human-computer interface that is better suited for interacting with 3D models (Perles, 1999). VR empowers users to see and analyze abstract and complicated features

by mapping high-volume, multidimensional data into meaningful stereo displays and by enabling intuitive 3D interactions (Singh, 1996).

Yuan and Sun (1997) used data glove devices to perform mechanical assembly in virtual environments. They used different hand shapes (postures) to generate four discrete control commands for performing assembly tasks. They concluded that the use of an intuitive 3D interaction device in virtual environments requires less user training time and increases work productivity.

Jayaram *et al.* (1999) used a Cyber Glove, Head Mounted Display (HMD), and electro-magnetic tracking devices to create a Virtual Assembly Design Environment (VADE) for addressing mechanical system assembly issues in virtual environments. They used HMD's to generate high-resolution real-time stereo views of an assembly process. Their system facilitated two-way data transfer between Pro/Engineer and a VR environment, and had collision detection, multiple part manipulation, and dynamic simulation capabilities for assembly evaluation.

Prior 3D interface systems required highly specialized and costly equipment. Configuring and using such systems also required a high level of technical skill in VR technology. Most prior approaches stressed building new VR-enabled CAD systems, while only a few focused on

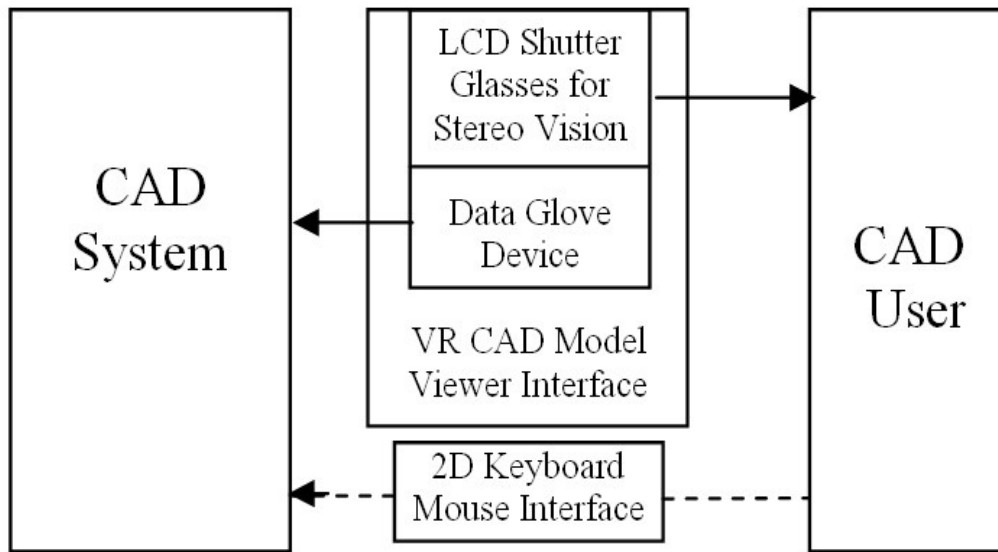

Figure 1 VR CAD Model Viewing Interface

providing VR interfaces for existing commercial CAD systems. As a result, most modern CAD systems, such as Pro/Engineer, AutoDesk Inventor, Solid Works, etc., still use traditional 2D keyboard and mouse interfaces to interact with complex 3D CAD models. Thus, to-date, the design community has not widely accepted using VR interfaces; VR use, so far, has been limited to specialized research applications.

This paper describes a prototype low-cost VR CAD model-viewing interface that can import CAD models created in commercial CAD systems like Pro/Engineer and display the models in stereo views on a standard computer monitor. To make object manipulation more intuitive and efficient, the interface uses a data glove device to allow more natural hand interaction with displayed CAD models. A human subject study was conducted to determine the ease of use and intuitiveness of the interface, and to study users' response to the interface.

Figure 1 shows a schematic diagram of the prototype interface. The schematic diagram shows that the system allows a designer to interact with CAD models, using an inexpensive data glove device, and provides real-time stereo views of a CAD model, to enhance visual realism. Stereo viewing capability provides depth cues, which carry information concerning spatial relationships between the parts in a complex assembly, and,

thus, provides better visual feedback to users than traditional 2D projection techniques.

Vr-cad Viewer

The proposed VR interface consists of two parts: a visualization component and a 3D interaction component. For enhancing visualization, real-time stereo viewing is provided. A computer monitor and a pair of LCD shutter glasses are used to create a virtual world. In order to make the interface more intuitive, CAD model interaction is provided using hand gestures. A data glove device is used for gesture recognition and model manipulation in the virtual environment. The main reason for using a 3D interface is to enable a designer to manipulate CAD models with the same number of degrees of freedom as the environment in which the actual part exists.

Importing CAD models from CAD Systems

The proposed VR CAD model viewer imports CAD models using the Open Inventor (.iv) ASCII file format, which is supported in Pro/Engineer. The entire system is implemented in C++, and a Microsoft foundation class graphical user interface is provided.

Stereo Viewing Method

The proposed system uses the sync-doubling method to display stereo images of CAD models on a computer screen. The sync-doubling method uses two subfields for the left and right frame of

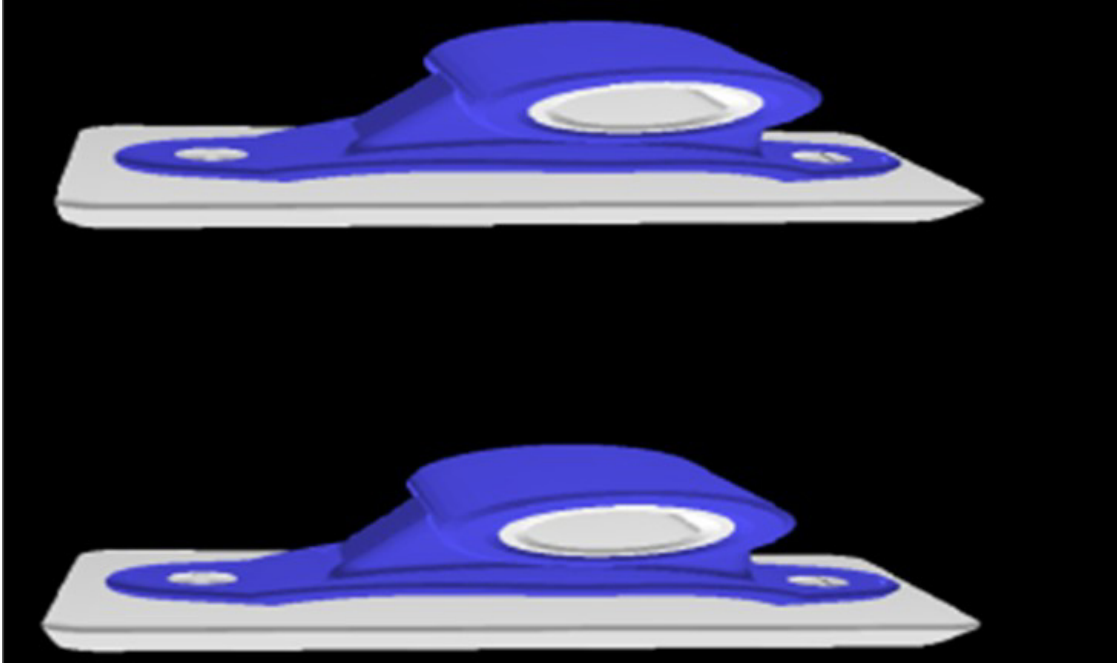

Figure 2 Sync-doubling Method

the image as shown in Figure 2. The images in the upper and lower subfields are squeezed in the vertical direction by a factor of two. An external circuit (a sync doubler) is used, which stretches the left and right eye images to normal size. The sync-doubler increases the refresh rate of the monitor to 120 frames per second, and, thus, the left and right images appear on the screen alternately, every 1/120th second.

For the proposed system, shutter glasses from Eye3D (<http://www.iart3d.com>) are used for stereo viewing. The shutters in the LCD glasses are synchronized with the images on the monitor, with the help of an infrared emitter, which provides a signal to the glasses for triggering the shutters precisely. The resulting stereoscopic views provide depth-cues, which are helpful for understanding the spatial relationships between the different parts of a complicated CAD model.

Data Glove Interface

The data glove used for the proposed system is a 5DT Data Glove from 5DT Corporation (<http://www.5dt.com>). The 5DT Data Glove has 5 sensors for sensing finger flexures. The data glove consists of a lightweight lycra glove with fiber optic sensors embedded along the backs of the fingers. When the user starts moving his or her fingers, finger flexure bends the optical fibers along the fingers. Bending the optical fibers

causes variations in the strengths of signals sent through each of the fibers. The signals are sent to a processor that uses signal strengths to determine the joint angles of each finger. In addition to optical fibers for measuring finger flexure, the 5DT data glove also has a tilt sensor for measuring the orientation of the hand by reading tilt sensor pitch and the roll values.

Gesture Recognition and Mapping

For each gesture, a finger flexure value for each finger is predefined. After the glove is connected, object manipulation controls are transferred to the glove. The 3D object can then be manipulated by using the glove, rather than a mouse. To recognize a gesture, the angular flexure values from each finger joint are collected. The angular flexure values are then converted to angular values representing hand and finger movements of the user.

A complete gesture value consists of predefined angular flexure values for all five fingers. If the collected flexure values for each finger lie within predefined ranges, then a particular gesture is recognized by the system. A number of prior research studies have been conducted related to gesture recognition using various types of gloves (Lee et al, 2000; Takahashi and Kishino, 1992; Trika et al., 1997). To keep the system simple, based upon prior research, hand movements are

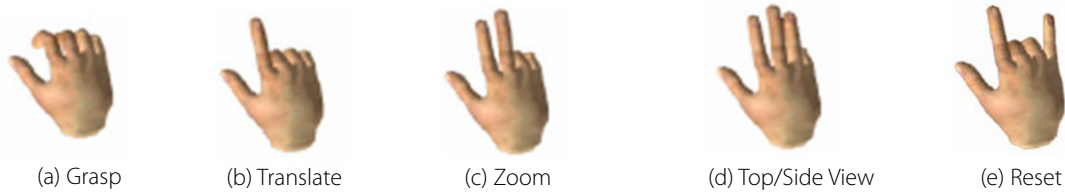

Figure 3 Hand gestures

not considered to be part of a gesture, and only static gestures are recognized by the system.

The VR CAD model viewer uses the glove interface to perform fundamental navigation tasks, such as zoom-in, zoom-out, viewpoint translate, rotate, and reset. Some views such as top-view and side-view, which designers frequently require, are also mapped to different gestures, to facilitate orienting the model directly without going through intermediate transformations.

To perform a navigation task, the user needs to make the assigned gestures, as shown in Figure 3. When a gesture is recognized by the system, the user can manipulate the CAD model by changing their hand orientation. For example, to rotate the object along any arbitrary axis, the user must grasp the model and then vary the pitch and roll values of the tilt sensor. The index and middle finger point gesture, as shown in Figure 3(c), initiates zoom mode. After gesture recognition, the tilt sensor's roll value controls zooming in and out. A flat hand gesture releases the object. Object translation is controlled by an index finger point gesture, as shown in Figure 3(b). The tilt sensor's roll, and pitch values make the object translate. The gesture shown in Figure 3(d), combined with roll values, controls toggling between model top and side views. The index and little finger point gesture shown in Figure 3(e) resets the model to its original start position. According to prior research (d'Ydewalle et al. 1995), it has been shown that experienced users work more efficiently with word processors when using keyboard shortcuts than with the mouse. We generalized d'Ydewalle et al's observation to 3D tasks by using hand gestures in the form of a simple sign language to perform 3D interaction tasks.

Experiment

An experiment was performed to evaluate the VR CAD model-viewing application interface. Sixteen subjects participated in the study. All sub-

jects had previous experience performing CAD model manipulations using commercial CAD software applications. The subjects were asked to perform a set of object manipulation tasks using the data glove interface and the same tasks using a traditional keyboard and mouse interface. While interacting with the keyboard and mouse interface, the participants could rotate the model by pressing the left mouse button. Translate and zoom transformations could be performed by using the left mouse button in conjunction with the "ctrl" or "shift" key, respectively. The time required for performing each task was carefully measured.

The same CAD model assembly was used for performing the assigned tasks with both the keyboard-mouse and data-glove user interfaces. Before performing the specific experiment tasks, all users were given a demonstration showing how to use the data glove, and they were given some time to become familiar with the interface.

The task given to the study subjects was to manipulate the CAD model so that it appeared on the computer screen in four different required orientations. Figure 4 shows the four final required object orientations. Specific gestures were assigned to achieve the side view (Task 2) and top view (Task 3). However, to achieve the bottom view (Task 1) and an arbitrary position of the side view (Task 4), the users had to develop a set of object transformations themselves. After each task, users had to reset the model and bring it back to the initial orientation. All the subjects were carefully observed during the experiment. After the tests, the subjects were asked to fill out a questionnaire providing their opinions concerning the new interface for CAD model viewing.

Results

After completing all four study tasks, a survey was conducted. Questions 1-5 were multiple choice questions to elicit spontaneous responses from the subjects. Distributions of responses for

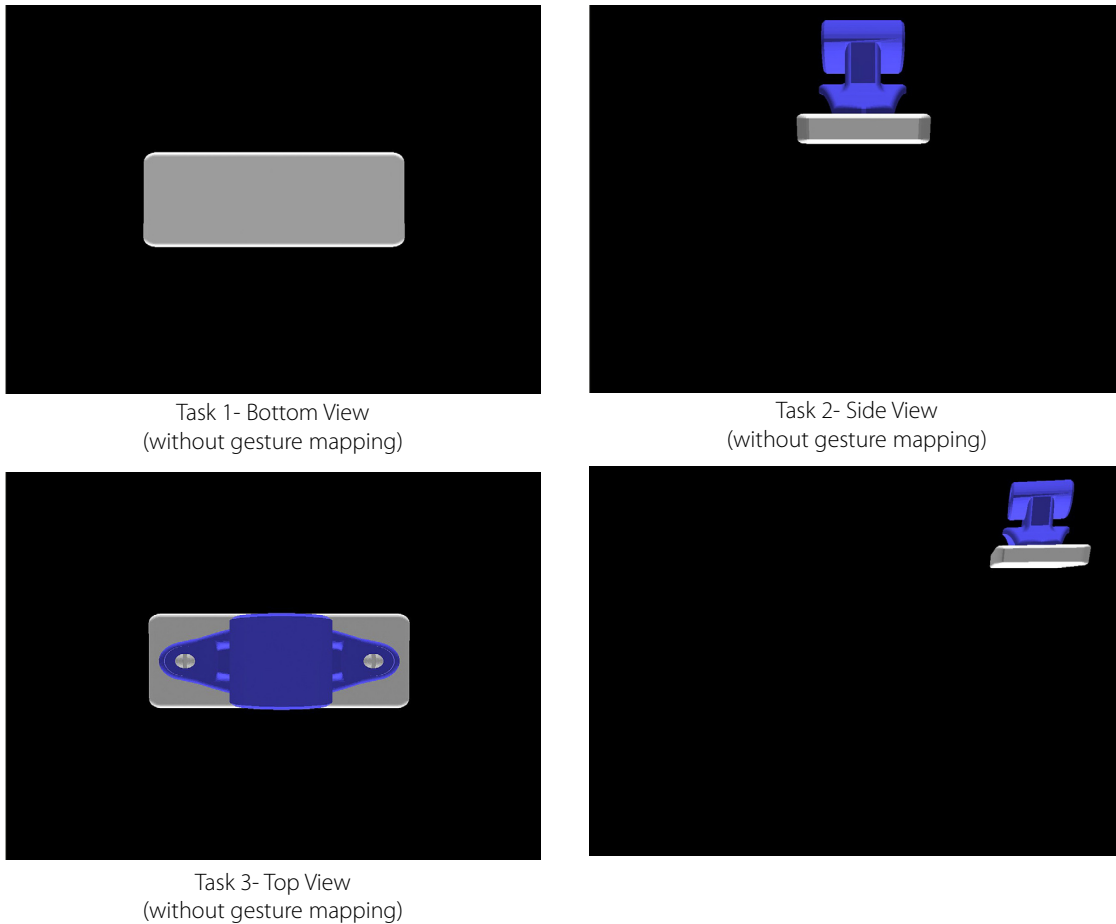

Figure 4 Model Arrangement Tasks

the multiple choice questions are provided in the histograms shown in Figure 5.

From the responses to Question 1, it is clear that none of the subjects found the Data Glove device to be non-intuitive. Among respondents, 18.75% of subjects think the data glove interface is very intuitive, 37.5% of subjects think the data glove interface is intuitive, and 43.75% of subjects think that data glove interfaces are ok, with respect to intuitiveness. In addition, the 86% tolerance interval for the mean of response value is (1, 3.5), which shows that there is an 86% chance that the next user will fall within the range. Thus it can be concluded that most of the subjects found the device to be intuitive, while handling CAD models. Responses to the second question indicate that 50% of the subjects prefer the use of the data glove device over a mouse and keyboard, while interacting with CAD models.

A histogram for the third question indicates that all of the users except one found use of glove

device to be easy. Most of users (75%) found the data glove device easy or very easy to use. The 80% tolerance interval for the mean of response value is (1, 3.24), which shows that there is an 80% chance that the next user will fall within the range. Responses to the fourth question indicate that 56.3% (i.e., 9 subjects) of the subjects reported that none of the gestures were unnatural, while 43.8% (i.e., 7 subjects) reported that some of the gestures were unnatural for object manipulation. From the responses for question five, 93.8% (i.e., 15) of the subjects reported that the VR interface will be useful as an introductory tool in an undergraduate design class.

From the results shown in Table 1 and Table 2, the mean time consumed performing Task 1 and Task 4 using the glove device is greater than the mean time taken for performing the same tasks with the keyboard and mouse interface. This conclusion is supported by the results of a repeated measures analysis of variance comparing mean

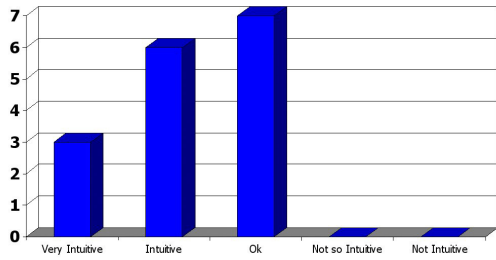

Q1 In your opinion, how intuitive is the data glove interface, for manipulating CAD models?

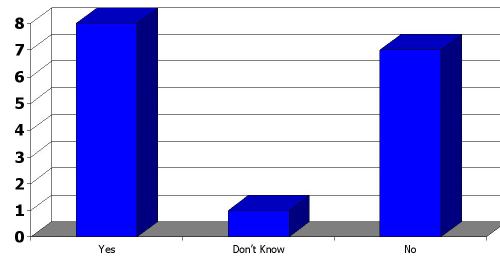

Q2 Do you prefer this interface over a conventional mouse and keyboard?

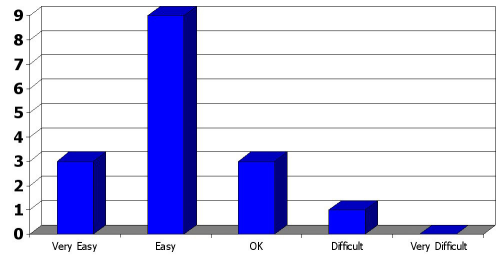

Q3 How easy do you think this interface is to use?

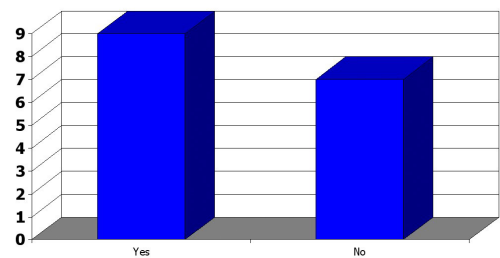

Q4 Do you think any gestures you used for manipulation were unnatural?

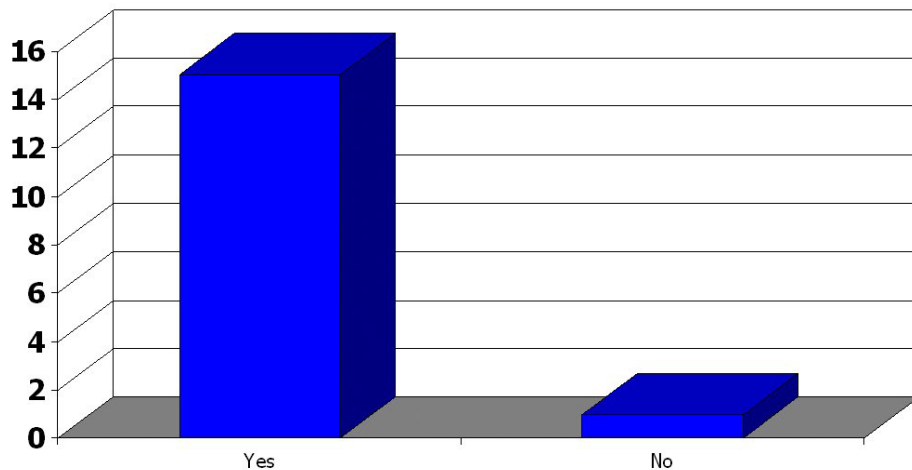

Q5 Do you think this interface will be useful as an introductory VR tool for undergraduate students taking an engineering design class?

Figure 5 Histograms showing responses to questions

completion times for each task between the glove and the mouse and keyboard interface. A t test was used to check whether there is a significant time difference between using the data glove and the mouse and keyboard interfaces for Task 1 and Task 4. Time required for Task 1 completion is significantly higher ($t = -2.13316$ with $df=15$, p value is 0.024) for the data glove interface (Mean value = 4.326) than for the mouse and keyboard interface (Mean value = 2.842). Use of the glove versus the mouse and keyboard accounts for 34.3% of the

variation in performance from subject to subject on Task 1. For Task 4, a significantly greater time to completion ($t = -3.902$ with $df=15$, p value is 0.0007) was also found for the data glove (Mean value = 17.529) than for the mouse and keyboard interface (Mean value = 7.435). For Task 4, the use of a glove versus mouse and keyboard accounts for 57.3% of subject-to-subject variation in performance. One possible reason for the result is that all users who took part in the study were familiar with commercial CAD tools and,

One-Sample Statistics				
	N	Mean	Std. Dev	Std. Error Mean
TASK 1	16	2.8419	1.25332	.31333
TASK 2	16	2.6687	.99744	.24936
TASK 3	16	2.7006	1.13783	.28446
TASK 4	16	7.4350	3.38540	.84635

Table 1 Mean time values for tasks using the mouse and keyboard interface

One-Sample Statistics				
	N	Mean	Std. Dev	Std. Error Mean
TASK 1	16	4.3256	2.48388	.62097
TASK 2	16	2.2613	1.67430	.41858
TASK 3	16	2.3100	1.68498	.42125
TASK 4	16	17.5294	9.77767	2.44442

Table 2 Mean time values for tasks using the glove interface

thus, more adept at interacting with models using the conventional mouse and keyboard interface. Working with the methodology and behavior of the data glove device were completely new to all of them.

In contrast, the mean times for performing Task 2 and Task 3 using the data glove interface were less than the mean times for performing Task 2 and Task 3 with the mouse and keyboard interface. The results for Task 2 and Task 3 suggest that the data glove provides a faster interface when the tasks are assigned directly to gestures.

Although there are measurable differences between task times for the glove device and the mouse and keyboard interface, a repeated measures analysis of variance shows that there are no significant differences in time to completion between glove ($M = 2.261$) and mouse and keyboard ($M = 2.669$) for Task 2, or for Task 3 ($M = 2.310$ for glove and $M = 2.701$ for mouse and keyboard).

One interesting observation is that many subjects completed the experiment by accomplishing Task 2 before performing Task 4, which suggests that the subjects liked the directly mapped gestures and tended to make use of those gestures first for performing the required tasks.

These findings should be regarded as preliminary. With a small sample size (16), the results of this study are limited and thus must be interpreted cautiously. However, even with small sample sizes, carefully designed studies with randomly selected observations that are representative of the population (which here is all users of these forms of human-computer interaction technology), can be expected to yield data that provide the foundation for more elaborate follow-up studies, much in

the nature of small-sample medical clinical trials. What we have found here is intended to provide a point of reference for more fully articulated studies to come.

Technical Issues

Subjects complained about a gesture recognition problems with the glove. Even after trying again and again, they were not able to perform certain manipulations. One of the subjects could not reset the part after trying for some time. While performing the reset operation, sometimes the object started to translate. This happened mainly because some subjects found the task of pointing the index and small finger, at the same time, difficult; they could not keep their small fingers straight. Thus, the glove recognized the gesture as only an index finger point, and the object was translated, rather than reset. The reported errors can be eliminated by redefining the finger flexure values, or by using a more natural combination of pointed fingers, for the reset gesture. Another reason for the reported difficulty might be that the glove had only five sensors to sense finger flexures. More sensors might be useful for precise hand gesture recognition and, thus, could help eliminate such gesture recognition problems.

Almost all of the subjects tried to use a “yaw” motion for translating the part right or left, i.e., pointing the index finger was more intuitive for the users than tilting their whole hand to either side, for performing object translation. A glove that senses a yaw motion would be more intuitive and easier to use. Some of the subjects suggested that adding a tracker device would make the interface system better, easier, and more intuitive to use. However, tracker devices are generally high-cost items. Adding a tracker device would increase

the cost of the interface system and, thus, could limit system acceptance for widespread use.

Conclusions

This paper presents a low-cost user-friendly VR-based interface for interacting with CAD models. The interface demonstrated in the paper provides a stereo view of the CAD model for enhanced visualization and enables the designer to interact with the CAD models using a 3D input data glove device with natural hand gestures (grab and release).

Test results indicate that using a data glove to perform specific CAD tasks with direct gesture mappings is very efficient and convenient. However, results also show that using a data glove without direct gesture mapping is slower than using a mouse and keyboard. It was observed that, after using the data glove interface for some time, subjects showed improvement in their performance and started feeling more comfortable with the data glove interface. Most of the subjects found the interface intuitive and easy to use and learn. Almost all the subjects advocated using the data glove device in an undergraduate design class to ensure that future designers are exposed to the application of VR technology in CAD.

References

Chu, C. P., Dani, T. H., & Gadh, R. (1998). Evaluation of virtual reality interface for product shape designs. *IIE Transactions*, 30(7), 629-643.

G. d'Ydewalle et al. (1995), Graphical versus character-based word processor: An analysis of user performance, *Behaviour and Information Technology*, v.14 n.4 p.208-214.

Jayaram, S., Wang, Y., Jayaram, U. Lyons, K., & Hart, P. (1999). Virtual assembly design environment. In *Proceedings of the 1999 IEEE Virtual Reality (pp. 172-179)*. Houston, TX: Institute of Electrical and Electronics Engineers.

Lee, L. K., Kim, S., Choi, Y., & Lee, M. H. (2000). Recognition of hand gesture to human-computer interaction. In *2 Proceedings of the 6th Annual Conference*

of the IEEE Electronics Society (pp. 2117-2122). Nagoya: Institute of Electrical and Electronics Engineers Computer Society

Perles, B. P., & Vance, J. M. (1999). Interactive Virtual Tools for Manipulating NURBS Surfaces in a Virtual Environment. *Industrial Virtual Reality Symposium Proceedings*, Chicago, IL.

Singh, G., Feiner, S. K., & Thalman, D. (1996). Virtual reality software and technology. *Communications of the ACM*, 39(5), 35-36.

Takahashi, T., & Kishino, F. (1992). Hand gesture recognition method and its application. *Systems and Computers in Japan*, 23(3), 38-48.

Trika, S. N., Banerjee, P., & Kashyap, R. L. (1997). Virtual reality interface for feature-based computer-aided design systems. *Computer-Aided Design*, 29(8), 565-574.

Yuan, X., & Sun, H. (1997). Mechanical assembly with data glove devices. In *Proceedings of the Canadian Conference on Electrical and Computer Engineering*. St. John, Canada: Institute of Electrical and Electronics Engineers, 177-180.